

Teileliste und Naehleinrichtungen  
Parts List and Sewing Equipment

**887 - M**

**DÜRKOPP ADLER AG**

Postfach 17 03 51, D-33703 Bielefeld • Potsdamer Str. 190, D-33719 Bielefeld  
Telefon +49 (0) 5 21/ 9 25-00 • Telefax +49 (0) 5 21/ 9 25 24 35 • [www.duerkopp-adler.com](http://www.duerkopp-adler.com)

Ausgabe / Edition: <b>09/2016</b>	Aenderungsindex Rev. index: <b>05.0</b>	Printed in Czech Republic	Teile-Nr./Part.-No.: <b>0791 887801 M</b>
--------------------------------------	--	---------------------------	--

Alle Rechte vorbehalten.  
Eigentum der Dürkopp Adler AG und urheberrechtlich geschützt. Jede, auch auszugsweise  
Wiederverwendung dieser Inhalte ist ohne vorheriges schriftliches Einverständnis der Dürkopp Adler AG  
verboten.

*All rights reserved.*

Property of Dürkopp Adler AG and copyrighted. Reproduction or publication of the content in any manner,  
even in extracts, without prior written permission of Dürkopp Adler AG, is prohibited.

**Copyright © Dürkopp Adler AG - 2016**

## 887 - M

Inhaltsverzeichnis	Tafel / Table	Contents
Armwelle	1	Upper shaft
Antrieb Arm- und Unterwelle, Rastkupplung	2	Upper and bottom shaft drive, Safety clutch
Fadenhebel, Nadelhalter	3	Thread lever, Needle holder
Antrieb Nadeltransport	4	Needle feed drive
Rollfussantrieb	5	Top roller driver
Transportgetriebe	6, 7	Wheel feed drive
Schubwelle	8	Feeding shaft
Transporteursaeule	9, 10	Wheel feed
Fusslueftung Handhebel	11	Top roller lift hand lever
Fusslueftung Kniehebel	12	Top roller lift knee lever
Fusslueftung el.magn.	13	Top roller lift el.magn.
Fusslueftung pneu.	14	Top roller lift pneu.
Grosser Greifer mit Spule	15	Large hook with bobbin
Uebergrosser Greifer mit Spule	16	Oversized hook with bobbin
Greiferlager rechts	17	Hook case right
Greifer links	18	Hook case left
Fadenabschneider	19	Thread trimmer
Kantenschneider	20 - 22	Edge trimmer
Spuler	23	Winder
Spannungsplatte Einnadel mech.	24	Tension plate 1 needle mech.
Spannungsplatte Einnadel el.magn.	25	Tension plate 1 needle el.magn.
Spannungsplatte Einnadel pneu.	26	Tension plate 1 needle pneu.
Spannungsplatte Zweinadel mech.	27	Tension plate 2 needles mech.
Spannungsplatte Zweinadel el.magn.	28	Tension plate 2 needles el.magn.
Stichverstellung 1 Stichlaenge	29	Stitch adjustment 1 stitch length
Stichverstellung 2 Stichlaengen	30	Stitch adjustment 2 stitch lengths
Verriegelung mech., el.magn., pneu.	31	Backtacking mech., el.magn., pneu.
Magnetventileinheit	32	Solenoid valve unit
Verteilerplatte, Taster, Kabel, Abblasesatz	33	Electrical distribution board, Push-buttons, Cable, Blower kit
Zentralschmierung, Oelstandanzeige	34	Central lubrication, Maintenance indicator
Fussandruck konstant	35	Foot pressure constant
Arm, Fadenuefuehrung	36	Arm, Thread guide
Grundplatte	37	Bed plate
Naehleuchte Diode	38	Sewing lamp diode
Antriebspaket fuer Direktantrieb	39 - 42	Motor kit for direct drive
Gestell	43	Stand
Wartungseinheit	44	Maintenance unit
Beipack	45, 46	Accessories

# 887 - M

Inhaltsverzeichnis	Tafel / Table	Contents
USB Memory Stick	47	USB memory key
Teilstich-Einrichtung		Reduced stitch device
Rollenanschlag		Roller stop
Kantenanschlag		Edge guide
Schibradtransporteur gummibeschichtet		Wheel feeder rubberized
Schibradtransporteur - 1,2 mm		Wheel feeder - 1,2 mm
Blocksatz fuer Nadeltransport		Needle feed locking
Variator	48	Variator
Kniehebel	49	Knee lever
Taster		Push-buttons
Einstellung des Rollfusses		Top roller setting
Werkzeug M-Type		Tool kits M-Type
Kantenanschlag		Edge guide
Rollfuss Ø 25	50	Top roller Ø 25
Rollfuss Ø 35	51	Top roller Ø 35
Rollfuss Ø 45	52	Top roller Ø 45
Sicherheits-Features	53	Safety features
Index		Index
Stichplattenschieber		Slide
Naeheinrichtungen		Sewing equipment
Pneu. Geraeteplan		Pneumatic circuit plan

## 887 - M

---



Einnadel-Maschine  
single needle machine



Zweinadel-Maschine  
two needle machine

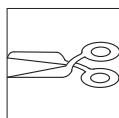

mit Fadenabschneider  
with thread trimmer

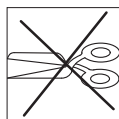

ohne Fadenabschneider  
without thread trimmer

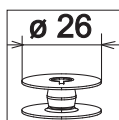

ø 26  
grosser Greifer  
large hook

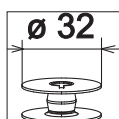

ø 32  
uebergrosser Greifer  
oversized hook

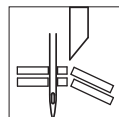

mit Kantenschneider  
with edge trimmer

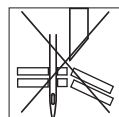

ohne Kantenschneider  
without edge trimmer

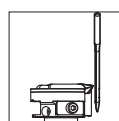

Greifer links der Nadel  
hook left of the needle

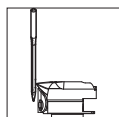

Greifer rechts der Nadel  
hook right of the needle

# 887 - M

---



kleben/stick

N

nicht einzeln lieferbar/not available as separate part

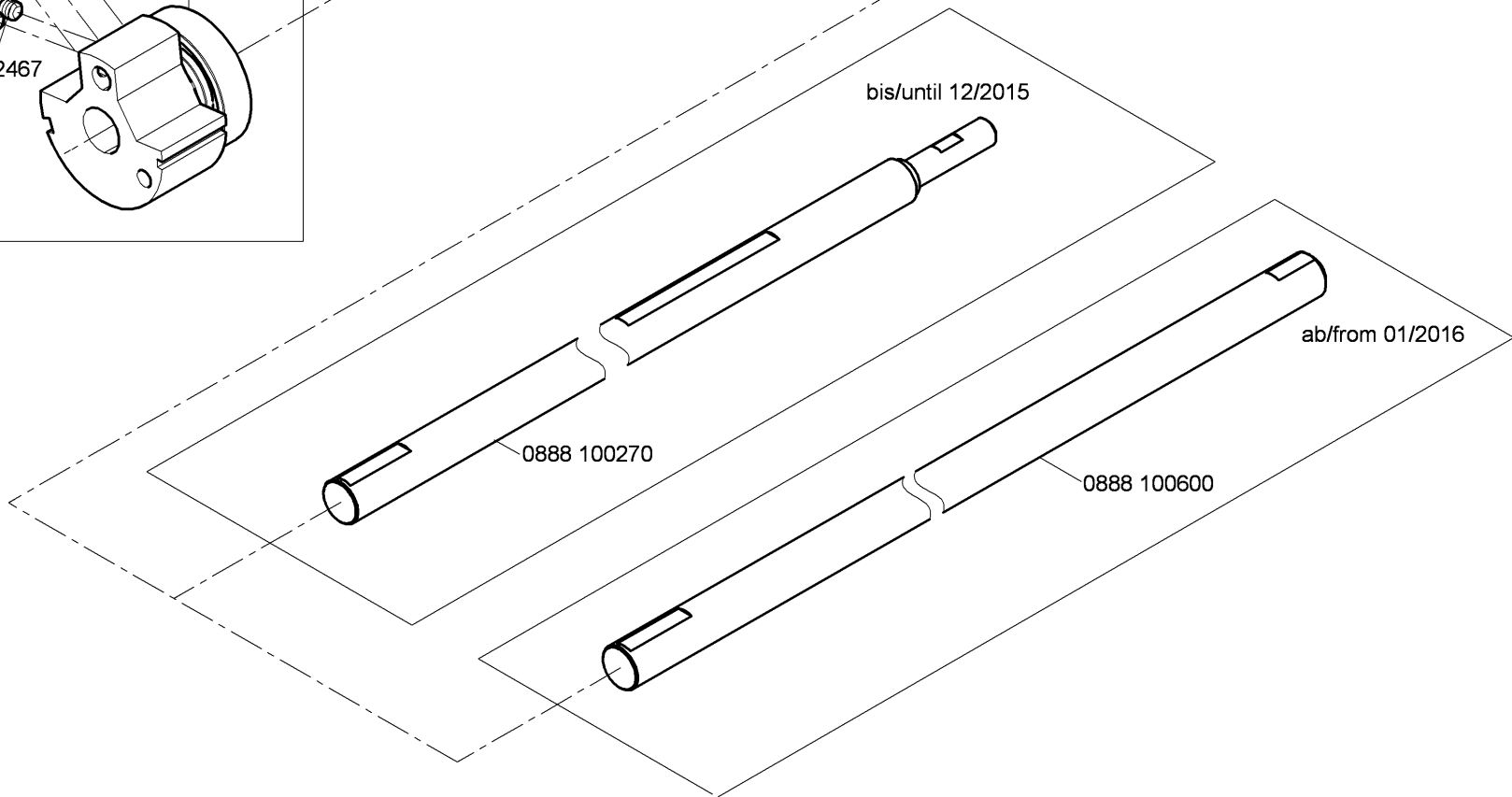
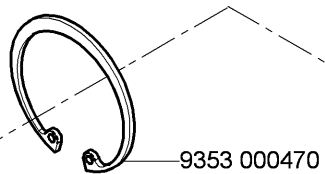
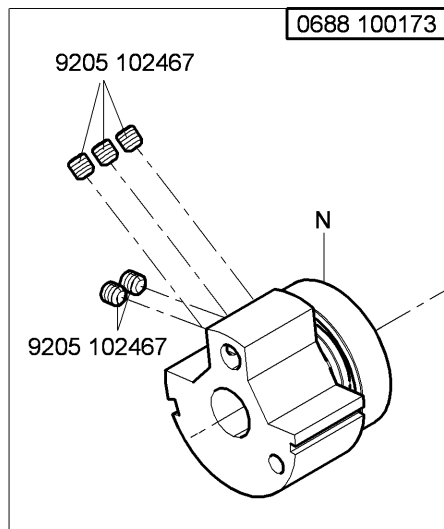

N - nicht als Einzelteil lieferbar  
not available as separate part





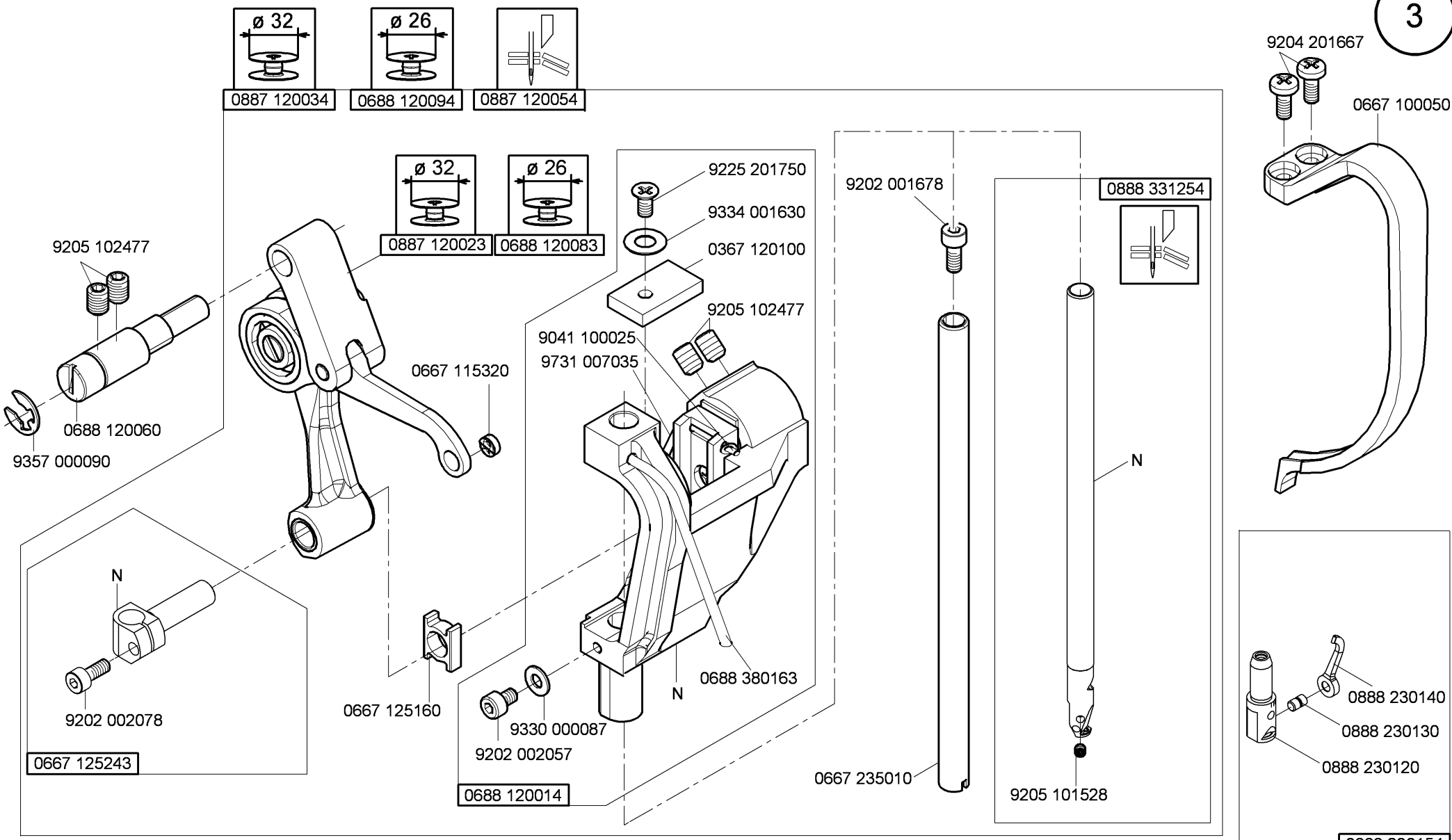

N - nicht als Einzelteil lieferbar  
not available as separate part

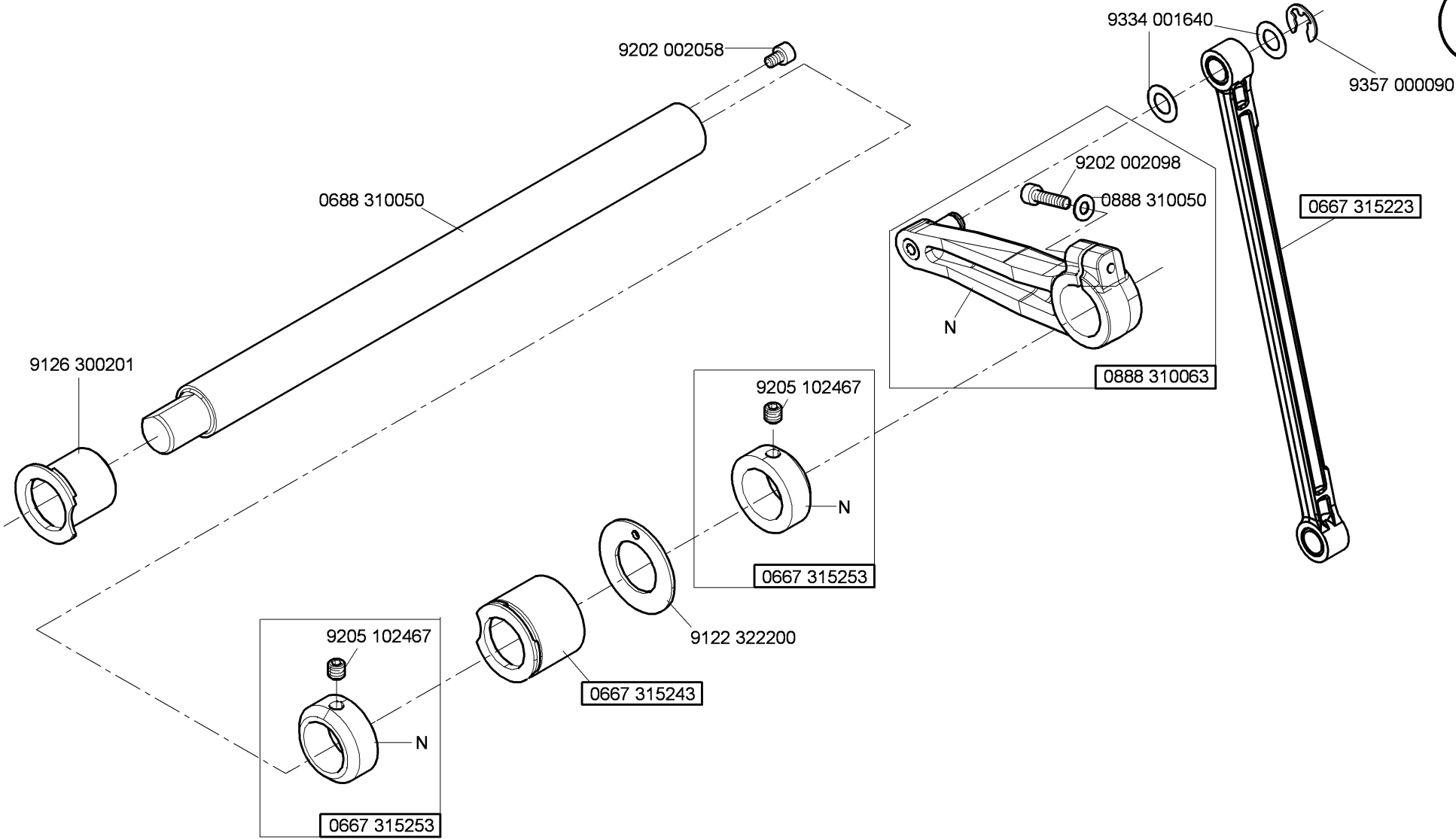

N - nicht als Einzelteil lieferbar  
not available as separate part

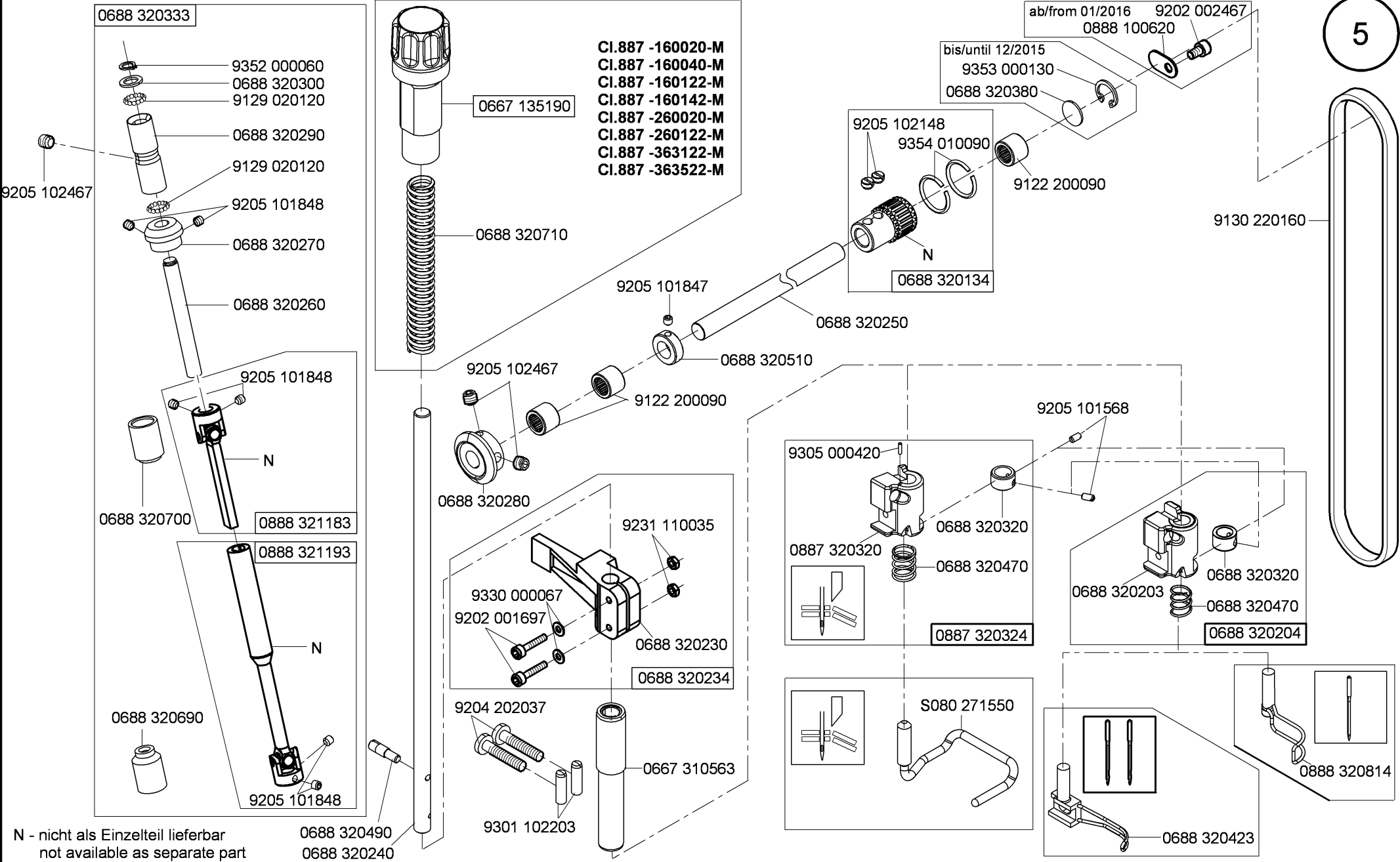

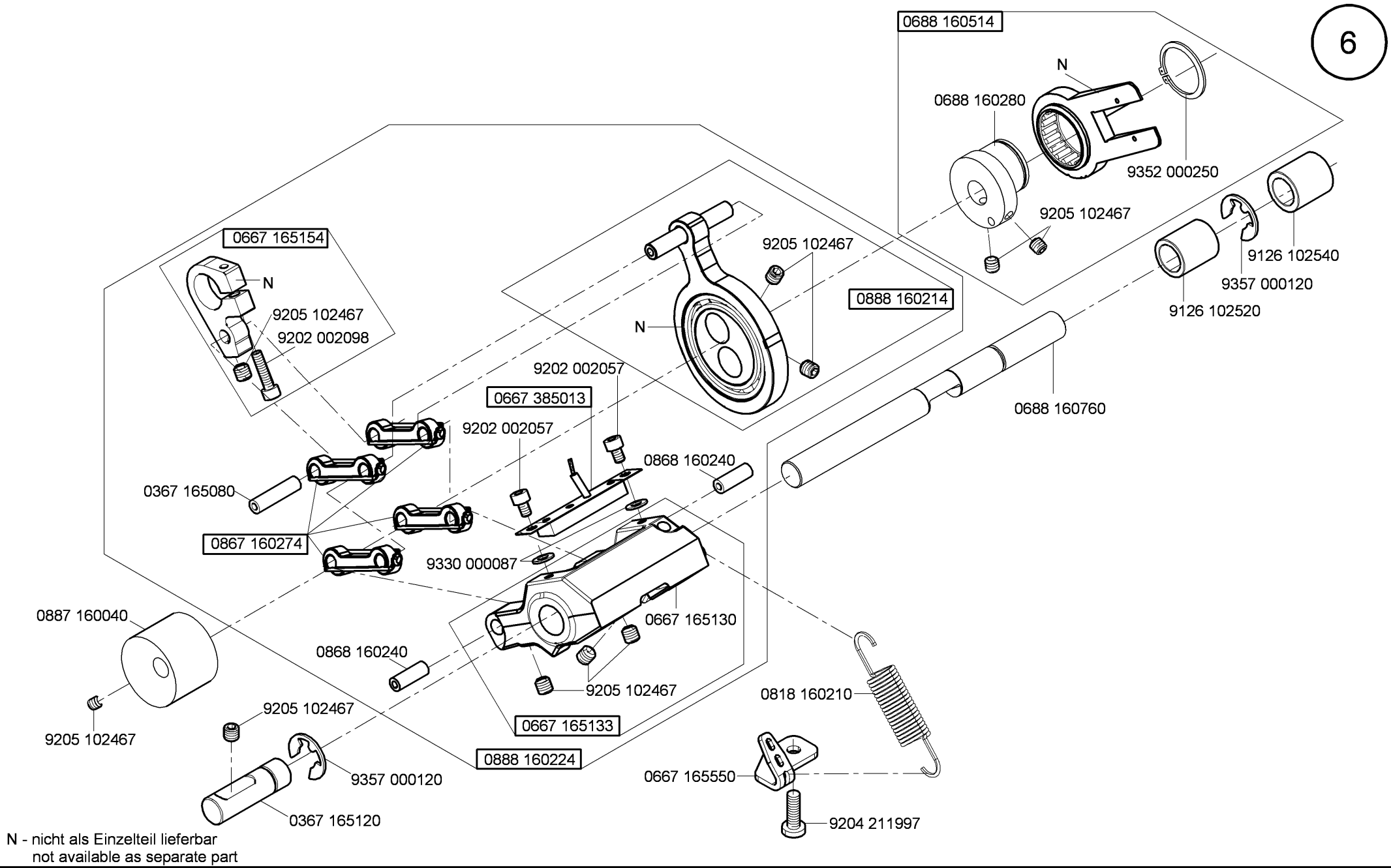

N - nicht als Einzelteil lieferbar  
not available as separate part

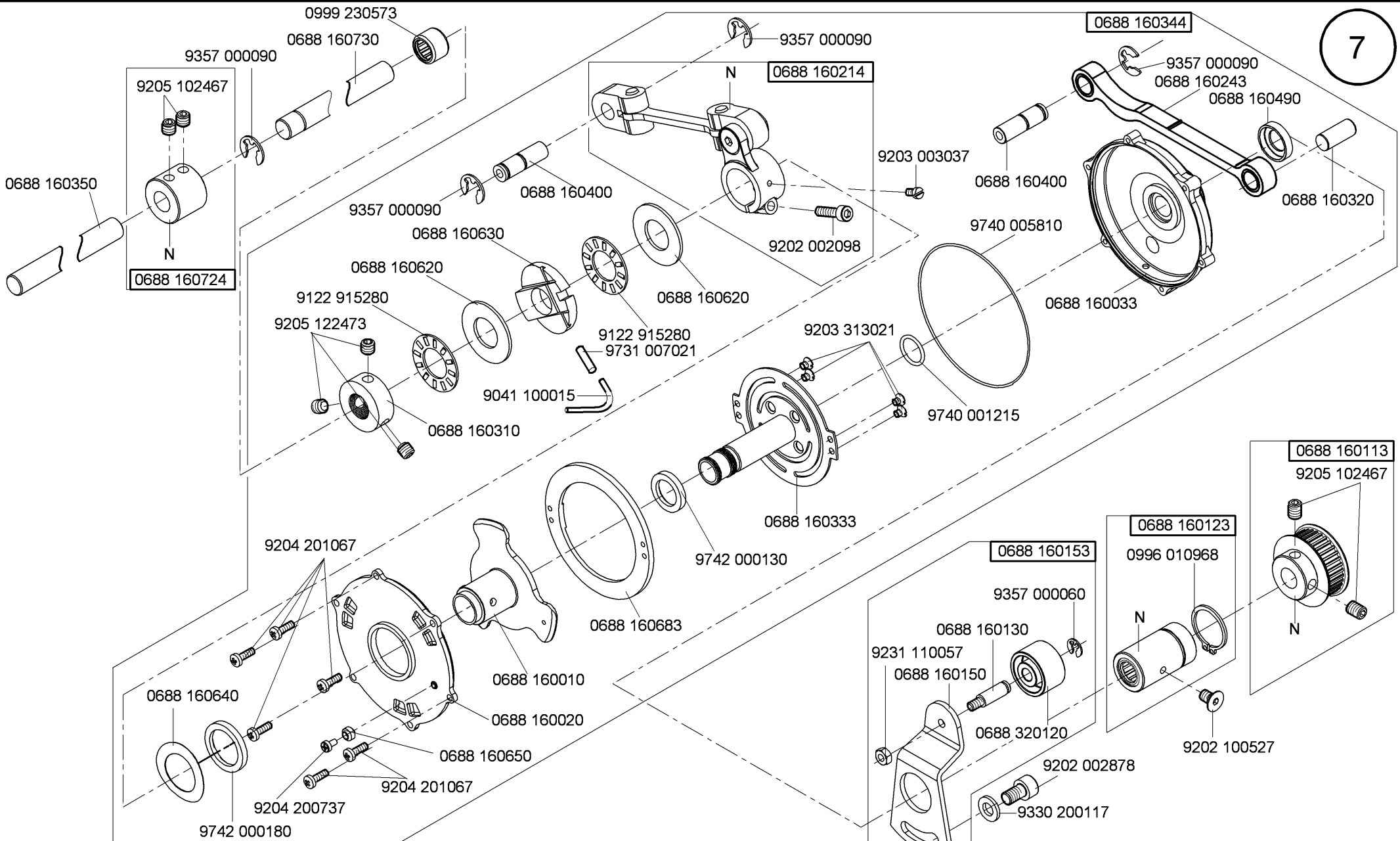

N - nicht als Einzelteil lieferbar  
not available as separate part

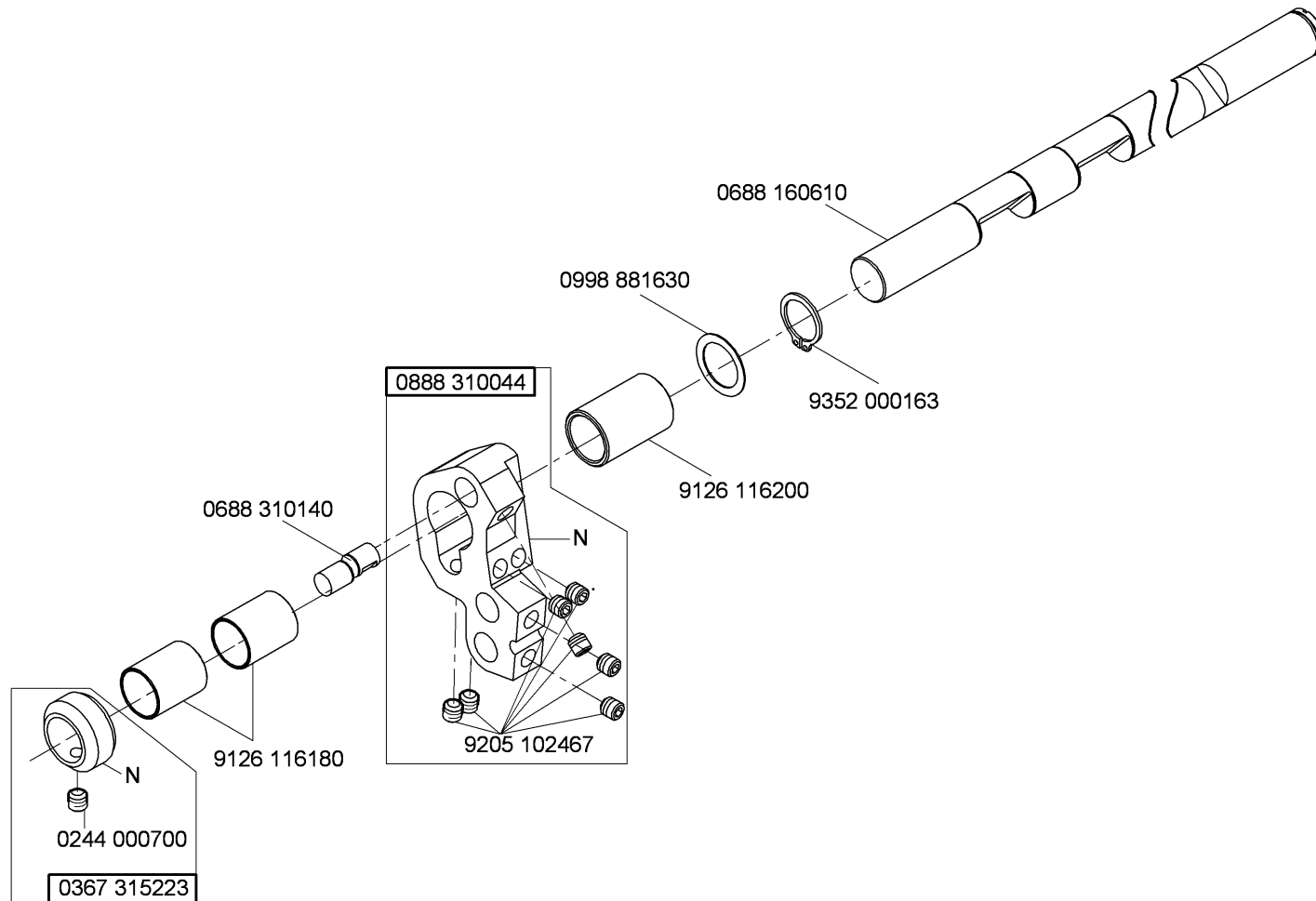

N - nicht als Einzelteil lieferbar  
not available as separate part

CI.887 -160020-M  
CI.887 -160040-M  
CI.887 -160122-M  
CI.887 -160142-M  
CI.887 -160542-M

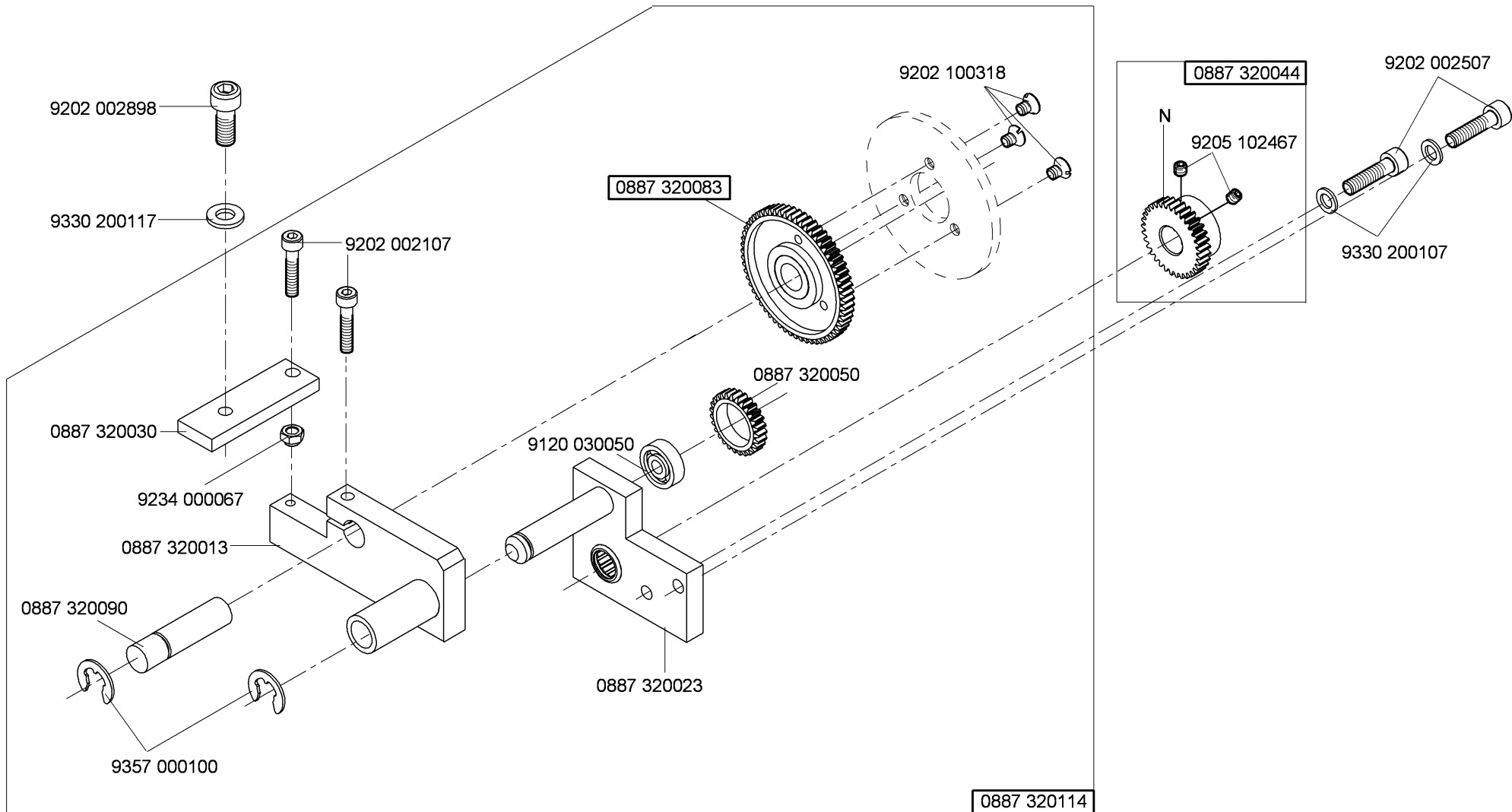

N - nicht als Einzelteil lieferbar  
not available as separate part

CI.887 -260020-M  
CI.887 -260122-M  
CI.887 -363122-M  
CI.887 -363522-M

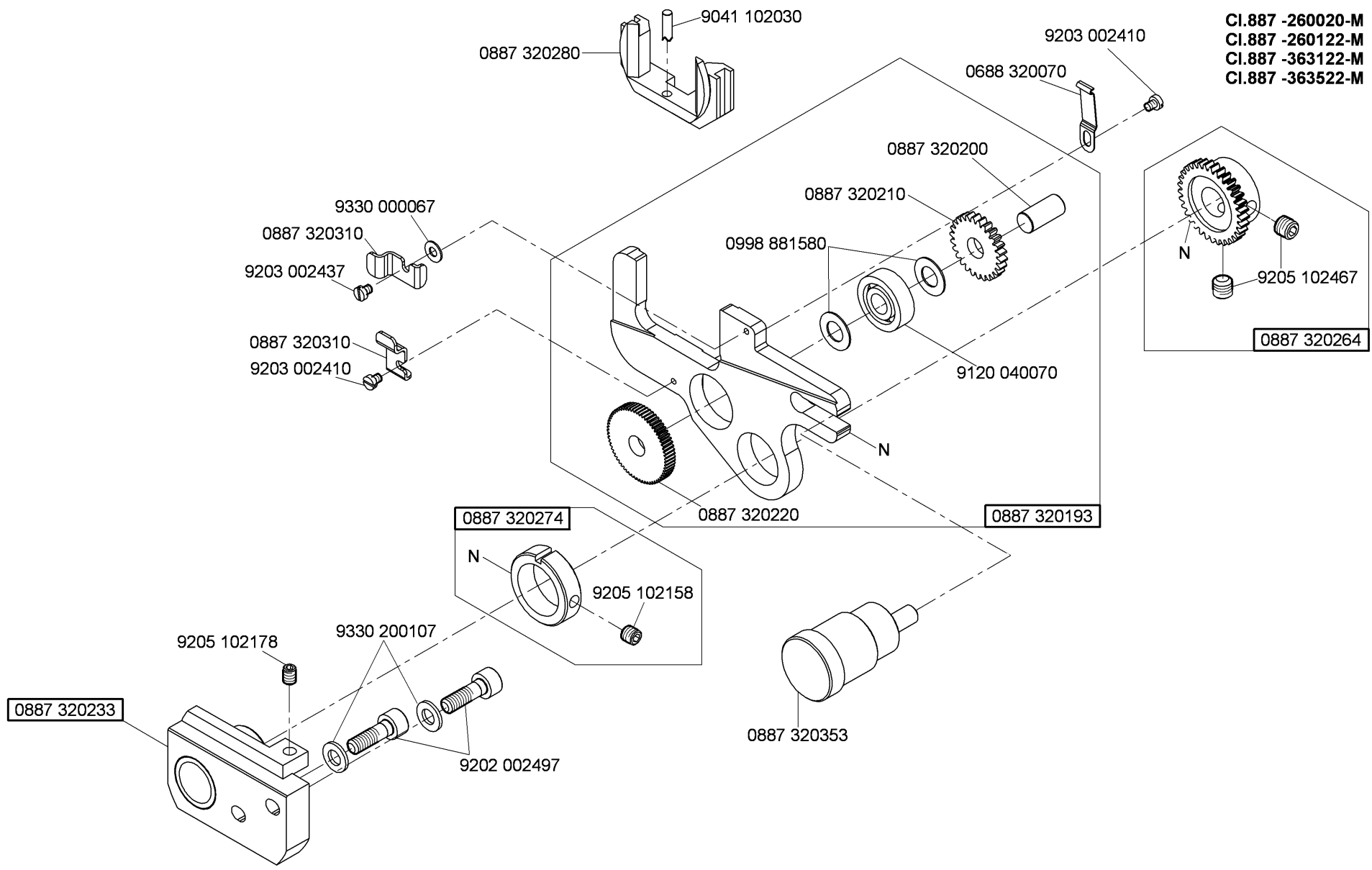



N - nicht als Einzelteil lieferbar  
not available as separate part

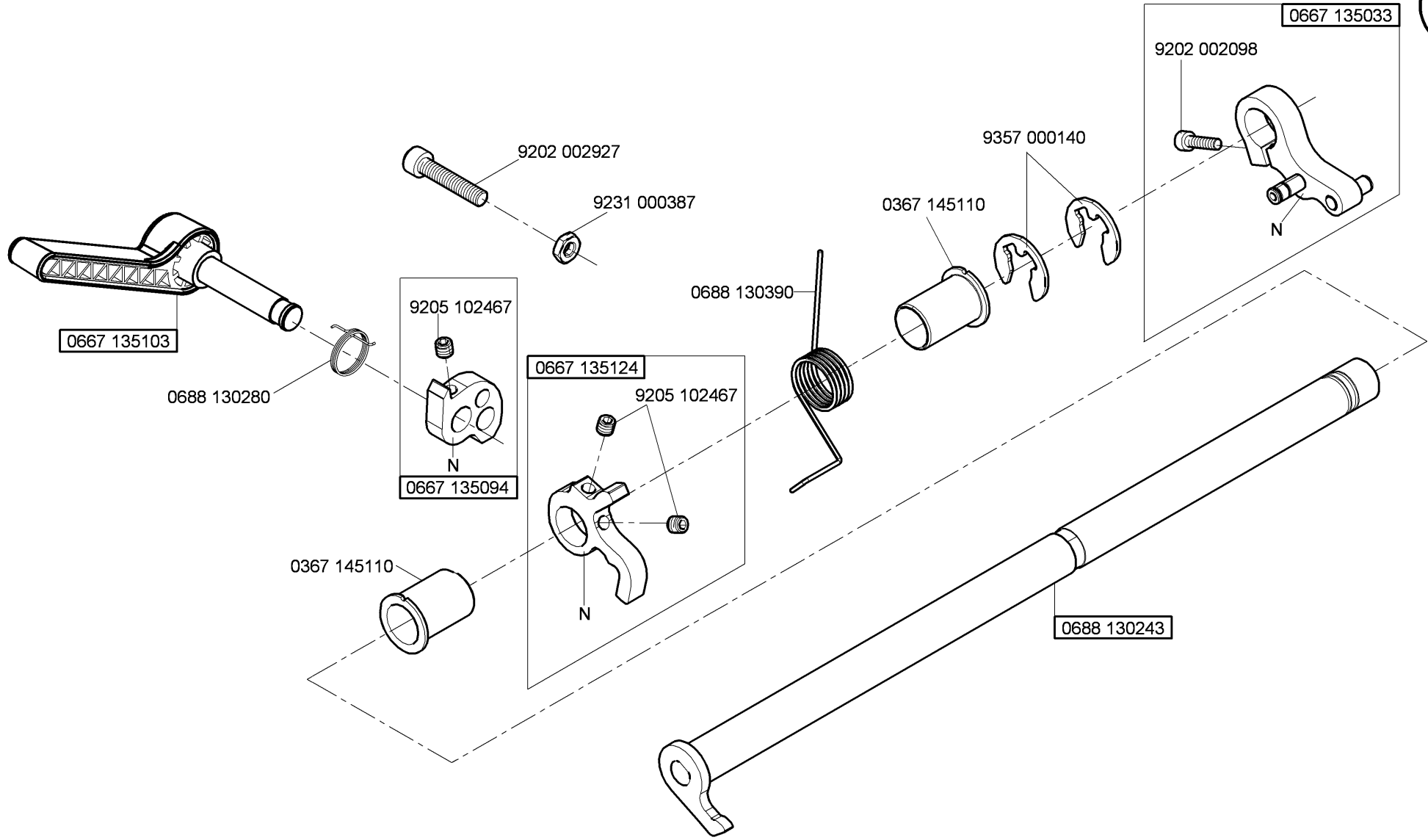

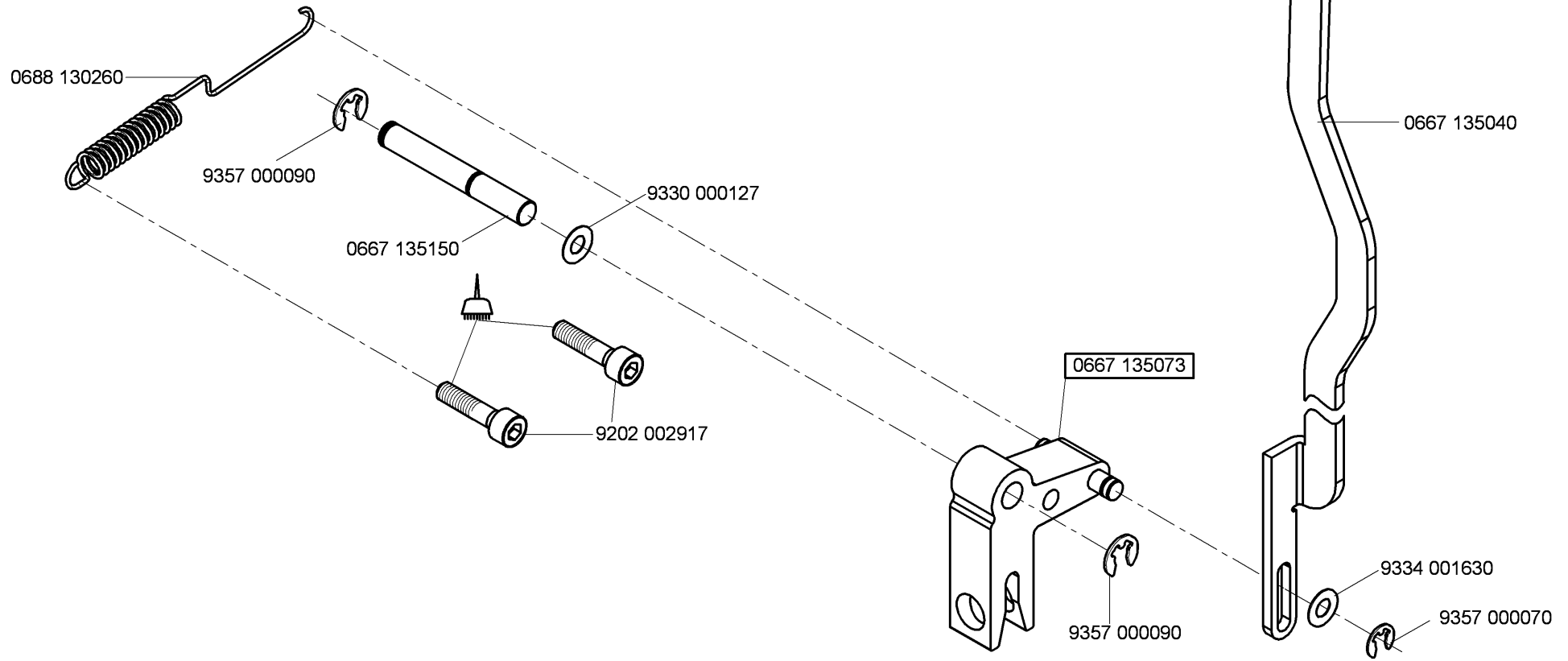

N - nicht als Einzelteil lieferbar  
not available as separate part



N - nicht als Einzelteil lieferbar  
not available as separate part  -kleben -stick

CI.887 -160122-M  
CI.887 -160142-M  
CI.887 -260122-M  
CI.887 -363122-M

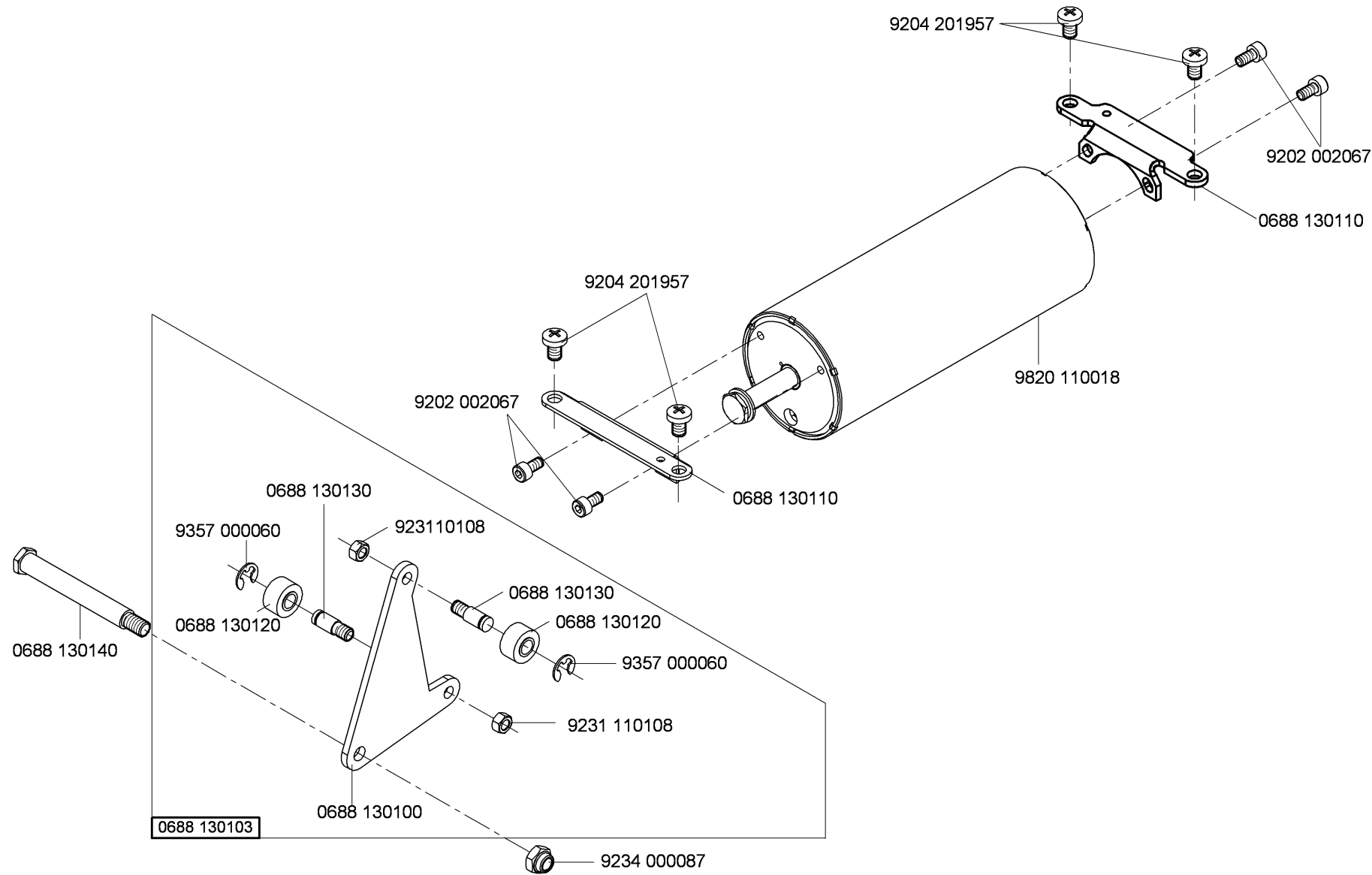

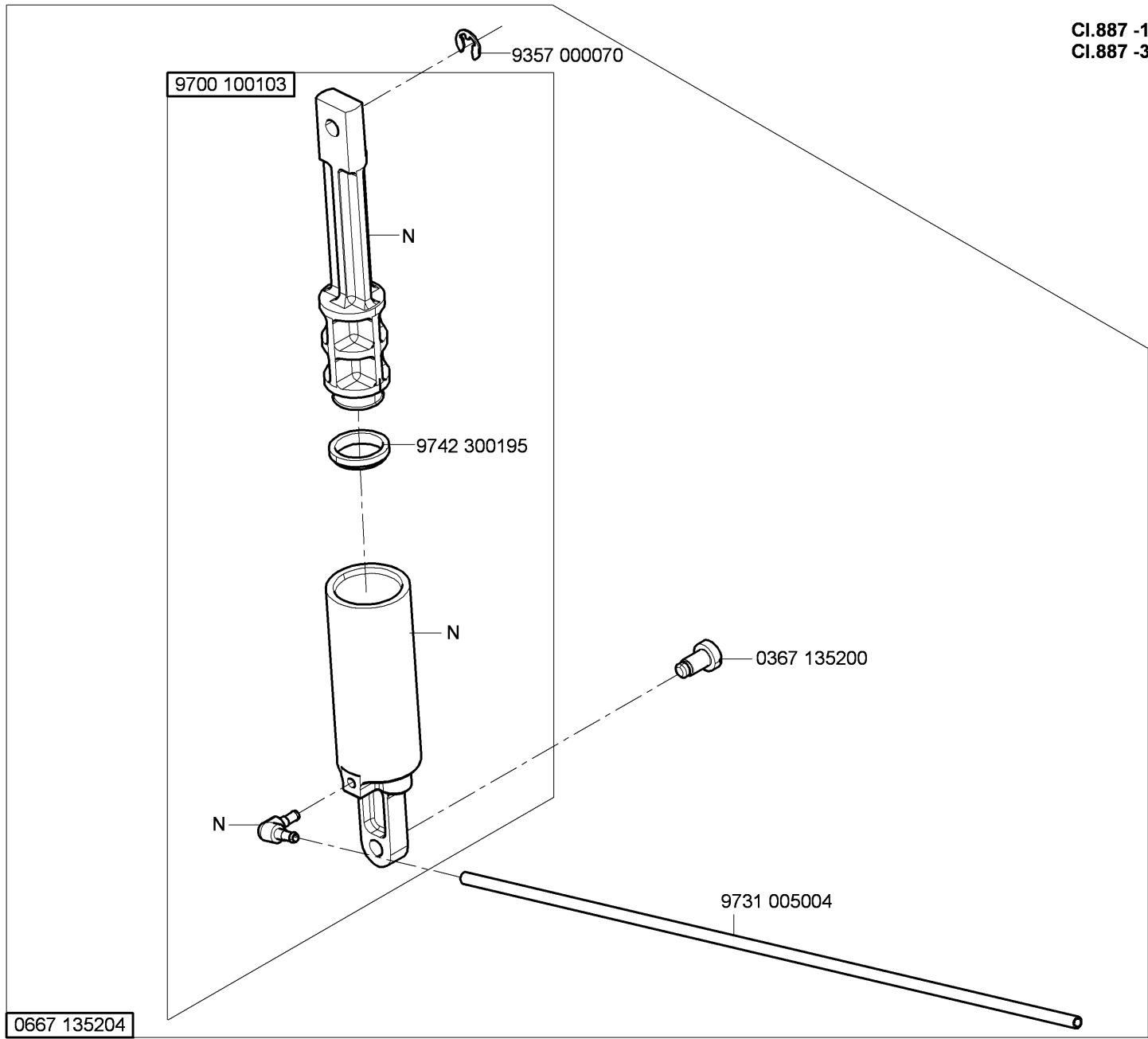

N - nicht als Einzelteil lieferbar  
not available as separate part

0667 135204

CI.887 -160020-M  
 CI.887 -160122-M  
 CI.887 -260020-M  
 CI.887 -260122-M  
 CI.887 -363122-M  
 CI.887 -363522-M

0245 001660 A

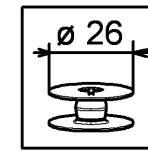
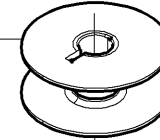

0888 150754

0888 150734

0767 150590  
(0,35)

0992 023560

0992 023577

0467 150120  
(0,45)

N

0467 150440  
(0,3)

auf Wunsch  
on request

0992 016580

0992 016580

0467 150040

9203 211837

0467 150130

9205 102477

0667 156190

9205 102477

0667 156320

bis/until 12/2015

0888 150740

ab/from 01/2016

0867 151050

0998 882080

9202 100535

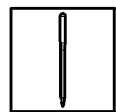

(1x)

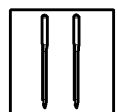

(2x)

N - nicht als Einzelteil lieferbar  
not available as separate part

auf Wunsch  
on request

0667 150870  
(0,45)

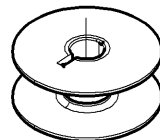

0667 150830

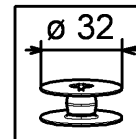

CI.887 -160040-M  
CI.887 -160142-M  
CI.887 -160542-M

0667 155634

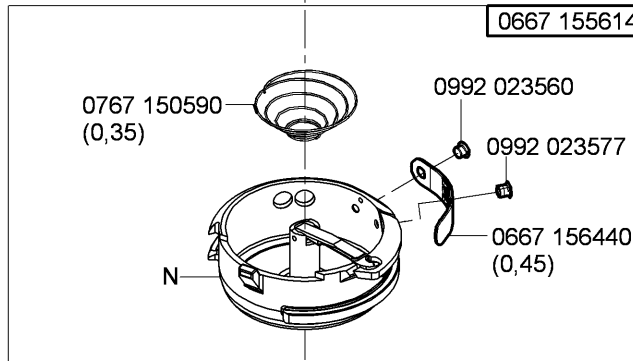

0767 150590  
(0,35)

0992 023560

0992 023577

0667 156440  
(0,45)

N

auf Wunsch  
on request



0467 150440  
(0,3)

0667 156210

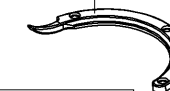

auf Wunsch  
on request

0867 150290

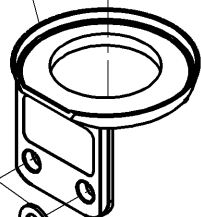

0998 882080

9202 100535

0992 016580

0992 016580

0667 150840

9203 211837

0667 150850

9205 102477

0667 156180

9205 102477

0667 156330

N

N - nicht als Einzelteil lieferbar  
not available as separate part

- CI.887 -160020-M
- CI.887 -160040-M
- CI.887 -160122-M
- CI.887 -160142-M
- CI.887 -160542-M
- CI.887 -260020-M
- CI.887 -260122-M

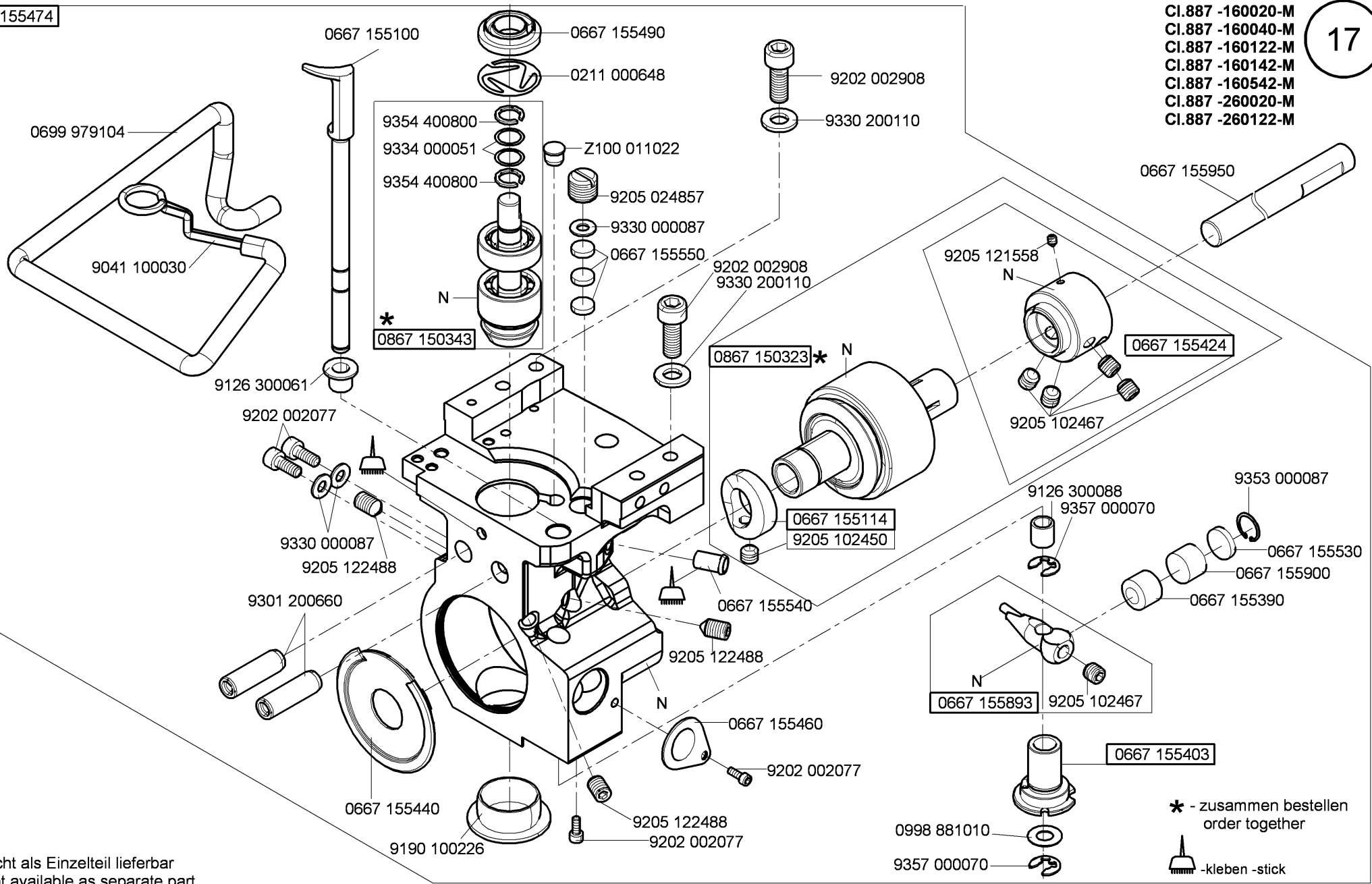

N - nicht als Einzelteil lieferbar  
not available as separate part

\* - zusammen bestellen  
order together

 -kleben -stick



CI.887 -260020-M  
 CI.887 -260122-M  
 CI.887 -363122-M  
 CI.887 -363522-M

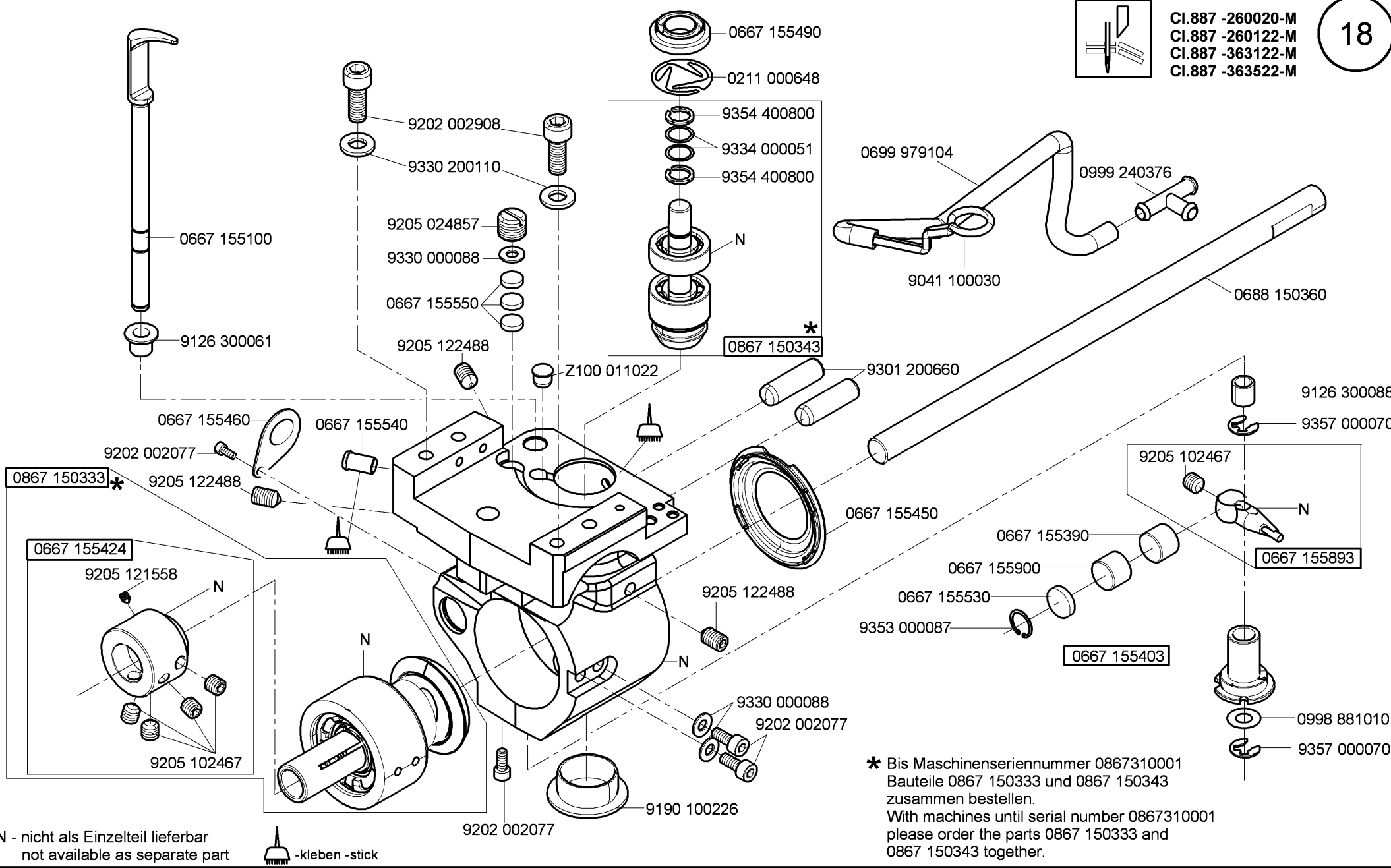

N - nicht als Einzelteil lieferbar  
 not available as separate part

-kleben -stick

\* Bis Maschinenseriennummer 0867310001  
 Bauteile 0867 150333 und 0867 150343  
 zusammen bestellen.  
 With machines until serial number 0867310001  
 please order the parts 0867 150333 and  
 0867 150343 together.



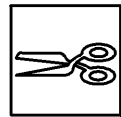

CI.887 -160122-M  
CI.887 -160142-M  
CI.887 -160542-M  
CI.887 -260122-M  
CI.887 -363122-M  
CI.887 -363522-M

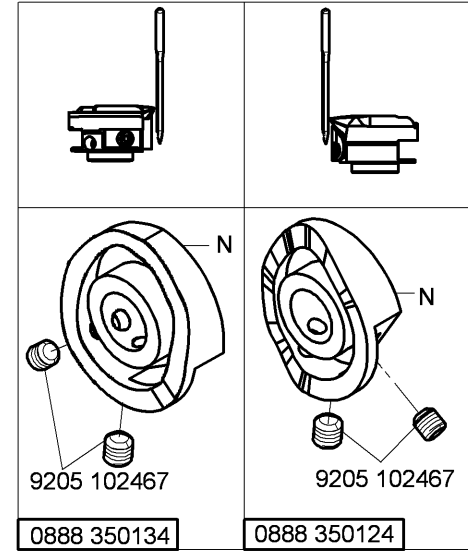
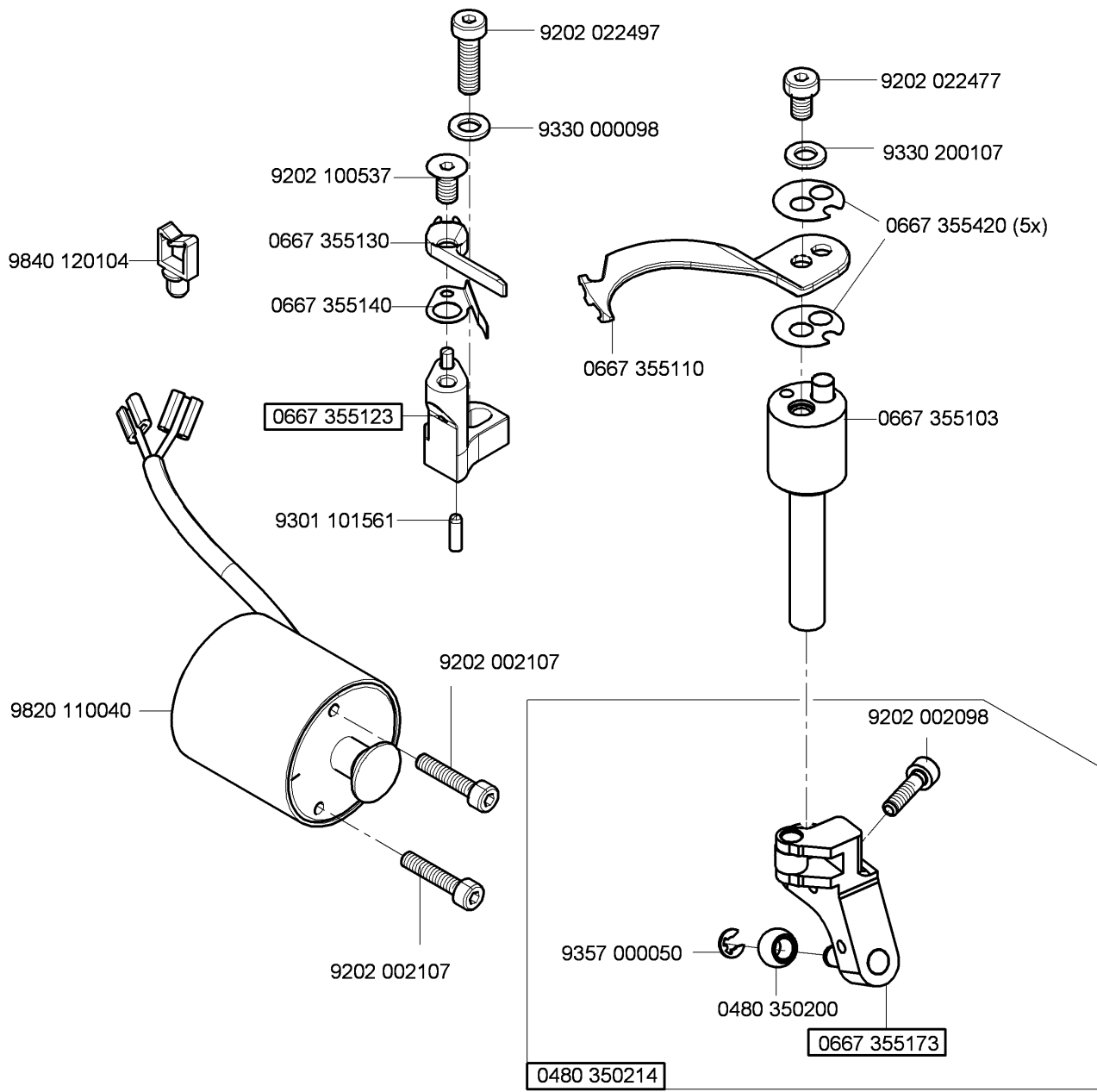

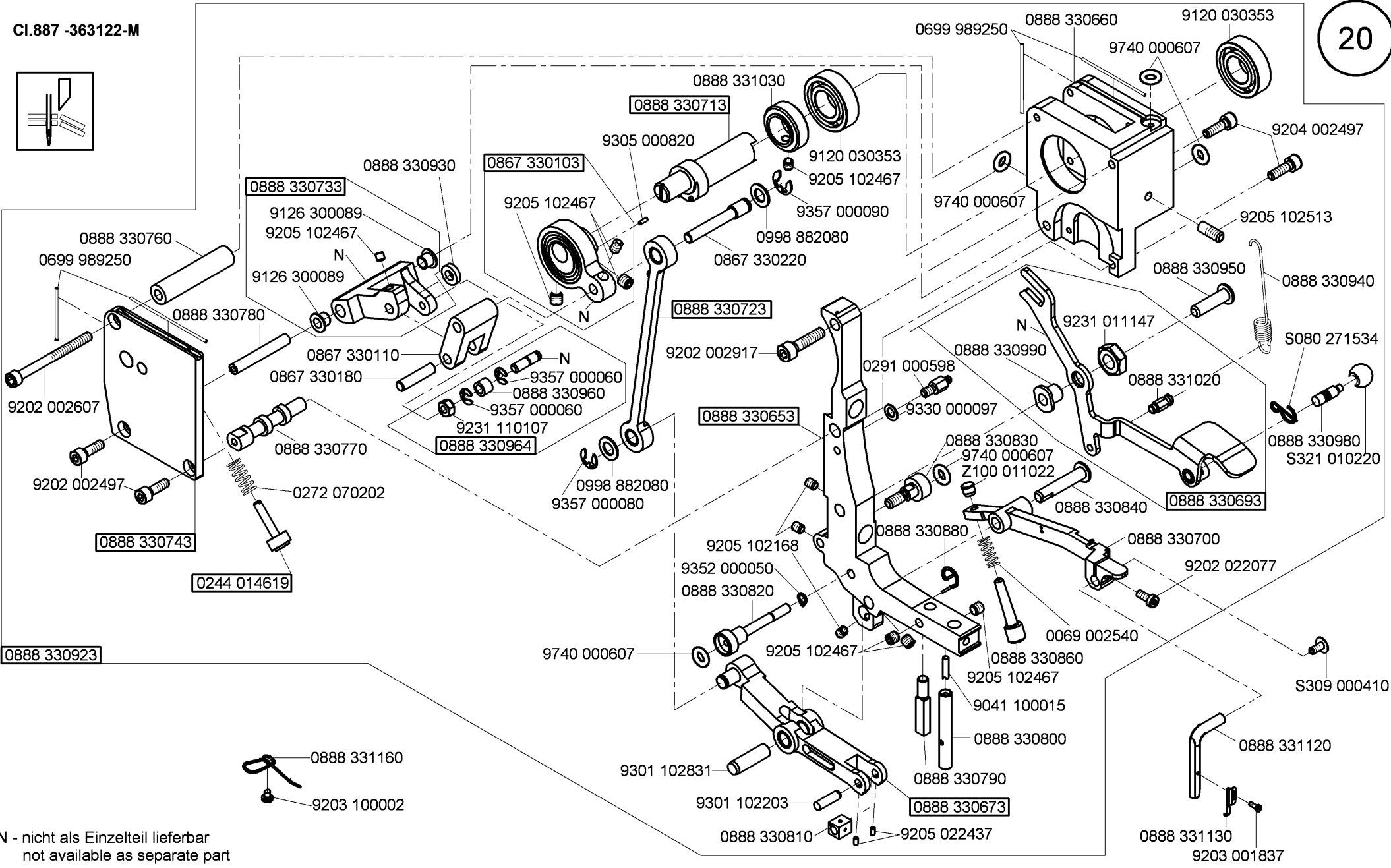
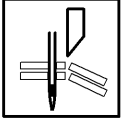

N - nicht als Einzelteil lieferbar  
not available as separate part

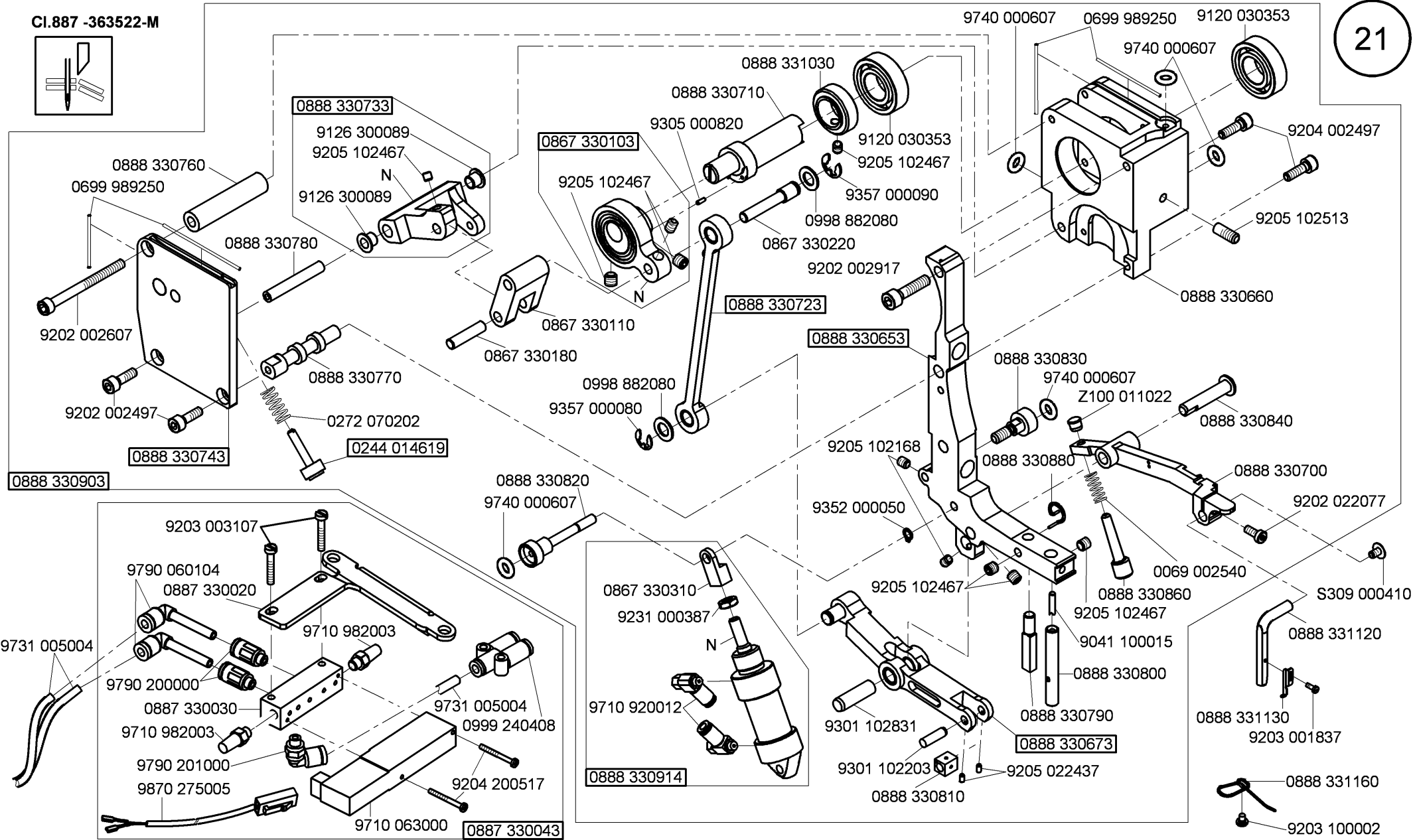
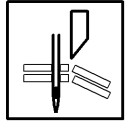

N - nicht als Einzelteil lieferbar  
not available as separate part

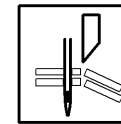

CI.887 -363122-M  
CI.887 -363522-M

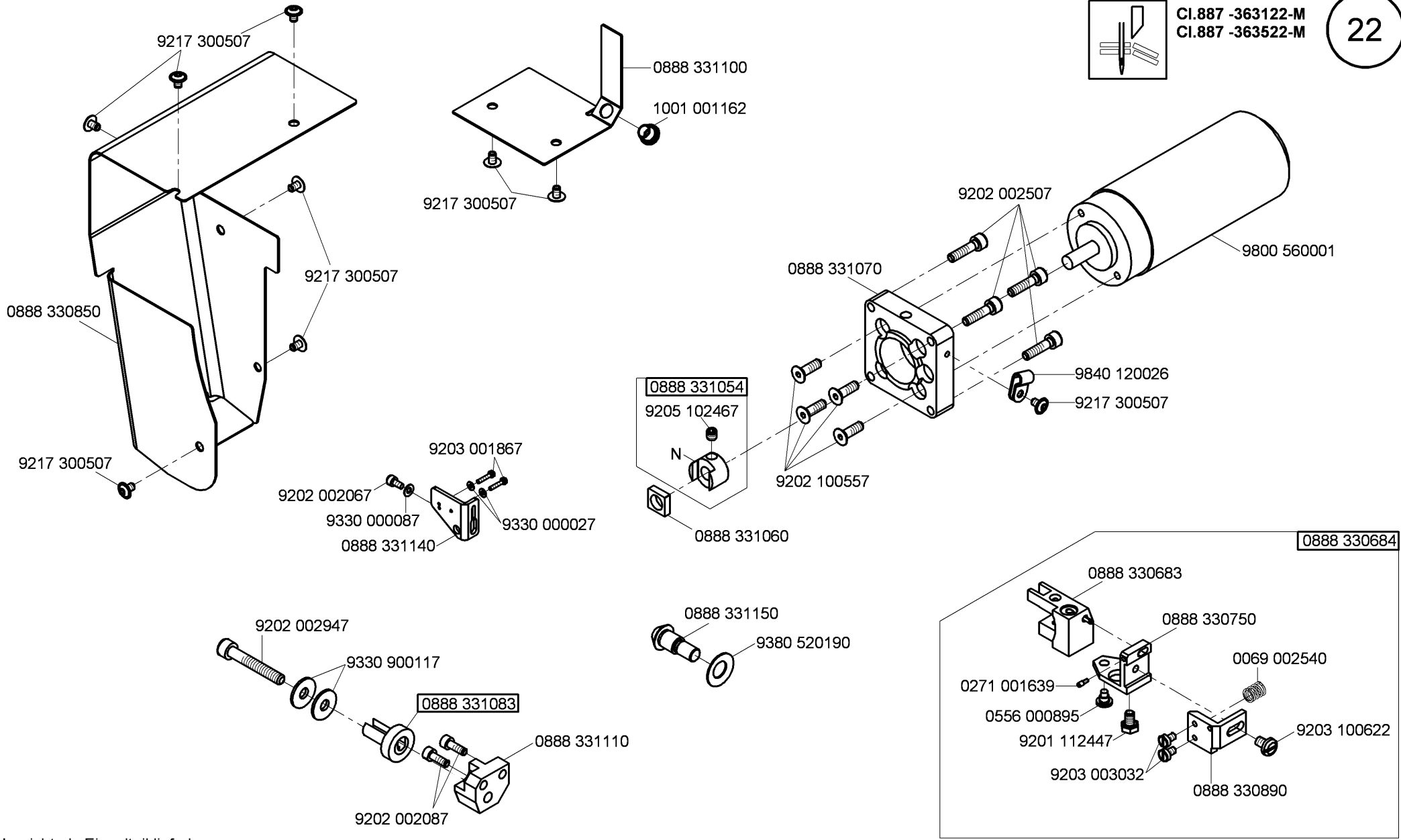

N - nicht als Einzelteil lieferbar  
not available as separate part

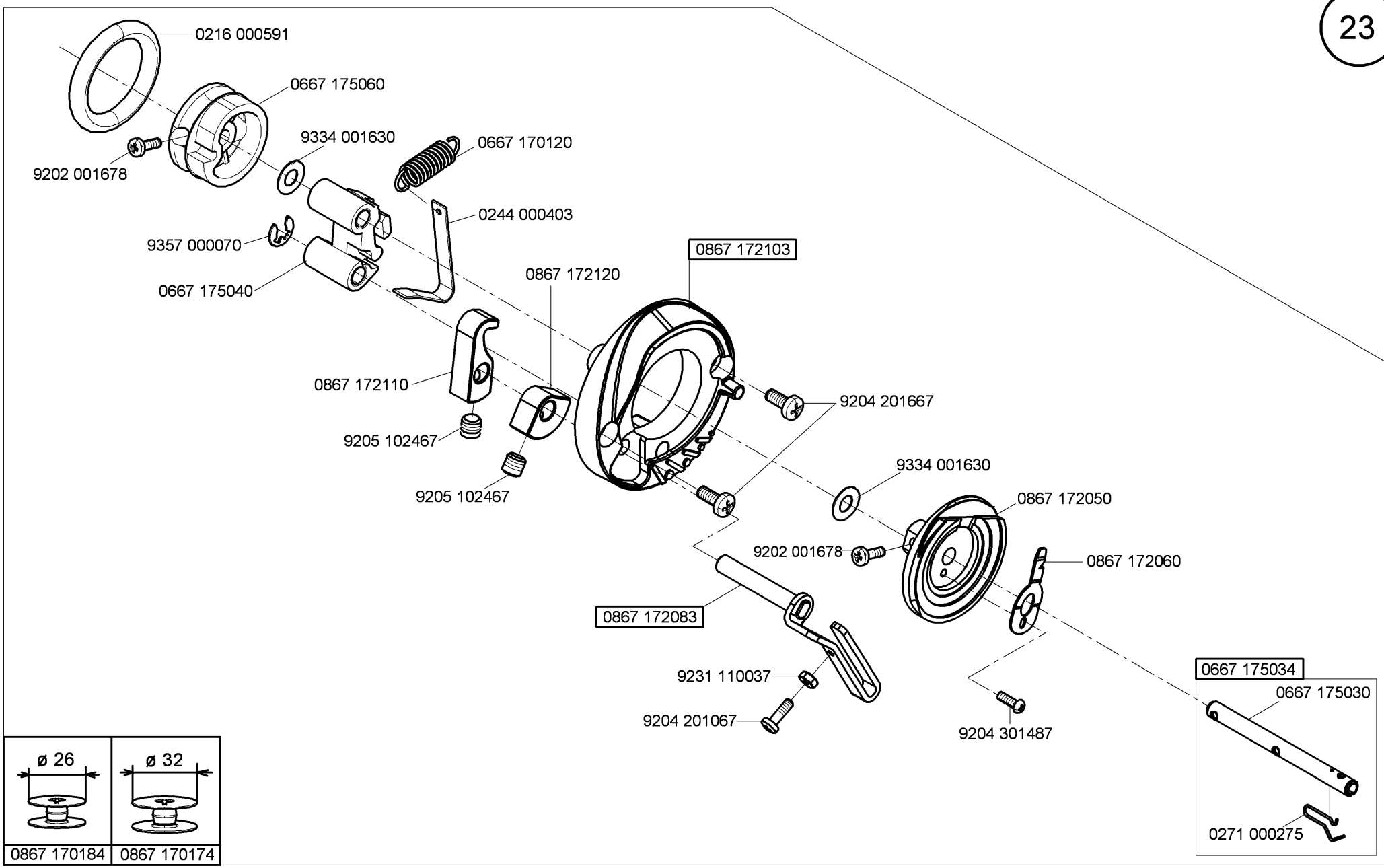

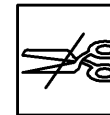

CI.887 -160020-M  
CI.887 -160040-M

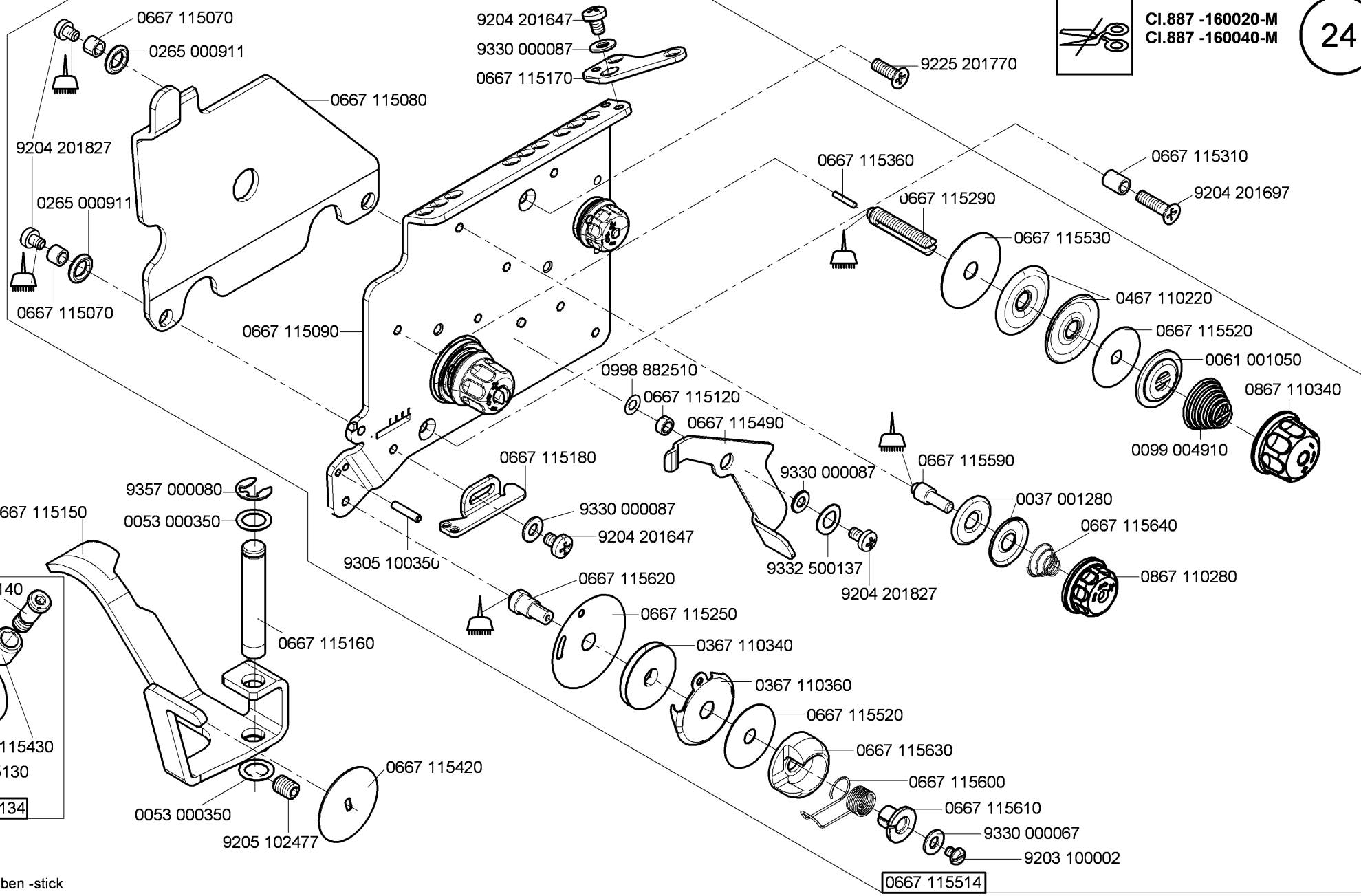

0667 115140

0667 115430

0667 115130

0667 115134

-kleben -stick

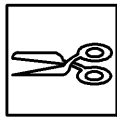

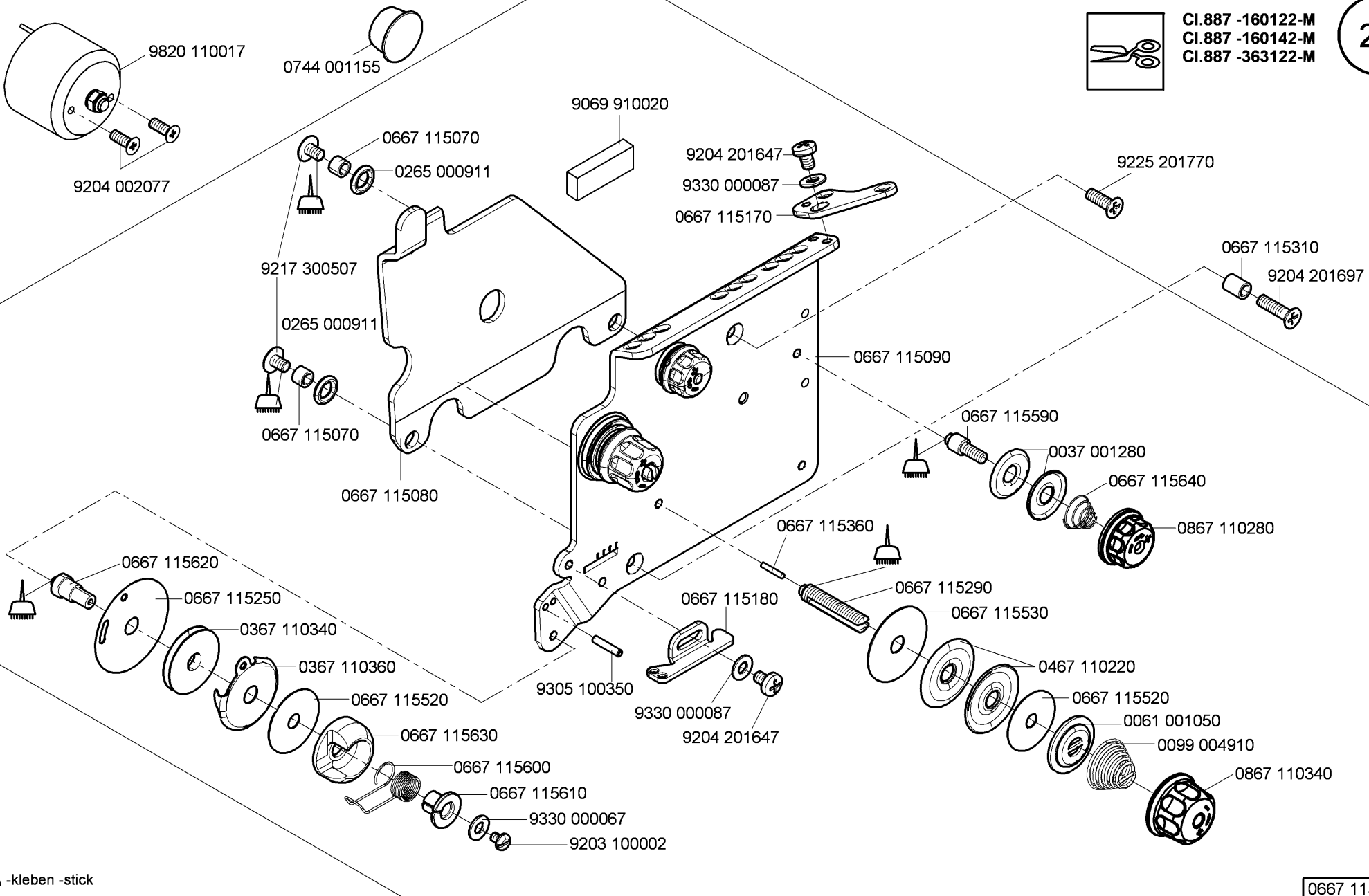

CI.887 -160122-M  
CI.887 -160142-M  
CI.887 -363122-M

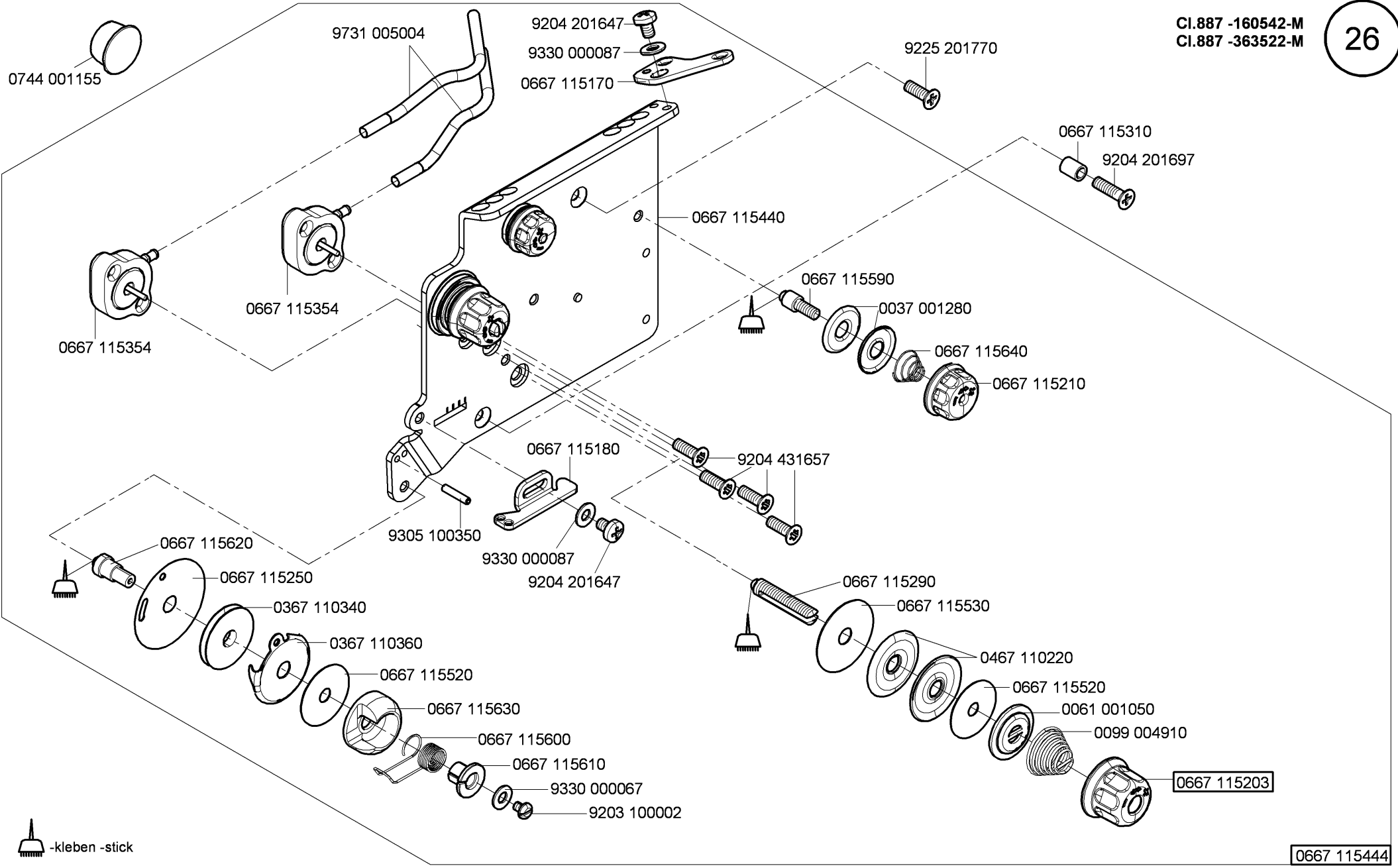

-kleben -stick

0667 115544



 -kleben -stick

0667 115444



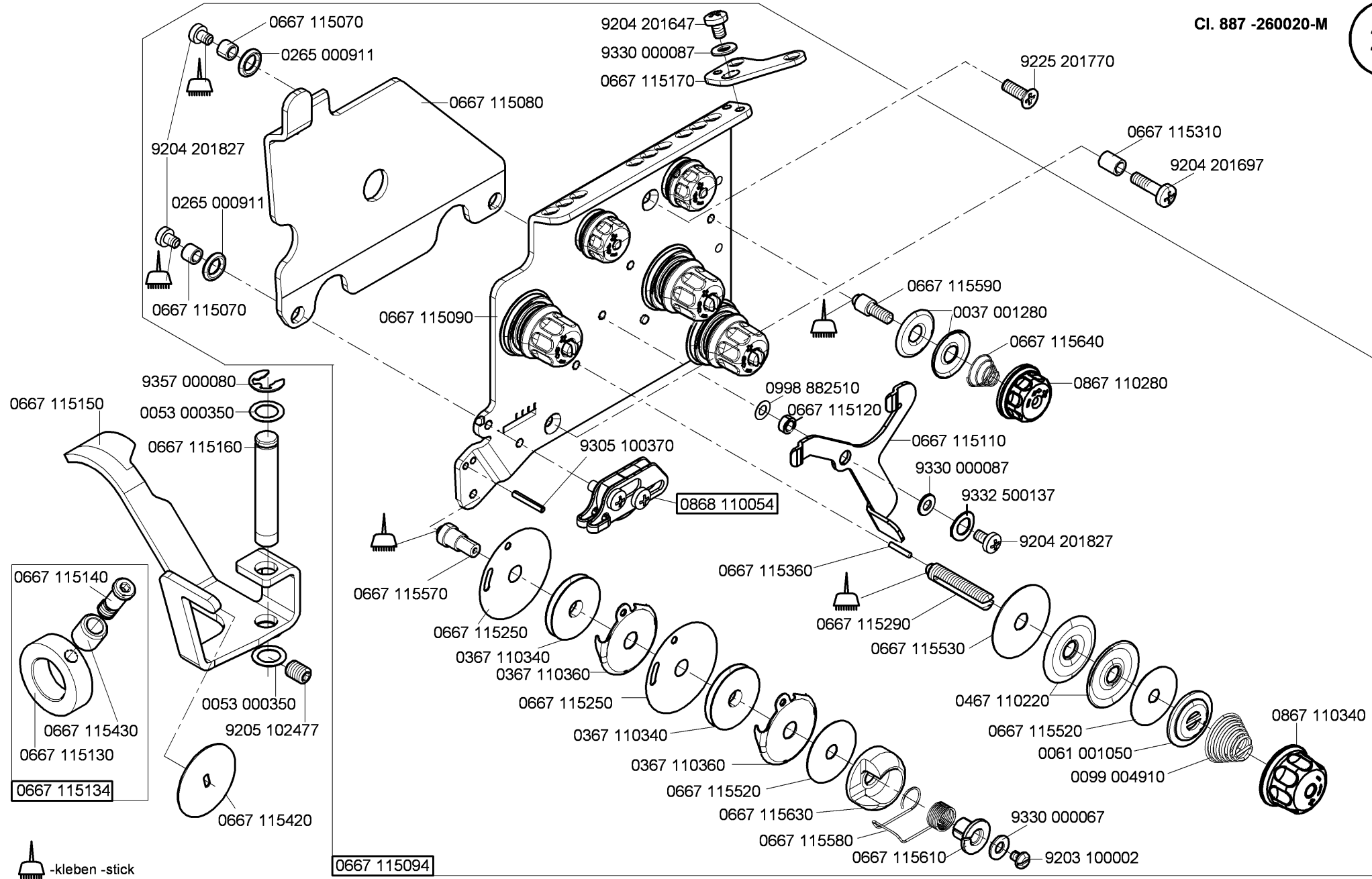

-kleben -stick

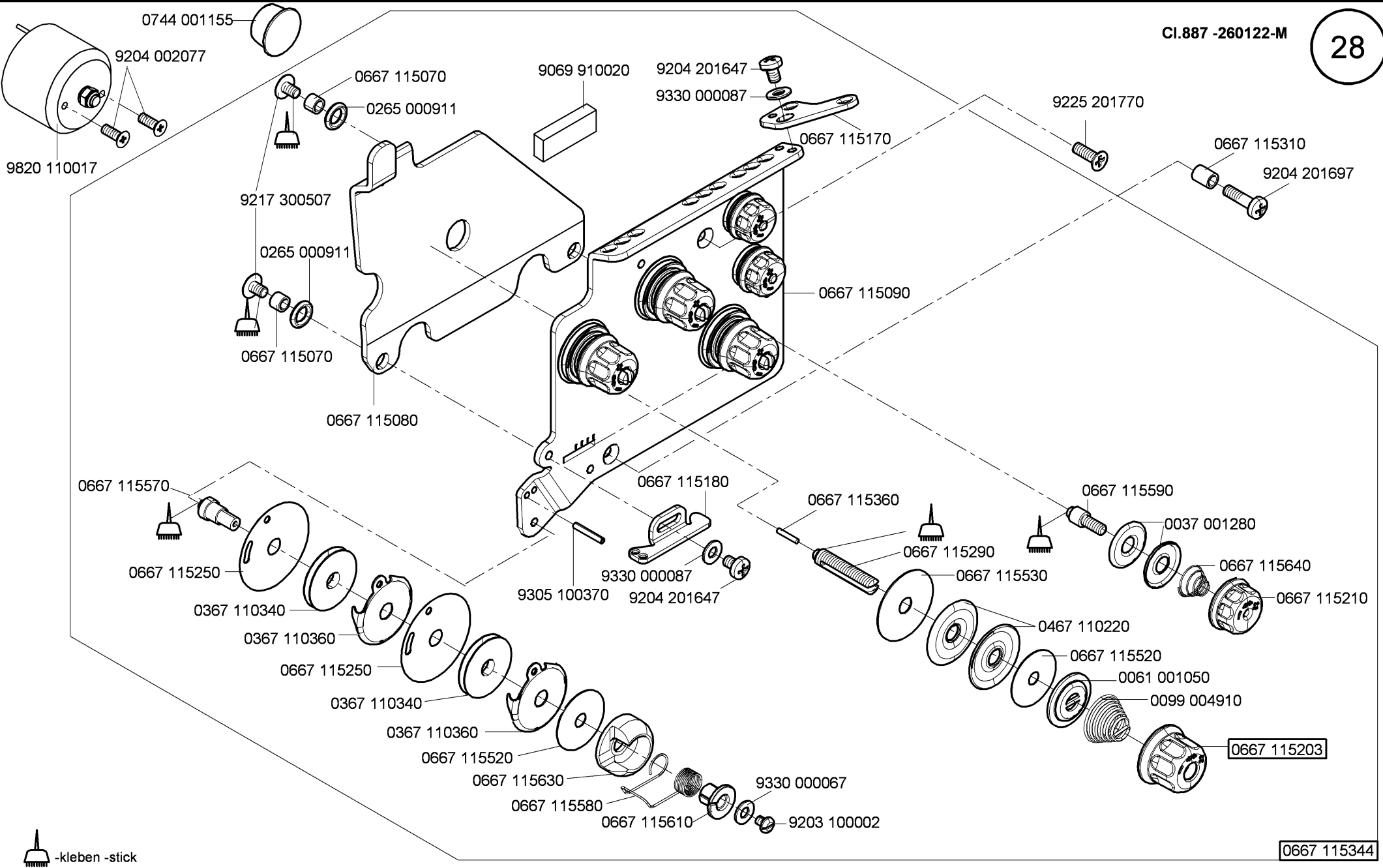

 -kleben -stick

CI.887 -160020-M  
CI.887 -160040-M  
CI.887 -160122-M  
CI.887 -160142-M  
CI.887 -260020-M  
CI.887 -260122-M  
CI.887 -363122-M

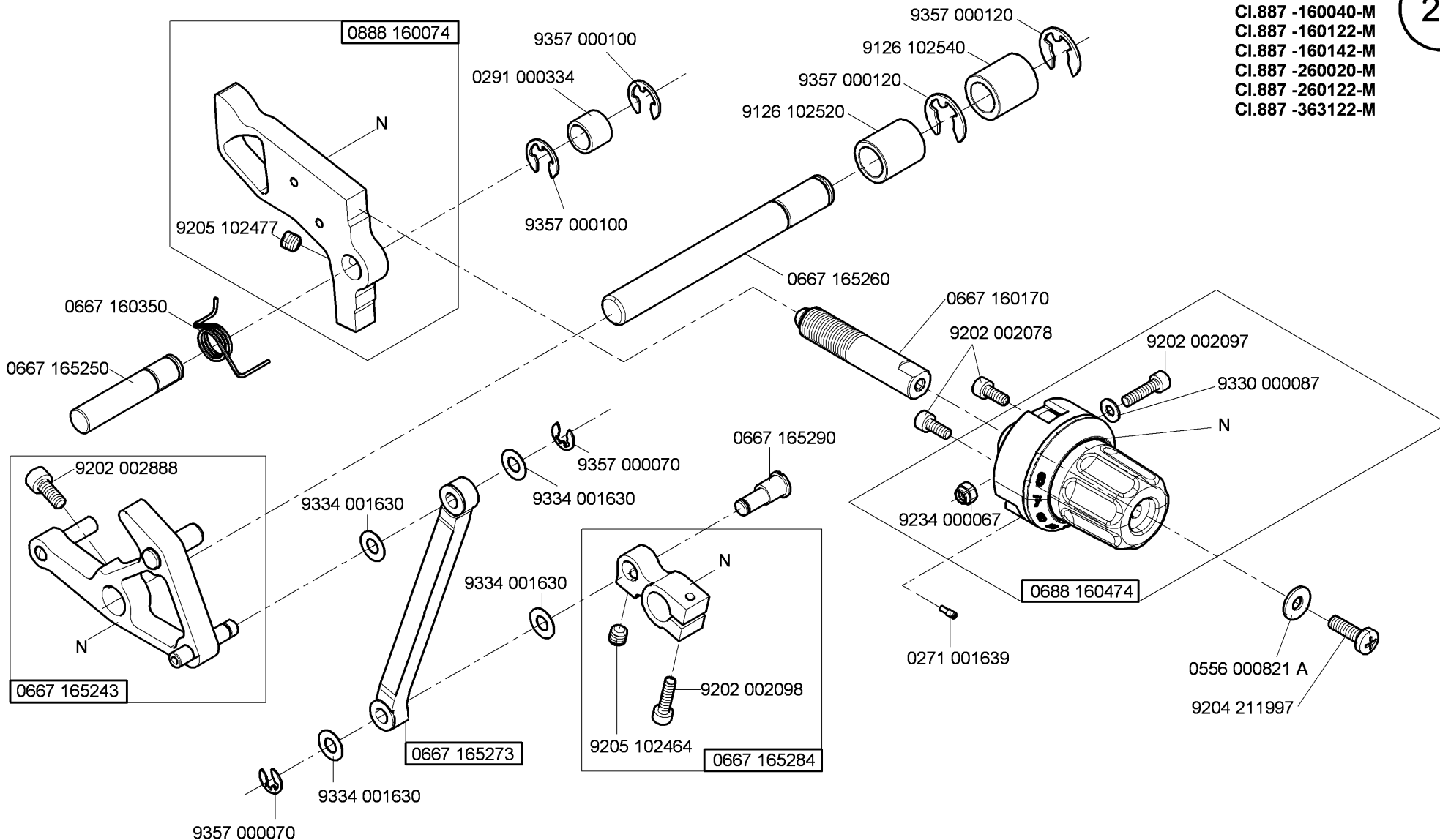

N - nicht als Einzelteil lieferbar  
not available as separate part

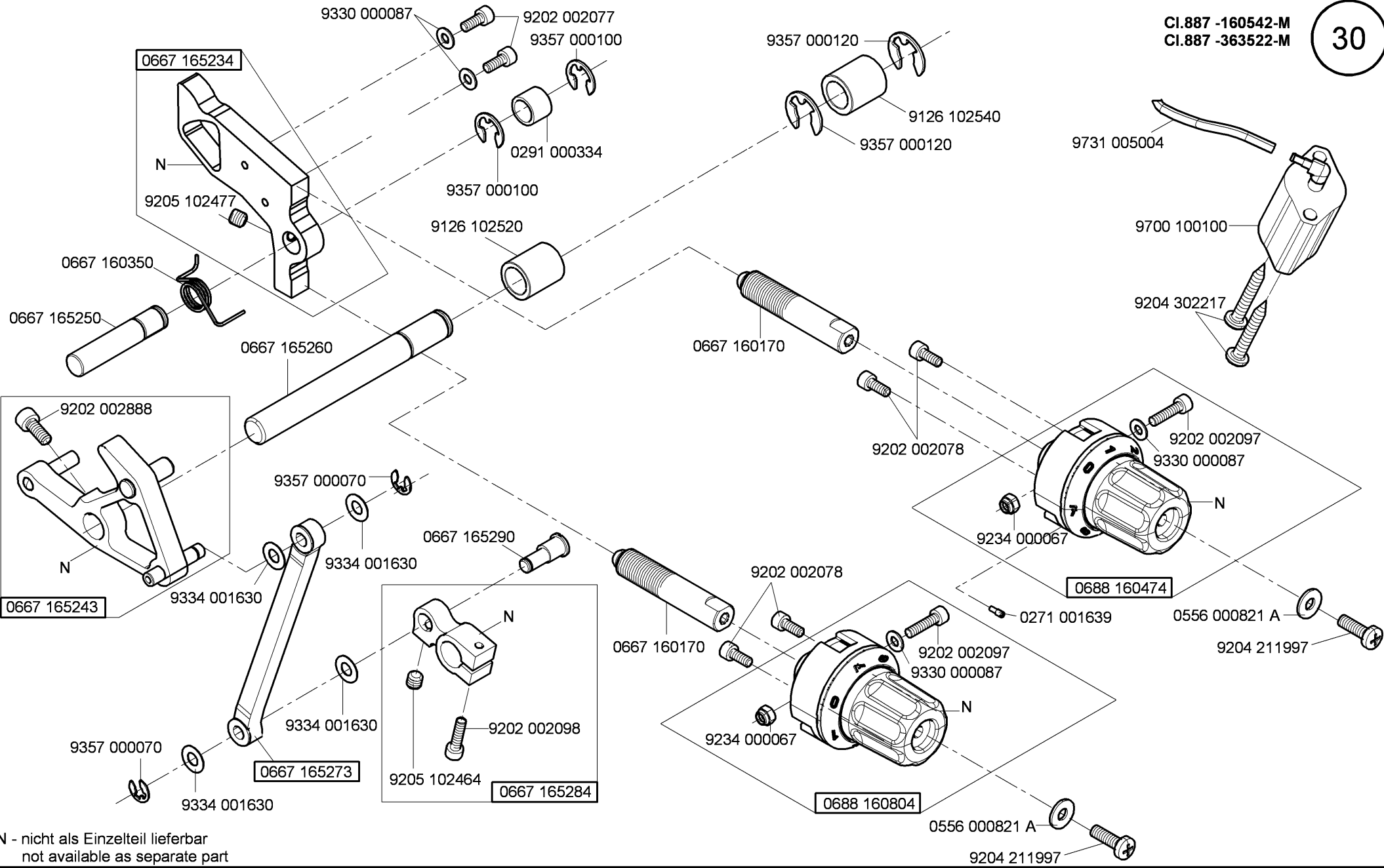

N - nicht als Einzelteil lieferbar  
not available as separate part

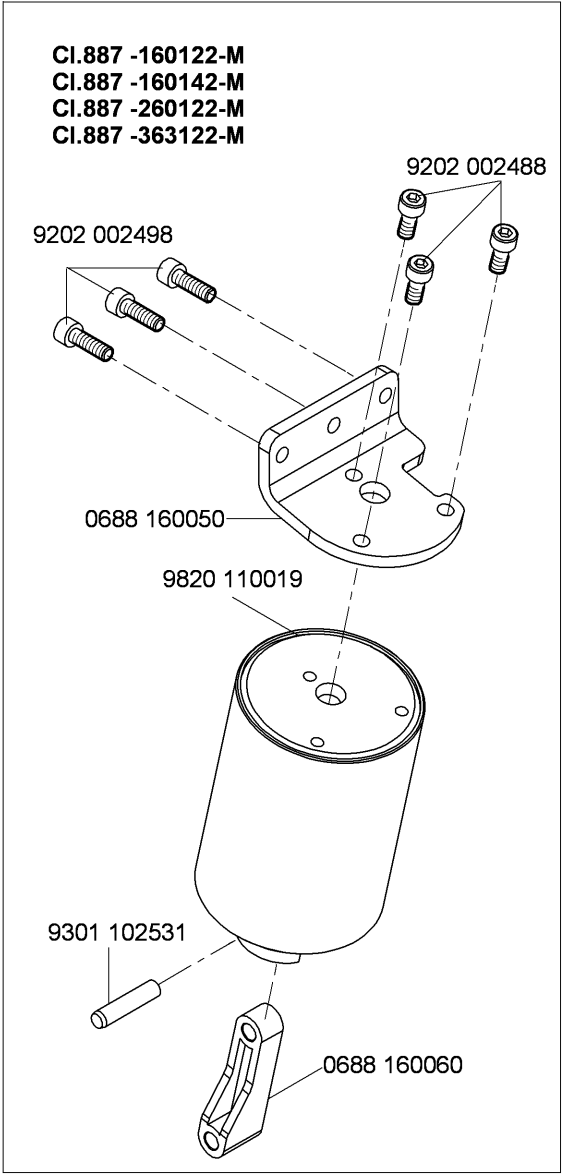
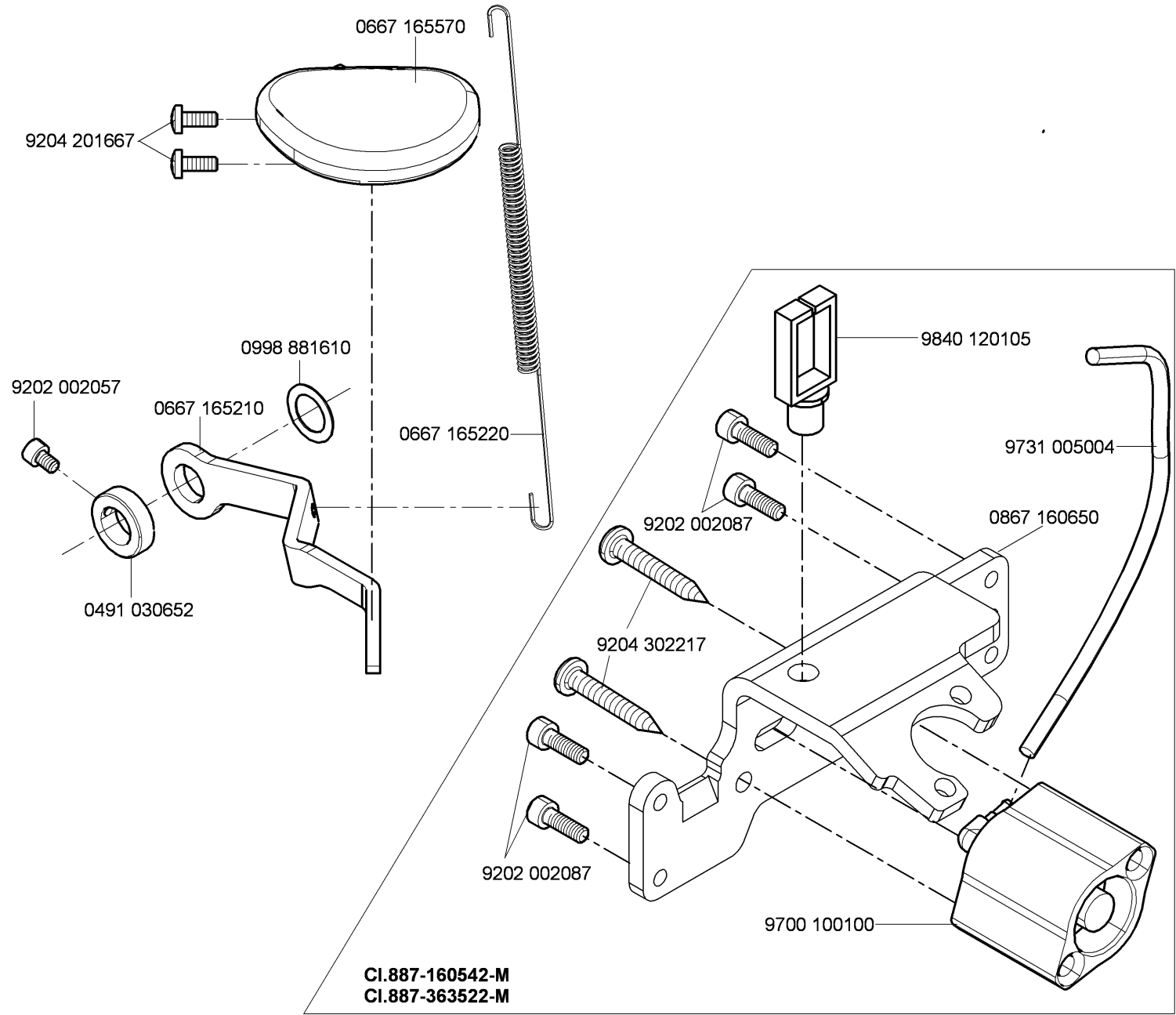

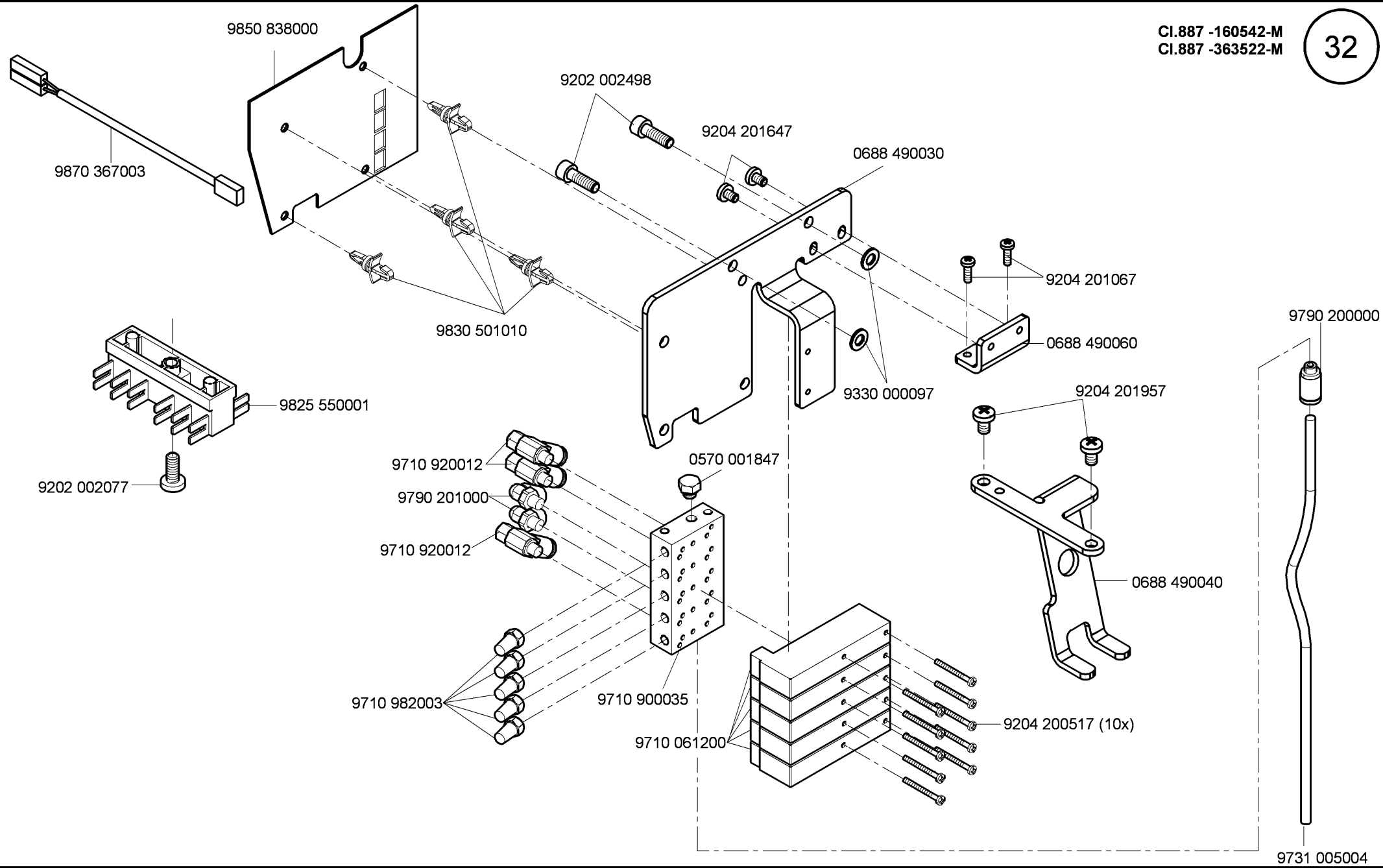

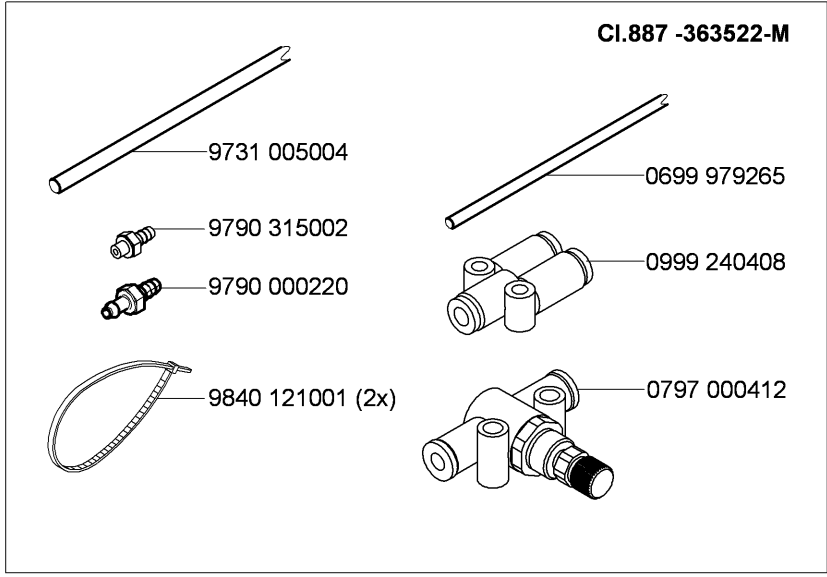
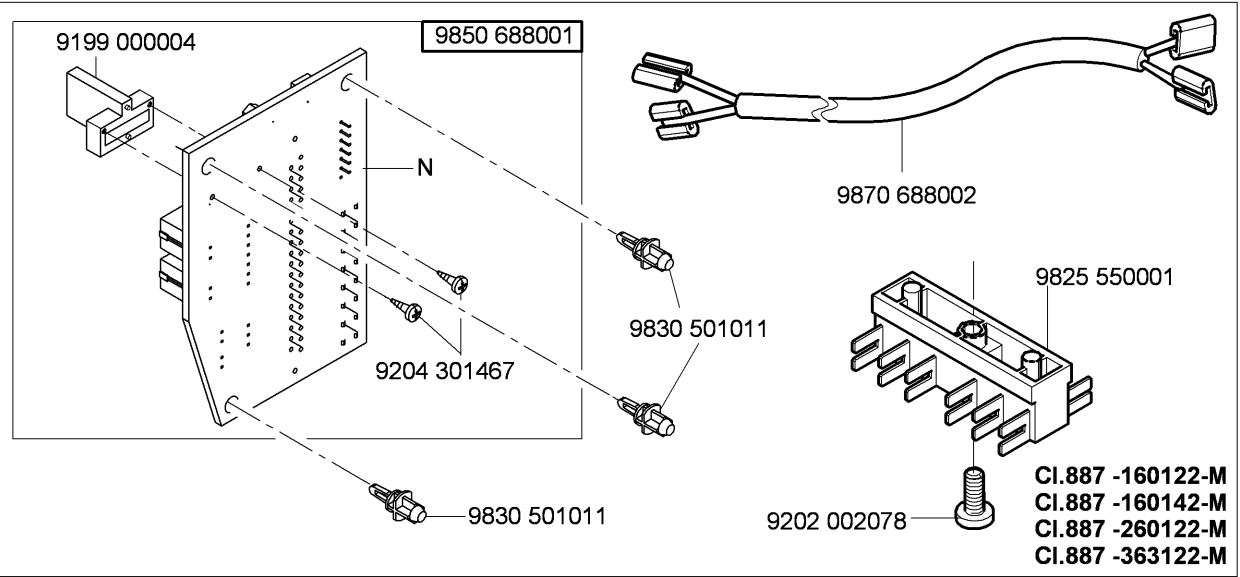
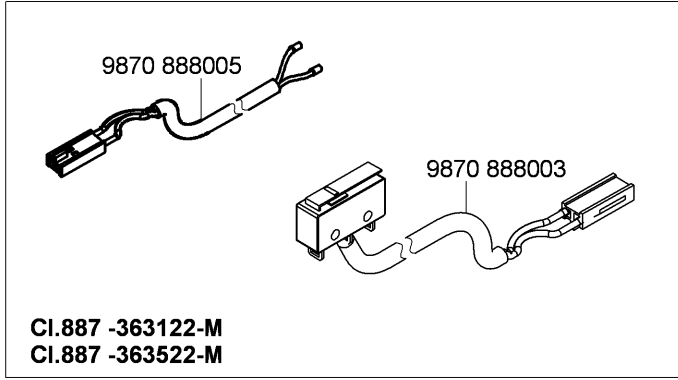
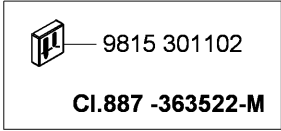
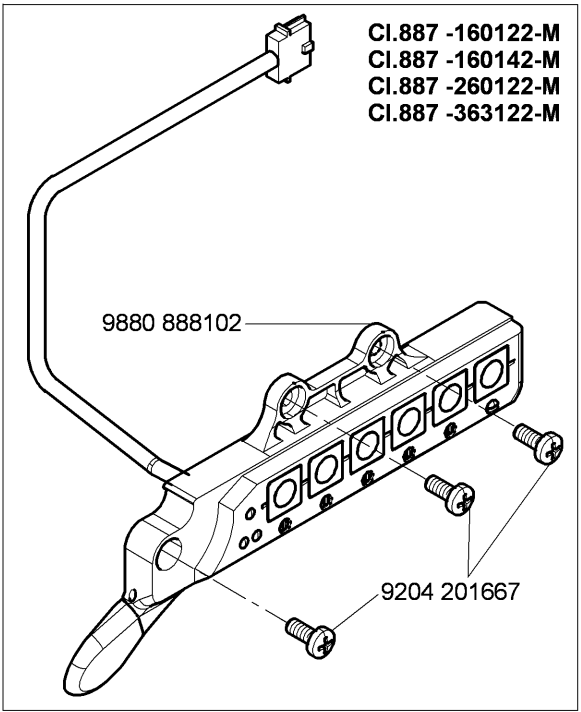
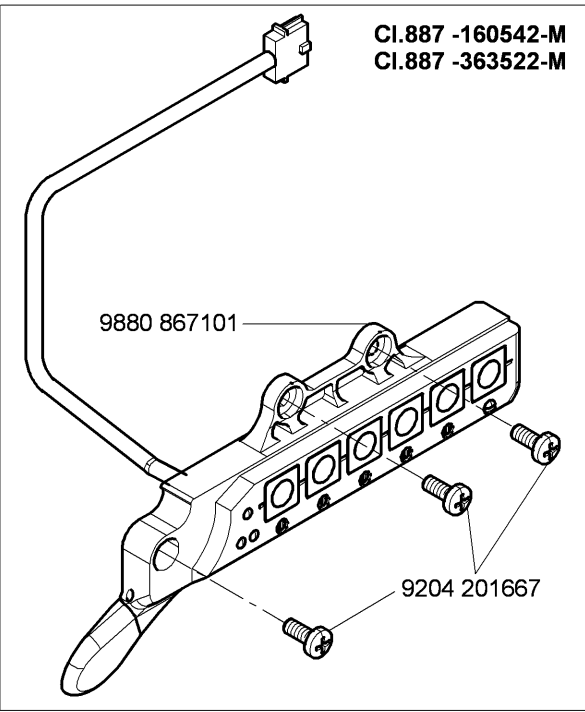

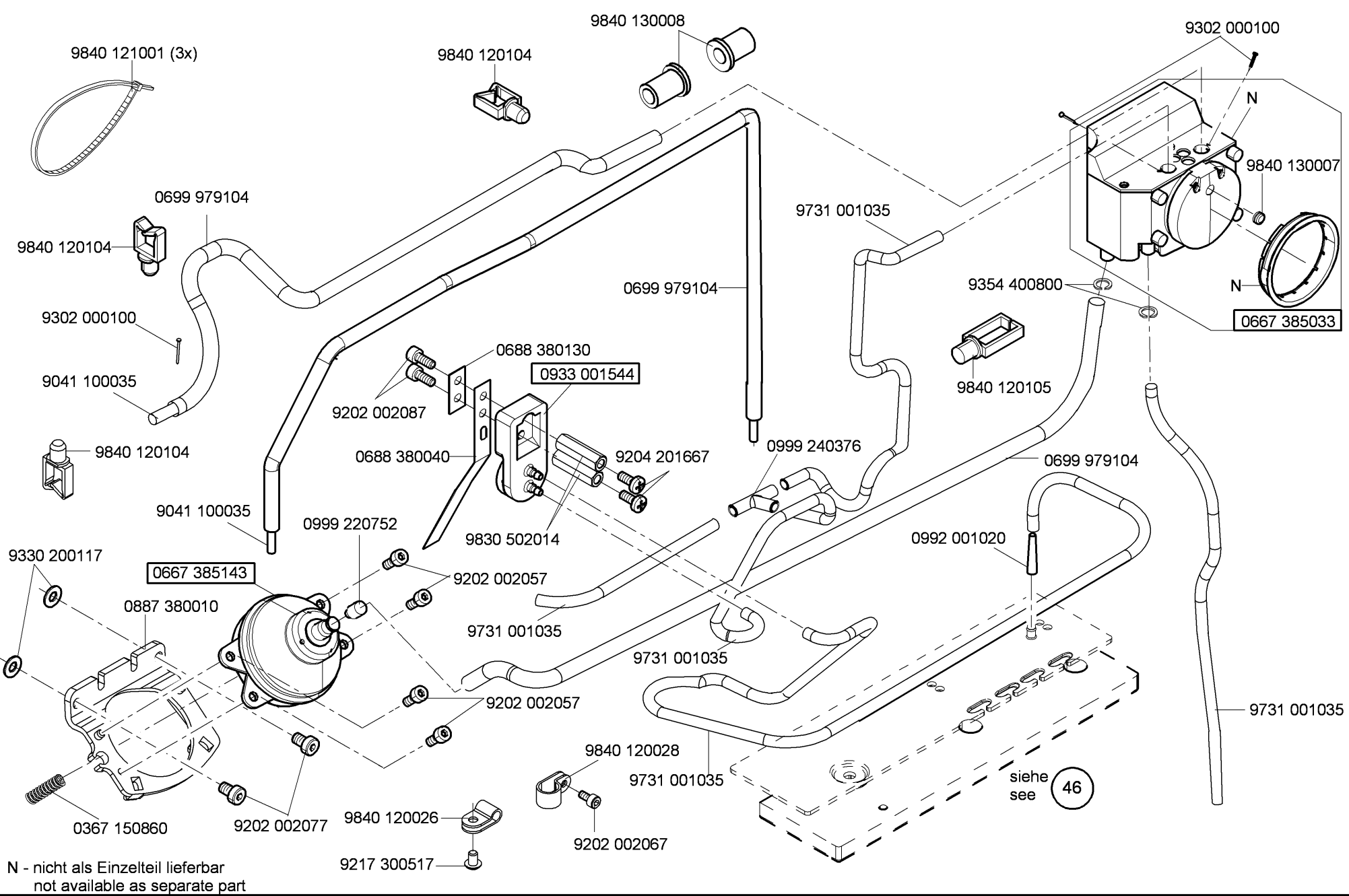

N - nicht als Einzelteil lieferbar  
not available as separate part

siehe  
see (46)



CI. 887 -160542-M  
CI. 887 -363522-M  
auf Wunsch  
on request

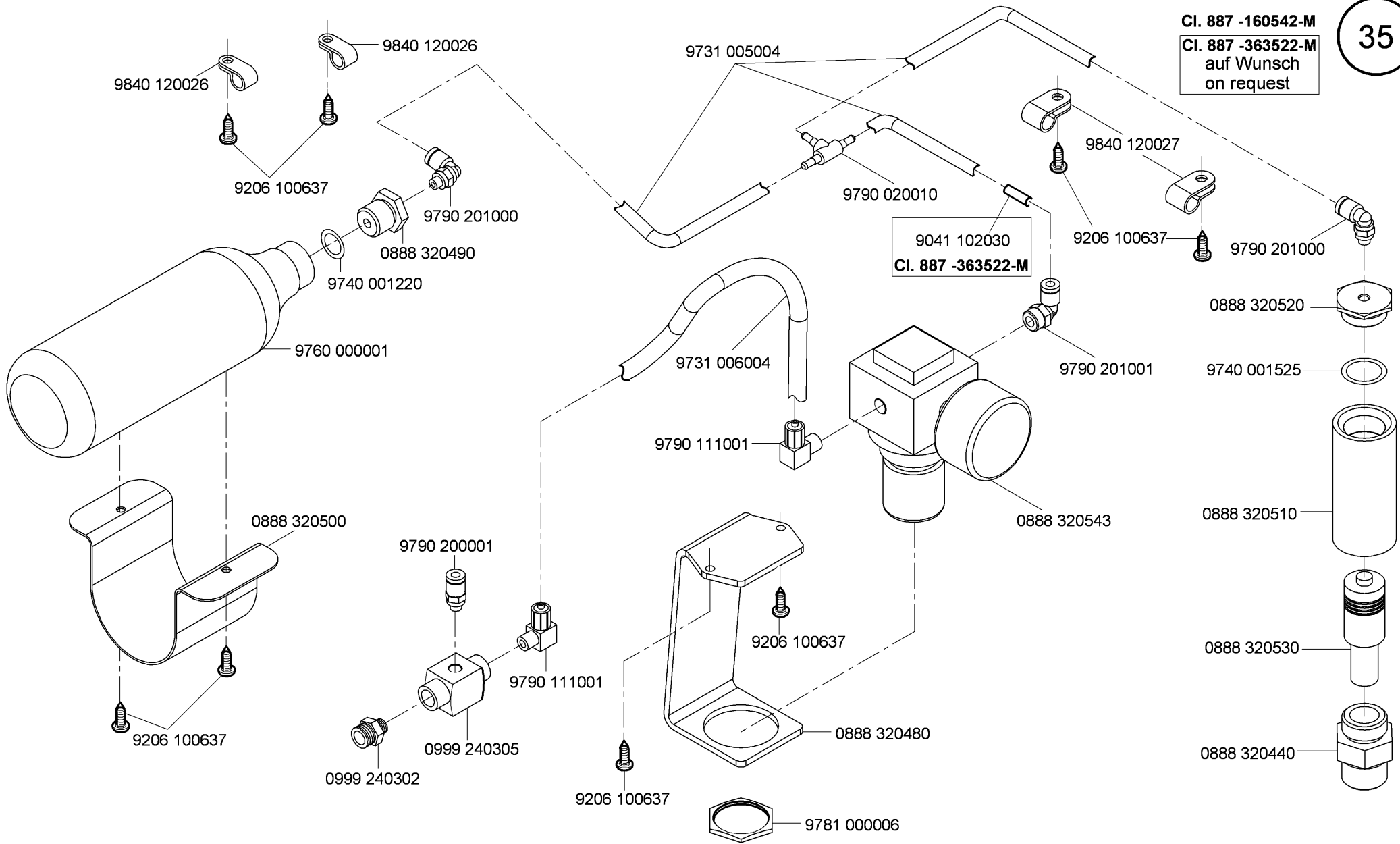

N - nicht als Einzelteil lieferbar  
not available as separate part

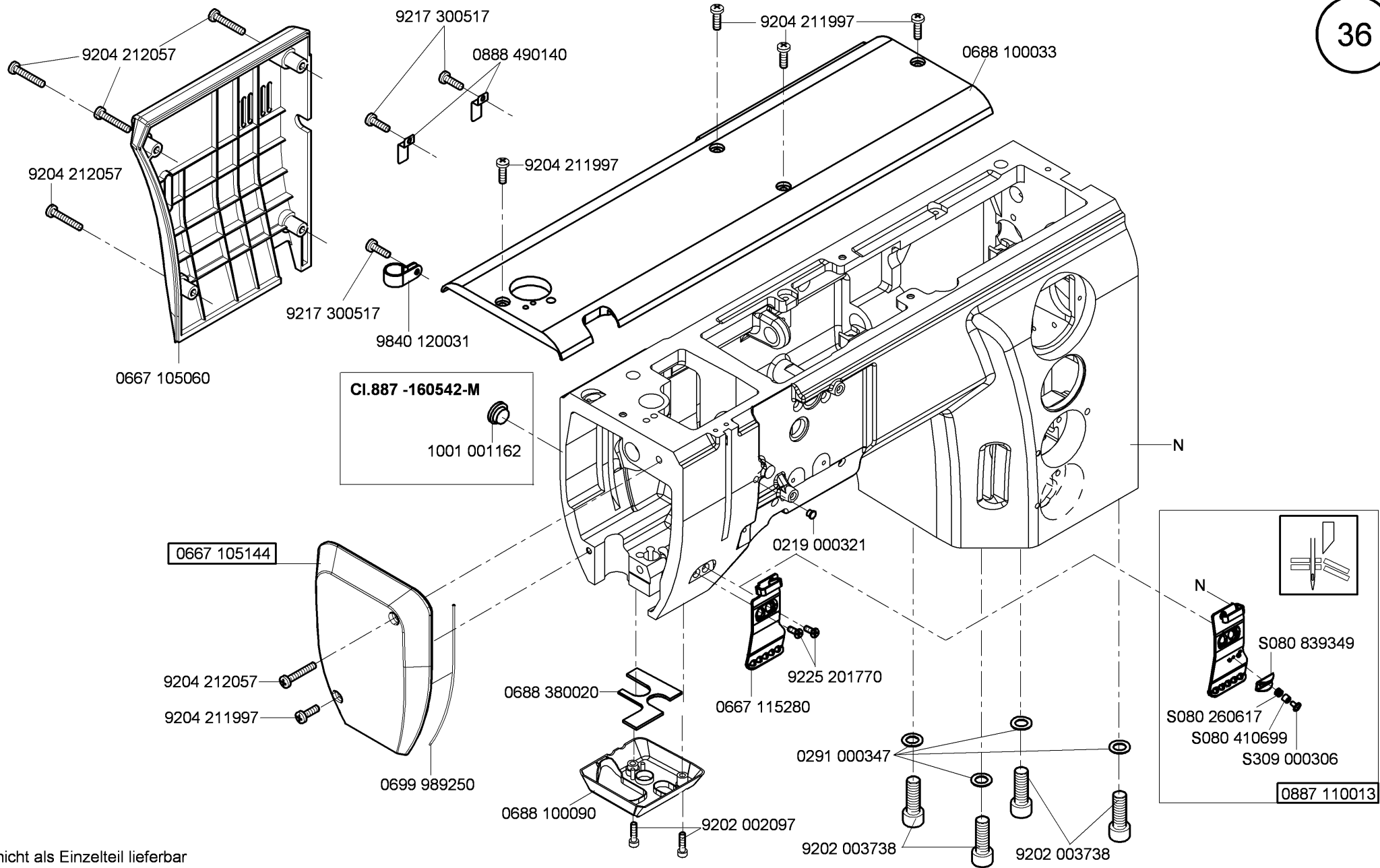

N - nicht als Einzelteil lieferbar  
not available as separate part

CI. 887 - M

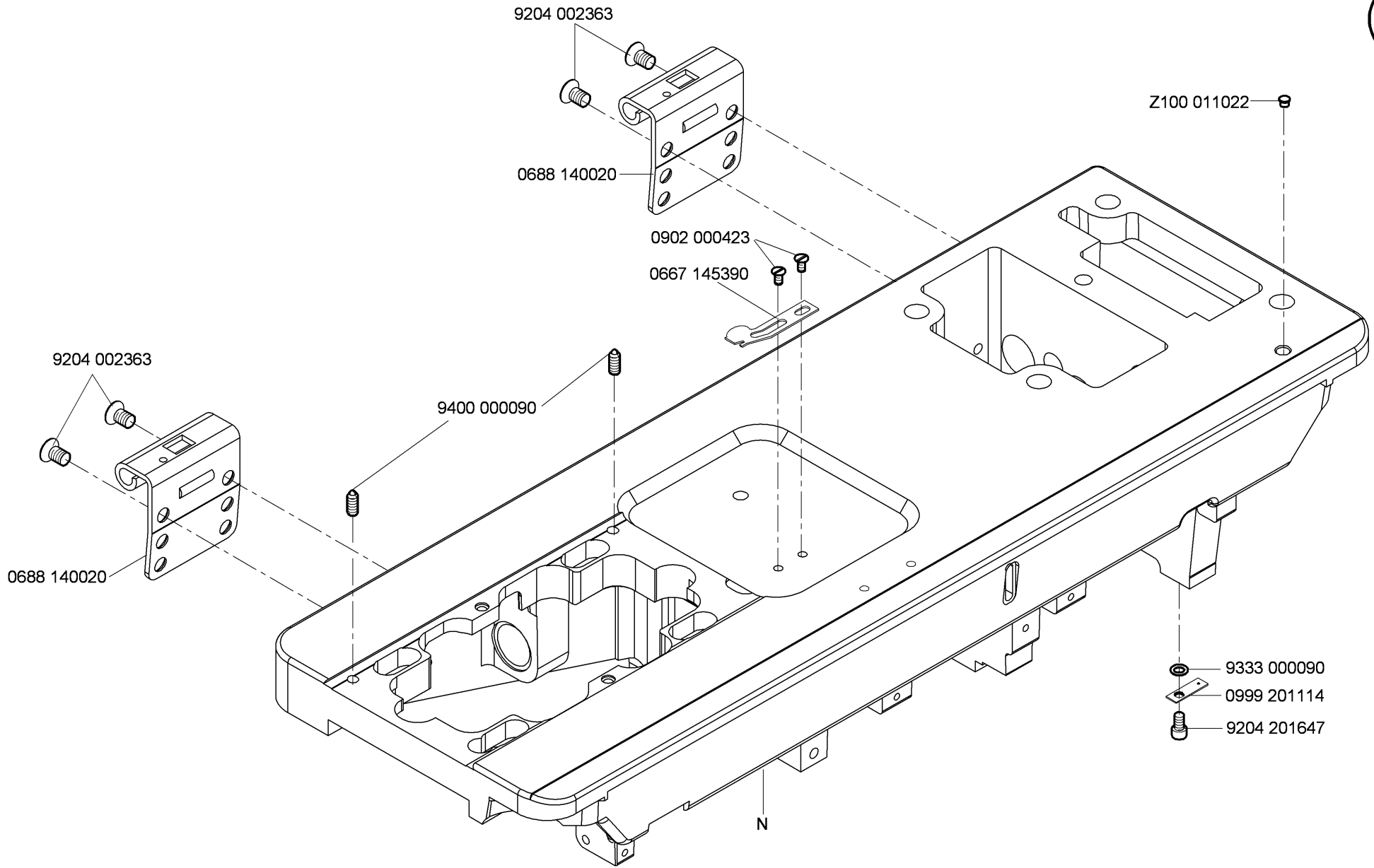

N - nicht als Einzelteil lieferbar  
not available as separate part

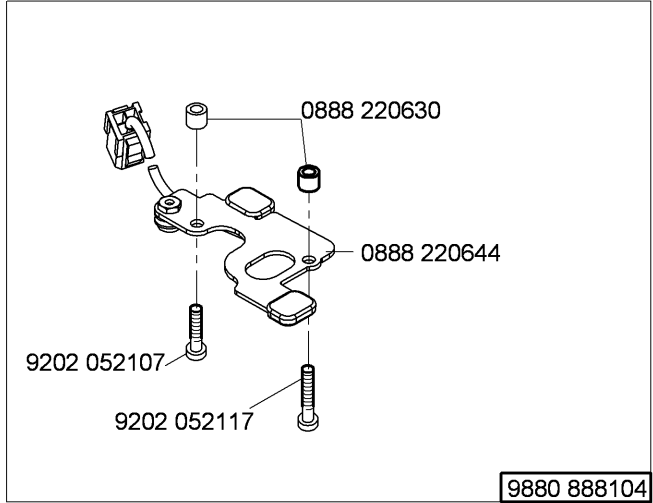
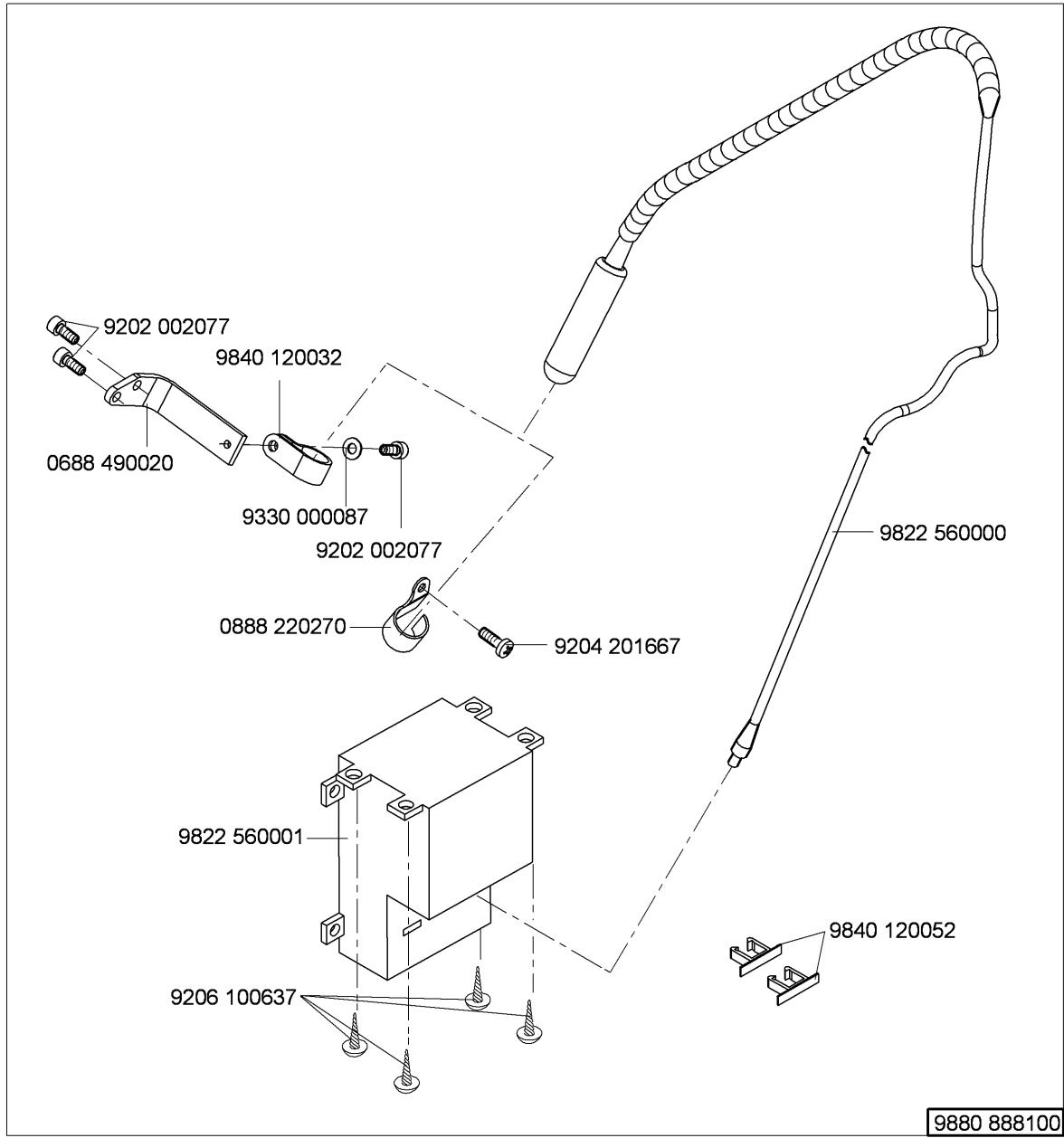

9880 887030  
ab/from 01/2016

39a

CI.887 -160020-M  
CI.887 -160040-M  
CI.887 -260020-M

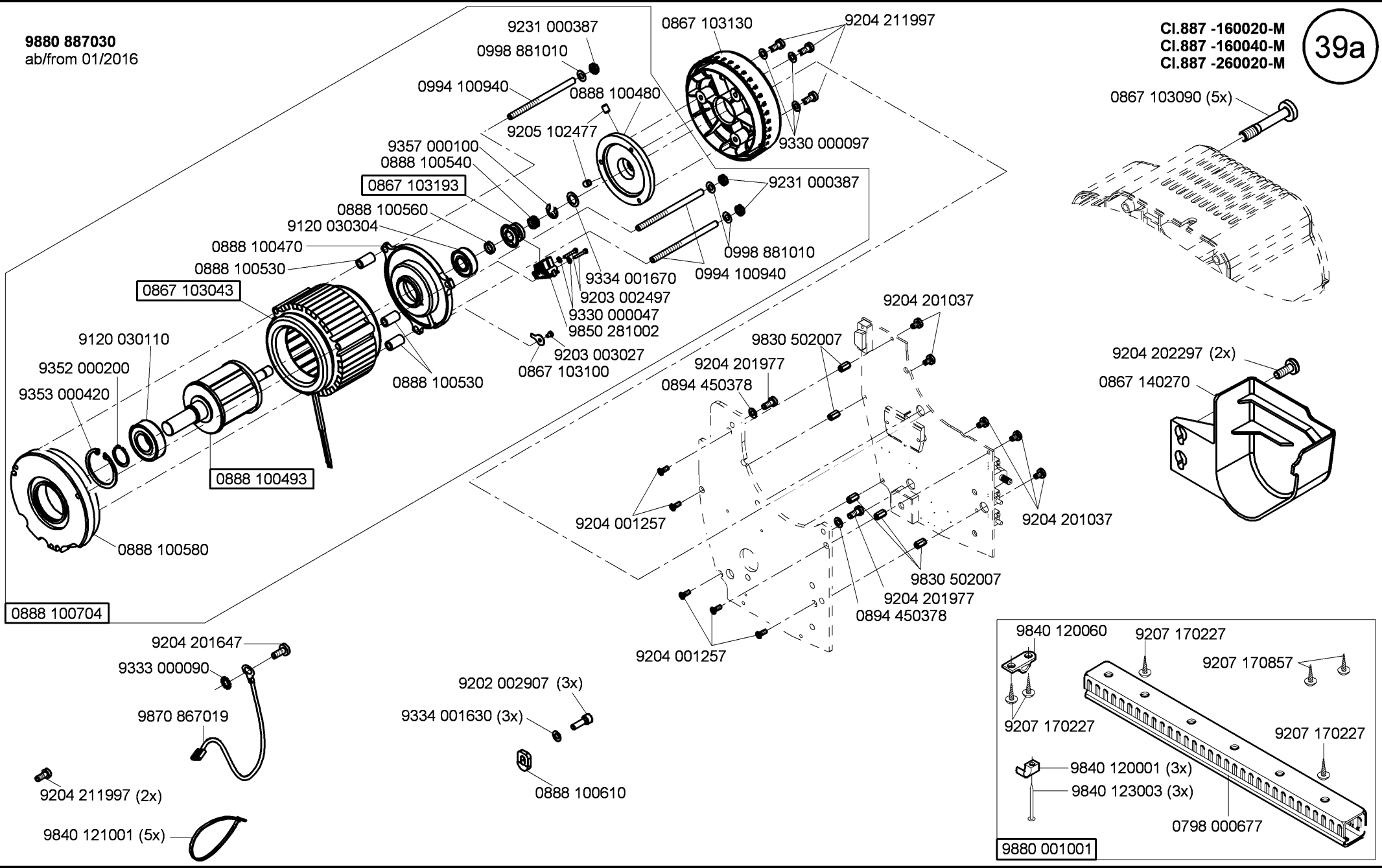

CI. 887 - M

Ausgabe/Edition 9.2016

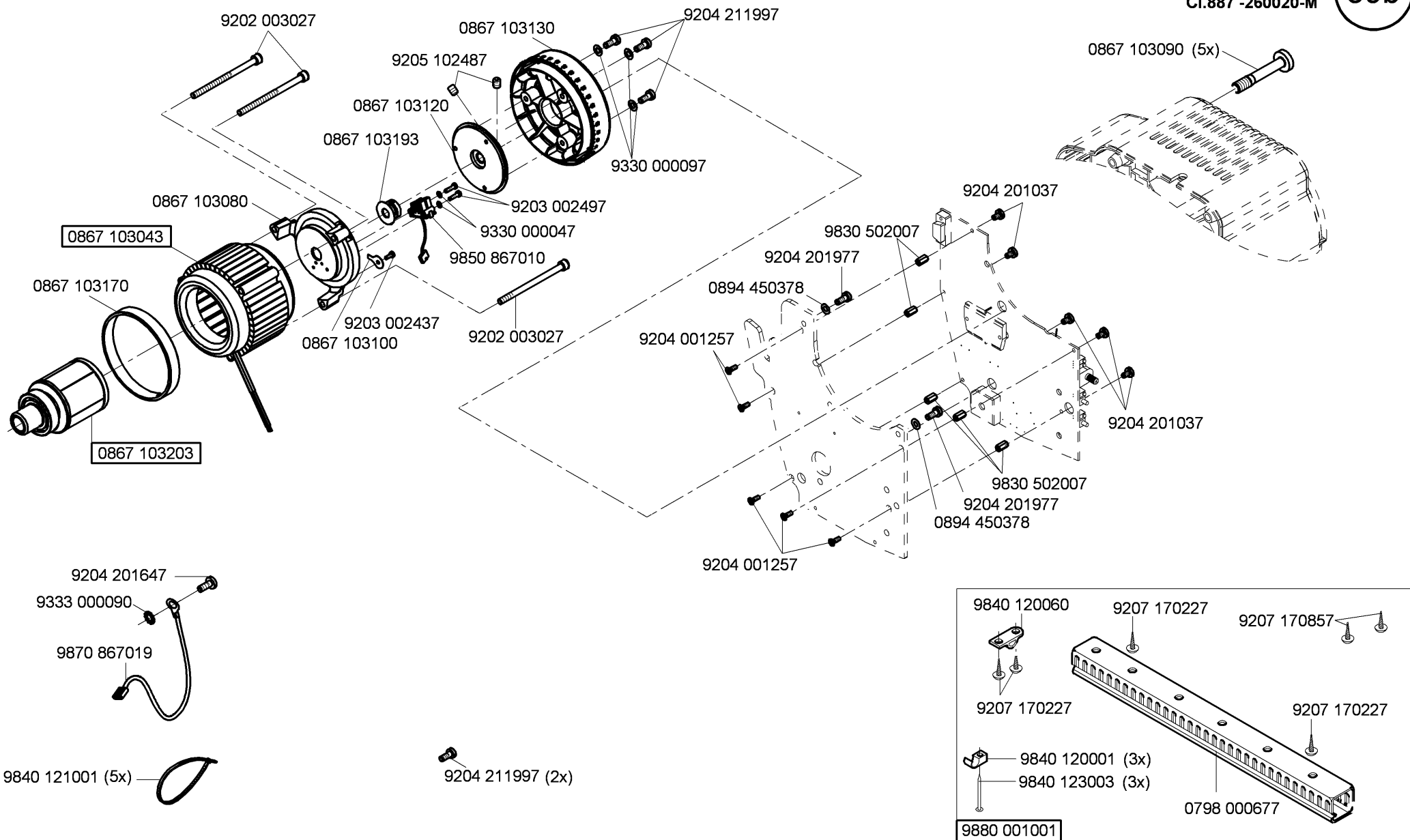

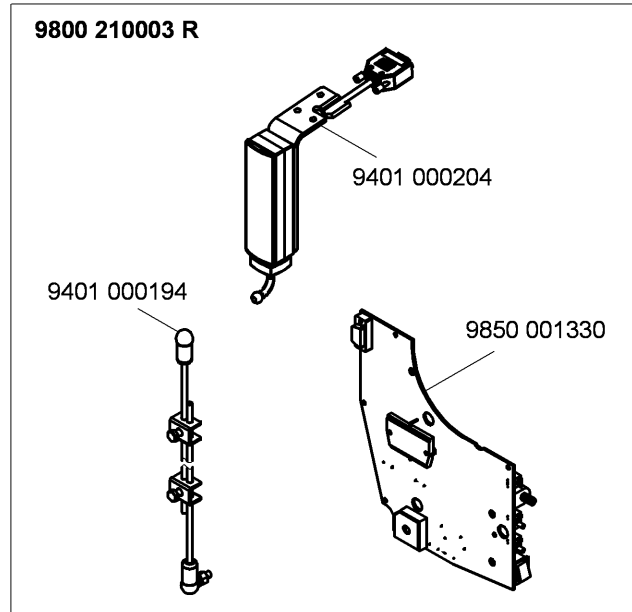
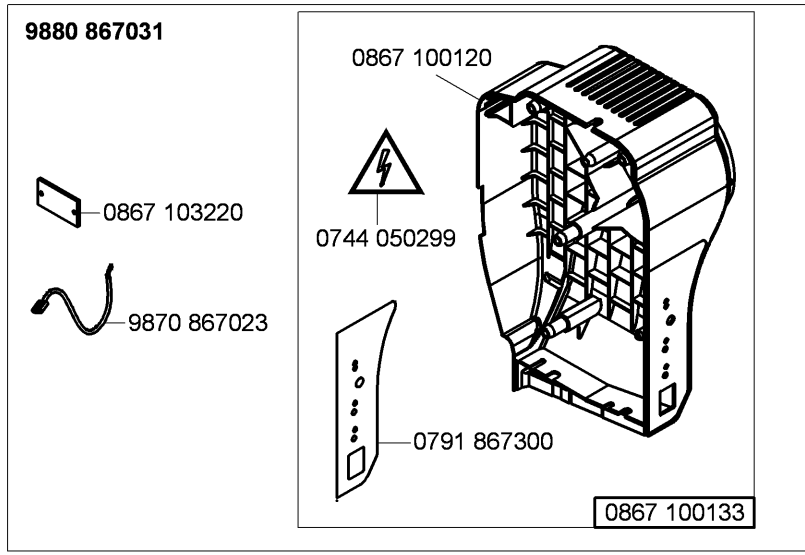
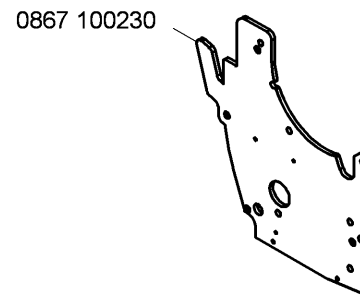
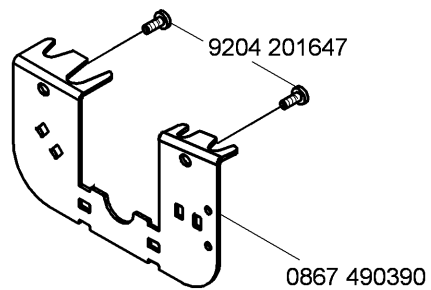

9880 888041  
ab/from 01/2016

CI.887 -160122-M  
CI.887 -160142-M  
CI.887 -167542-M  
CI.887 -260122-M  
CI.887 -363122-M  
CI.887 -353522-M

41a

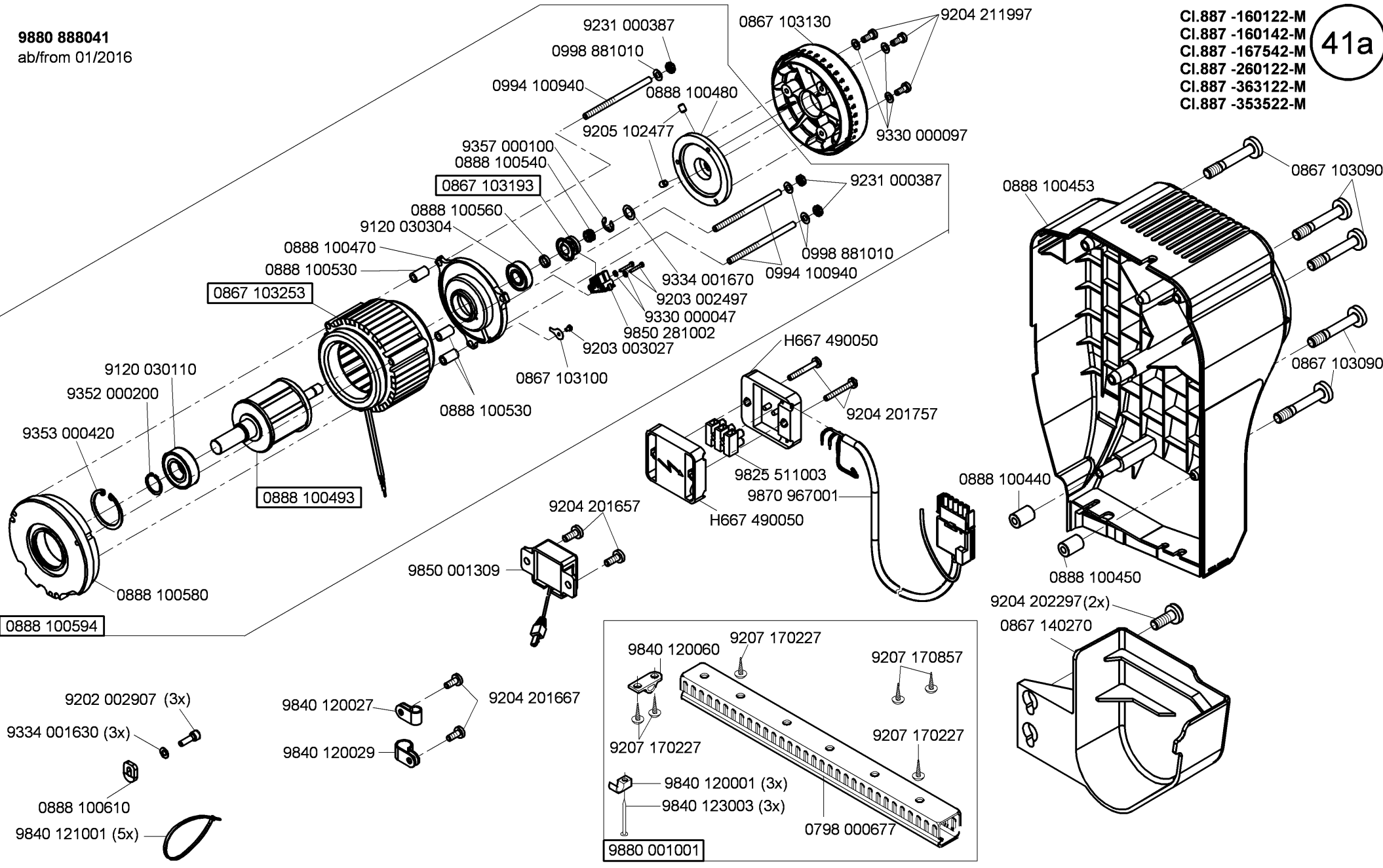



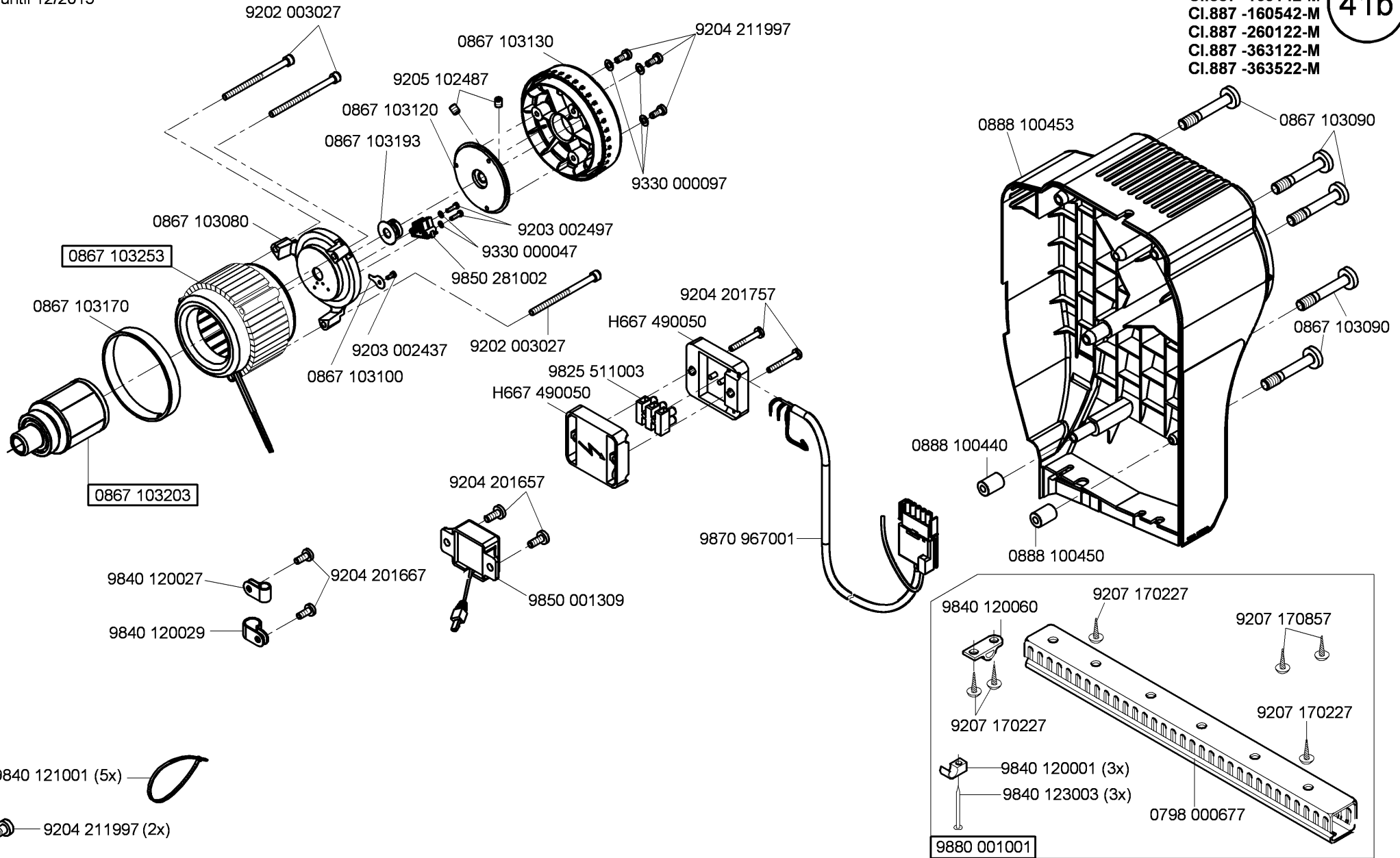

CI.887 -160122-M  
 CI.887 -160142-M  
 CI.887 -160542-M  
 CI.887 -260122-M  
 CI.887 -363122-M  
 CI.887 -363522-M

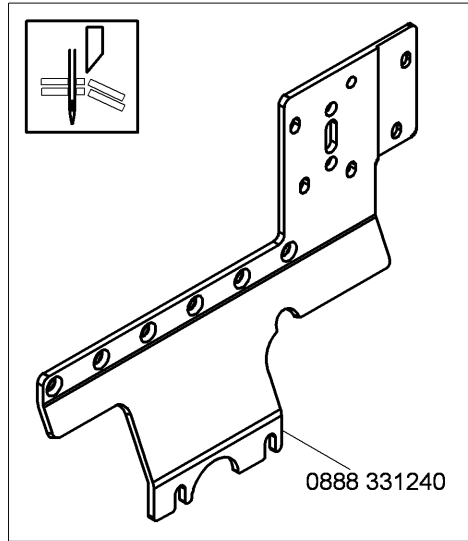
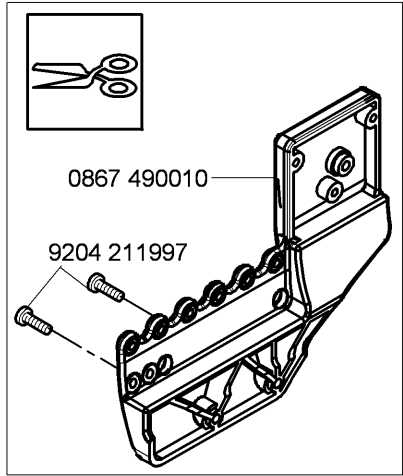
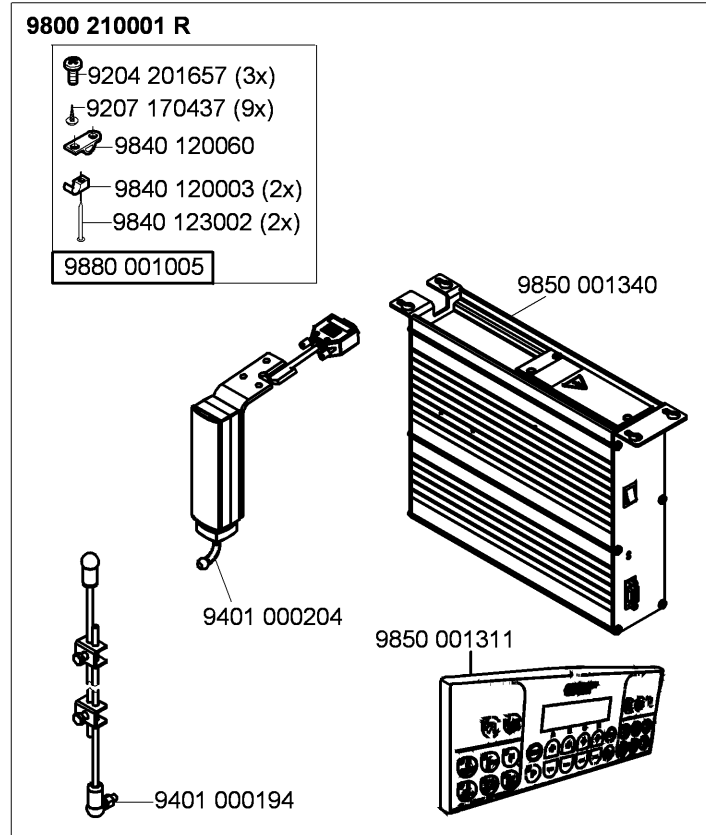
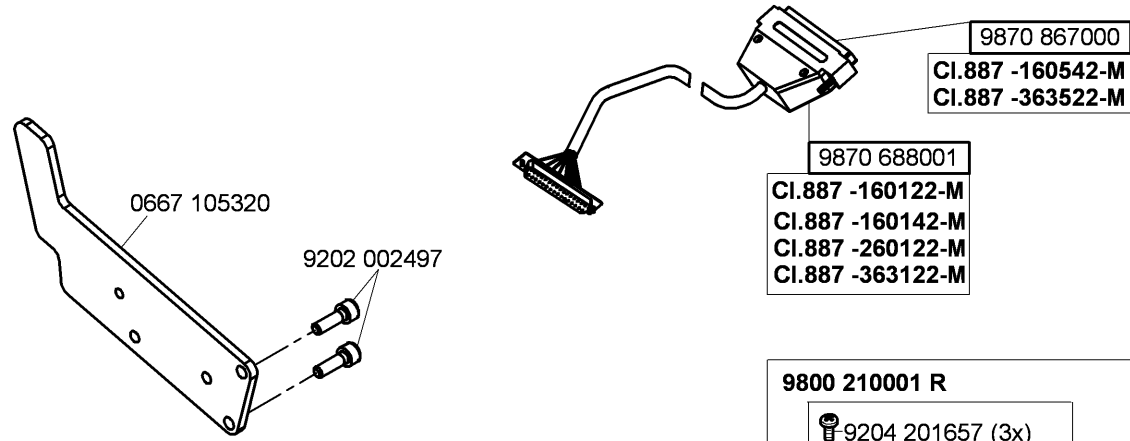

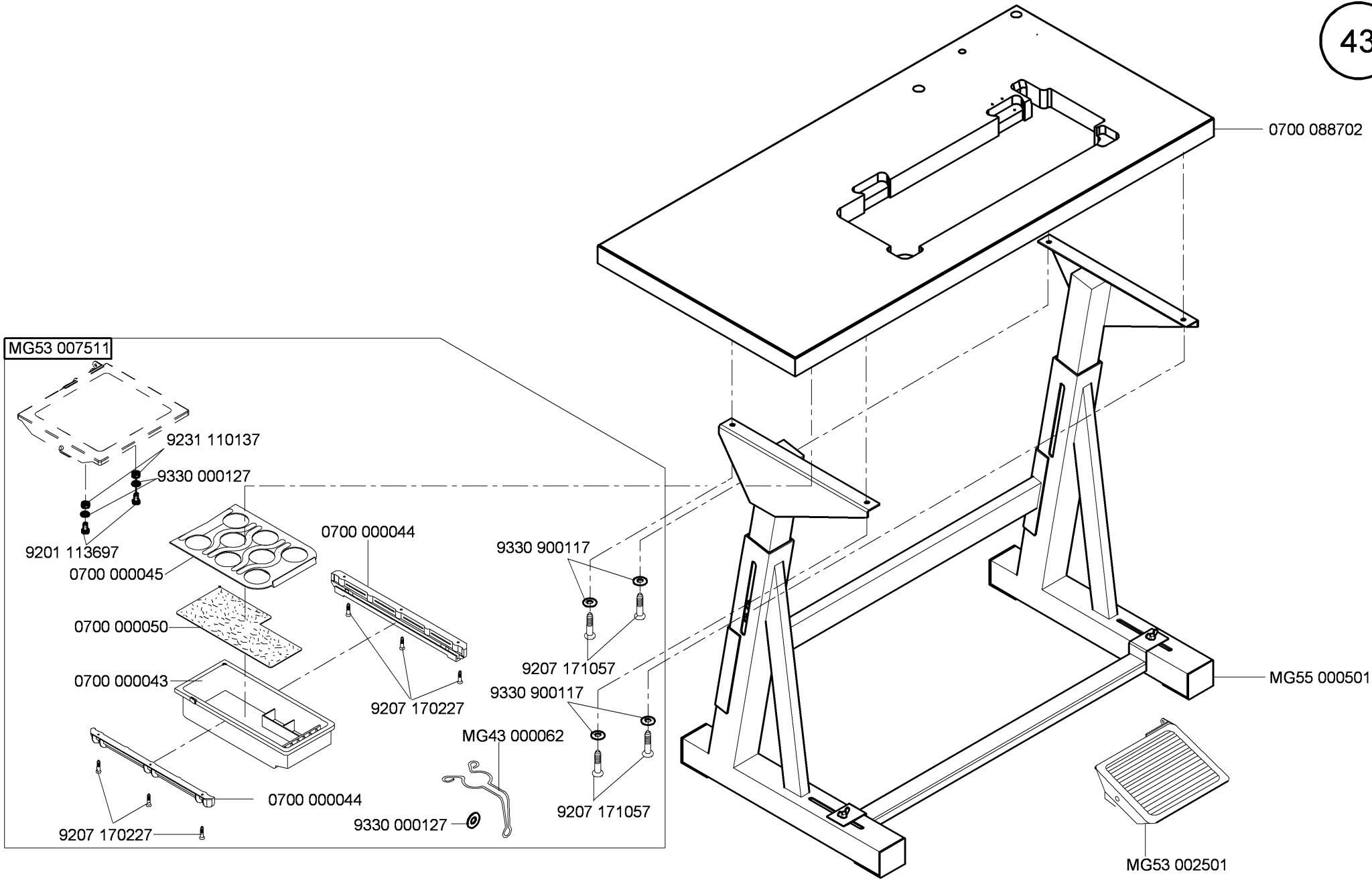

CI. 887 - M

auf Wunsch  
on request

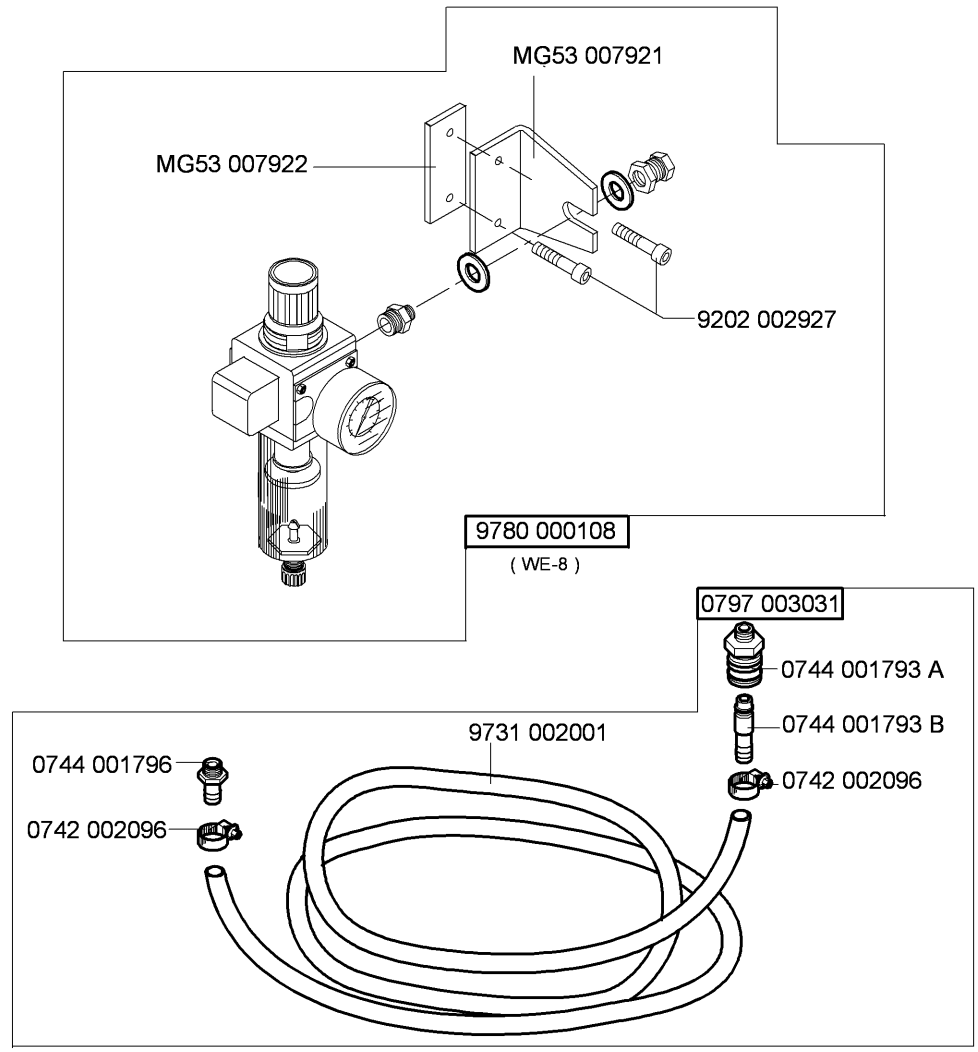

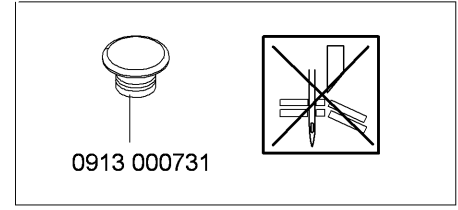
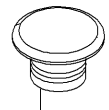
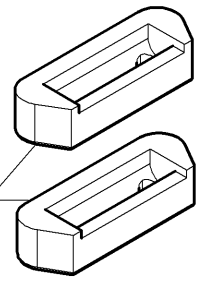
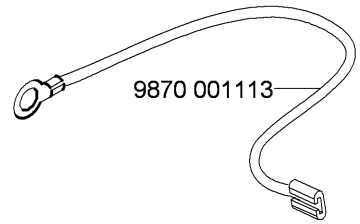
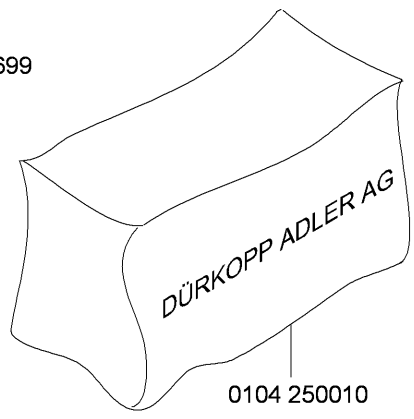
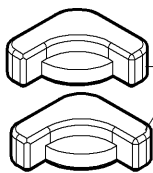
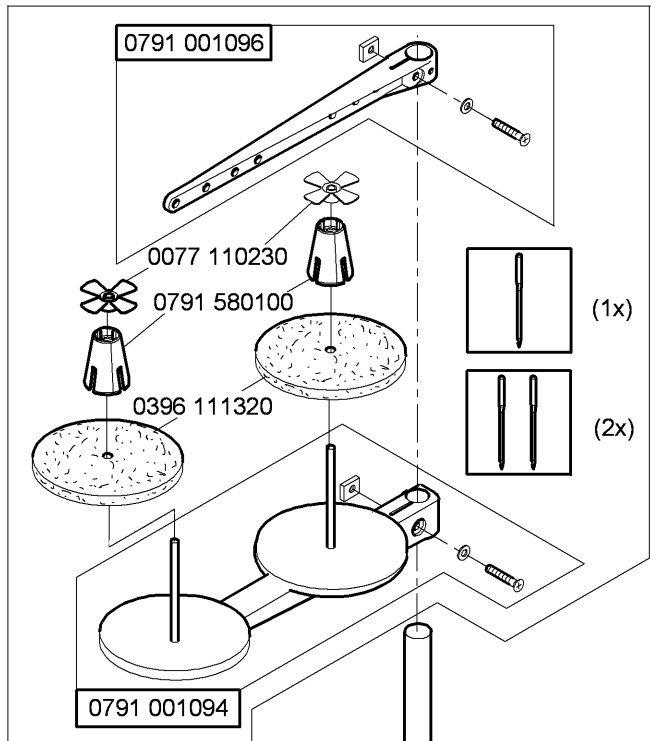

9081 200253

- 0791 001081
- 0995 340617
- 9330 000177
- 0995 340617

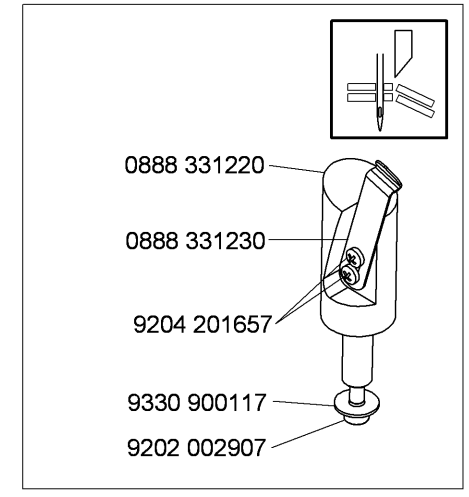
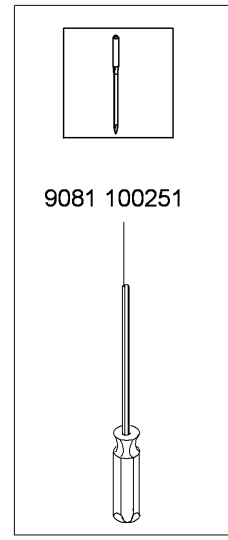
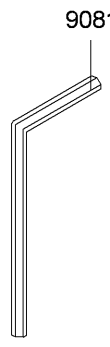
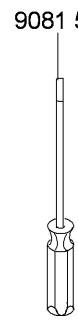
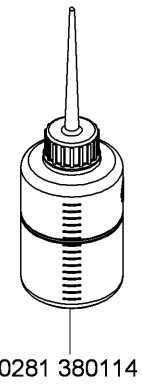

N - nicht als Einzelteil lieferbar  
not available as separate part

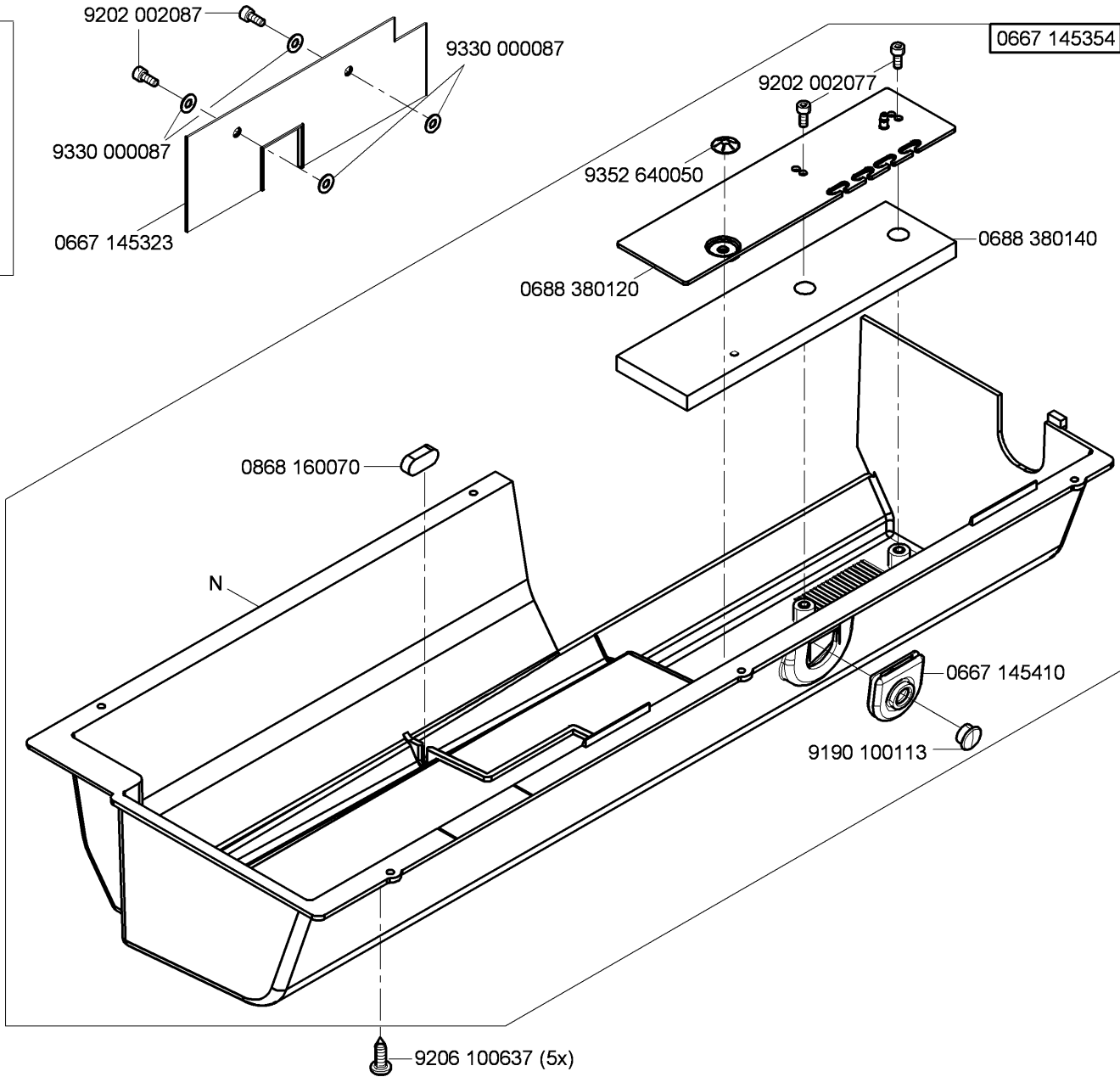
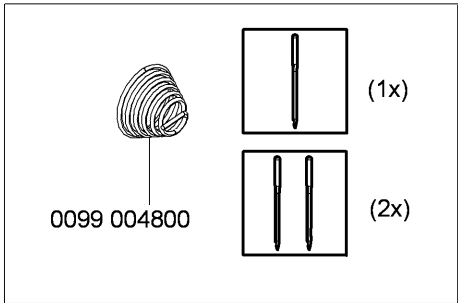

N - nicht als Einzelteil lieferbar  
not available as separate part

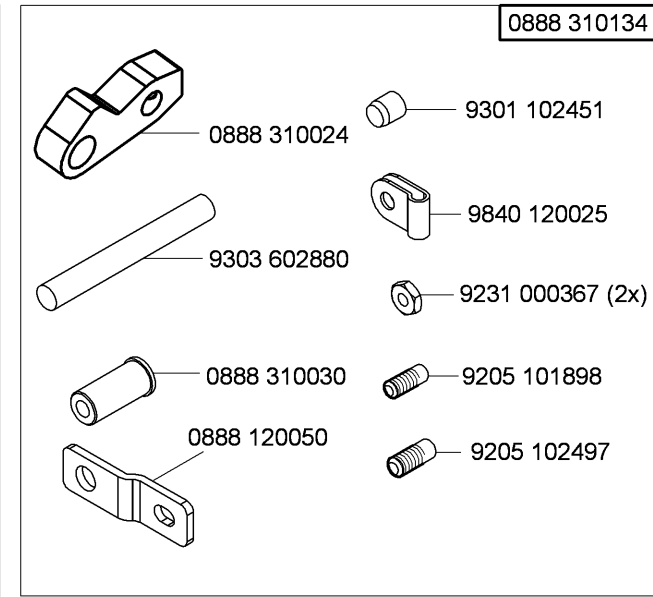
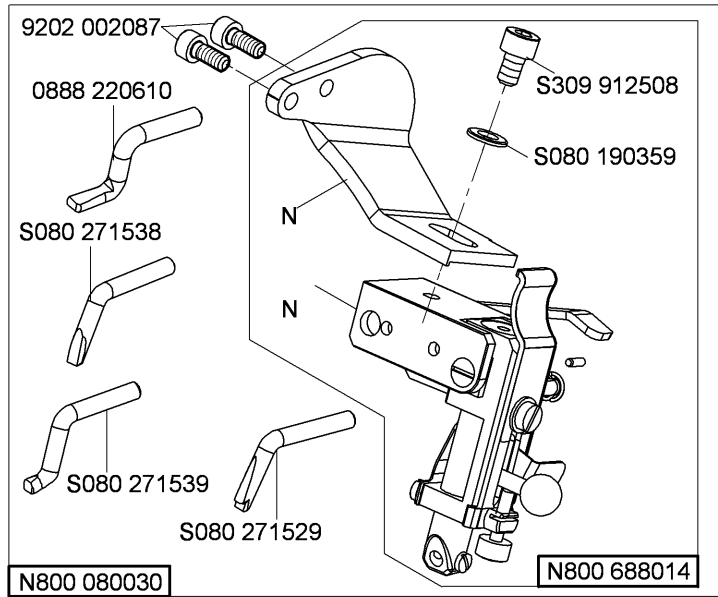
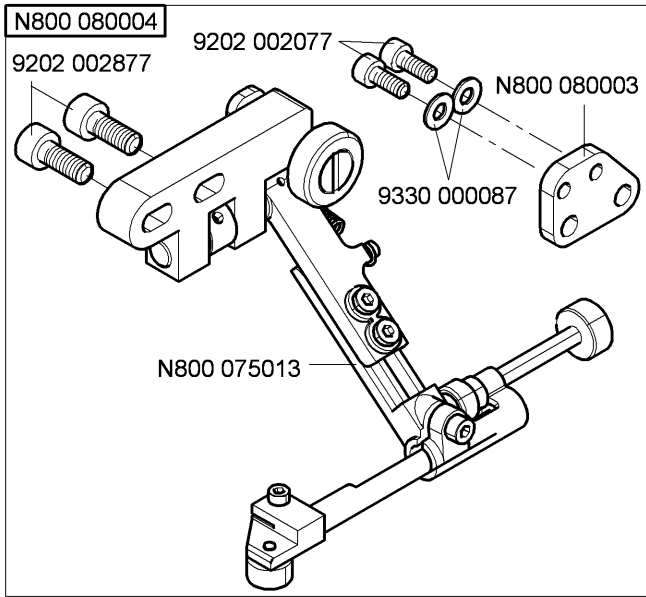
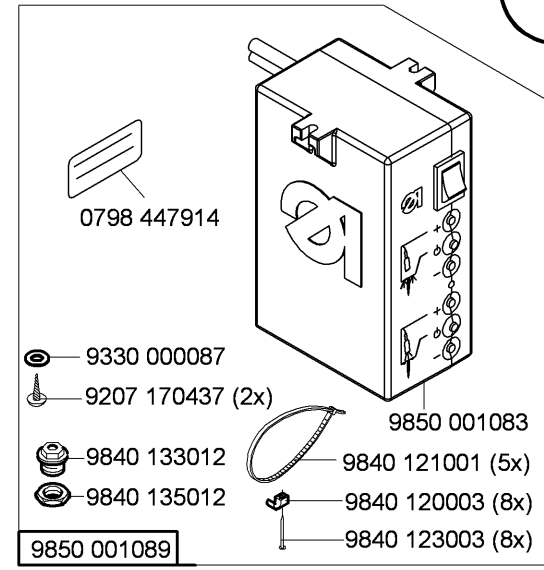
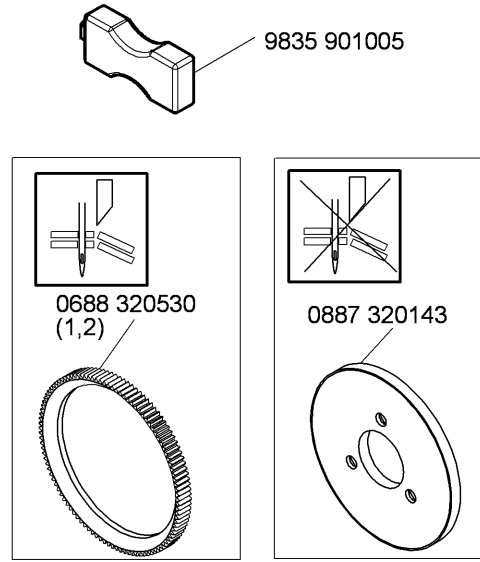
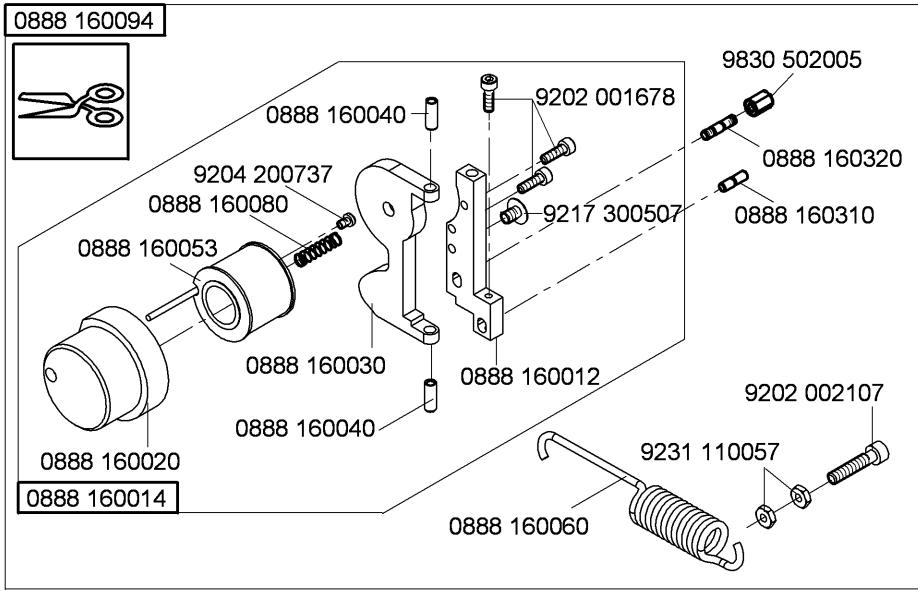

N - nicht als Einzelteil lieferbar  
not available as separate part

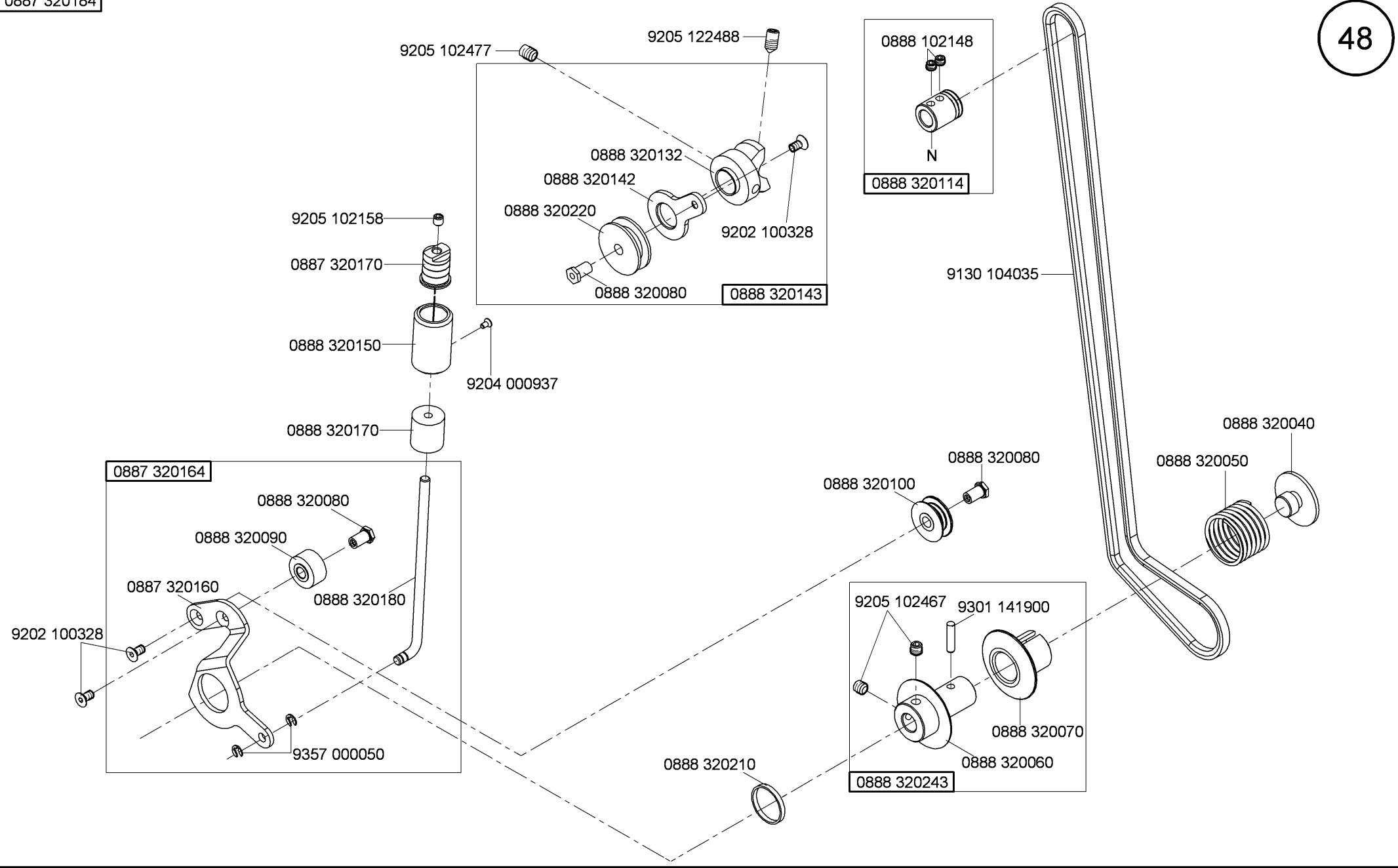



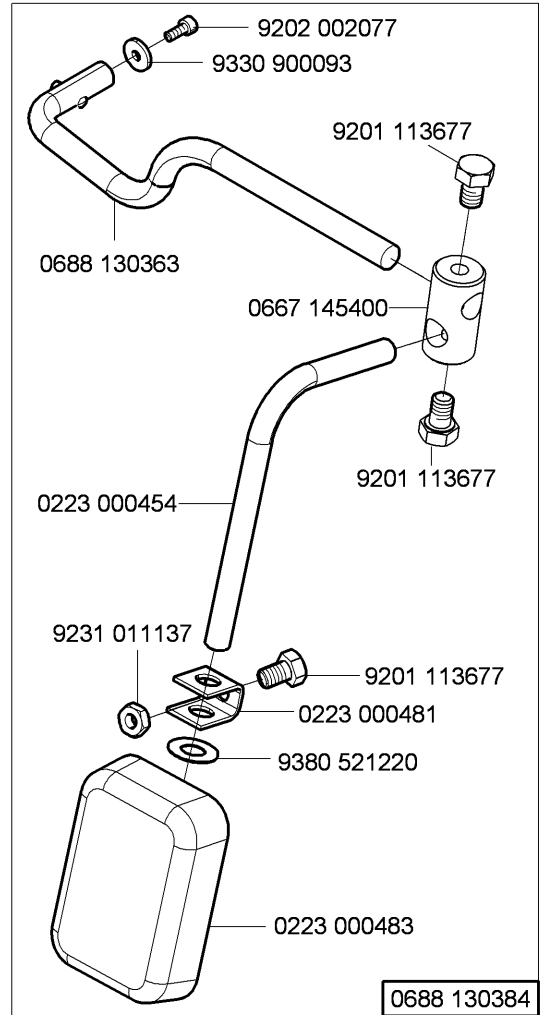
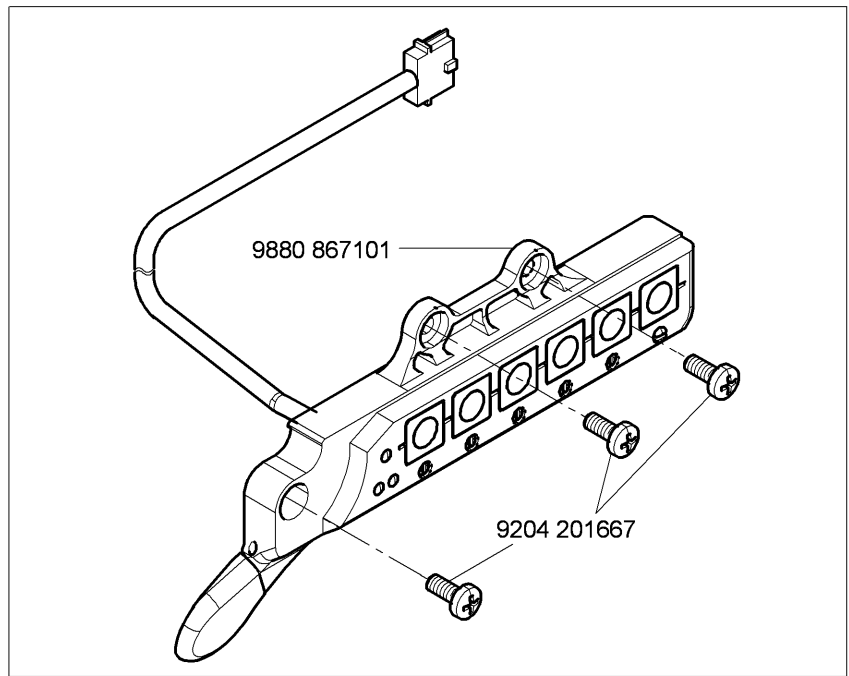
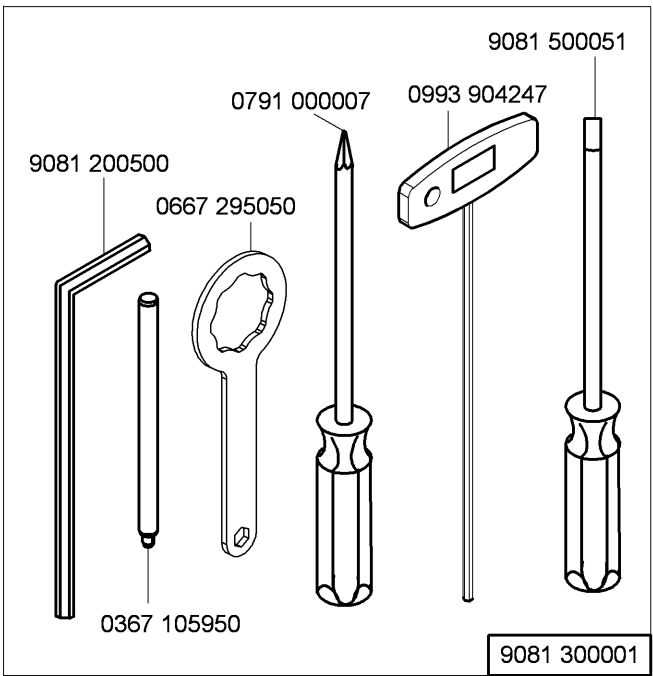
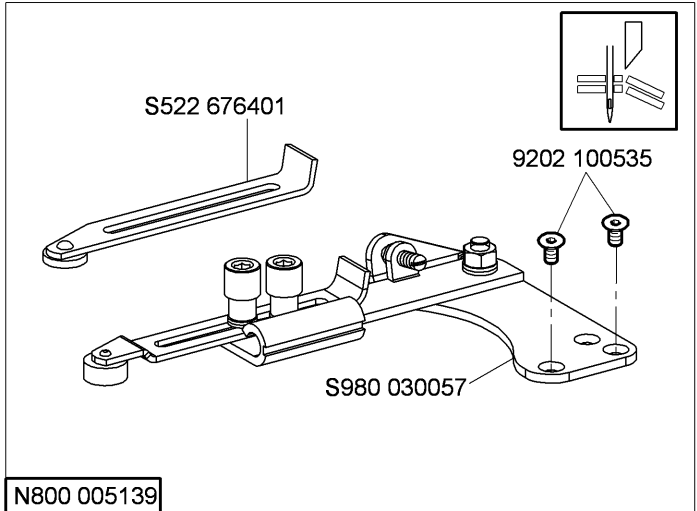
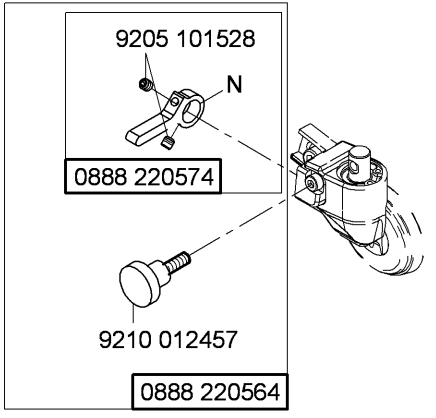

N - nicht als Einzelteil lieferbar  
not available as separate part

Ø 25 mm	1	
0888 220334	0888 220430	METAL
0888 220344	0888 220500	METAL
0888 220354	0888 220523	RUBBER

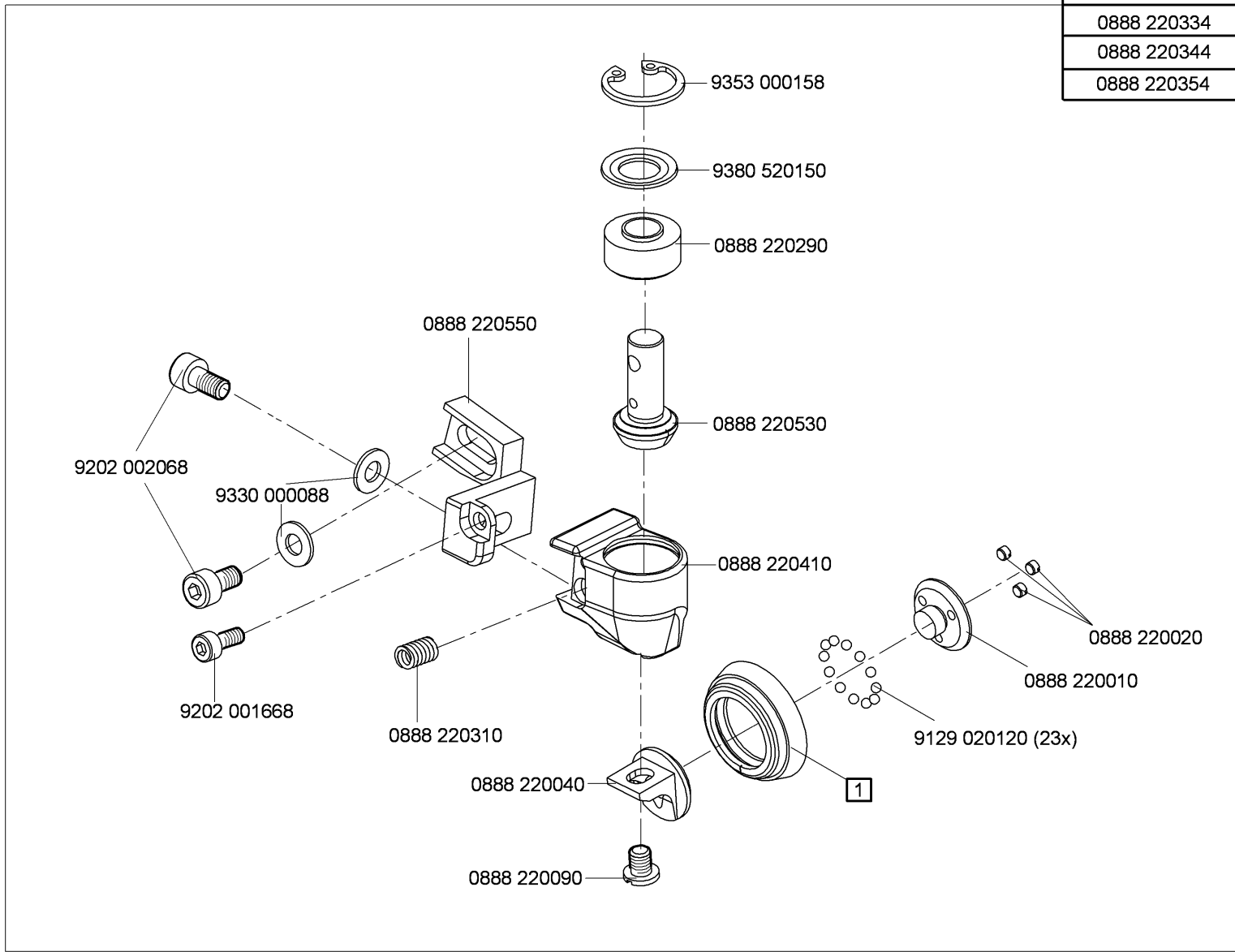

Ø 35 mm	1	
0888 220364	0888 220760	METAL
0888 220374	0888 220770	METAL
0888 220384	0888 220783	RUBBER

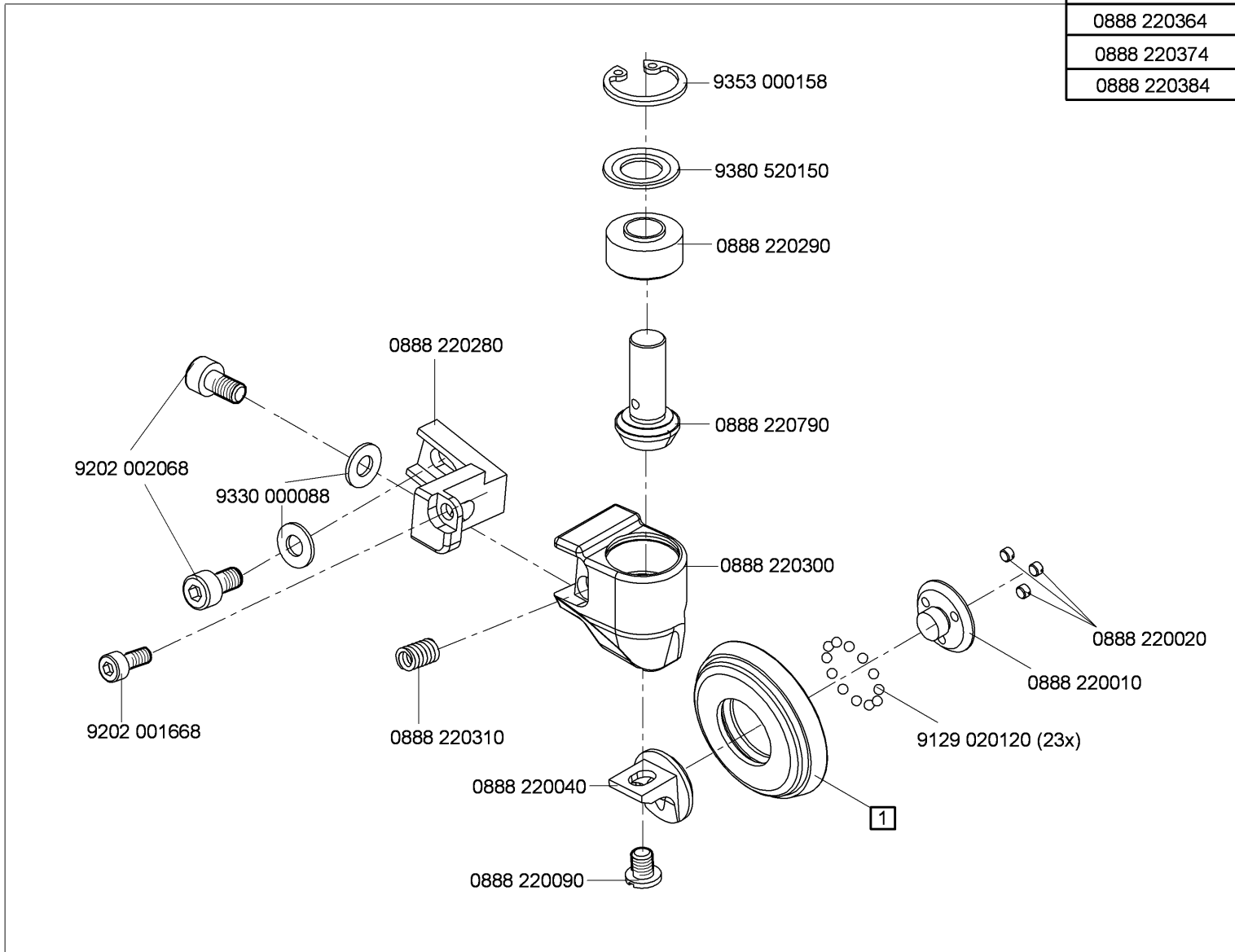

Ø 45 mm	<b>1</b>	mm
0888 220394	0888 220450	3,8
0888 220404	0888 220460	2

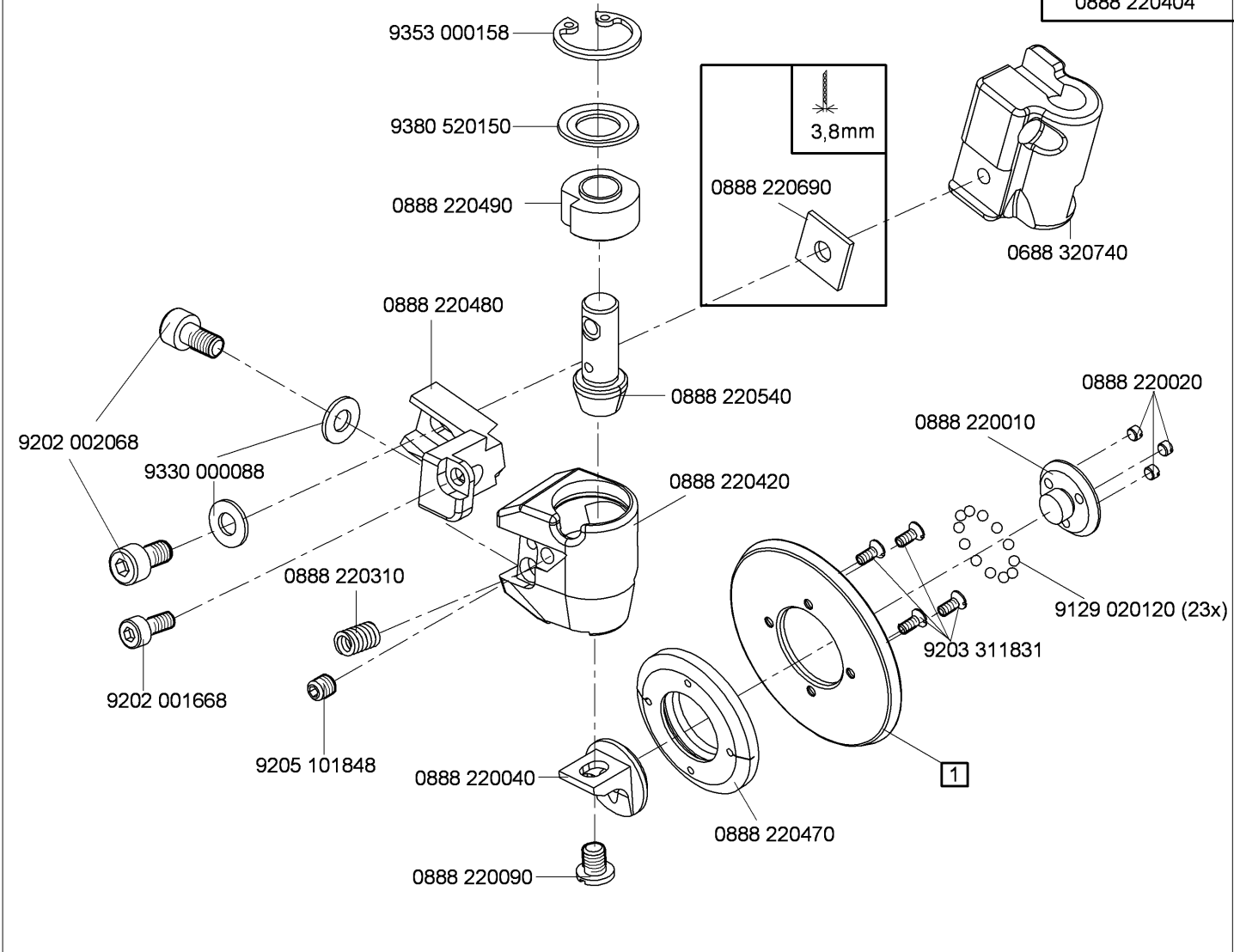

0867 592184

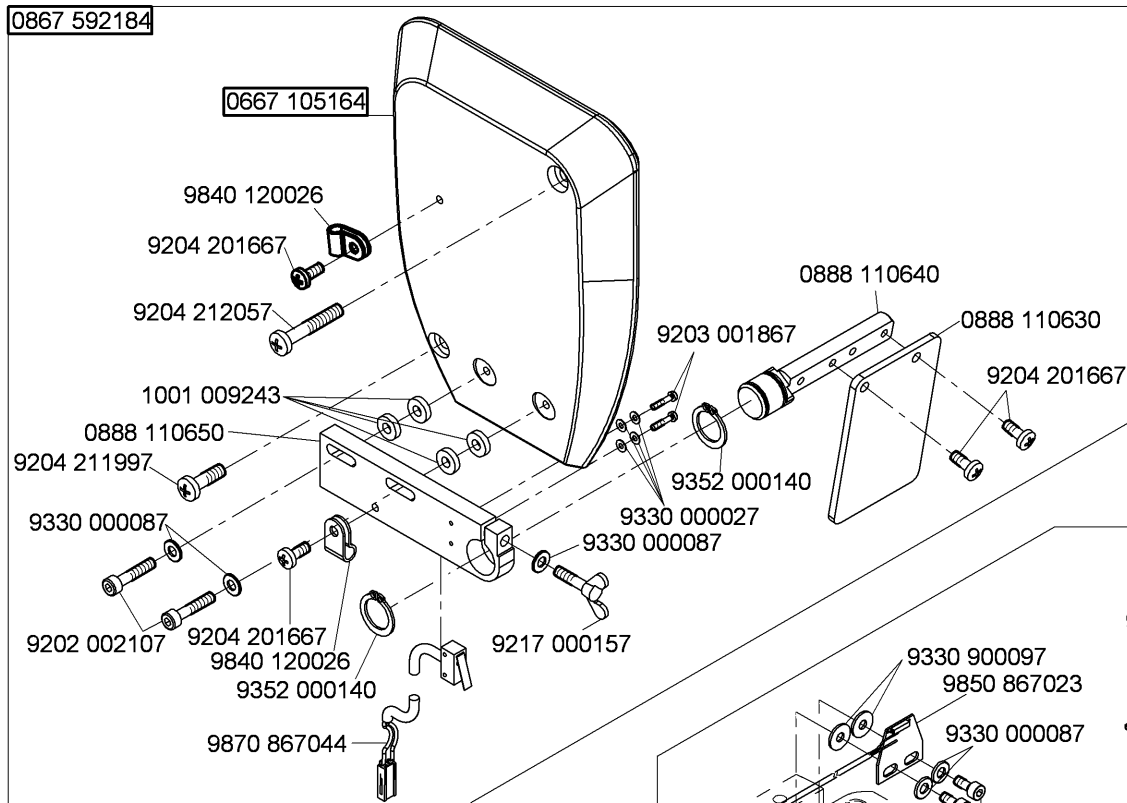

0867 590034

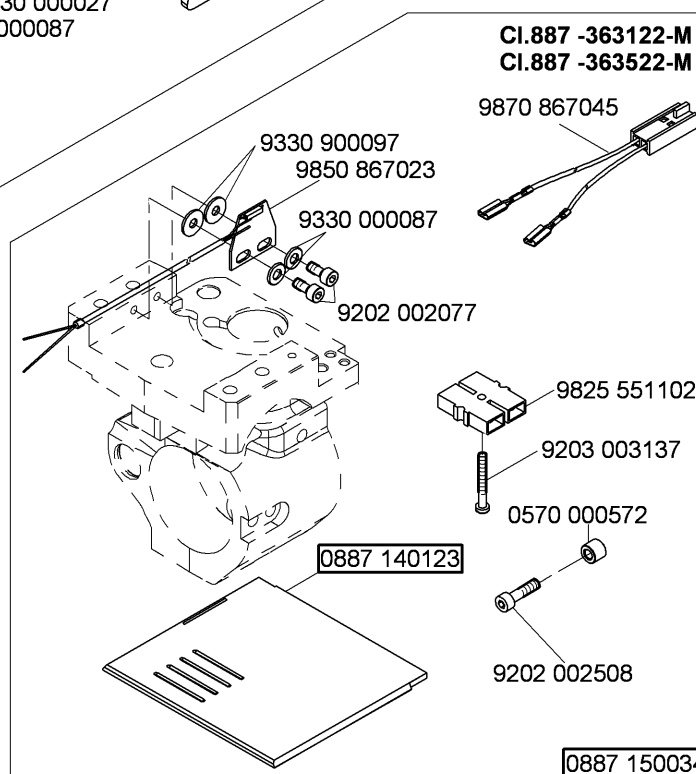
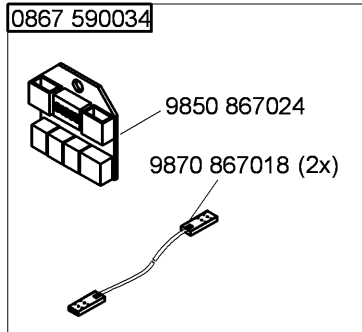

0887 150024

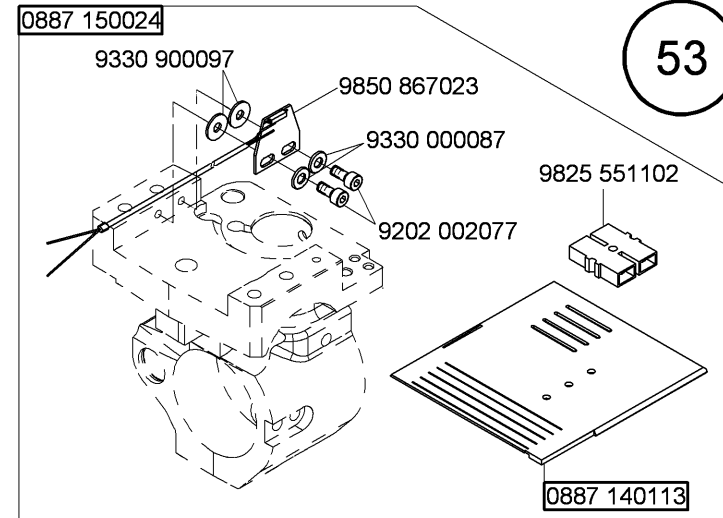

0887 150014

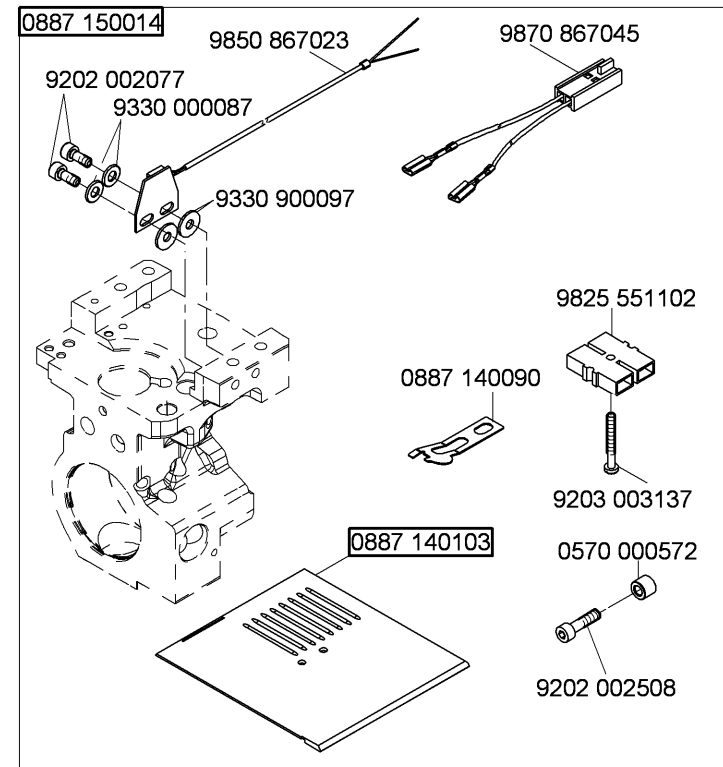

Teile-Nr./Part-No.	Tafel/Table	Teile-Nr./Part-No.	Tafel/Table	Teile-Nr./Part-No.	Tafel/Table	Teile-Nr./Part-No.	Tafel/Table	Teile-Nr./Part-No.	Tafel/Table
0037 001280	24,25,26,27,28	0367 145110	11	0667 115170	24,25,26,27,28	0667 135040	12	0667 155540	17,18
0053 000350	24,27	0367 150860	34	0667 115180	24,25,26,28	0667 135073	12	0667 155550	17,18
0061 001050	24,25,26,27,28	0367 165080	6	0667 115203	26,28	0667 135094	11	0667 155614	16
0069 002540	20,21,22	0367 165120	6	0667 115210	26,28	0667 135103	11	0667 155634	16
0077 110230	45	0367 315223	8	0667 115250	24,25,26,27,28	0667 135124	11	0667 155893	17,18
0099 004800	46	0396 111320	45	0667 115280	36	0667 135150	12	0667 155900	17,18
0099 004910	24,25,26,27,28	0467 110220	24,25,26,27,28	0667 115290	24,25,26,27,28	0667 135190	5	0667 155940	2
0104 250010	45	0467 150040	15	0667 115310	24,25,26,27,28	0667 135204	14	0667 155950	17
0211 000648	17,18	0467 150130	15	0667 115320	3	0667 145044	2	0667 156180	16
0211 000699	45	0480 350200	19	0667 115344	28	0667 145074	2	0667 156190	15
0216 000591	23	0480 350214	19	0667 115354	26	0667 145264	2	0667 156210	16
0219 000321	36	0491 030652	31	0667 115360	24,25,27,28	0667 145303	2	0667 156320	15
0223 000454	49	0556 000821 A	29,30	0667 115420	24,27	0667 145323	46	0667 156330	16
0223 000481	49	0556 000895	22	0667 115430	24,27	0667 145354	46	0667 160170	29,30
0223 000483	49	0570 000572	53	0667 115440	26	0667 145390	37	0667 160350	29,30
0244 000403	23	0570 001847	32	0667 115444	26	0667 145400	49	0667 165130	6
0244 000700	8	0667 100050	3	0667 115490	24	0667 145410	46	0667 165133	6
0244 014619	20,21	0667 105060	36	0667 115514	24	0667 145464	2	0667 165154	6
0245 001660 A	15	0667 105144	36	0667 115520	24,25,26,27,28	0667 150830	16	0667 165210	31
0265 000911	24,25,26,27,28	0667 105164	53	0667 115530	24,25,27,28	0667 150840	16	0667 165220	31
0271 000275	23	0667 105320	42	0667 115544	25	0667 150850	16	0667 165234	30
0271 001639	22,29,30	0667 115070	24,25,27,28	0667 115570	27,28	0667 155100	17,18	0667 165243	29,30
0272 070202	20,21	0667 115080	24,25,27,28	0667 115580	27,28	0667 155114	17	0667 165250	29,30
0281 380114	45	0667 115090	24,25,27,28	0667 115590	24,25,26,27,28	0667 155390	17,18	0667 165260	29,30
0291 000334	29,30	0667 115094	27	0667 115600	24,25,26	0667 155403	17,18	0667 165273	29,30
0291 000347	36	0667 115110	27	0667 115610	24,25,26,27,28	0667 155424	17,18	0667 165284	29,30
0291 000598	20	0667 115120	24,27	0667 115620	24,25,26	0667 155440	17	0667 165290	29,30
0367 105950	45,49	0667 115130	24,27	0667 115630	24,25,26,27,28	0667 155450	18	0667 165550	6
0367 110340	24,25,26,27,28	0667 115134	24,27	0667 115640	24,25,26,27,28	0667 155460	17,18	0667 165570	31
0367 110360	24,25,26,27,28	0667 115140	24,27	0667 125160	3	0667 155474	17	0667 170120	23
0367 120100	3	0667 115150	24,27	0667 125243	3	0667 155490	17,18	0667 175030	23
0367 135200	14	0667 115160	24,27	0667 135033	11	0667 155530	17,18	0667 175034	23

Teile-Nr./Part-No.	Tafel/Table	Teile-Nr./Part-No.	Tafel/Table	Teile-Nr./Part-No.	Tafel/Table	Teile-Nr./Part-No.	Tafel/Table	Teile-Nr./Part-No.	Tafel/Table
0667 175040	23	0688 130260	12	0688 160640	7	0688 320710	5	0791 580100	45
0667 175060	23	0688 130280	11	0688 160683	7	0688 320740	52	0791 867300	40
0667 235010	3	0688 130363	49	0688 160724	7	0688 380020	36	0797 000412	33
0667 295050	49	0688 130384	49	0688 160730	7	0688 380040	34	0797 003031	44
0667 310563	5	0688 130390	11	0688 160760	6	0688 380120	46	0798 000677	39a,39b,41a,41b
0667 315223	4	0688 140020	37	0688 160804	30	0688 380130	34	0798 447914	47
0667 315243	4	0688 150360	18	0688 310050	4	0688 380140	46	0818 160210	6
0667 315253	4	0688 160010	7	0688 310140	8	0688 380163	3	0867 100120	40
0667 355103	19	0688 160020	7	0688 320070	10	0688 490020	38	0867 100133	40
0667 355110	19	0688 160033	7	0688 320120	7	0688 490030	32	0867 100230	40
0667 355123	19	0688 160050	31	0688 320134	5	0688 490040	32	0867 103043	39a,39b
0667 355130	19	0688 160060	31	0688 320203	5	0688 490060	32	0867 103080	39b,41b
0667 355140	19	0688 160113	7	0688 320204	5	0699 979104	17,18,34	0867 103090	39a,39b,41a,41b
0667 355173	19	0688 160123	7	0688 320230	5	0699 979265	33	0867 103100	39a,39b,41a,41b
0667 355420	19	0688 160130	7	0688 320234	5	0699 989250	20,21,36	0867 103120	39b,41b
0667 385013	6	0688 160150	7	0688 320240	5	0700 000043	43	0867 103130	39a,39b,41a,41b
0667 385033	34	0688 160153	7	0688 320250	5	0700 000044	43	0867 103170	39b,41b
0667 385143	34	0688 160214	7	0688 320260	5	0700 000045	43	0867 103193	39a,39b,41a,41b
0688 100033	36	0688 160243	7	0688 320270	5	0700 000050	43	0867 103203	39b,41b
0688 100090	36	0688 160280	6	0688 320280	5	0700 000090	45	0867 103220	40
0688 100173	1	0688 160310	7	0688 320290	5	0700 000091	45	0867 103253	41a, 41b
0688 120014	3	0688 160320	7	0688 320300	5	0700 088702	43	0867 110280	24,25,27
0688 120060	3	0688 160333	7	0688 320320	5	0742 002096	44	0867 110340	24,25,27
0688 120083	3	0688 160344	7	0688 320333	5	0744 001155	25,26,28	0867 140270	39a, 41a
0688 120094	3	0688 160350	7	0688 320380	5	0744 001793 A	44	0867 150290	16
0688 130100	13	0688 160400	7	0688 320423	5	0744 001793 B	44	0867 150323	17
0688 130103	13	0688 160474	29,30	0688 320470	5	0744 001796	44	0867 150333	18
0688 130110	13	0688 160490	7	0688 320490	5	0744 050299	40	0867 150343	17,18
0688 130120	13	0688 160514	6	0688 320510	5	0791 000007	49	0867 151050	15
0688 130130	13	0688 160610	8	0688 320530	47	0791 001081	45	0867 160274	6
0688 130140	13	0688 160620	7	0688 320690	5	0791 001094	45	0867 160650	31
0688 130243	11	0688 160630	7	0688 320700	5	0791 001096	45	0867 170174	23

Teile-Nr./Part-No.	Tafel/Table	Teile-Nr./Part-No.	Tafel/Table	Teile-Nr./Part-No.	Tafel/Table	Teile-Nr./Part-No.	Tafel/Table	Teile-Nr./Part-No.	Tafel/Table
0867 170184	23	0887 320023	9	0888 100493	39a,41a	0888 160224	6	0888 220480	52
0867 172050	23	0887 320030	9	0888 100504	2	0888 160310	47	0888 220490	52
0867 172060	23	0887 320044	9	0888 100470	39a,41a	0888 160320	47	0888 220500	50
0867 172083	23	0887 320050	9	0888 100480	39a,41a	0888 220010	50,51,52	0888 220523	50
0867 172103	23	0887 320083	9	0888 100530	39a,41a	0888 220010	51	0888 220530	50
0867 172110	23	0887 320090	9	0888 100540	39a,41a	0888 220010	52	0888 220540	52
0867 172120	23	0887 320114	9	0888 100560	39a,41a	0888 220020	50,51,52	0888 220550	50
0867 330103	20,21	0887 320143	47	0888 100580	39a,41a	0888 220020	51	0888 220564	49
0867 330110	20,21	0887 320160	48	0888 100594	41a	0888 220020	52	0888 220574	49
0867 330180	20,21	0887 320164	48	0888 100600	1	0888 220040	50,51,52	0888 220610	47
0867 330220	20,21	0887 320170	48	0888 100610	39a,41a	0888 220040	51	0888 220630	38
0867 330310	21	0887 320184	48	0888 100620	5	0888 220040	52	0888 220644	38
0867 490010	42	0887 320193	10	0888 100704	39a	0888 220090	50,51,52	0888 220690	52
0867 490390	40	0887 320200	10	0888 102148	48	0888 220270	38	0888 220760	51
0867 590034	53	0887 320210	10	0888 110630	53	0888 220280	51	0888 220770	51
0867 592184	53	0887 320220	10	0888 110640	53	0888 220290	50,51	0888 220783	51
0868 110054	27	0887 320233	10	0888 110650	53	0888 220300	51	0888 220790	51
0868 160070	46	0887 320264	10	0888 120050	47	0888 220310	50,51,52	0888 230120	3
0868 160240	6	0887 320274	10	0888 150734	15	0888 220334	50	0888 230130	3
0887 110013	36	0887 320280	10	0888 150740	15	0888 220344	50	0888 230140	3
0887 120023	3	0887 320310	10	0888 150754	15	0888 220354	50	0888 230154	3
0887 120034	3	0887 320320	5	0888 160012	47	0888 220364	51	0888 310024	47
0887 120054	3	0887 320324	5	0888 160014	47	0888 220374	51	0888 310030	47
0887 140090	53	0887 320353	10	0888 160020	47	0888 220384	51	0888 310044	8
0887 140103	53	0887 330020	21	0888 160030	47	0888 220394	52	0888 310050	4
0887 140113	53	0887 330030	21	0888 160040	47	0888 220404	52	0888 310063	4
0887 140123	53	0887 330043	21	0888 160053	47	0888 220410	50	0888 310134	47
0887 150014	53	0887 380010	34	0888 160060	47	0888 220420	52	0888 320040	48
0887 150024	53	0888 100270	1	0888 160074	29	0888 220430	50	0888 320050	48
0887 150034	53	0888 100440	41a,41b	0888 160080	47	0888 220450	52	0888 320060	48
0887 160040	6	0888 100450	41a,41b	0888 160094	47	0888 220460	52	0888 320070	48
0887 320013	9	0888 100453	41a,41b	0888 160214	6	0888 220470	52	0888 320080	48



Teile-Nr./Part-No.	Tafel/Table	Teile-Nr./Part-No.	Tafel/Table	Teile-Nr./Part-No.	Tafel/Table	Teile-Nr./Part-No.	Tafel/Table	Teile-Nr./Part-No.	Tafel/Table
0888 320090	48	0888 330723	20,21	0888 331083	22	0998 882510	24,27	9126 102540	6,29,30
0888 320100	48	0888 330733	20,21	0888 331100	22	0999 201114	37	9126 116180	8
0888 320114	48	0888 330743	20,21	0888 331110	22	0999 220752	34	9126 116200	8
0888 320132	48	0888 330750	22	0888 331120	20,21	0999 230573	7	9126 300061	17,18
0888 320142	48	0888 330760	20,21	0888 331130	20,21	0999 240302	35	9126 300088	17,18
0888 320143	48	0888 330770	20,21	0888 331140	22	0999 240305	35	9126 300089	20,21
0888 320150	48	0888 330780	20,21	0888 331150	22	0999 240376	18,34	9126 300201	4
0888 320170	48	0888 330790	20,21	0888 331160	20,21	0999 240408	21,33	9129 020120	5,50,51,52
0888 320180	48	0888 330800	20,21	0888 331220	45	1001 001162	22,36	9130 104035	48
0888 320210	48	0888 330810	20,21	0888 331230	45	1001 009243	53	9130 220160	5
0888 320220	48	0888 330820	20,21	0888 331240	42	9041 100015	7,20,21	9130 221130	2
0888 320243	48	0888 330830	20,21	0888 331254	3	9041 100025	3	9190 100113	46
0888 320440	35	0888 330840	20,21	0888 350124	19	9041 100030	17,18	9190 100226	17,18
0888 320480	35	0888 330850	22	0888 350134	19	9041 100035	34	9190 101980	45
0888 320490	35	0888 330860	20,21	0888 490140	36	9041 102030	10	9199 000004	33
0888 320500	35	0888 330880	20,21	0894 450378	39a,39b	9069 910020	25,28	9201 112447	22
0888 320510	35	0888 330890	22	0902 000423	37	9081 100251	45	9201 113677	49
0888 320520	35	0888 330903	21	0913 000731	45	9081 200253	45	9201 113697	43
0888 320530	35	0888 330914	21	0933 001544	34	9081 200303	45	9202 001668	50,51,52
0888 320543	35	0888 330923	20	0992 001020	34	9081 200500	49	9202 001678	3,23,47
0888 320814	5	0888 330930	20	0992 016580	15,16	9081 300001	49	9202 001697	5
0888 321183	5	0888 330940	20	0992 023560	15,16	9081 500010	45	9202 002057	3,6,31,34
0888 321193	5	0888 330950	20	0992 023577	15,16	9081 500051	49	9202 002058	4
0888 330653	20,21	0888 330960	20	0993 904247	49	9120 030050	9	9202 002067	13,22,34
0888 330660	20,21	0888 330964	20	0994 100940	39a,41a	9120 030110	39a,41a	9202 002068	50,51,52
0888 330673	20,21	0888 330980	20	0995 340617	45	9120 030304	39a,41a	9202 002077	17,18,30,32,34, 38,46,47,49,53
0888 330683	22	0888 330990	20	0996 010968	7	9120 030353	20,21	9202 002078	3,29,30,33
0888 330684	22	0888 331020	20	0998 881010	17,18,39a,41a	9120 040070	10	9202 002087	22,31,34,46,47
0888 330693	20	0888 331030	20,21	0998 881580	10	9122 200090	5	9202 002097	29,30,36
0888 330700	20,21	0888 331054	22	0998 881610	31	9122 322200	4	9202 002098	4,6,7,11,19,29,30
0888 330710	21	0888 331060	22	0998 881630	8	9122 915280	7	9202 002107	9,19,47,53
0888 330713	20	0888 331070	22	0998 882080	15,16,20,21	9126 102520	6,29,30		



Teile-Nr./Part-No.	Tafel/Table	Teile-Nr./Part-No.	Tafel/Table	Teile-Nr./Part-No.	Tafel/Table	Teile-Nr./Part-No.	Tafel/Table	Teile-Nr./Part-No.	Tafel/Table
9334 001670	39a,41a	9700 100100	30,31	9790 201001	35	9840 120060	39a,39b,41a,41b,	9870 867044	53
9352 000050	20,21	9700 100103	14	9790 315002	33		42	9870 867045	53
9352 000060	5	9710 061200	32	9800 210001 R	42	9840 120104	19,34	9870 888003	33
9352 000140	53	9710 063000	21	9800 210003 R	40	9840 120105	31,34	9870 888005	33
9352 000163	8	9710 900035	32	9800 560001	22	9840 121001	33,34,39a,39b, 41a,41b,47	9870 967001	41a,41b
9352 000200	39a,41a	9710 920012	21,32	9805 791113	49	9840 123002	42	9880 001001	39a,39b,41a,41b
9352 000250	6	9710 982003	21,32	9815 301102	33	9840 123003	39a,39b,41a,41b, 47	9880 001005	42
9352 640050	46	9731 001035	34	9820 110017	25,28			9880 867030	39b
9353 000087	17,18	9731 002001	44	9820 110018	13	9840 130007	34	9880 867031	40
9353 000130	5	9731 005004	14,21,26,30,31, 33,35	9820 110019	31	9840 130008	34	9880 867101	33,49
9353 000158	50,51,52			9820 110040	19	9840 133012	47	9880 887030	39a
9353 000350	2	9731 006004	35	9822 560000	38	9850 001083	47	9880 888040	41b
9353 000420	2,39a,41a	9731 007021	7	9822 560001	38	9850 001089	47	9880 888041	41a
9353 000470	1,2	9731 007035	3	9825 511003	41a,41b	9850 001309	41a,41b	9880 888100	38
9354 010090	5	9740 000607	20,21	9825 550001	32,33	9850 001311	42	9880 888102	33
9354 010210	2	9740 001215	7	9825 551102	53	9850 001330	40	9880 888104	38
9354 400800	17,18,34	9740 001220	35	9830 501010	32	9850 001340	42	H667 490050	41a,41b
9357 000050	19,48	9740 001525	35	9830 501011	33	9850 281002	39a,41a,41b	MG43 000062	43
9357 000060	7,13,20	9740 005810	7	9830 502005	47	9850 688001	33	MG53 002501	43
9357 000070	12,14,17,18,23, 29,30	9742 000130	7	9830 502007	39a,39b	9850 838000	32	MG53 007511	43
9357 000080	20,21,24,27	9742 000180	7	9830 502014	34	9850 867010	39b	MG53 007921	44
9357 000090	3,4,7,12,20,21	9742 300195	14	9835 901005	47	9850 867023	53	MG53 007922	44
9357 000100	9,29,30,39a,41a	9760 000001	35	9840 120001	39a,39b,41a,41b	9850 867024	53	MG55 000501	43
9357 000120	6,29,30	9780 000108	44	9840 120003	42,47	9870 001113	45	N800 005139	49
9357 000140	11	9781 000006	35	9840 120025	47	9870 275005	21	N800 075013	47
9380 520150	50,51,52	9790 000220	33	9840 120026	22,34,35,53	9870 367003	32	N800 080003	47
9380 520190	22	9790 020010	35	9840 120027	35,41a,41b	9870 688001	42	N800 080004	47
9380 521220	49	9790 060104	21	9840 120028	34	9870 688002	33	N800 080030	47
9400 000090	37	9790 111001	35	9840 120029	41a,41b	9870 867000	42	N800 688014	47
9401 000194	40,42	9790 200000	21,32	9840 120031	36	9870 867018	53	S080 190359	47
9401 000204	40,42	9790 200001	35	9840 120032	38	9870 867019	39a,39b	S080 260617	36
		9790 201000	21,32,35	9840 120052	38	9870 867023	40	S080 271529	47



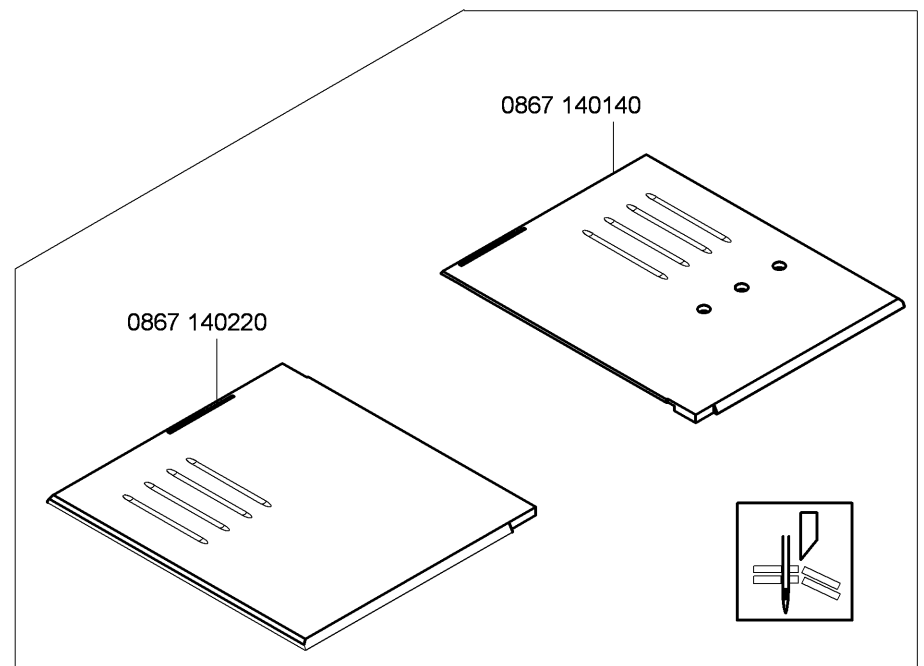
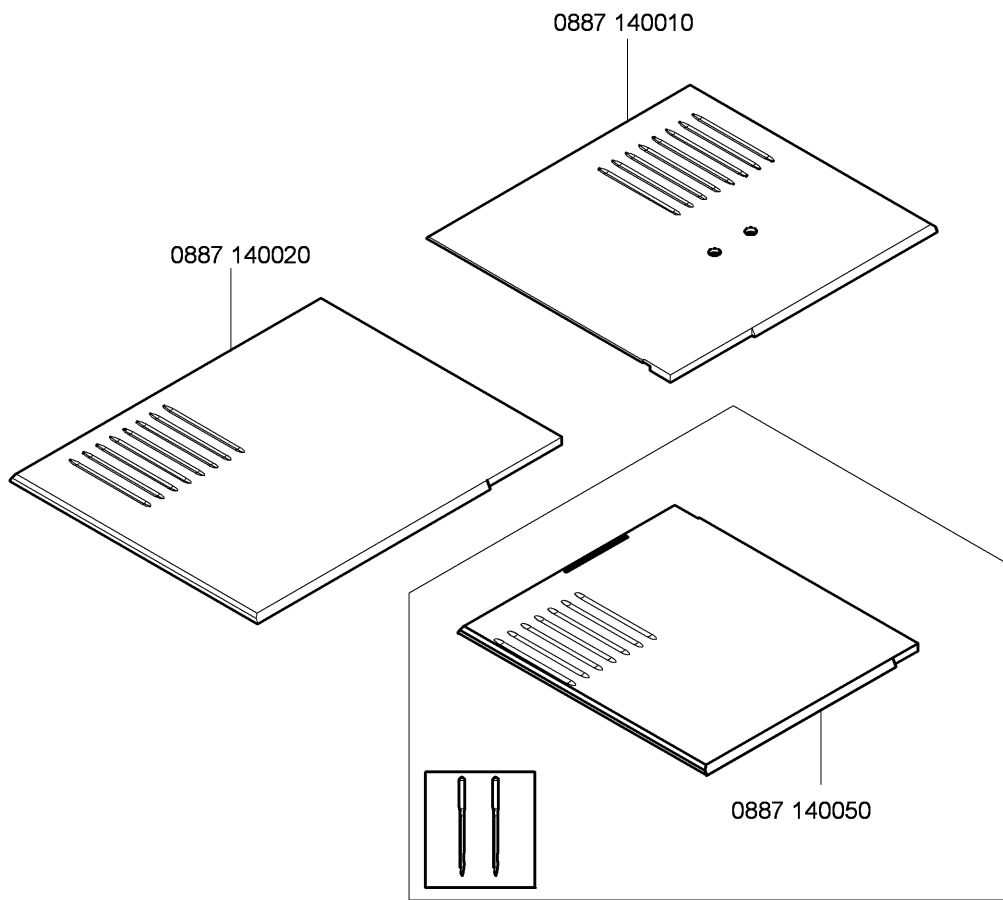



E1  
E2  
E3  
E4  
E5

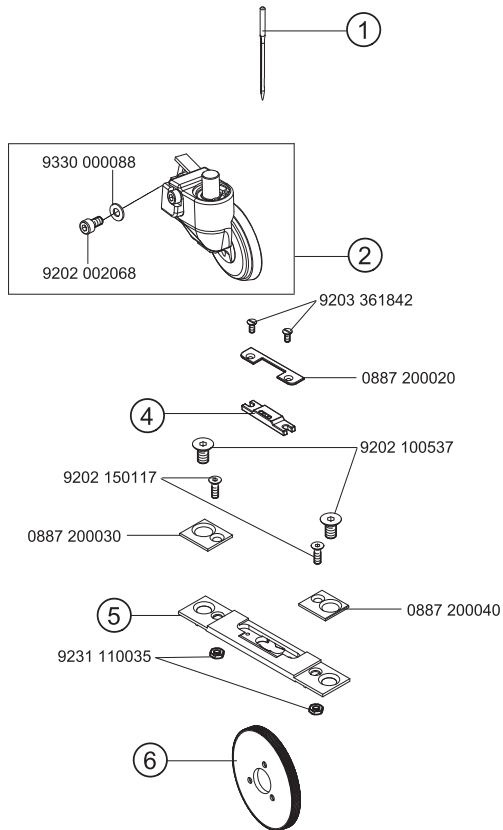

E6/1,3  
E7/1,7  
E8/2,0

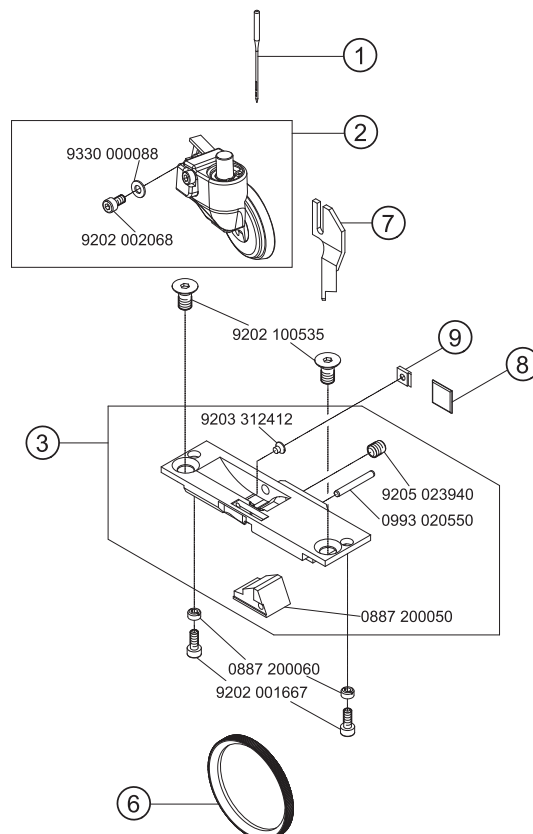



E9/1,3

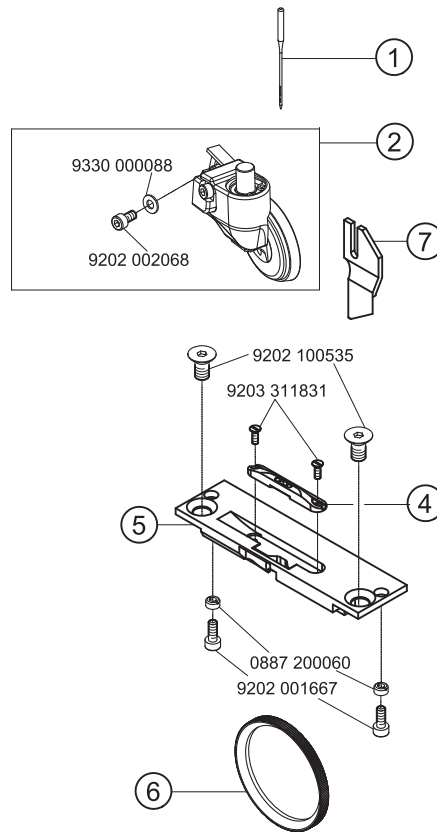

E10/2,0  
E12/2,0  
E14/2,4

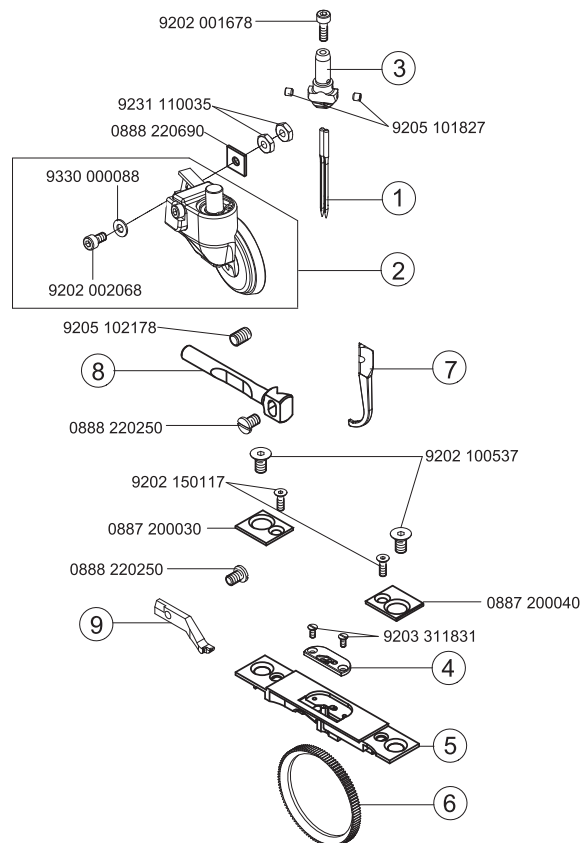



E11/1,6  
E13/1,6

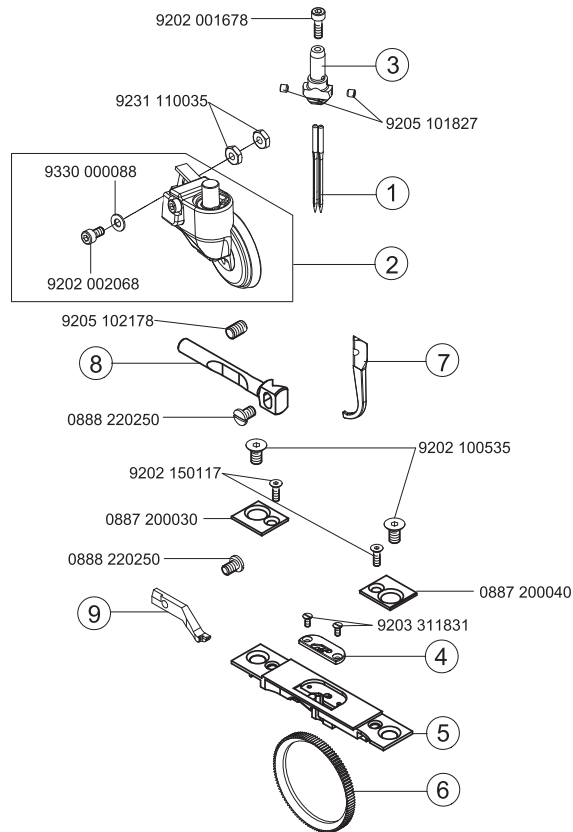

E15/2,0  
E16/2,4

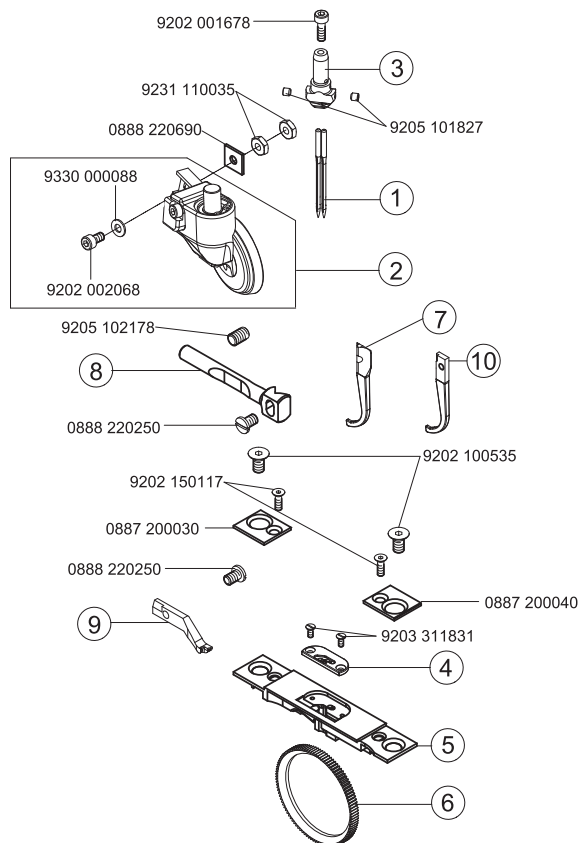





E-Nr. E-No.	Abb.-Nr. Fig.No.	Für Unterklasse / For Subclass Verwendungszweck / Use	Material No. / Material Nr.	Nadelzahl/Number of needles	Nadelhalter/ Needle holder	Nadelabstand/Needles distance	Nadelsystem / -dicke / Needle system / -size ①	angetriebene Rollfüß/Top roller driven ②	Durchmesser des Presserfußes/Top roller diameter	Nadelführung, vorn/Needle guide front	Halter des Nadelführungs, vorn/Holder of needle guide front	Nadelführung, hinten/Needle guide rear	Stichplatteneinsatz/Throat plate insert ④	Stichplatteneinsatz-Lochbreite/Insert hole width ⑤	Stichplatte/Throat plate ⑥	Stichplatte komplett/Throat plate complete ⑦	Schiebradtransporteur/Wheel feeder ⑧	Verzahnungsabstand des Transporteurs/Wheel feed tooth pitch ⑨	Obermesser/Knife upper	Untermesser/Knife lower	Lasche/Fishplate
E1		-160020; -160122 Näheinrichtung, Nadelstärke Nm 70-80, Stichlänge max. 4 mm, für leichtes Nähgut. Sewing equipment, needle size Nm 70-80, stitch length max. 4 mm, for light weight material.	0887 E00104	1			134 LR - 80	0888 220364	35				0888 200040	1,4	0887 200010		0887 320060	0,6			
E2		-160020; -160040; -160122; -160142; -160542 Näheinrichtung, Nadelstärke Nm 90-110, Stichlänge max. 5 mm, für mittelschweres Nähgut. Sewing equipment, needle size Nm 90-110, stitch length max. 5 mm, for medium weight material.	0887 E00205	1			134 LR - 90	0888 220364	35				0888 200050	1,8	0887 200010		0887 320060	0,6			
E3		-160020; -160040; -160122; -160142; -160542 Näheinrichtung, Nadelstärke Nm 120-160, Stichlänge max. 7 mm, für schweres Nähgut. Sewing equipment, needle size Nm 120-160, stitch length max. 7 mm, for heavy weight material.	0887 E00307	1			134 LR - 120	0888 220364	35				0888 200060	2,4	0887 200010		0887 320060	0,6			
E4		-160020; -160040; -160122; -160142; -160542 Näheinrichtung, Nadelstärke Nm 90-110, Stichlänge max. 5 mm, für mittelschweres Nähgut. Sewing equipment, needle size Nm 90-110, stitch length max. 5 mm, for medium weight material.	0887 E00405	1			134 LR - 90	0888 220334	25				0888 200050	1,8	0887 200010		0887 320060	0,6			
E5		-160020; -160040; -160122; -160142; -160542 Näheinrichtung, Nadelstärke Nm 90-110, Stichlänge max. 5 mm, für mittelschweres Nähgut. Sewing equipment, needle size Nm 90-110, stitch length max. 5 mm, for medium weight material.	0887 E00505	1			134 LR - 90	0888 220354	25				0888 200050	1,8	0887 200010		0887 320060	0,6			



E-Nr. E-No. Abb.-Nr. Fig.No.	Für Unterklasse / For Subclass Verwendungszweck / Use	Material No. / Material Nr.	Nadelzahl/Number of needles	Nadelhalter/ Needle holder	Nadelabstand/Needles distance	Nadelsystem / -dicke / Needle system / -size	angetriebene Rollfüß/Top roller driven	Durchmesser des Presserfußes/Top roller diameter	Nadelführung, vorn/Needle guide front	Halter des Nadelführungs, vorn/Holder of needle guide front	Nadelführung, hinten/Needle guide rear	Stichplatteneinsatz/Throat plate insert	Stichplatteneinsatz-Lochbreite/Insert hole width	Stichplatte/Throat plate	Stichplatte komplett/Throat plate complete	Schieberadtransporteur/Wheel feeder	Verzahnungsabstand des Transporteurs/Wheel feed tooth pitch	Obermesser/Knife upper	Untermesser/Knife lower	Lasche/Fishplate
E6/1,3	-363122; -363522 Näheinrichtung zum Nähen und Beschneiden, Schneidabstand 1,3 mm, Nadelstärke Nm 70-80, Stichtlänge max. 5 mm, für leichtes Nähgut. Sewing equipment for stitching and trimming, trimming distance 1.3 mm, needle size Nm 70-80, stitch length max. 5 mm, for light weight material.	0887 E00605 13	1			134 LR - 80	0888 220364	35						0887 200074	0688 320520	0,6	0887 330010	0887 200090	0887 200080	
E7/1,7	-363122; -363522 Näheinrichtung zum Nähen und Beschneiden, Schneidabstand 1,7 mm, Nadelstärke Nm 90-120, Stichtlänge max. 5 mm, für mittelschweres Nähgut. Sewing equipment for stitching and trimming, trimming distance 1.7 mm, needle size Nm 90-120, stitch length max. 5 mm, for medium weight material.	0887 E00705 17	1			134 LR - 120	0888 220364	35						0887 200134	0688 320520	0,6	0887 330010	0887 200150	0887 200260	
E8/2,0	-363122; -363522 Näheinrichtung zum Nähen und Beschneiden, Schneidabstand 2,0 mm, Nadelstärke Nm 120-160, Stichtlänge max. 5 mm, für schweres Nähgut. Sewing equipment for stitching and trimming, trimming distance 2.0 mm, needle size Nm 120-160, stitch length max. 5 mm, for heavy weight material.	0887 E00805 20	1			134 LR - 160	0888 220364	35						0887 200144	0688 320520	0,6	0887 330010	0887 200150	0887 200260	
E9/1,3	-363122; -363522 Näheinrichtung zum Nähen und Beschneiden, Schneidabstand 1,3 mm, Nadelstärke Nm 90-120, Stichtlänge max. 5 mm, für mittelschweres Nähgut. Sewing equipment for stitching and trimming, trimming distance 1.3 mm, needle size Nm 90-120, stitch length max. 5 mm, for medium weight material.	0887 E00905 13	1			134 LR - 100	0888 220364	35			S080 811868		0887 200430	0688 320520	0,6	0887 330100				



E-Nr. E-No.	Für Unterklasse / For Subclass	Material No. / Material Nr.	Nadelzahl/Number of needles	Stichabstand/Seam distance	Nadelhalter link/ Needle holder left	Nadelhalter recht/ Needle holder right	Nadelhalter/ Needle holder	Nadelabstand-Nadelhalter/Needles distance-needle holder	Nadelsystem / -dicke / Needle system / -size	angetriebene Rollfüß/Top roller driven	Durchmesser des Presserfußes/Top roller diameter	Nadelführung, vom/Needle guide front	Halter des Nadelführungs, vom/Holder of needle guide front	Nadelführung, hinten/Needle guide rear	Nadelführung, hinten/Needle guide rear	Stichplatteneinsatz/Throat plate insert	Stichplatteneinsatz-Lochbreite/Insert hole width	Stichplatte/Throat plate	Schnebradtransporteur/Wheel feeder	Verzahnungsabstand des Transporteurs/Wheel feed tooth pitch
E10/2,0	-260020; -260122 Näheinrichtung, Stichabstand 2,0 mm, Nadelstärke Nm 90-110, Stichlänge max. 4 mm, für mittelschweres Nähgut. Sewing equipment, seam distance 2,0 mm, needle size Nm 90-110, stitch length max. 4 mm, for medium weight material.	0887 E01004 20	2	2,0			0888 230023	3,4	134 KCLR - 90	0888 220364	35	0888 220170	0888 220240	0888 220200		0888 200130	1,5	0887 200110	0688 320520	0,6
E11/1,6	-260020; -260122 Näheinrichtung, Stichabstand 1,6 mm, Nadelstärke Nm 70-80, Stichlänge max. 4 mm, für leichtes Nähgut. Sewing equipment, seam distance 1,6 mm, needle size Nm 70-80, stitch length max. 4 mm, for light weight material.	0887 E01104 16	2	1,6			0888 230013	2,96	134 KCLR - 80	0888 220364	35	0888 220170	0888 220240	0888 220190		0888 200120	1,5	0887 200120	0688 320520	0,6
E12/2,0	-260020; -260122 Näheinrichtung, Stichabstand 2,0 mm, Nadelstärke Nm 70-80, Stichlänge max. 4 mm, für leichtes Nähgut. Sewing equipment, seam distance 2,0 mm, needle size Nm 70-80, stitch length max. 4 mm, for light weight material.	0887 EE01204 20	2	2,0			0888 230023	3,4	134 KCLR - 80	0888 220364	35	0888 220170	0888 220240	0888 220200		0888 200130	1,5	0887 200110	0688 320520	0,6
E13/1,6	-260020; -260122 Näheinrichtung, Stichabstand 1,6 mm, Nadelstärke Nm 90-110, Stichlänge max. 4 mm, für mittelschweres Nähgut. Sewing equipment, seam distance 1,6 mm, needle size Nm 90-110, stitch length max. 4 mm, for medium weight material.	0887 E01304 16	2	1,6			0888 230013	2,96	134 KCLR - 90	0888 220364	35	0888 220170	0888 220240	0888 220190		0888 200120	1,5	0887 200120	0688 320520	0,6
E14/2,4	-260020; -260122 Näheinrichtung, Stichabstand 2,4 mm, Nadelstärke Nm 90-110, Stichlänge max. 5 mm, für mittelschweres Nähgut. Sewing equipment, seam distance 2,4 mm, needle size Nm 90-110, stitch length max. 5 mm, for medium weight material.	0887 E01405 24	2	2,4			0888 230023	3,4	134 KCLR - 90	0888 220364	35	0888 220170	0888 220240	0888 220210		0888 200140	1,5	0887 200100	0688 320520	0,6



E-Nr. E-No.	Für Unterklasse / For Subclass	Material No. / Material Nr.	Nadelzahl/Number of needles	Stichabstand/Seam distance	Nadelhalter link/ Needle holder left	Nadelhalter recht/ Needle holder right	Nadelhalter/ Needle holder	Nadelabstand-Nadelhalter/Needles distance-needle holder	Nadelsystem / -dicke / Needle system / -size	angetriebene Rollfüß/Top roller driven	Durchmesser des Presserfußes/Top roller diameter	Nadelführung, vom/Needle guide front	Halter des Nadelführungs, vom/Holder of needle guide front	Nadelführung, hinten/Needle guide rear	Nadelführung, hinten/Needle guide rear	Stichplatteneinsatz/Throat plate insert	Stichplatteneinsatz-Lochbreite/Insert hole width	Stichplatte/Throat plate	Scheibradtransporteur/Wheel feeder	Verzahnungsabstand des Transporteurs/Wheel feed tooth pitch
E15/2,0	-260020; -260122 Näheinrichtung, Stichabstand 2,0 mm, Nadelstärke Nm 120-160, Stichlänge max. 4 mm, für schweres Nähgut. Sewing equipment, seam distance 2,0 mm, needle size Nm 120-160, stitch length max. 4 mm, for heavy weight material.	0887 E01504 20	2	2,0			0888 230023	3,4	134-35 LR - 130	0888 220364	35	0888 220170	0888 220240	0888 220200	0888 220230	0888 200170	2,3	0887 200110	0688 320530	1,2
E16/2,4	-260020; -260122 Näheinrichtung, Stichabstand 2,4 mm, Nadelstärke Nm 120-160, Stichlänge max. 5 mm, für schweres Nähgut. Sewing equipment, seam distance 2,4 mm, needle size Nm 120-160, stitch length max. 5 mm, for heavy weight material.	0887 E01605 24	2	2,4			0888 230023	3,4	134-35 LR - 130	0888 220364	35	0888 220170	0888 220240	0888 220210	0888 220230	0888 200180	2,3	0887 200100	0688 320530	1,2

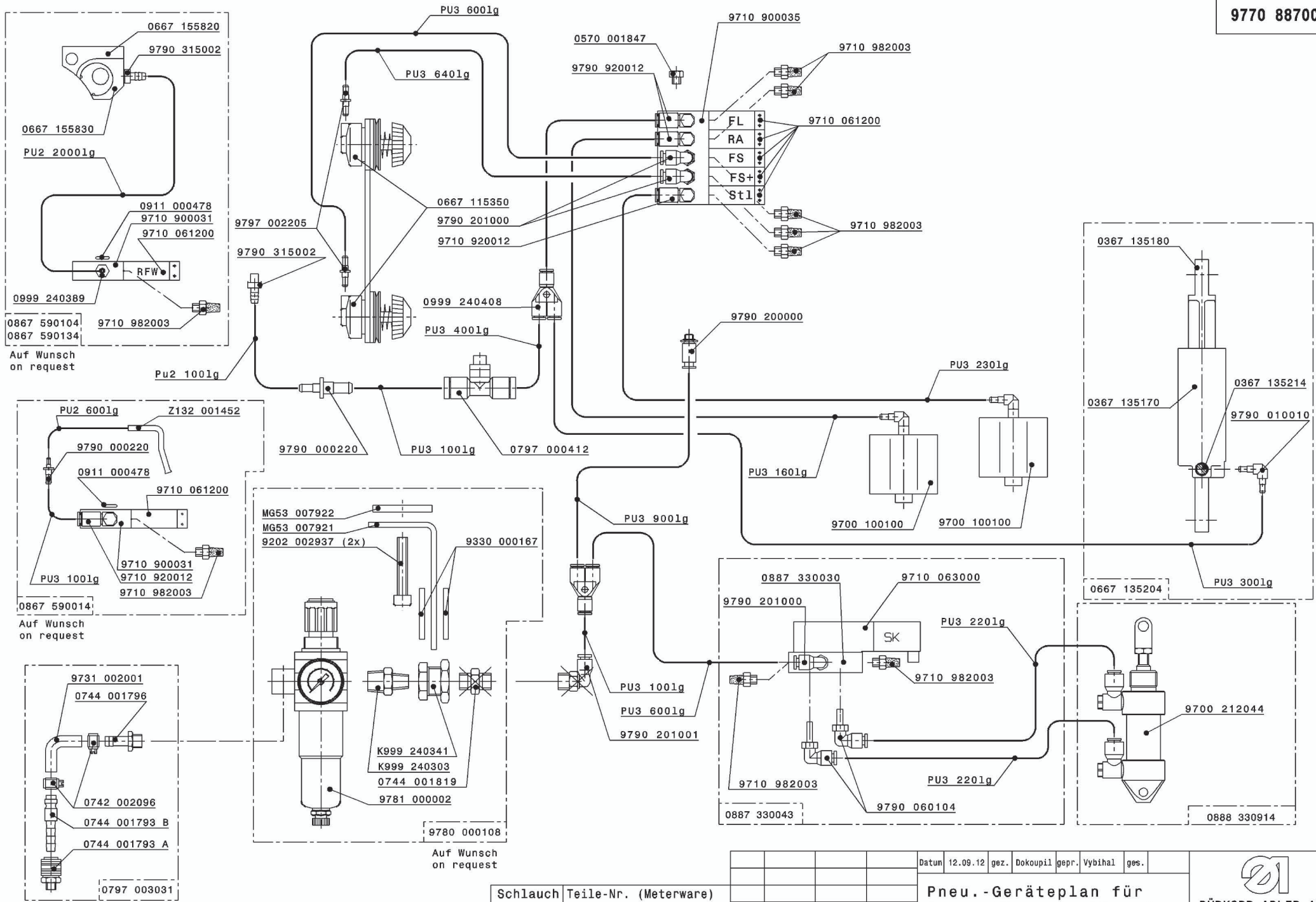

Schutzvermerk  
DIN  
A3  
ISO 15016 beachten

Schlauch Hose	Teile-Nr. (Meterware) Part-No. (Yarded goods)
PU2	0699 979265
PU3	9731 005004
PU4	9731 006004

Änd.	Datum	gez.	gepr.

Datum 12.09.12 gez. Dokoupil gepr. Vybihal ges.  
**Pneu.-Geräteplan für  
Pneu.-Elements-Plan for  
0887-363522**



**DÜRKOPP ADLER AG**  
**9770 887001**  
Blatt 1 | Blattz. 2



