



Teileliste und Näheinrichtungen
Spare Parts List and Sewing Equipment

550-16

DÜRKOPP ADLER AG

Postfach 17 03 51, D-33703 Bielefeld • Potsdamer Straße 190, D-33719 Bielefeld
Telefon (05 21) 9 25-0 • Telefax (05 21) 9 25 24 35

Teile-Nr./Part-No.: 0791 550805



Teileliste und Näheinrichtungen
Spare Parts List and Sewing Equipment

550-16...

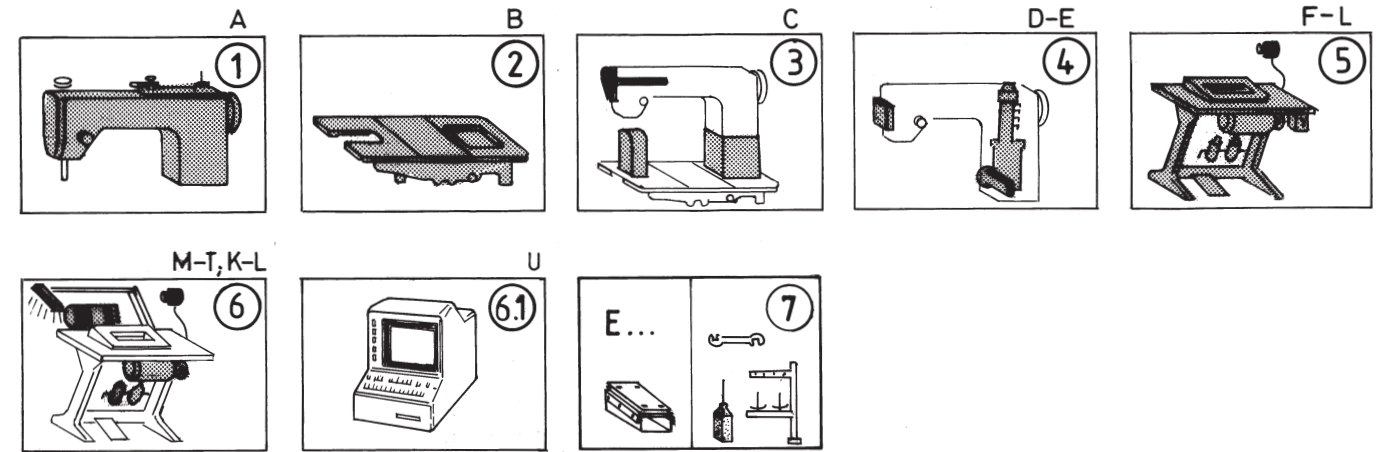
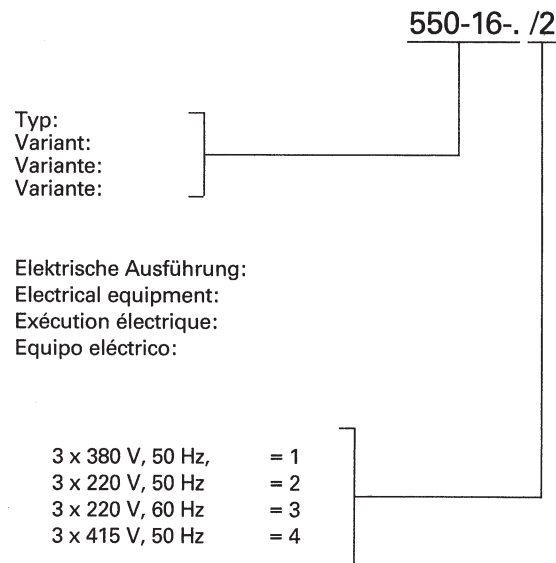
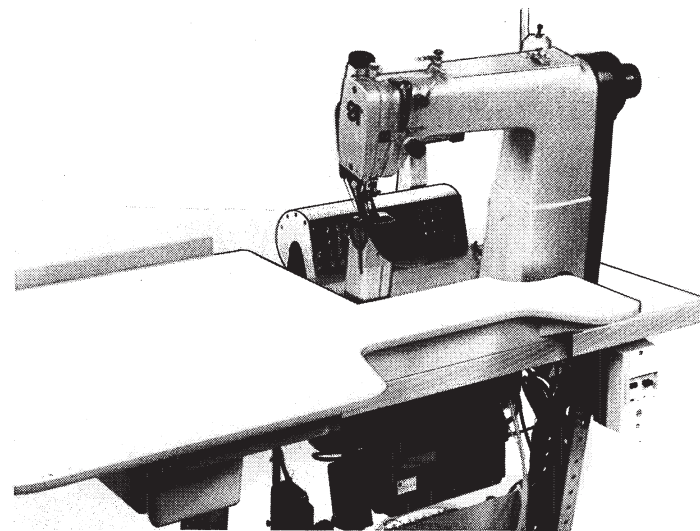

Unterklassen-Tabelle

Table of sub classes

Z e i l e	Unterklasse: Sub class:	Gruppenaufstellung der Unterklassen: Zum Beispiel: A } A1 Tabel of sub class: for example: A } A1																									
	550-16...	A	B	C	D	E	F	G	H	J	K	L	M	N	O	P	Q	R	S	T	U	V	W	X	Y	Z	
1	550-16-2	1	1	1	1	-	1	1	2	1	1	1	-	1	1	1	-	1	-	-	-	-	-	-	-	-	-
2	550-16-3	1	1	1	-	1	1	-	2	1	3	2	1	1	1	-	-	-	-	1	-	-	-	-	-	-	-
3	550-16-5	1	1	1	-	1	1	-	1	1	3	3	2	1	1	-	1	-	1	-	-	-	-	-	-	-	-
4	550-16-6	1	1	1	-	1	1	-	1	1	3	3	-	1	1	-	1	-	-	-	-	1	-	-	-	-	-

INFORMATION ZUR HANDHABUNG DER TEILELISTE

1. Allgemeines

1.1 Im Inhaltsverzeichnis sind die Teile-Nr. nach steigenden Nr. geordnet.

1.2 Teile-Nr. 993 91 081 7 Zyl.-Schr. M4 x 10 2 - B 10
Benennung
Abmessung
Bildtafel Nr. (rechts und links oben in der Bildtafel eingekreiste Nr.)
Planquadrat der jeweiligen Bildtafel

1.5 Zu einer Einheit gehörende Einzelteile sind durch eine strichpunktierte Linie eingerahmt. Die Einheit kann auch komplett unter der voll eingerahmten Teile-Nr. bestellt werden. Zu dieser Einheit gehören keine Teile, deren Nr. außerhalb der strichpunktierten Linie steht.

2.1 Verwendete Bildzeichen

- N = nicht als Einzelteil lieferbar
- Mg = mustergebunden, bei Ersatzteilebestellung bitte Muster einschicken oder Form-Nr. angeben
- ☞ = siehe Mechanikeranleitung
- ☒ = fluessig sichern, kleben, dichten
Loctite 270, Nr.990 49 034 6

- ☐ = Laenge oder Flaechte
- ✂ = ohne Fadenabschneider
- ✂ = mit Fadenabschneider
- ☞ = links
- ☜ = rechts

- ← = Hinweis auf Unterscheidungsmerkmal
- mm = Maße
- V = veraltete Ausfuehrung
- q.W. = auf Wunsch

2.3 Sollten Sie ein Teil nicht in der Ersatzteilleiste auffinden, was durch technische Änderungen vorkommen kann, dann geben Sie uns bitte zur Teile- und Funktionsbeschreibung, evtl. Teil skizzieren, die genaue Unterklasse und Fabrik-Nr. lt. Typenschild bekannt.

3. Elektro-Teile

- 3.1 Bei Elektrokabeln und pneumatischen Schläuchen ist es erforderlich, die gewünschte Meterzahl anzugeben.
- 3.2 Bei Bestellungen von Elektroteilen bitten wir die zusätzlichen Angaben, die in Klammern hinter der Teile-Nr. stehen, mit anzugeben.
- 3.3 Elektroteile sind zum schnellen Auffinden im Lageplan mit einer Positions-Nr. gekennzeichnet. Die Teile sind wie in Punkt 1.5 beschrieben aufgeführt.
- 3.4 Nicht nummerierte Elektroteile können nach der Bezeichnung z.B. "Transistor T6" oder "Widerstand 1K 0,5W" und der dazugehörenden Stromlaufplan-Nr. bestellt werden.
- 5. Jeder Nachdruck, auch der auszugsweise, ist nur mit unserer Genehmigung gestattet. Änderungen behalten wir uns vor.

INFORMATION ON USING THE SPARE PARTS LIST

1. In general

1.1 The part numbers are listed in numerical order in the table of contents.

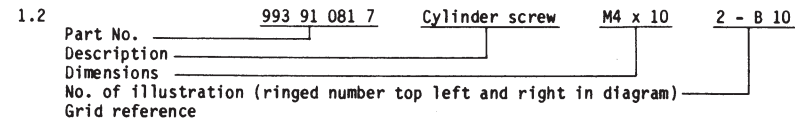

1.5 The component parts belonging to a "unit" are shown enclosed within a dot-dash frame. A "unit" can also be ordered complete by quoting the fully enclosed number within the dot-dash frame. Any parts, the numbers of which are shown outside the dot-dash frame, are not included with the "unit" and must be ordered separately.

2.1 Symbols applied

- | | | | |
|--|--|-------------------------|-------------------------|
| N = not available as separate part | | = declar length or area | ← = point of alteration |
| Mg = calls for a sample; when ordering a spare part please submit a sample or indicate the number of the shape | | = without thread cutter | mm = measurement |
| ◁ = see mechanics manual | | = with thread cutter | V = obsolete |
| | | = left | a.W. = on request |
| | | = right | |
- = secure by glueing, seal
Loctite 270, No 990 49 034 6

2.3 Should a part not be found in the spare parts list, possibly due to technical alteration, please describe the part and its function as fully as possible when ordering. Please quote also the sub-class and serial number according to the specification plate.

3. Electrical parts

- 3.1 Please quote the required length in meters for electric cables and pneumatic hoses.
- 3.2 When ordering electrical parts, please include the additional data in brackets behind the part number.
- 3.3 To facilitate quick location, electrical components are marked with a position number in the situation-plan in the upper right hand corner of each electro sheet. Please order as in 1.5.
- 3.4 Electrical parts which are not numbered can be ordered according to their specification, e.g. "Transistor T6" or "Resistor 1 K 0.5 W" and the appropriate circuit plan.
5. All reproductions, whether whole or in part, require our permission. Technical specifications subject to alteration.

INSTRUCTIONS RELATIVES A L'UTILISATION DE LA LISTE DE PIECES DE RECHANGE

1. Généralités

1.1 Dans la table des matières, les numéros de pièces sont classés dans l'ordre croissant:

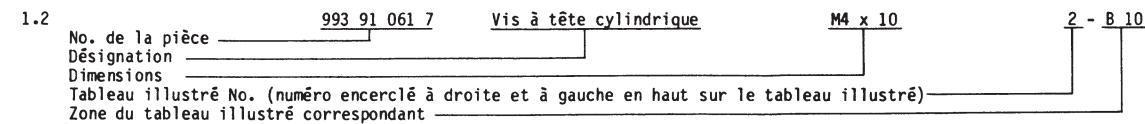

1.5 Les pièces détachées faisant partie d'une unité sont encadrées d'une ligne en traits et points. L'unité peut aussi être commandée, sous le numéro entièrement encadré (dans une case), comme unité complète. Cette unité ne comprend pas les pièces dont le numéro est marqué à l'extérieur de la ligne en traits et points.

2.1 Symboles utilisés

- | | | | |
|--|--|--------------------------------|--|
| N = non livrable comme pièce indivle | | = indiquer longueur ou surface | ← = indication pour point de variation |
| Mg = nécessite un échantillon; lorsque vous commandez une pièce de rechange veuillez soumettre un échantillon ou spécifiez le numéro de la forme | | = sans coupe-fil | mm = mesures |
| ◁ = voir instructions pour le mécanicien | | = avec coupe-fil | V = ancien model |
| | | = gauche | a.W. = sur demande |
| | | = droite | |
- = coller, fermer hermétiquement
Loctite 270, No. 99049 034 6

2.3 Pour le cas où vous ne trouveriez pas une pièce dans la liste des pièces de rechange, ce qui pourrait arriver à la suite de modifications techniques, nous vous prions de nous fournir, avec la description des pièces et du fonctionnement, des croquis des pièces éventuels, la sous-classe exacte et le numéro d'usine, tel qu'il est marqué sur la plaquette de type.

3. Pièces de la partie électrique

- 3.1 Pour les câbles électriques et les tuyaux pneumatiques, il est indispensable de nous communiquer le nombre de mètres désiré.
- 3.2 Veuillez nous préciser, dans les commandes de pièces pour la partie électrique, les indications supplémentaires marquées entre parenthèses après les numéros de pièces.
- 3.3 Les pièces de la partie électrique sont repérées par un numéro de position, afin qu'il soit possible de les trouver rapidement sur le plan de position. Les pièces sont indiquées comme mentionné au point 1.5.
- 3.4 Les pièces de la partie électrique non numérotées peuvent être commandées selon la désignation, par exemple "Transistor T6" ou "Résistance 1 K 0,5 W" et le numéro du schéma développé correspondant.
5. Toute réimpression, même partielle, est interdite sans notre autorisation. Nous nous réservons le droit de procéder à des changements.

INFORMACIONES RELATIVAS A LA UTILIZACIÓN DE LA LISTA DE LAS PIEZAS DE RECAMBIO

1. informaciones generales

1.1 En el índice, los números de las piezas de recambio están especificados en el orden creciente.

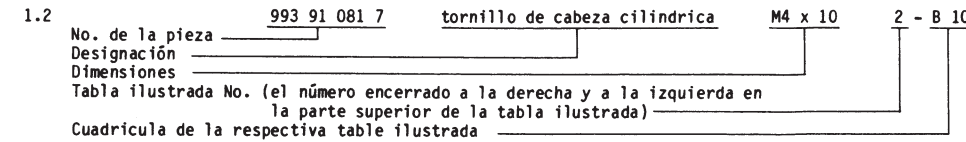

1.5 Las piezas individuales que pertenecen a una unidad están encerrados por una línea de trazos y puntos. Es también posible pedir la unidad completa precisando el número de la pieza enteramente encerrado. Esta unidad no incluye las piezas cuyo número se encuentra fuera de la línea de trazos y puntos.

2.1 Símbolos empleados

- | | | | |
|--|--|------------------------------|-------------------------------------|
| N = No se entrega como pieza individual | | = Indicar largo y superficie | ← = Advertencia de que hay |
| MG = Exige la muestra, al pedir la pieza de recambio hay que someter la muestra o precisar el número de la forma | | = Sin cortahilos | mm = medidas |
| ◁ = Vase Instrucciones para el mecánico | | = Con cortahilos | V = Estado de fabricación anticuado |
| | | = izquierda | a.W. = a petition |
| | | = derecha | |
- = Asegurar con líquido, pegar, obturar
Loctite 270, no990 49 034 6

2.3 Si Vd. no puede encontrar una pieza en la lista de las piezas de recambio, lo que es posible en caso de modificaciones técnicas, entonces rogamos describir la pieza y el funcionamiento y bosquejar eventualmente la pieza y especificar la sub-clase y el número de fabricación según la placa indicadora de tipo.

3. Piezas del sistema eléctrico

- 3.1 En caso de cables eléctricos y de tubos neumáticos hay que indicar el largo deseado en metros.
- 3.2 Al pedir piezas eléctricas, precisar también los detalles contenidos entre paréntesis detrás del número de la pieza.
- 3.3 Las piezas del sistema eléctrico llevan un número de referencia. Así es posible localizarlas más rápidamente en el plano de posición. Las piezas son indicadas según el punto 1.5.
- 3.4 Las piezas eléctricas no numeradas pueden ser pedidas indicando la designación, por ejemplo "Transistor T6" o "resistencia 1K 0,5 W" así como el número del esquema de los circuitos.
5. Está prohibida toda reproducción, incluso parcial, sin nuestra autorización. Nos reservamos el derecho de proceder a modificaciones.

INFORMAZIONE PER L'UTILIZZAZIONE DEL LIBRETTO PARTI DI RICAMBIO

1. Generalità

1.1 Nell'indice i numeri dei pezzi sono ordinati secondo numero progressivo.

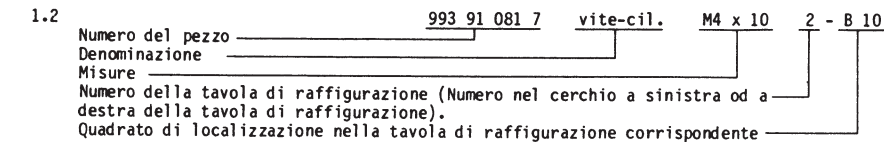

1.5 Pezzi singoli componenti un gruppo sono racchiusi in una linea a punti e tratti. Il gruppo può essere anche ordinato completo indicando all'ordine il numero di pezzo incorniciato da una linea continua. I pezzi il cui numero è situato fuori della linea a punti e tratti non appartengono al gruppo.

2.1 Abbreviazioni e simboli utilizzati:

- | | | | |
|---|--|---|--|
| N = Non fornibile come pezzo singolo | | = Indicare la lunghezza o la superficie | ← = Indicazione per notare le difference tra i pezzi |
| MG = Dipendente dal campione, ordinando i pezzi di ricambio. Inviare un campione oppure indicare il numero di forma | | = Senza rasafilo | mm = Misura |
| ◁ = Indicare la lunghezza o la superficie | | = Con rasafilo | V = Esecuzione invecchiata |
| | | = Sinistra (o) | a.W. = A richiesta |
| | | = Destra (o) | |
- = Fissaggio, incollaggio o tenuta del pezzo tramite liquido Loctite 270, Nr. 990 48 034 6

2.3 Nel caso che un pezzo non si trovi nel libretto parti di ricambio, caso che può accadere a causa delle continue innovazioni tecniche, indicate, accanto alla descrizione della funzione del pezzo e l'eventuale schizzo o descrizione minuta del pezzo, la classe e sottoclasse esatta ed il numero di fabbricazione riportati in targhetta

3. Componenti elettrici

- 3.1 Ordinando cavi elettrici o tubi pneumatici è necessario indicare la lunghezza in metri.
- 3.2 Ordinando componenti elettrici indicare i dati suppletivi segnati in parentesi dietro il numero del pezzo.
- 3.3 I componenti elettrici sono contrassegnati con un numero di posizione nella planimetria per facilitare e sveltire la loro localizzazione. I pezzi sono contraddistinti come descritto nel punto 1.5.
- 3.4 Componenti elettrici non numerati possono essere ordinati sotto il simbolo dello schema elettrico per esempio "Transistor T6" oppure "Resistenza 1K 0,5W" indicando suppletivamente il numero dello schema elettrico al quale i componenti appartengono.
5. Ogni riproduzione intera o parziale è permessa solo con la nostra approvazione. Ci riserviamo ogni diritto di modifica.

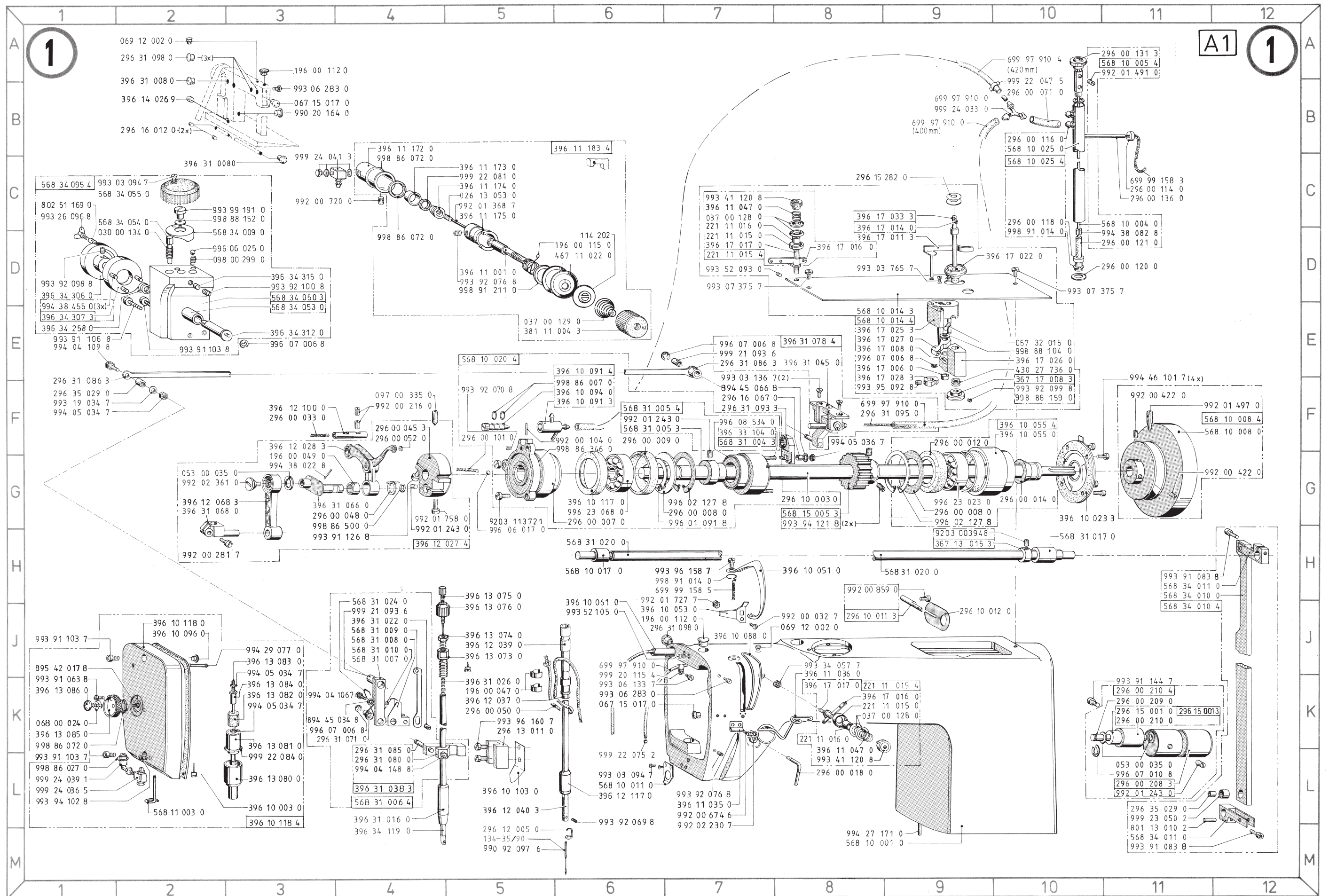

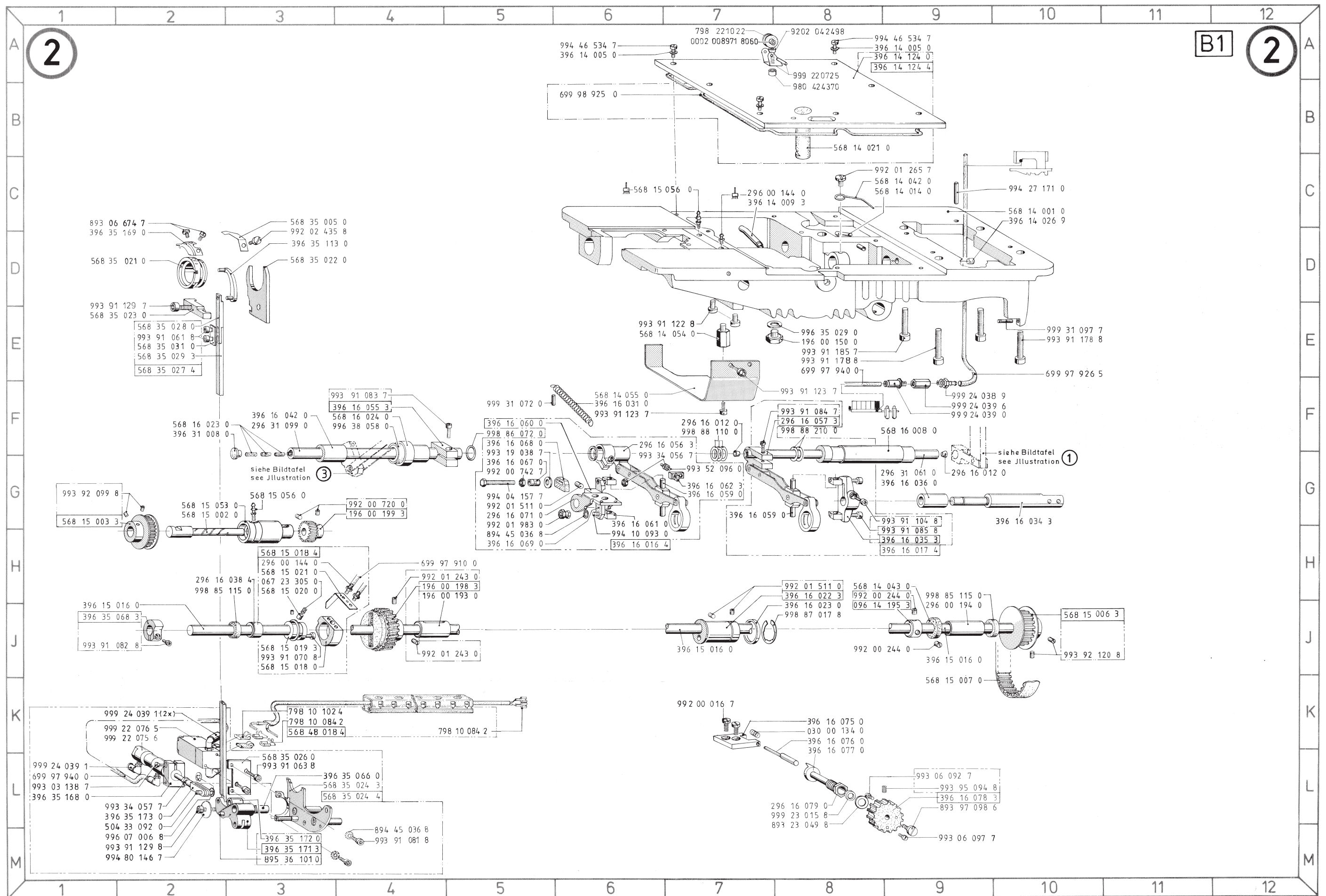

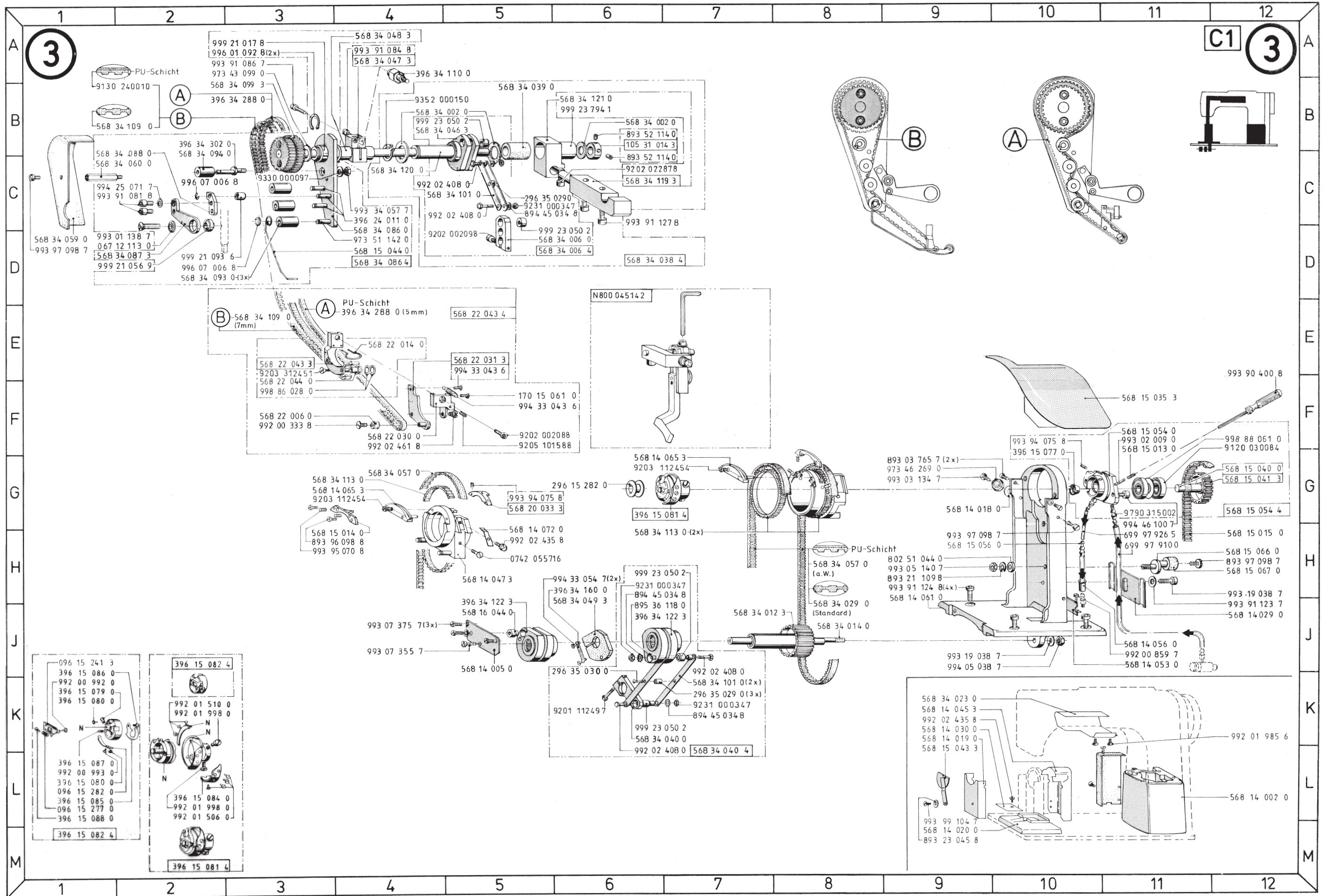

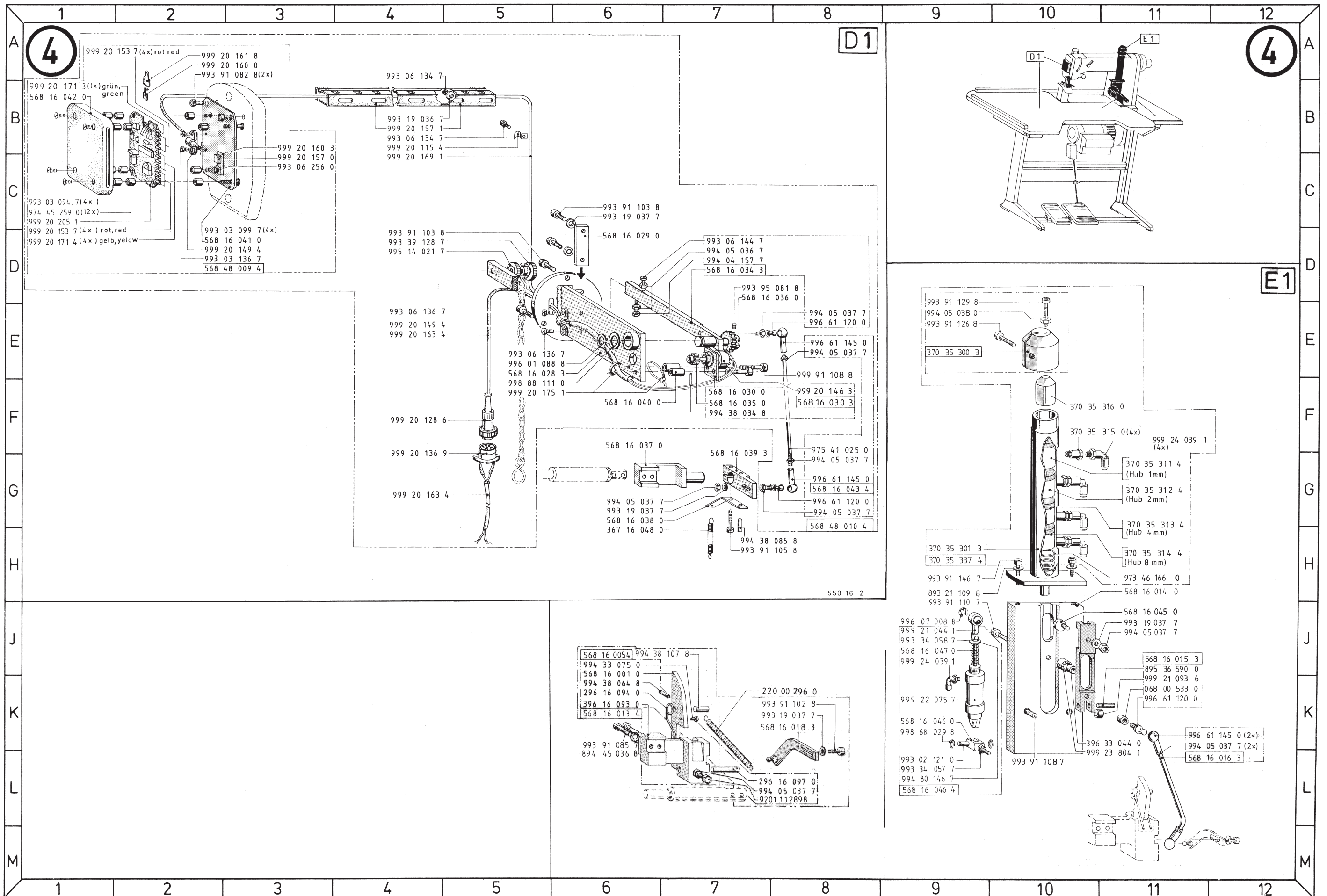

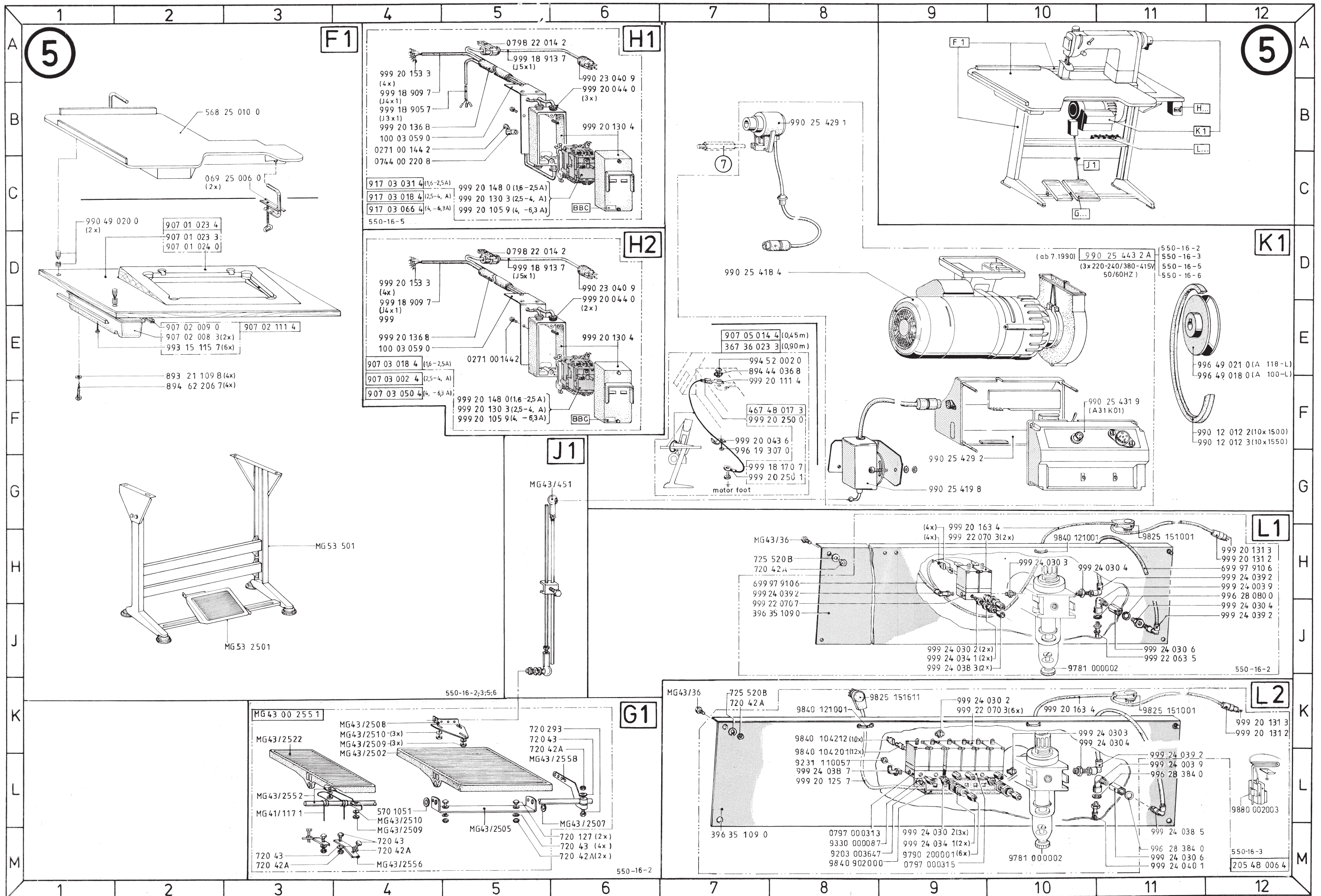

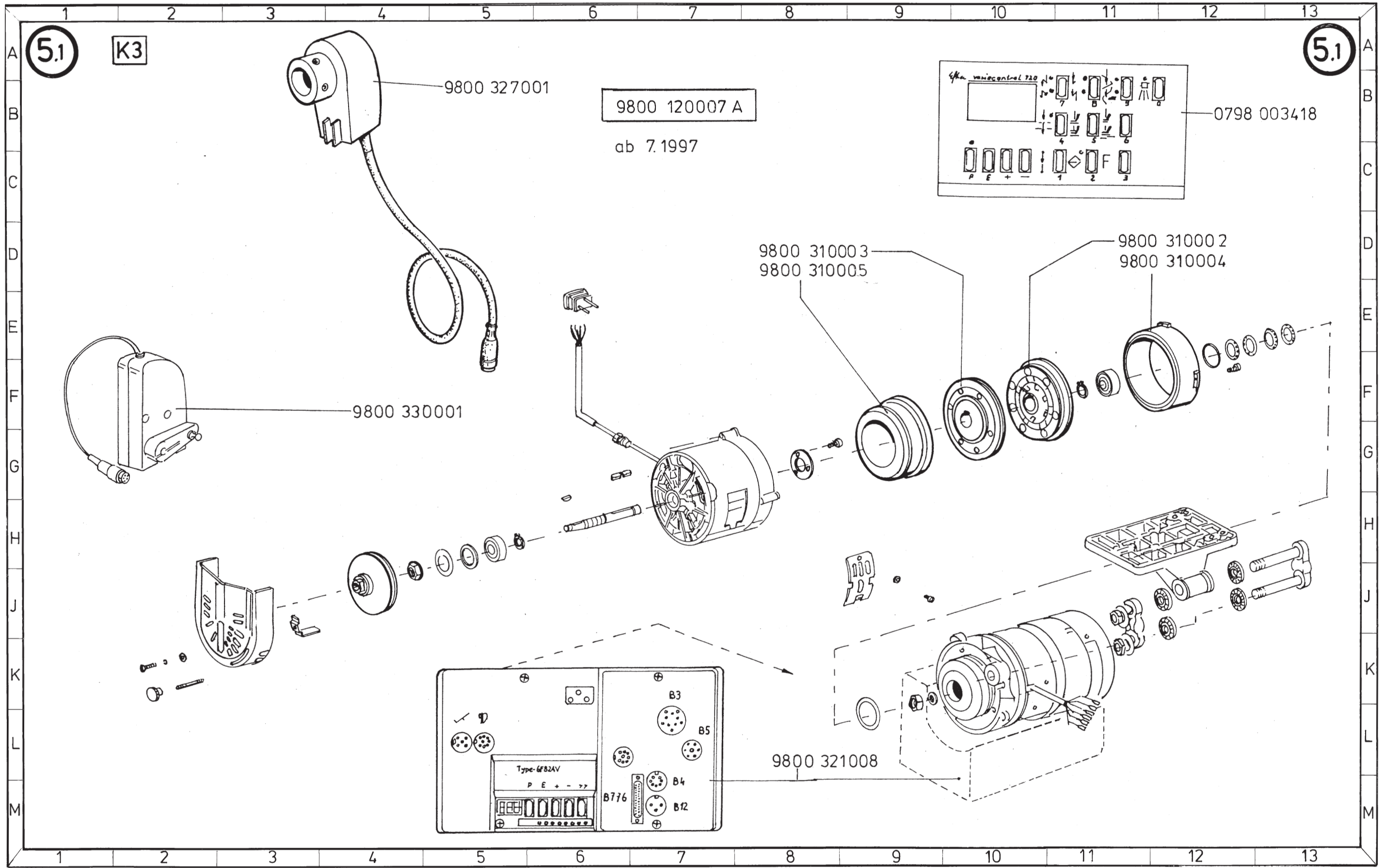

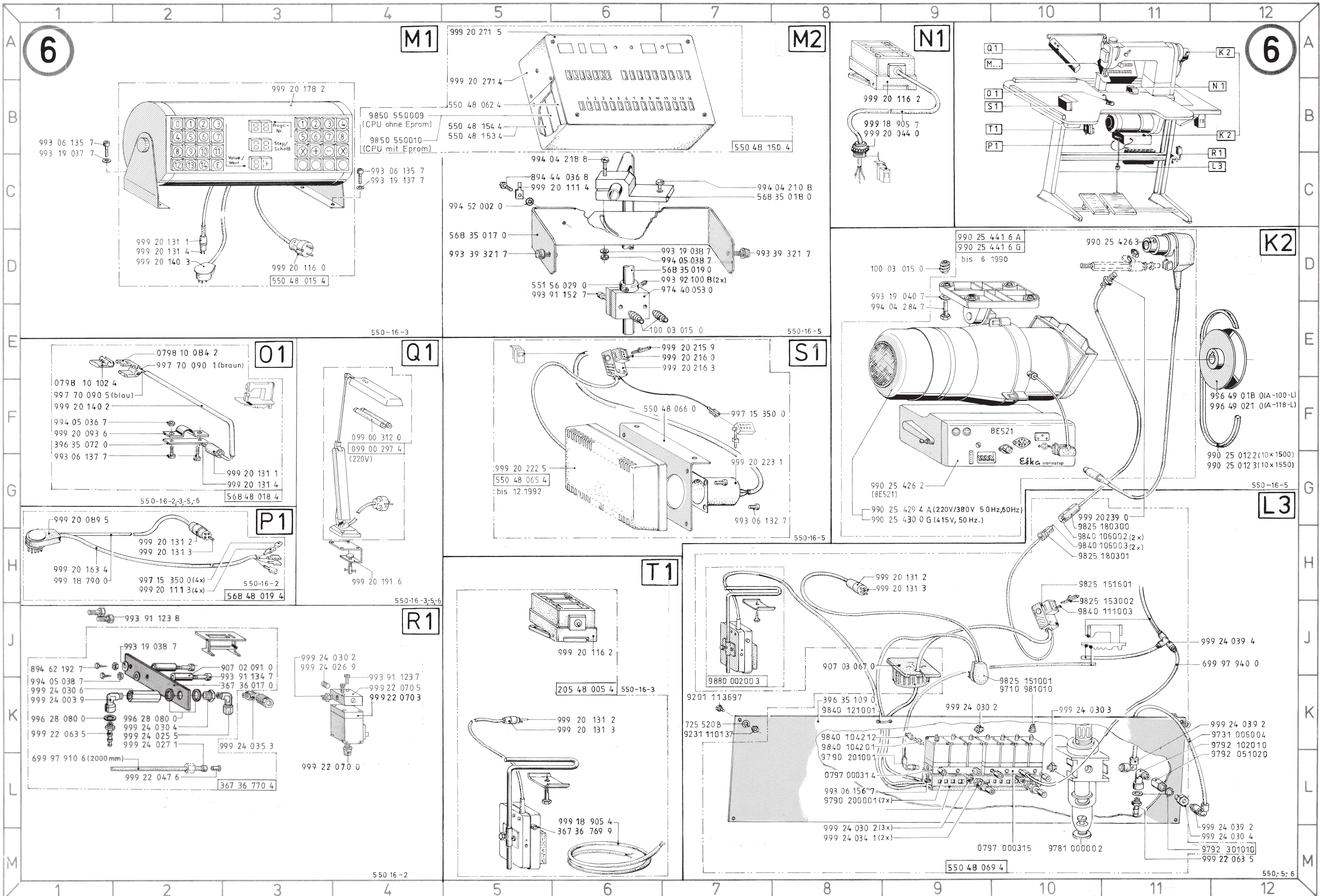

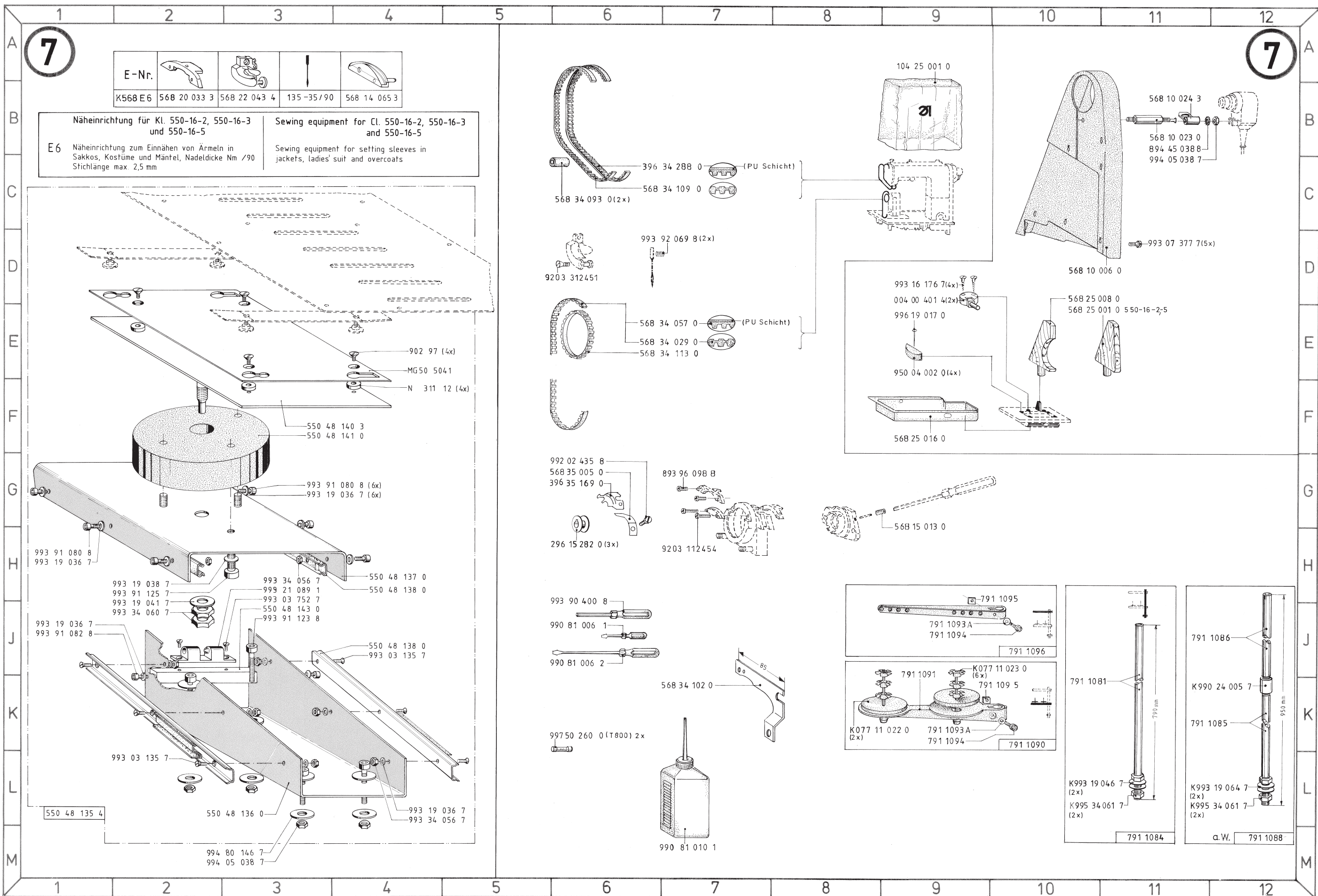

7

7

E-Nr.				
K568 E6	568 20 033 3	568 22 043 4	135-35/90	568 14 065 3

Näheinrichtung für Kl. 550-16-2, 550-16-3 und 550-16-5
 Sewing equipment for Cl. 550-16-2, 550-16-3 and 550-16-5

E6 Näheinrichtung zum Einnähen von Ärmeln in Sakkos, Kostüme und Mäntel, Nadeldicke Nm /90 Stichtlänge max. 2,5 mm
 Sewing equipment for setting sleeves in jackets, ladies' suit and overcoats

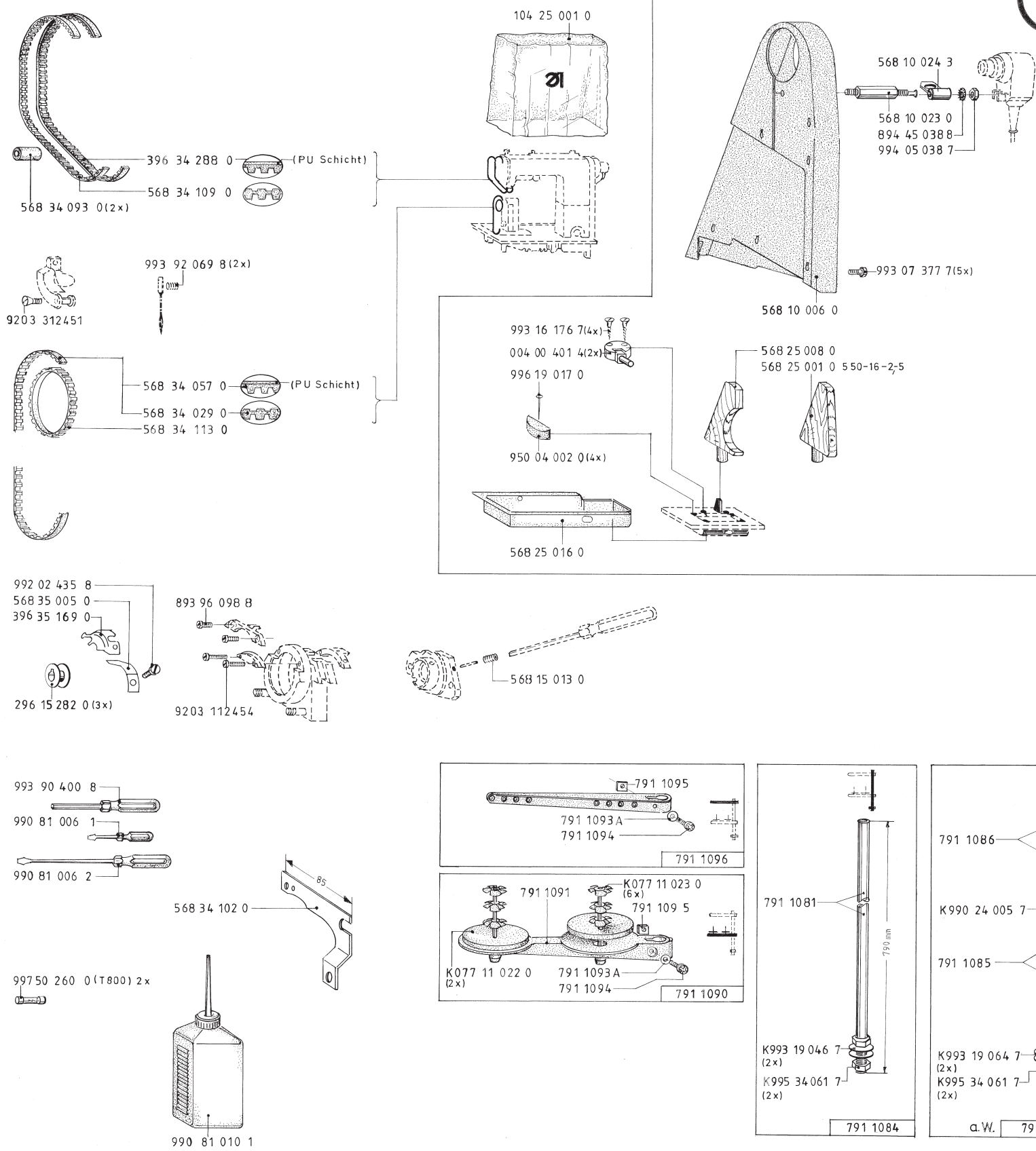
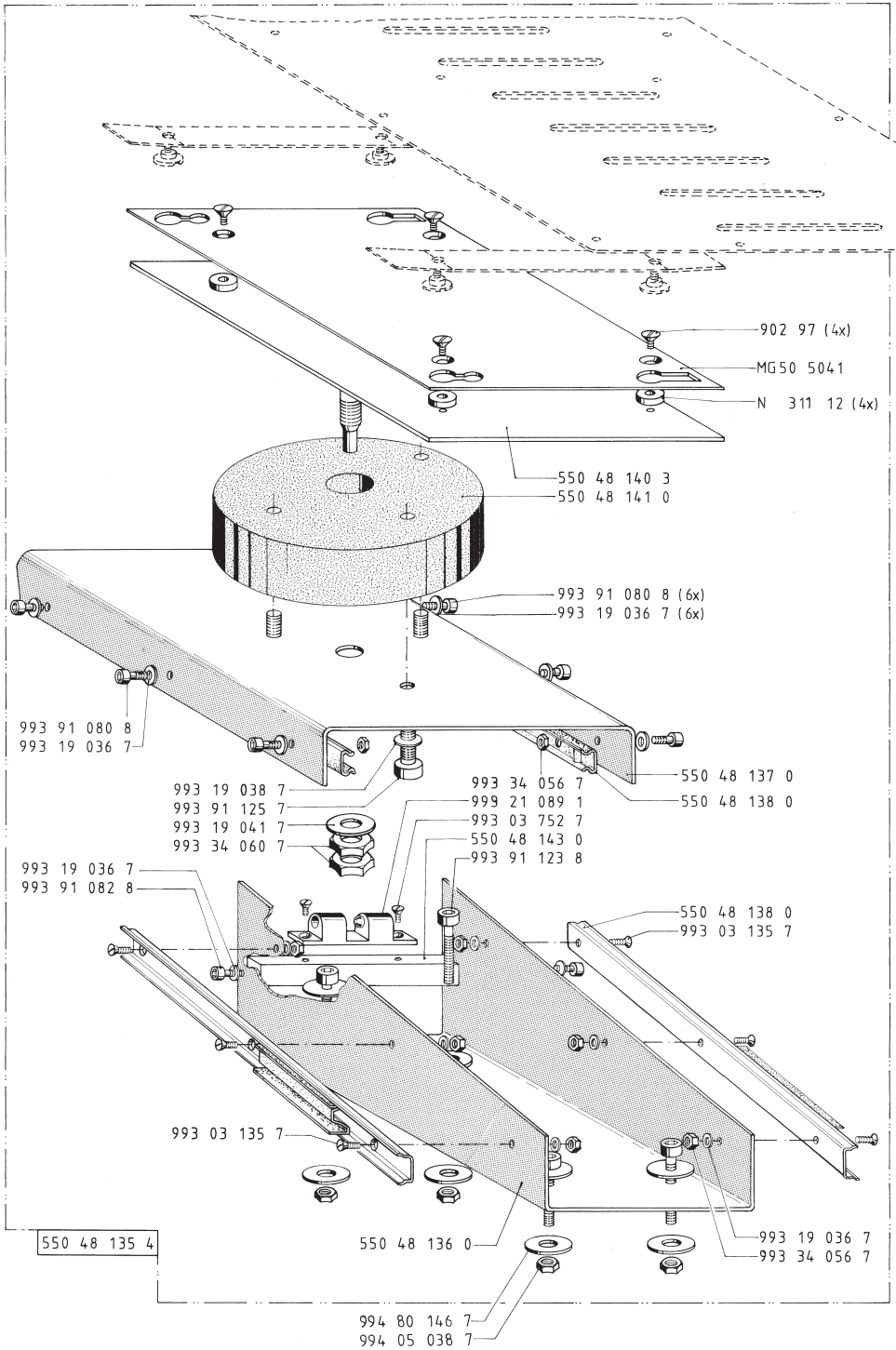

Teile-Nr.	Benennung	Bildtafel	Teile-Nr.	Benennung	Bildtafel	Teile-Nr.	Benennung	Bildtafel	Teile-Nr.	Benennung	Bildtafel
KL. 550-16			K196 00 115 0	FADENANZUGFEDER TENSION SPRING	1D6	K296 00 118 0	HOHLSCHRAUBE HOLLOW SCREW	1D10	K296 31 061 0	WELLE SHAFT	2G9
K004 00 401 4	SCHARNIER	7D9	K196 00 150 0	ABLASSSCHRAUBE DRAIN SCREW	2E8	K296 00 120 0	SCHEIBE DISC	1D11	K296 31 071 0	BUCHSE BUSHING	1K3
K026 13 053 0	DRUCKFEDER PRESSURE SPRING	1C5	K196 00 198 3	STIRNRAD WHEEL	2H5	K296 00 121 0	OELSCHLAUCH OIL HOSE	1D11	K296 31 080 0	KLOBEN BLOCK	1L4
K030 00 134 0	FEDER SPRING	1C5 2K8	K196 00 199 3	STIRNRAD WHEEL	2G4	K296 00 131 3	OELSCHRAUBE OIL SCREW	1B11	K296 31 085 0	BOLZEN BOLT	1K4
K037 00 128 0	FADENSCHLEIBE THREAD DISC	1D7 1K8	K205 48 005 4	KNIESCHALTER KNEE SWITCH	6K6	K296 00 136 0	OELROHR OIL PIPE	1D11	K296 31 086 3	ZUGSTANGE PULL ROD	1F1 1F7
K037 00 129 0	SPANNUNGSFEDER TENSION SPRING	1E6	K205 48 006 4	MAGNETVENTIL SOLENOID VALVE	5M12	K296 00 144 0	NIPPEL NIPPLE	2C7 2M3	K296 31 093 3	GELENKSTUECK JOINT PIECE	1F7
K053 00 035 0	SCHEIBE DISC	1G2 1L11	K220 00 296 0	ZUGFEDER SPRING	4K8	K296 00 194 0	BUCHSE BUSHING	2J9	K296 31 096 0	OELSCHLAUCH OIL HOSE	1F8
K067 15 017 0	STOPFEN	1B3 1K6	K221 11 015 0	SCHEIBE DISC	1D7 1K8	K296 00 208 3	LAGER BEARING	1L11	K296 31 098 0	STOPFEN PLUG	1B2 1J7
K067 23 305 0	DRUCKFEDER PRESSURE SPRING	2H3	K221 11 015 4	VORSPANNUNG PRETENSION	1D7 1K8	K296 00 209 0	ACHSE AXLE	1K11	K296 31 099 0	WELLE SHAFT	2F3
K067 32 015 0	DRUCKFEDER PRESSURE SPRING	1F10	K221 11 016 0	BUCHSE BUSHING	1D7 1K8	K296 00 210 0	SPANNROLLE CLAMPING ROLLER	1K11	K296 34 031 3	STELLRING ADJ RING	3C12
K068 00 024 0	FADENANZ.FEDER	1K1				K296 00 210 4	SPANNROLLE CLAMPING ROLLER	1K11	K296 34 032 0	SCHEIBE DISC	3C12
K068 00 533 0	SCHEIBE DISC	4K11				K296 10 003 0	ARMWELLE ARM SHAFT	1G8	K296 35 029 0	BUCHSE BUSHING	1F1 1L11 3D10
K069 12 002 0	STOPFEN	1A2 1J8	K296 00 007 0	GEHAEUSE HOUSING	1H5	K296 10 011 3	STIFT PIN	1J8	K296 35 030 0	STIFT PIN	3L5
K069 25 006 0	ZWINGE CLAMP	5C3	K296 00 008 0	RING RING	1G9 1H7	K296 10 012 0	STUETZE SUPPORT	1J9		9 S MN PB 28 K	
K077 11 022 0	AUFLAGE SUPPORT	7K8	K296 00 009 0	GEHAEUSE HOUSING	1G6	K296 12 005 0	FADENOESE THREAD LOOP	1M5	K367 16 048 0	ZUGFEDER SPRING	4H6
K077 11 023 0	ZENTRIERSTUECK CENTERING PIECE	7J10	K296 00 012 0	GEHAEUSE HOUSING	1G9	K296 13 011 0	FUEHRUNGSSTUECK GUIDE PIECE	1K5	K367 36 013 3	LEITUNG CABLE	
K096 14 195 3	STELLRING ADJ RING	2J8	K296 00 014 0	HUELSE BUSH	1H10	K296 15 001 0	LAGER BEARING	1K11	K367 36 017 0	HALTER	6K3
K096 15 241 3	SCHARNIER	3J1	K296 00 018 0	REGULIERSTUECK REGULAT PIECE	1L8	K296 15 282 0	SPULE BOBBIN	1C8 3G1 7H6	K367 36 023 3	KABEL CABLE	5E7
K096 15 277 0	SP.FEDER	1L1	K296 00 033 0	OELDOCHT OIL WICK	1F3		AL CU MG 2 F 44		K367 36 769 4	KNIESCHALTER KNEE SWITCH	6M6
K096 15 282 0	SPANNUNGSFEDER	1L1	K296 00 034 0	BOLZEN	1F3	K296 16 012 0	STOPFEN PLUG	1C2 2F7 2G10			
K097 00 335 0	SCHRAUBE SCREW	1F4	—BOLT—			K296 16 038 4	BUCHSE BUSHING	2H2	K367 36 769 9	KNIESCHALTER	6K7
K098 00 299 0	DRUCKFEDER PRESSURE SPRING	1D6	K296 00 045 3	KURBEL CRANK	1G4	K296 16 056 3	KURBEL CRANK	2F6	K367 36 770 4	ANSCHL.TEILE K	6L3
K099 00 297 4	LEUCHTE LAMP	6F4	K296 00 048 0	ANLAUFSCHLEIBE DISC	1H3	K296 16 057 3	KURBEL CRANK	2F8	K370 35 300 3	LAGER BEARING	4E9
K099 00 312 0	LEUCHTSTOFFLAMPE	6F4	K296 00 050 0	DOCHT WICK	1K5				K370 35 301 3	ROHR PIPE	4H9
K100 03 015 0	EINSATZ INSERT	6D9 6E7	K296 00 052 0	FADENOESE THREAD LOOP	1G4				K370 35 311 4	VES ZYLINDER CYLINDER	4G11
K100 03 059 0	WINKEL ANGLE	5B4 5E4	K296 00 071 0	OELSCHLAUCH OIL HOSE	1B10	K296 16 067 0	BUCHSE BUSHING	1F7	K370 35 312 4	VES ZYLINDER CYLINDER	4G11
K170 15 061 0	ZUGFEDER	3J9	K296 00 101 0	OELDOCHT OIL WICK	1G5	K296 16 071 0	LAGERBOCK PILLOW BLOCK	2G5	K370 35 313 4	VES ZYLINDER CYLINDER	4G11
K196 00 047 0	FEDER SPRING	1K5	K296 00 114 0	RING RING	1C11	K296 16 079 0	GEWINDEBUCHSE THREADED BUSH	2L8	K370 35 314 4	ZYLINDER CYLINDER	4H11
K196 00 049 0	NADELLAGER NEEDLE BEARING	1G3	K296 00 116 0	NIPPEL NIPPLE	1C10				K370 35 315 0	ANSCHLUSSTUECK	4F10
K196 00 112 0	VERSCHL STOPFEN PLUG	1A2 1J7									

Teile-Nr.	Benennung	Bildtafel	Teile-Nr.	Benennung	Bildtafel	Teile-Nr.	Benennung	Bildtafel	Teile-Nr.	Benennung	Bildtafel
K370 35 316 0	HUELSE BUSH	4F10	K396 12 040 3	NADELSTANGE NEEDLE BAR	1L5	K396 16 055 3	STELLKLOBEN BLOCK	2F4	K396 31 016 0	BUCHSE BUSHING	1L4
K370 35 337 4	ZYLINDER KPL CYLINDER CPL	4H9	K396 12 068 3	GELENK JOINT	1H2	K396 16 059 0	GLEITBOLZEN SLIDE BOLT	2G7	K396 31 022 0	RING RING	1J4
K381 11 004 3	RAENDELMUTTER KNURLED NUT	1E6	K396 13 073 0	GEWINDEBUCHSE	1J5	K396 16 060 0	GLEITSTUECK SLIDE PIECE	2F5	K396 31 026 0	DRUCKFEDER PRESSURE SPRING	1K5
K396 10 003 0	DICHTUNG GASKET	1L3	K396 13 074 0	GEWINDEBUCHSE	1J5	K396 16 061 0	KLOBEN BLOCK	2G6	K396 31 038 3	KLOBEN BLOCK	1L4
K396 10 023 3	VERSCHL SCHEIBE DISC	1H10	K396 13 075 0	REGULIERSCHR.	1H5	K396 16 062 3	MITNEHMER CATCH	2G7	K396 31 045 0	LAGERBOCK PILLOW BLOCK	1F8
K396 10 023 3	VERSCHL SCHEIBE DISC	1H10	K396 13 076 0	KONTERMUTTER	1J5	K396 16 067 0	GEWINDEBUCHSE THREADED BUSH	2G5	K396 31 066 0	KURBEL CRANK	1H3
K396 10 051 0	FADENHEB SCHUTZ PROTECTOR	1H8	K396 13 080 0	ZYLINDER	1L3	K396 16 068 0	ANSCHLAG GUIDE	2F5	K396 31 068 0	KLOBEN BLOCK	1H2
K396 10 051 0	FADENHEB SCHUTZ PROTECTOR	1H8	K396 13 081 0	KOLBEN	1K3	K396 16 069 0	STELLHEBEL LEVER	2H5	K396 31 078 4	LAGERBOCK PILLOW BLOCK	1E8
K396 10 053 0	HALTEBLECH HOLDING PLATE	1J6	K396 13 082 0	DRUCKSTUECK	1K3	K396 16 075 0	FUEHRUNGSSTUECK GUIDE PIECE	2K8	K396 33 044 0	BUCHSE BUSHING	4K10
K396 10 053 0	HALTEBLECH HOLDING PLATE	1J6	K396 13 083 0	GEWINDEBOLZEN	1J3	K396 16 076 0	STELLBOLZEN BOLT	2K8	K396 33 080 0	ZUGFEDER	2F6
K396 10 055 0	LAGERGEHAEUSE	1G10	K396 13 084 0	HALSMUTTER	1K3	K396 16 077 0	KURVE CAM	2K8	K396 33 104 0	GEWINDEBOLZEN THREADED BOLT	1G7
K396 10 055 4	GEHAEUSE HOUSING	1G10	K396 13 085 0	ANSCHLAG	1K1	K396 16 078 3	STELLSCHEIBE ADJ DISC	2L9	K396 34 110 0	SCHRAUBE SCREW	3B10
K396 10 055 4	GEHAEUSE HOUSING	1G10	K396 13 086 0	KNOPF	1K1	K396 16 093 0	KURBEL CRANK	4K6	K396 34 119 0	STOFFDR STANGE FOOT BAR	1M4
K396 10 061 0	ROHR PIPE	1J6	K396 14 005 0	DICHTSCHEIBE GASKET	2A6 2A9	K396 17 006 0	HUELSE BUSH	1F8	K396 34 122 3	KURBEL CRANK	3J4 3K6
K396 10 061 0	ROHR PIPE	1J6	K396 14 009 3	ROHR PIPE	2C7	K396 17 008 0	DRUCKFEDER PRESSURE SPRING	1F8	K396 34 160 0	ZUGFEDER SPRING	3K5
K396 10 088 0	FINGERSCHUTZ FINGER GUARD	1J7	K396 14 026 9	STOPFEN	1B2 2G10	K396 17 011 3	AUSLOESEHEBEL RELEASE LEVER	1D8	K396 34 258 0	DREHFEDER SPRING	1E5
K396 10 088 0	FINGERSCHUTZ FINGER GUARD	1J7	K396 14 124 0	DECKEL	2A9	K396 17 014 0	KLEMMFEDER CLAMPING SPRING	1D8	K396 34 288 0	ZAHNRIEMEN BELT	3C8 3C9 7C7
K396 10 091 3	VENTILGEHAEUSE VALVE CASE	1F6	K396 15 016 0	ANTRIEBSWELLE DRIVING SHAFT	2J1 2J7 2J9	K396 17 016 0	FADENFUEHRUNG THREAD GUIDE	1D8 1K8	K396 34 302 0	EXZENTERBOLZEN ECCENTR BOLT	3C8
K396 10 091 3	VENTILGEHAEUSE VALVE CASE	1F6	K396 15 016 0	ANTRIEBSWELLE DRIVING SHAFT	2J1 2J7 2J9	K396 17 017 0	GEWINDEBOLZEN THREADED BOLT	1D7 1K8	K396 34 306 0	BUNDBUCHSE	1D4
K396 10 091 4	VENTILGEHAEUSE VALVE CASE	1F6	K396 15 079 0	FADENFUEHRUNG THREAD GUIDE	3K1	K396 17 022 0	BUCHSE BUSHING	1D10	K396 34 307 3	STELLSCHEIBE ADJ DISC	1D5
K396 10 091 4	VENTILGEHAEUSE VALVE CASE	1F6	K396 15 079 0	FADENFUEHRUNG THREAD GUIDE	3K1	K396 17 025 3	SPULERBOCK WINDER BLOCK	1E8	K396 34 311 0	DISTANZSCHEIBE DISTANCE DISC	1E5
K396 10 094 0	SCHRAUBE SCREW	1F6	K396 15 080 0	SCHRAUBE SCREW	1L1 3K1	K396 17 026 0	ARM ARM	1F10	K396 34 312 0	EXZENTERBOLZEN ECCENTR BOLT	1E5 1D6
K396 10 094 0	SCHRAUBE SCREW	1F6	K396 15 080 0	SCHRAUBE SCREW	1L1 3K1	K396 17 027 0	KLOBEN BLOCK	1E8	K396 35 066 0	HUELSE BUSH	2L4
K396 10 096 0	ANSATZBUCHSE	1J2	K396 15 081 4	GREIFER HOOK	3G2 3M2	K396 17 028 3	NOCKEN CAM	1F8	K396 35 068 3	STEUERKURVE CONTROL CAM	2J1
K396 10 103 0	LEITBLECH GUIDE PLATE	1L5	K396 15 082 4	SPULENGEHAEUSE BOBBIN CASE	1M1 3J2	K396 17 033 3	SPULERWELLE WINDER SHAFT	1D9	K396 35 072 0	LASCHE SHACKLE	2J5 6F1
K396 10 103 0	LEITBLECH GUIDE PLATE	1L5	K396 15 082 4	SPULENGEHAEUSE BOBBIN CASE	1M1 3J2	K396 24 011 0	BOLZEN BOLT	3D9	K396 35 109 0	PLATTE PLATE	5J8 5M7 6K8
K396 10 117 0	SCHUTZGEHAUSE	1H6	K396 15 084 0	FADENSCHUTZSTUECK	3L2	K396 31 008 0	STOPFEN PLUG	1B2 1C3 2F2	K396 35 122 9	WARTUNGSEINHEIT CONDITION UNIT	5J10 5M10 6K10
K396 10 118 0	KOPFDECKEL	1J2	K396 15 085 0	BREMSFEDER BRAKE SPRING	1L1						
K396 10 118 4	KOPFDECKEL	1L3	K396 15 086 0	SENKSCHRAUBE SCREW	3J1						
K396 11 001 0	BOLZEN BOLT	1D5	K396 15 087 0	GEWINDESTIFT THREADED PIN	3L1						
K396 11 001 0	BOLZEN BOLT	1D5	K396 15 087 0	GEWINDESTIFT THREADED PIN	3L1						
K396 11 035 0	KLEMMSTUECK CLAMP PIECE	1L8	K396 15 088 0	STIFT 13,8X35	1L1						
K396 11 035 0	KLEMMSTUECK CLAMP PIECE	1L8	K396 15 088 0	STIFT 13,8X35	1L1						
K396 11 036 0	FADENFUEHRUNG THREAD GUIDE	1J8	K396 16 016 4	KURBEL CRANK	2H6						
K396 11 036 0	FADENFUEHRUNG THREAD GUIDE	1J8	K396 16 016 4	KURBEL CRANK	2H6						
K396 11 047 0	DRUCKFEDER PRESSURE SPRING	1D7 1L8	K396 16 017 4	KURBEL CRANK	2H9						
K396 11 047 0	DRUCKFEDER PRESSURE SPRING	1D7 1L8	K396 16 017 4	KURBEL CRANK	2H9						
K396 11 172 0	SPANN.GEHAEUSE	1B4	K396 16 022 3	EXZENTER ECCENTRIC	2H8						
K396 11 172 0	SPANN.GEHAEUSE	1B4	K396 16 022 3	EXZENTER ECCENTRIC	2H8						
K396 11 173 0	BUCHSE	1C5	K396 16 023 0	DISTANZSCHEIBE DISTANCE DISC	2J8						
K396 11 173 0	BUCHSE	1C5	K396 16 023 0	DISTANZSCHEIBE DISTANCE DISC	2J8						
K396 11 174 0	KOLBEN	1C5	K396 16 034 3	WELLE SHAFT	2G10						
K396 11 174 0	KOLBEN	1C5	K396 16 034 3	WELLE SHAFT	2G10						
K396 11 175 0	SPANNUNGSBUCHSE	1C5	K396 16 035 3	STELLHEBEL LEVER	2H9						
K396 11 175 0	SPANNUNGSBUCHSE	1C5	K396 16 035 3	STELLHEBEL LEVER	2H9						
K396 11 183 4	FADENSPANNUNG K THREAD TENSION	1B6	K396 16 036 0	BUCHSE BUSHING	2G9						
K396 11 183 4	FADENSPANNUNG K THREAD TENSION	1B6	K396 16 036 0	BUCHSE BUSHING	2G9						
K396 12 027 4	KURBEL CRANK	1H4	K396 16 042 0	BUCHSE BUSHING	2F3						
K396 12 027 4	KURBEL CRANK	1H4	K396 16 042 0	BUCHSE BUSHING	2F3						
K396 12 028 3	FADENHEBEL THREADLEVER	1G3									
K396 12 028 3	FADENHEBEL THREADLEVER	1G3									
K396 12 037 0	BUCHSE BUSHING	1K5									
K396 12 037 0	BUCHSE BUSHING	1K5									
K396 12 039 0	BUCHSE BUSHING	1J5									
K396 12 039 0	BUCHSE BUSHING	1J5									

Teile-Nr.	Benennung	Bildtafel	Teile-Nr.	Benennung	Bildtafel	Teile-Nr.	Benennung	Bildtafel	Teile-Nr.	Benennung	Bildtafel
K396 35 168 0	LAGERBOCK PILLOW BLOCK	2L1	K568 10 014 3	ARMDECKEL ARM COVER	1E8	K568 15 007 0	ZAHNRIEMEN BELT	2K9	K568 16 029 0	LASCHE SHACKLE	4D6
K396 35 169 0	MESSER KNIFE	2D2 7G6	K568 10 014 4	ARMDECKEL KPL ARM COVER CPL	1E8	K568 15 010 0	SPEZIALMUTTER NUT	3G6	K568 16 030 0	HALTER HOLDER	4F7
K396 35 171 3	SEGMENT SEGMENT	2M3	K568 10 017 0	LAGERBUCHSE BEARING BUSH	1H6	K568 15 013 0	SCHRAUBE SCREW	3F6 7G9	K568 16 030 3	POTENTIOMETER POTENTIOMETER	4F8
K396 35 172 0	ROLLE	2M3	K568 10 020 4	ARMWELLE ARM SHAFT	1F4	K568 15 014 0	HALTER HOLDER	3F2	K568 16 034 3	HEBEL LEVER	4D7
K396 35 173 0	GABELKOPF FORK HEAD	2L2	K568 10 023 0	BOLZEN BOLT	7B11	K568 15 015 0	ZAHNRIEMEN BELT	3G7	K568 16 035 0	ZAHNRAD COG WHEEL	4F7
K430 27 736 0	SCHEIBE DISC	1F10	K568 10 024 3	HALTER HOLDER	7B11	K568 15 018 0	EXZENTERRING ECCENTR RING	2J3	K568 16 036 0	ZAHNRAD COG WHEEL	4D7
K467 11 022 0	SPANNSCHEIBE TENSION WASHER	1D6	K568 10 025 0	OELFALLROHR	1C10	K568 15 018 4	EXZENTERRINGKPL ECCENTR RING	2H3	K568 16 037 0	HEBEL LEVER	4F6
K467 48 017 3	KABEL, ERDUNG ERDUNG	5F8	K568 10 025 4	OELFALLROHR	1C10	K568 15 019 3	EXZENTER ECCENTRIC	2J3	K568 16 038 0	HALTER HOLDER	4G6
K504 33 092 0	BOLZEN BOLT	2L2	K568 11 003 0	FADENFUEHRUNG	1L2	K568 15 020 0	KLOBEN BLOCK	2H3	K568 16 039 3	KLOBEN BLOCK	4G7
K550 48 015 4	PROGRAMMBOX PROGRAMME BOX	6D3	K568 14 001 0	GRUNDPLATTE BASE PLATE	2C10	K568 15 021 0	DECKBLECH COVER PLATE	2H3	K568 16 040 0	DISTANZHUELSE DISTANCE SLEEVE	4F6
K550 48 059 4	PLATINE PLATE	6B5	K568 14 002 0	STAENDER STAND		K568 15 035 3	AUFLAGE SUPPORT	3E6	K568 16 041 0	PLATTE PLATE	4D3
K550 48 060 4	PLATINE PLATE	6B5	K568 14 005 0	LAGERPLATTE BEARING PLATE	3K4	K568 15 040 0	GREIFERWELLE HOOK SHAFT	3F7	K568 16 042 0	KAPPE CAP	4B1
K550 48 062 4	PLATINE PLATE	6B5	K568 14 014 0	OELROHR OIL PIPE	2C9	K568 15 041 3	GREIFERWELLEKPL HOOK SHAFT CPL	3F7	K568 16 043 4	ZUGSTANGE PULL ROD	4G8
K550 48 064 4	BEDIENPULT CONTROL PANEL	6B7	K568 14 018 0	SCHEIBE DISC	3G5	K568 15 043 3	KAPPE CAP	3K9	K568 16 044 0	ZAPFEN STUD	3J4
K550 48 065 4	NETZTEIL MAINS UNIT	6G5	K568 14 019 0	ABDECKKAPPE COVER CAP	3K9	K568 15 044 0	ABWEISER DEFLECTOR	3E8	K568 16 045 0	EXZENTER ECCENTRIC	4J11
K550 48 066 0	WINKEL ANGLE	6F7	K568 14 021 0	OELSTANDSANZEIG	2B8	K568 15 053 0	BUCHSE	2G2	K568 16 046 0	HALTER HOLDER	4K9
K550 48 069 4	VENTILEINH.200- 200-1	6M9	K568 14 029 0	LASCHE SHACKLE	3H7	K568 15 054 0	GREIFERW.LAGER	3F5	K568 16 046 4	ZYLINDER CYLINDER	4L9
K550 48 071 3	SCHALTAFEL,200 550-16-5	6A5	K568 14 030 0	DECKBLECH COVER PLATE	3K9	K568 15 054 4	LAGER KPL BEARING CPL	3G7	K568 16 047 0	FEDER SPRING	4J9
K551 56 029 0	STELLRING ADJ RING	6D6	K568 14 042 0	OELSTAB OIL DIPSTICK	2C9	K568 15 056 0	NIPPEL	2C6 2G3 3G5	K568 20 009 3	STICHPLATTE	3F4 7B2
K568 10 001 0	ARM ARM	1M8	K568 14 043 0	FILZSCHEIBE FELT DISC	2H8	K568 15 066 0	EXZENTERBOLZEN	3H7	K568 22 006 0	ROLLE	3H8
K568 10 004 0	OELROHR OIL PIPE	1D11	K568 14 045 3	ABDECKKAPPE COVER CAP	3K9	K568 15 067 0	ROLLE	3H7	K569 22 014 0	FINGERSCHUTZ	3G9
K568 10 005 4	OELROHR KPL OIL PIPE CPL	1B11	K568 14 047 3	KOPF HEAD	3G4	K568 15 068 4	SPANNROLLE K	3H7	K568 22 030 0	FUSSOBERTEIL	3H9
K568 10 006 0	RIEMENSCHUTZ BELT GUARD	7D10	K568 14 048 0	FUEHRUNGSSTUECK GUIDE PIECE	3F2	K568 16 001 0	KONTAKTHEBEL CONTACT LEVER	4J6	K568 22 031 3	ROLLENHEBEL	3G10
K568 10 008 0	HANDRAD HANDWHEEL KUNSTSTOFF	1G12	K568 14 053 0	HALTER HOLDER	3J6	K568 16 005 4	STICHST.KURBEL		K568 22 043 3	DRUECKERFUSS	3G8
K568 10 008 4	HANDRAD HANDWHEEL	1G12	K568 14 054 0	FUSS	2E6	K568 16 008 0	BUCHSE BUSHING	2F9	K568 22 043 4	DRUECKERFUSS	3J8 7B3
K568 10 011 0	HALTEBLECH	1L6	K568 14 055 0	SCHUTZBUEGEL	2F6	K568 16 013 4	STICHST.KURBEL	4K6	K568 22 044 0	ROLLE	3G8
			K568 14 056 0	BUCHSE BUSHING	3J6	K568 16 014 0	TRAEGER CARRIER	4H11			
			K568 14 061 0	SAEULE	3H4	K568 16 015 3	SCHIEBER SLIDE	4J11			
			K568 15 002 0	ANTRIEBSWELLE DRIVING SHAFT	2G2	K568 16 016 3	ZUGSTANGE PULL ROD	4L11			
			K568 15 003 3	RAD WHEEL	2G1	K568 16 018 3	ZUGARM	4K8	K568 24 023 0	ANSCHLAG GUIDE	3J12
			K568 15 005 3	ZAHNRIEMENRAD BELT PULLEY	1H8	K568 16 023 0	FILZSTOPFEN FELT PLUG	2F2			
			K568 15 006 3	ZAHNRIEMENRAD BELT PULLEY	2J10	K568 16 024 0	BUCHSE BUSHING	2F4			
						K568 16 028 3	HEBEL LEVER	4E5			

Teile-Nr.	Benennung	Bildtafel	Teile-Nr.	Benennung	Bildtafel	Teile-Nr.	Benennung	Bildtafel	Teile-Nr.	Benennung	Bildtafel
K568 25 001 0	OBerteilStuetze SUPPORT	7E10	K568 34 029 0	Zahnriemen BELT	3H3 7E7	K568 35 017 0	HALTER HOLDER	6D5			
K568 25 008 0	Stuetze SUPPORT	7D10	K568 34 038 3	Lagerbock Pillow Block	3D12	K568 35 018 0	Kloben Block	6C8	K893 06 674 7	ZYL.SCHR.	2C1
K568 25 010 0	Arbeitsplatte Working Plate 1070 X 750 X 102	5B3	K568 34 038 4	Lagerbock Pillow Block	3E12	K568 35 019 0	ROHR PIPE	6D7	K893 21 109 8	FEDERRING SPRING RING	3H4 4H9
K568 25 016 0	Oelfangblech Oil Drip Sheet	7F9	K568 34 039 0	Distanzbuchse Distance Bush	3B10	K568 35 021 0	LAGERRING BEARING RING	2D2	K893 23 045 8	FEDERSCHEIBE SPRING DISC	3M9
K568 25 760 0	MZ-GRUNDPLATTE		K568 34 040 0	Antriebshebel LEVER	3L6	K568 35 022 0	LAGERPLATTE BEARING PLATE	2D3	K893 23 049 8	FEDERSCHEIBE SPRING DISC	2L8
K568 31 004 3	Lagergehäuse	1G7	K568 34 040 4	Antriebshebel LEVER	3M6	K568 35 023 0	Fuehrung GUIDE	2E2	K893 97 098 6	FL.KOPFSCHR. M4X8	2L9
K568 31 005 3	HUBEXZENTER STROKECAM	1F6	K568 34 045 3	Lagerbock Pillow Block	3C11	K568 35 024 3	LAGERPLATTE V	2L4	K893 97 098 7	SCHRAUBE SCREW	3H7
K568 31 005 4	HUBEXZENTER STROKECAM	1F6	K568 34 046 3	Kurbel CRANK	3C10	K568 35 024 4	LAGERPLATTE KPL BEARING PLATE	2L4	K893 97 098 8	ZAHNSCHEIBE TOOTHED WASHER	6C6
K568 31 006 4	Winkelhebel LEVER	1L4	K568 34 047 3	Stellkloben Block	3B9	K568 35 026 0	VENTILTRAEGER	2K3	K894 44 036 8	FACHERSCHEIBE DISC	1K3 3D11 3L5
K568 31 007 0	HEBEL LEVER	1J4	K568 34 048 3	Lagerbuchse BEARING BUSH	3B9	K568 35 027 4	ZUGSTANGE KPL PULL ROD CPL	2E2	K894 45 034 8	FACHERSCHEIBE DISC	2H5 2L4 4L6
K568 31 008 0	Gelenkstueck Joint Piece	1J4	K568 34 049 3	Bremse BRAKE	3K5	K568 35 028 0	ZUGSTG.OBERT.	2E2	K894 45 036 8	FACHERSCHEIBE DISC	7B11
K568 31 009 0	Zugstange PULL ROD	1J4	K568 34 050 3	Lagerbock Pillow Block	1D6	K568 35 029 3	ZUGST UNTERTEIL ROD LOWER PART	2E2	K894 45 038 8	FACHERSCHEIBE DISC	1F7
K568 31 010 0	Puffer Buffer	1J4	K568 34 053 0	Buchse Bushing	1D6	K568 35 031 0	LASCHE	2E2	K894 45 066 8	FACHERSCHEIBE DISC	6J1
K568 31 017 0	Lagerbuchse BEARING BUSH	1J9	K568 34 054 0	Piston PISTON	1C5	K568 48 009 4	Anzeige Indicator	4D3	K894 62 192 7	6KT.BLECHSCHR. B6,3X16	6J1
K568 31 020 0	WELLE	1H5 1H9	K568 34 055 0	Einstellknopf	1C5	K568 48 010 4	ELEKTR.RAFFEINR	4H8	K895 36 101 0	ZYL STIFT CYLIND PIN	2M3
K568 33 031 0	DECKEL COVER		K568 34 057 0	Zahnformriemen	3H3 7E7	K568 48 018 4	KABEL,ADAPTER K FAP F.550-16-3,-5	2K3 6G3	K895 36 118 0	ZYL STIFT CYLIND PIN	3J6
K568 34 001 0	Kupplungswelle Coupling Shaft	3D9	K568 34 059 0	KAPPE CAP	3C6	K568 48 019 4	LEITUNG K MAGNETV.FA/FS/FLP	6H3	K895 36 137 0	ZYL STIFT CYLIND PIN	1D5
K568 34 002 0	Scheibe DISC	3C10 3K6	K568 34 060 0	Distanzbolzen BOLT	3C7	K570 00 105 1	SCHEIBE 14,00 VZI	5L4	K895 36 590 0	STIFT PIN	4J11
K568 34 006 0	Antriebshebel LEVER	3E11	K568 34 086 0	Platte Plate	3D9	K699 97 910 0	SCHLAUCH 1B9 1C9 1F9 1J6 2H4 3G6		K895 42 017 8	SENKSCHRAUBE SCREW	1J1
K568 34 006 4	Antriebshebel LEVER	3E11	K568 34 086 4	Platte V	3E9	K699 97 910 4	SCHLAUCH 1B10		K907 01 023 3	TISCHPLATTE 1060 X 550 X 40	5D2
K568 34 009 0	Scheibe DISC	1C5	K568 34 087 3	Schubstange CONNECTING ROD	3E7	K699 97 910 6	SCHLAUCH 4LWX1PE 6K12-6L1		K907 01 023 4	TISCHPLATTE TABLE TOP	5C2
K568 34 010 0	Zugstange PULL ROD	1H11	K568 34 088 0	Gelenk JOINT	3C7	K699 97 926 5	SCHLAUCH 1,6LWX0,8	2E11 3G6	K907 01 024 0	SOCKEL BASE	5D2
K568 34 010 4	Zugstange PULL ROD	1J11	K568 34 093 0	Gleitstueck SLIDE PIECE	3E8 7C6	K699 97 940 0	SCHLAUCH 2L1 6J12				
K568 34 011 0	Kurbel CRANK	1H11 1M11	K568 34 094 0	Gleitstueck SLIDE PIECE	3C8	K699 98 925 0	RUNDSCHNUR 2B6				
K568 34 012 3	Huelse BUSH	3K7	K568 34 095 4	Lagerbock KPL PillowBlock CPL	1C6	K699 99 158 3	DOCHT 1C11				
K568 34 014 0	Achse AXLE	3K7	K568 34 099 3	Zahnriemenrad BELT PULLEY	3B8	K699 99 158 5	OELDOCHT RD4 1H7				
K568 34 023 0	Abdeckkappe Cover Cap	3K9	K568 34 101 0	Zugstange 3D10 3L6		K767 48 007 0	GABELCRIMPkont. 6J10				
			K568 34 109 0	Zahnriemen BELT	3C8 3G8 7C7		EINZELTEIL V.BAND				
			K568 34 113 0	Zahnrad COG WHEEL	3F2 7E7	K798 10 084 2	STECKHUELSE 2K6				
			K568 35 005 0	Gegenmesser COUNTERKNIFE X 210 CR 12	2C3 7G6	K798 10 102 4	ISOLIERHUELSE 2K6				
						K801 13 010 2	ZAPFEN STUD 1M11				
						K802 51 044 0	HUELSE BUSH 3H4				
						K802 51 169 0	Buchse Bushing 1D4				
						K893 03 724 6	Senkschraube SCREW M3X6 2C2				
						K893 03 765 7	Senkschr. 3G4				

Teile-Nr.	Benennung	Bildtafel	Teile-Nr.	Benennung	Bildtafel	Teile-Nr.	Benennung	Bildtafel	Teile-Nr.	Benennung	Bildtafel
K907 02 008 3	SCHUBKASTEN DRAWER KUNSTSTOFF	5E2				K992 00 244 0	GEWINDESTIFT THREADED PIN NR.28X4	2H8 2J8	K992 01 727 7	MUTTER NUT NR.40	1J6
K907 02 009 0	FUEHRUNGSLEISTE GUIDE BAR	5E2	K990 25 418 4	MOTOR MOTOR QD554M/14	5D7	K992 00 281 7	SCHRAUBE SCREW NR.88X6,	1H2	K992 01 758 0	SCHRAUBE SCREW NR.99X10,0	1H4
K907 02 091 0	HUELSE	6J3							K992 01 983 0	MUTTER NUT M4	2G5
K907 03 002 4	SCHUTZSCHALTER SWITCH 2,5 -4,0A	5F4				K992 00 333 8	SCHRAUBE SCREW NR.53X3	3G9 3H8 7D6	K992 01 985 6	SCHRAUBE SCREW M4	3K12
K907 03 050 4	SCHUTZSCH.KPL. 4,0-6,3A	5F4	K990 25 419 8	SOLLWERTGEBER SPEED SELECTOR 07.000.012	5G9	K992 00 422 0	GEWINDESTIFT THREADED PIN NR.28X 13	1F11 1G12	K992 01 998 0	SCHRAUBE SCREW	3K2 3L2
K907 03 067 0	STOPFEN PLUG	6J8	K990 25 426 2	STEUERKASTEN CONTROL UNIT 8E521	6G9	K992 00 674 6	SENKSCHRAUBE SCREW NR.54X5	1L8	K992 02 230 7	MUTTER NUT NR.40	1L8
K907 05 014 4	TEILESATZ ERD.K	5D7	K990 25 426 3	POSITIONSGEBER SYNCHRONIZER P4/4	6K11	K992 00 720 0	GEWINDESTIFT THREADED PIN NR.14X 4,5	1C3 2G4	K992 02 361 0	SCHRAUBE SCREW NR.87	1G2
K917 03 018 4	SCHUTZSCHALTER SWITCH 2,5 -4,0A	5C4 5E4	K990 25 429 4	MOTOR MOTOR VD554 NORM.KUPPL.	6G9	K992 00 742 7	MUTTER NUT NR.18 2,5	2G5	K992 02 408 0	SPEZIALSCHRAUBE SPECIAL SCREW M3	3D10 3L6
K917 03 031 4	SCHUTZSCH.KPL. 1,6-2,5A	5C4	K990 25 430 0	NAEHM.MOTOR VD554	6G9	K992 00 859 0	LI.ZYL.SCHR. NR.86X3	1H8	K992 02 435 8	SCHRAUBE SCREW M4X2,8	2D3 3K9 7G6
K917 03 066 4	SCHUTZSCH.KPL. 4,0-6,3A	5C5	K990 25 432 0	ANAHEM.MOTOR	5D10	K992 00 859 7	LI.ZYL.SCHR.	3J6	K992 02 461 8	ANSATZSCHR.	3H9
K950 04 002 0	GUMMIAUFLAGE RUBBER COADING	7E9	K990 25 432 0	OGNAEHM.MOTOR	5D10	K992 00 992 0	SCHRAUBE SCREW NR.13	3K1	K993 02 009 0	ZYL.STIFT 0,8M 6X8	3F6
			K990 25 441 6	ANAHEM.MOTOR	6D10						
			K990 25 441 6	6GNAEHM.MOTOR	6D10						
			K990 28 003 8	KABELOESE 4 X1,5							
			K990 49 020 0	GEWINDEENSAT	5D1						
K973 43 099 0	SCHEIBE DISC	3B8				K992 00 993 0	SENKSCHRAUBE SCREW NR.47X2	1L1	K993 02 121 0	STIFT PIN 5 M 6X24	4L9
K973 46 166 0	DRUCKFEDER PRESSURE SPRING DRAHT 1,3 DIN 2076	4H11	K990 81 006 1	SCHRAUBENDREHER SCREWDRIWER A 0,4X 2,5	7J6	K992 01 243 0	GEWINDESTIFT THREADED PIN NR.18X 7,5	1F6 1H4 1L11 2H5 2J4	K993 03 094 7	SENKSCHRAUBE SCREW M3X6	1C5 1L6 4C1
K973 46 269 0	SCHEIBE DISC	3F4	K990 81 006 2	SCHRAUBENDREHER SCREWDRIWER A 0,8X 5,5	7J6	K992 01 265 7	SCHRAUBE SCREW NR.28X6,5	2C9	K993 03 099 7	SENKSCHRAUBE SCREW M3X18	4D3
K973 51 142 0	STIFT PIN	3E9	K990 81 010 1	NAEHM OEL 250GR OIL 250 GRAMS 250GR.E.SP-NK10	7M7	K992 01 368 7	AUSLOESESTIFT RELEASE PIN 1,80X28,8	1C5	K993 03 134 7	SENKSCHRAUBE SCREW M4X6	3F4
K974 40 053 0	KLOBEN BLOCK	6D7	K990 92 097 6	NADEL	1M5	K992 01 491 0	GEWINDESTIFT THREADED PIN NR.40X 2,8	1B11	K993 03 136 7	SENKSCHRAUBE SCREW M4X10	1F7 4D3
K974 45 259 0	DISTANZSTUECK DISTANCE PIECE	4C1	K992 00 016 7	SCHRAUBE SCREW NR.28X13	2K7	K992 01 497 0	GEWINDESTIFT THREADED PIN NR28X15X21	1F12	K993 03 138 7	SENKSCHRAUBE SCREW M4X16	2L1 3D7
K975 41 025 0	STANGE ROD	4F8	K992 00 032 7	SENKSCHRAUBE SCREW NR.40X10	1J8	K992 01 506 0	SENKSCHRAUBE SCREW NR.82X 2,5	3L2	K993 03 765 7	SENKSCHRAUBE SCREW M4X8	1D8
K990 12 012 2	KEILRIEMEN V BELT 10 X 1500	5F12 6G12	K992 00 104 0	ZYL STIFT CYLIND PIN 2,70X10,7	1G6	K992 01 510 0	SENKSCHRAUBE SCREW NR.13	3K2	K993 06 092 7	SCHRAUBE SCREW M3X4	2L9
K990 12 012 3	KEILRIEMEN V BELT 10 X 1550	5F12 6G12	K992 00 216 0	GEWINDESTIFT THREADED PIN NR.28X 9,5	1F4	K992 01 511 0	GEWINDESTIFT THREADED PIN NR.18X 6,5	2G5 2H8			
K990 20 164 0	STOPFEN	1B3 3M12									
K990 23 040 9	PERILEXSTECKER 16A 5POL	5A6 5D6									
K990 24 005 7	MUFFE	7K12									

Teile-Nr.	Benennung	Bildtafel	Teile-Nr.	Benennung	Bildtafel	Teile-Nr.	Benennung	Bildtafel	Teile-Nr.	Benennung	Bildtafel
K993 06 097 7	SCHRAUBE SCREW M3X12	2M9	K993 19 037 7	SCHEIBE DISC B5,3	3D8 4C6 4G6 4J11 4K8 6B1	K993 91 063 8	SCHRAUBE SCREW M3X10	1J1 2K3	K993 91 124 8	SCHRAUBE SCREW M6X16	3H4
K993 06 132 7	SCHRAUBE SCREW M4X4	6G7	K993 19 038 7	SCHEIBE DISC B6,4	2F5 3H7 3K7 6D7 6J2	K993 91 070 8	SCHRAUBE SCREW M3X6	2J3	K993 91 126 8	ZYL.SCHR. M6X20	1H4 4E9
K993 06 133 7	SCHRAUBE SCREW M4X5	1K6	K993 19 040 7	SCHEIBE DISC B8,4	6D9	K993 91 081 8	ZYL.SCHR. M4X8	2M4 2D7	K993 91 127 8	ZYL.SCHR. M6X22	3D12
K993 06 134 7	SCHRAUBE SCREW M4X6	4A4 4B4	K993 19 046 7	SCHEIBE B19	7L11	K993 91 082 8	ZYL.SCHR. SCREW M4X10	2J1 4A2	K993 91 129 7	ZYL.SCHR. M6X30	2M2
K993 06 135 0	ZYL.SCHR. M4X8		K993 19 064 7	SCHEIBE	7L12	K993 91 083 7	ZYL.SCHR. M4X12	2F4	K993 91 129 8	ZYL.SCHR. M6X55	2M5 4E9
K993 06 135 7	SCHRAUBE SCREW M4X8	6B1 6C4	K993 19 137 7	SCHEIBE	6C4	K993 91 083 8	SCHRAUBE SCREW M4X12	1H8 1M8	K993 91 134 7	ZYL.SCHR. M6X16	6J3
K993 06 136 7	SCHRAUBE SCREW M4X10	4E4 4E5	K993 26 096 8	FLUEGELSCHRAUBE FLY SCREW M4X15	1C4	K993 91 084 7	SCHRAUBE SCREW M4X16	2F8 3D10 3M5	K993 91 144 7	SCHRAUBE SCREW M8X16	1K11
K993 06 137 7	SCHRAUBE SCREW M4X12	6G1	K993 34 054 7	MUTTER	3D11 3L5	K993 91 084 8	ZYL.SCHR. M4X16	3B9	K993 91 146 7	SCHRAUBE SCREW M8X20	4H9
K993 06 144 7	SCHRAUBE SCREW M4X30	4D7	K993 34 056 7	MUTTER NUT M4	2G6	K993 91 085 7	SCHRAUBE SCREW M4X18	4K6	K993 91 152 7	SCHRAUBE SCREW M8X45	6D6
K993 06 155 7	ZYL.SCHR.	2J5	K993 34 057 7	MUTTER NUT M5	1J8 2L5 3D9 4L9	K993 91 085 8	ZYL.SCHR. M4X18	2H9	K993 91 178 8	ZYL.SCHR. M10X25	
K993 06 156 7	SCHRAUBE SCREW M5X10	5M8 6L8	K993 34 058 0	6KT.MUTTER M6		K993 91 086 7	SCHRAUBE SCREW M4X20	3B8	K993 91 180 7	SCHRAUBE SCREW M10X35	3L12
K993 06 256 0	SCHRAUBE SCREW M3X15	4C3	K993 34 058 7	MUTTER NUT M6	4J9	K993 91 103 7	ZYL.SCHR.	1J1 1L1	K993 91 185 7	SCHRAUBE SCREW M10X60	2E8
K993 06 283 0	SCHRAUBE SCREW M5X8	1B3 1K6	K993 39 128 7	RAENDELSCHRAUBE KNURLED SCREW M6X15	4D4	K993 91 103 8	ZYL.SCHR. M5X12	1E6 4C6 4D4	K993 91 189 7	SCHRAUBE SCREW M10X80	3L12
K993 07 355 7	SCHRAUBE SCREW M4X8	3K4	K993 39 321 7	RAENDELSCHRAUBE KNURLED SCREW M4X15	6D5 6D8	K993 91 104 8	ZYL.SCHR. M5X16	2G9	K993 92 069 8	GEWINDESTIFT THREADED PIN M3X3	1L6 7D7
K993 07 375 7	SCHRAUBE SCREW M5X8	1E7 1E10 3K4	K993 41 120 8	RAENDELMUTTER KNURLED NUT POLY M5	1D7 1L8	K993 91 105 8	ZYL.SCHR. M5X18	4H7	K993 92 070 8	GEWINDESTIFT THREADED PIN M3X4	1F5
K993 07 377 7	SCHRAUBE SCREW M5X12	7D11	K993 52 093 0	GEWINDESTIFT THREADED PIN M4X4	1D7	K993 91 106 8	ZYL.SCHR. M5X20	1E5	K993 92 074 8	GEW.STIFT C3X10	3H9
K993 16 176 7	SENKSCHRAUBE SCREW 5X25	7D9	K993 52 096 0	GEW.STIFT M4X8	2G7	K993 91 108 7	SCHRAUBE SCREW M5X25	4L10	K993 92 076 8	GEWINDESTIFT THREADED PIN M4X4	1D5 1L7
K993 19 034 7	SCHEIBE DISC 3,2	1F1	K993 52 105 0	GEWINDESTIFT THREADED PIN M5X6	1J6	K993 91 108 8	SCHRAUBE SCREW M5X25	4E8	K993 92 098 8	GEWINDESTIFT THREADED PIN M5X5	1C5
K993 19 036 7	SCHEIBE DISC 4,3	4B4 5M8	K993 90 400 8	SCHRAUBENDREHER SCREWDRIVER F.I.6KT.SW 1,5 X40	3F7 7J6	K993 91 110 7	SCHRAUBE SCREW M5X35	4J9	K993 92 099 8	GEW.STIFT M5X6	2G1
			K993 91 061 8	SCHRAUBE SCREW M3X6	2E2	K993 91 122 8	ZYL.SCHR. M6X10	2F6	K993 92 100 8	GEWINDESTIFT THREADED PIN M5X8	1E6 6D7
						K993 91 123 7	SCHRAUBE SCREW M6X12	2F6 2F8 3H7 6K4	K993 92 120 8	GEWINDESTIFT THREADED PIN M8X8	2J10
						K993 91 123 8	SCHRAUBE SCREW M6X12	6J2			

Teile-Nr.	Benennung	Bildtafel	Teile-Nr.	Benennung	Bildtafel	Teile-Nr.	Benennung	Bildtafel	Teile-Nr.	Benennung	Bildtafel
K993 94 075 8	GEWINDESTIFT THREADED PIN M 3 X 6	3F5	K994 05 036 7	MUTTER NUT M4	1G8 2J5 4D7 5L8 6F1	K994 46 534 7	SCHRAUBE SCREW M5X12	2A6 2A9	K996 23 023 0	KUGELLAGER BALLBEARING 1203 TV (17X40X12)	1H9
K993 94 102 8	GEWINDESTIFT THREADED PIN M5X12	1L1	K994 05 037 7	MUTTER NUT M5	4E8 4G6 4G8 4J11 4K11 4L8	K994 52 002 0	SCHRAUBE SCREW M 4 X 8A	5E7 6C5	K996 23 068 0	KUGELLAGER BALLBEARING 15X 42X13	1H6
K993 94 121 8	GEWINDESTIFT THREADED PIN M8X10	1H8	K994 05 038 0	6KT.MUTTER M6	4E9	K994 80 146 7	SCHEIBE DISC B6,4	2M2 4L9	K996 28 080 0	DICHTRING GASKET RING A 13X19X2	5H12 5L11 5M11 6K1 6K2 6K10 6M12
K993 95 070 8	GEW.STIFT M3X4	3F2 3F4	K994 05 038 7	MUTTER NUT M6	3K7 6D7 6K1 7C11	K995 14 021 7	RAENDELMUTTER KNURLED NUT M6	4D4	K996 35 029 0	DICHTRING GASKET RING C 12X16	2E8
K993 95 081 8	GEWINDESTIFT THREADED PIN M4X5	4D7	K994 05 040 7	MUTTER NUT M8	3H4	K995 34 061 7	MUTTER NUT PG11X9	7L11 7L12	K996 38 058 0	DICHTRING GASKET RING A15X24X7	2F4
K993 95 092 8	GEW.STIFT M5X6	1F8	K994 10 093 0	STIFTSCHRAUBE SCREW M4X20	2H6	K996 01 088 8	SICHERGS RING CIRCLIP 12X1	4E5	K996 49 018 0	RIEMENSCHLEIBE PULLEY A 100-L	5E12 6F12
K993 95 094 8	GEW.STIFT M5X10	2L9	K994 25 071 7	SCHEIBE DISC 4	3D7	K996 01 091 8	SICHERGS RING CIRCLIP 15X1	1G7 3C10	K996 49 021 0	RIEMENSCHLEIBE PULLEY A 118-L	5E12 6F12
K993 96 158 7	SCHRAUBE SCREW M5X6	1H7	K994 27 171 0	KERBSTIFT 8X32	1M8 2C9	K996 01 092 8	SICHERGS RING CIRCLIP 16X1	3A9	K996 61 120 0	KUGELZAPFEN BALL PIVOT A 8	4E8 4G8 4K11
K993 96 160 7	SCHRAUBE SCREW M5X10	1K5	K994 29 077 0	PASSKERBSTIFT GROOVED PIN 3X20	1J3	K996 02 127 8	SICHERGS RING CIRCLIP 47X1,75	1H7 1H9	K996 61 145 0	KUGELPFANNE BALL SOCKET B 8	4E8 4G8 4K11
K993 97 098 7	SCHRAUBE SCREW M4X8	3C6 3G5	K994 33 043 6	KERBNAGEL SLOT NAIL 2X6	3G10 3J9	K996 06 017 0	KUGEL BALL 3,969	1H5	K997 15 350 0	STECKHUELSE RECEPTACLE 6,3-1	5H0 5L8 6F7 6H2 6K8
K993 99 104 7	FLACHKOPFSCHR. M3X1,6	3L9	K994 33 054 7	KERBNAGEL SLOT NAIL 2,3X7	3K5	K996 06 025 0	KUGEL BALL 6,350	1F6	K997 50 260 0	FEINSICHERUNG FUSE T 800	7K6
K993 99 191 0	SCHRAUBE SCREW M6X8	1C5	K994 33 075 0	KERBNAGEL SLOT NAIL 3X8	4K6	K996 07 006 8	SICHERGSSCHLEIBE SAFETY DISC 3,2	1E6 1E7 1F8 1K3 2M2 3D8	K997 70 090 1	LEITUNG CABLE 1 X 0,5 BR	6E2
K994 04 106 7	SCHRAUBE SCREW M3X8	1H4	K994 38 022 8	SPANNHUELSE CLAMPING SLEEVE 1,5X6	1G3	K996 07 008 8	SICHERGSSCHLEIBE SAFETY DISC 5	4J9	K997 70 090 5	LEITUNG, H05V-K 1 X 0,5 BL	6F1
K994 04 109 8	6KT.SCHR. M3X12	1E1	K994 38 034 8	SPANNHUELSE CLAMPING SLEEVE 2X10	4F7	K996 07 010 8	SICHERGSSCHLEIBE SAFETY DISC 7	1L11	K998 68 029 8	SPANNRING CLAMPING RING 5	4K9
K994 04 148 8	6KT.SCHR. M4X10	1L4	K994 38 062 8	SPANNHUELSE CLAMPING SLEEVE 3X6	4K6	K996 08 348 4	RI-KUGELLAGER BALL BEARING 8X19X6	3F7	K998 85 115 0	SIMMERRING SEALING RING BA 9X18X6	2H2 2H9
K994 04 157 7	SCHRAUBE SCREW M4X35	2G5 4D7	K994 38 064 8	SPANNHUELSE CLAMPING SLEEVE 3X10	1D11	K996 08 534 0	RI KUGELLAGER BALL BEARING 6004.2ZR	1G7	K998 86 007 0	RING RING OR 3 X 1	1F6
K994 04 210 8	6KT.SCHR. M6X16	6C7	K994 38 085 8	SPANNHUELSE CLAMPING SLEEVE 4X12	4H7	K996 19 017 0	DRAHTNAGEL A 14X25	7E9	K998 86 027 0	O-RING RING 7X1,5	1L1
K994 04 218 8	6KT.SCHR. M6X40	6C6	K994 38 107 8	SPANNHUELSE CLAMPING SLEEVE 5X16	4J6	K996 19 307 0	DRAHTNAGEL, FB 20X20	5G8	K998 86 028 0	O-RING RING 12X1,5	3H8
K994 04 284 7	SCHRAUBE SCREW M8X25	6E9	K994 46 100 7	SCHRAUBE SCREW M5X10	3G6	K996 19 333 8	KAMMZWECKE, FB 16 X 16		K998 86 072 0	O-RING RING	1D4 1C4 1K1 2F5
K994 05 034 7	MUTTER NUT M3	1F1 1J3 1K3	K994 46 101 7	SCHRAUBE SCREW M5X12	1H11						

Teile-Nr.	Benennung	Bildtafel	Teile-Nr.	Benennung	Bildtafel	Teile-Nr.	Benennung	Bildtafel	Teile-Nr.	Benennung	Bildtafel
K998 86 346 0	O-RING RING 40X2	1G6	K999 20 100 4	STECKER PLUG MES 160	5K9	K999 20 140 3	KUPPLUNG COUPLER MEK 160	6D2	K999 20 215 9	CODIERUNG GELB CODE YELLOW GELB	6E7-6J10
K998 86 500 0	O-RING RING 3,3X2,4	1H4	K999 20 101 8	KABELKANAL CABLE CHANNEL 33X30/BA6	5M8-6L8	K999 20 146 3	POTENTIOMETER POTENTIOMETER 2 K OHM	4F8	K999 20 216 0	GABELKONTAKT FORK CONTACT	6E7
K998 87 017 8	RING RING A 20 X1,2	2J8	K999 20 105 9	SCHUTZSCH.EINSATZ 4,0-63A	5C5 5F5	K999 20 148 0	SCHUTZSCH.-EINSATZ 1,6-2,5 A	5C5 5F5	K999 20 216 3	STECKER PLUG 16 POLIG	6E7-6H10
K998 88 110 0	PASS SCHEIBE WASHER 10X16X0,3	2F7	K999 20 111 3	HUELSE BUSH B6 GLASKLAR	5H9-5K8 6H2 6K8	K999 20 149 4	SHELLE CLAMP 1-481	4D3 4E4	K999 20 222 5	NETZTEIL MAINS UNIT 220/5/3	6G5
K998 88 111 0	PASS SCHEIBE WASHER 12X18X0,3	4F5	K999 20 111 4	FLACHSTECKER TAB GSZ 0	5F8 6C6	K999 20 153 3	KABELSCHUH TERMINAL PVC-ISOLAT	5A4 5D4	K999 20 223 1	KAPPE CAP	6G7
K998 88 152 0	PASS SCHEIBE WASHER 8X14X0,5	1C5	K999 20 115 4	BEF SHELLE CLAMP 604-5	1J6 4B4	K999 20 153 7	LEUCHTDIODE LUMIN DIODE ROT LD30A	4A1 4D1	K999 20 223 4	STECKERGEHAEUSE PLUG CASE	6H10
K998 91 014 0	SPRENGRING SPRING RING SB11	1D10 1H7	K999 20 116 0	SCHUKOSTECKER PLUG PEHA6172	6D3	K999 20 157 0	INTEGRSCHALTUNG INTEGR CIRCUIT L 7812 CV	4C3	K999 20 223 5	BUCHSENGEHAEUSE BUSHING	6H10
K999 18 170 7	LEITUNG,H07V-K 1,5 SW	5G8	K999 20 116 2	SCHUCOSTECKDOSE SOCKET 2030WJPS	6B9 6J6	K999 20 157 1	KABELKANAL CABLE CHANNEL HVK1	4B4	K999 20 223 6	BUCHSE	6H10
K999 18 790 0	LEITUNG,H03VV-F 2 X0,5 SW	6H1	K999 20 125 7	STEUERLEITUNG CONTROL LEAD 10 X 0,34	5L8	K999 20 160 0	STECKHUELSE RECEPTACLE A2,8X1	4A2	K999 20 223 7	STIFT PIN	6H10
K999 18 905 4	LEITUNG CABLE 3 G1,0 GR	6L6	K999 20 128 6	STECKER PLUG 71430-030	4F4	K999 20 160 3	ISOLIERPLATTE INSUL PLATE 105 338	4B3	K999 20 250 0	STECKHUELSE 5 MM ISOLIERT	5F8
K999 18 905 7	LEITUNG CABLE 3 X1,0 SW	5B4 6B9	K999 20 130 3	SCHUTZSCH.-EINSATZ 2,5-4,0 A	5C5 5F5	K999 20 161 8	HUELSE BUSH B-3	4A2	K999 20 250 1	KABELSCHUH	5G8
K999 18 909 7	LEITUNG CABLE 4 X1,0 GR	5B4 5E4	K999 20 130 4	GEHAEUSE HOUSING GHM6101169	5B6 5E6	K999 20 163 4	STEUERLEITUNG CONTROL LEAD 4 X 0,35	4E4 4G4 5H9 5K10 6H1	K999 21 017 8	GLEITLAGER SLIDE BEAR 16X22X18	3B9
K999 18 913 7	LEITUNG CABLE 5 G1,0 GR	5A5 5D5	K999 20 131 1	STECKERGEHAEUSE PLUG CASE 4 POLIG	2J6 6D2 6G3	K999 20 169 1	STEUERLEITUNG CONTROL LEAD 7 X 0,34	4C4	K999 21 027 1	SCHNEIDRING	6K2
K999 20 043 6	SHELLE CLAMP ISO 4 - 7	5F7	K999 20 131 2	GEHAEUSE HOUSING 4 POLIG	5H12 5K12 6H2 6H9 6K6	K999 20 171 3	LEUCHTDIODE LUMIN DIODE KL.GRUEN L37II	4B1	K999 21 044 1	GELENKKOPF JOINT HEAD GI 6	4J9
K999 20 044 0	WUERGENIPPEL TWIST NIPPLE PG16	5B6 5E6 6B9	K999 20 131 3	BUCHSE BUSHING 163304-2MNL MS VER	5H12 5K12 6H2 6H9 6K6	K999 20 171 4	LEUCHTDIODE LUMIN DIODE LY3160-J	4D1	K999 21 056 9	GELENKLAGER BEARING LN 9193	3E7
K999 20 089 0	KABELBAND CABLE TAPE 203MM LANG	5H10-5K8 5K11 6K8	K999 20 131 4	STIFT PIN 163305-2MNL MS VER	2J6 6D2 6G3	K999 20 175 1	KABELBAND CABLE TAPE SST1,5M-M	4F5	K999 21 093 6	GLEITLAGER SLIDE BEAR 5X 9X 8	1J4
K999 20 089 5	STECKER PLUG MES 100	5H11 6G1-6K10	K999 20 136 8	ROHR PIPE PG 16	5B4 5E4	K999 20 175 3	GEHAEUSE HOUSING 09-91-1200	6B3	K999 22 047 5	SCHLAUCH-KLEM. HOSE SOCKET A 4X0,3X10	1B10
K999 20 093 6	BEF SHELLE CLAMP VERNICK. 605-13	2J5 6F1	K999 20 136 9	STECKDOSE SOCKET 71206-030	4F4	K999 20 196 1	TASTE SWITCHING KEY " 0 "	6H4	K999 22 047 6	EINSTECHHUELSE A 4X0,3X10	6L2
			K999 20 140 2	SCHLAUCH HOSE FP301-2-48	2J6 6F1	K999 20 205 1	GEDR.SCHALTUNG KAW164	4C1	K999 22 063 5	SCHLAUCHTUELLE HOSE SOCKET R 1/4-D 6	5J11 5M11 6K1 6M12

Teile-Nr.	Benennung	Bildtafel	Teile-Nr.	Benennung	Bildtafel	Teile-Nr.	Benennung	Bildtafel	Teile-Nr.	Benennung	Bildtafel
K999 22 075 7	ZYLINDER CYLINDER D16X25	4K9	K999 24 038 3	VERSCHRAUBUNG COUPLING R 1/8"D 4	5K9 5M9 6L8	MG43 00 056 8	LAUFROLLE	5J4	0791 00 109 4	LINSENK.ZYL.SCHR.	7J9 7K9
K999 22 076 5	VENTIL VALVE MAGNET-3/2 M 5	2K2	K999 24 038 5	WI-E-VERSCHR.	6L8	MG43 00 250 2	FUSSTRITTPLATTE TERLURAN RAL9005	5K4	0791 00 109 5	MUTTER	7H9 7K10
K999 22 081 0	KOLBENDICHTUNG 10X6X2,55	1C5	K999 24 038 7	VERSCHRAUBUNG COUPLING R 1/8" D4	5L8	MG43 00 250 5	BUEGEL	5M5	0791 00 109 6	FADENFUEHRG KPL THREADGUIDE CPL	7J10
K999 22 084 0	KOLBENDICHTUNG 18 X 12 X 2,55	1L3	K999 24 038 9	SCHLAUCHTUELLE HOSE SOCKET M 5 D 2	2F9	MG43 00 250 7	GREIFRING G 12X1,2	5M6	0798 10 084 2	STECKHUELSE 05505 123 211	6E2
K999 23 015 8	DICHTRING GASKET RING G7X11X2	2L8	K999 24 039 0	VERSCHRAUBUNG COUPLING M 5 D 4	2F9	MG43 00 250 8	BEF.WINKEL	5K4	0798 10 102 4	ISOLIERTUELLE 16190 502 501	6F1
K999 23 050 2	NADELLAGER NEEDLE BEARING RNAO 5X10X8 TN	1L11 3C10 3D11 3K6 3L6	K999 24 039 1	VERSCHRAUBUNG COUPLING M 5 D 4	1L1 2K2 2L1 4F11 4J9	MG43 00 250 9	BLECH.SCHR. B 6,3X19,0	5K4 5M4	0798 22 014 2	KABELVERSCHR. SYNEC PC11	5A5
K999 23 056 3	NADELHUELSE NEEDLE SOCKET HK 0912	3H7	K999 24 039 2	VERSCHRAUBUNG COUPLING R 1/8"D 6	5H8 5H12 5J12 5L11 5M11 6K12 6M12	MG43 00 251 0	SCHEIBE	5K4 5L4			
K999 23 804 1	NADELHUELSE NEEDLE SOCKET HK 0808 A	4L11	K999 24 039 4	VERSCHRAUBUNG COUPLING D4	6J12	MG43 00 252 2	FUSSTRITTPLATTE TERLURAN RAL 9005	5K3			
K999 24 003 9	VERSCHRAUBUNG COUPLING R 1/4"	5H12 5L11 6K1 6K12	K999 24 039 6	MUFFE BUSHING M 5	2F9	MG43 00 255 1	PEDAL KPL 2-PEDAL	5K3			
K999 24 025 5	WI-E-VERSCHR.	6K2	K999 24 041 3	L-VERSCHRAUBG. LCN-M3-PK-2	1C3	MG43 00 255 2	WELLE VOL.	5L3			
K999 24 026 9	BLINDSTOPFEN BLIND PLUC G 1/8"	5J11 5M10 6J3 6M10	K999 28 080 0	DICHTRING	5J10 5M10	MG43 00 255 6	ANSCHLAGWINKEL	5M4			
K999 24 030 1	DOPPELNIPPEL	5J10 5M10	K999 31 072 0	KERBSTIFT S7 3X10	2F5	MG43 00 255 8	HEBEL	5L5			
K999 24 030 2	DOPPELNIPPEL DOUBLENIPPLE R1/8-R1/8"	5J9 5K9 5M9 6J3 6K9 6M8	K999 31 097 7	KERBSTIFT S67 4X20	2C10	MG43 00 451 0	ZUGSTANGE	5G6			
K999 24 030 3	DOPPELNIPPEL DOUBLENIPPLE R1/4-R1/8"	5H10 5K11 6K10	MG41 00 117 1	FORMFEDER	5L3	0720 00 004 2	6KT.MUTTER M 8,0 5.8.VZI	5K5 5K7 5M3 5M4 5M6 6K7			
K999 24 030 4	REDUZIERNIPPEL REDUCING NIPPLE R1/4-R1/8"	5H11 5J12 5K11 5M11 6K2 6K10 6M12				0271 00 144 2	LINSENSCHR. M 4X7	5B4 5E5			
K999 24 030 6	MUFFE BUSHING R 1/4"	3J11 5M11 6K1 6L12				0720 00 004 3	SCHEIBE 8,4	5G2 5K5 5M3 5M4 5M6			
K999 24 034 1	VERSCHRAUBUNG COUPLING R 1/8"D17	5J9 5M9 6M8				0720 00 012 7	6KT.SCHRAUBE M 8X25 8.8 VZI	5M6			
K999 24 035 3	WINKEL E-VERSCHR.	6K3				0720 00 029 3	6KT.SCHRAUBE M 8X35 8.8 VZI	5K5			
K999 24 036 5	SCHWENKVERSCHR PIVOT COUPLING M 5	1L1				0725 00 052	OBFEDERRING A 8	5H8 5K7 6K7			
						0744 00 220 8	BEF.SCHELLE H3P	5C4			
						0791 00 108 1	GARNST ROHR YARN SUPP TUBE LANG	7K10			
						0791 00 108 4	GARNST ROHR KPL YARN SUPP TUBE	7M11			
						0791 00 108 5	GARNST.ROHR KURZ UNTEN	7K12			
						0791 00 108 6	GARNST.ROHR KURZ OBEN	7J12			
						0791 00 108 8	GARNST.ROHR GETEILT	7M12			
						0791 00 109 0	GARNHALTER KPL YARNHOLDER CPL	7K10			
						0791 00 109 1	GARNHALTER KPL YARNHOLDER CPL	7K9			
						0791 00 109 3	SASCHEIBE	7J9 7K9			

Teile-Nrn. neu hinzu 09.1999

NB311	000012	Distanzhülse	7F4	0799	202221	Taster rot	6.111	9201	112497	6kt.Schr.	3K6
MG53	501	Gestell K	5H3	0802	511690	Buchse	1C1	9201	112898	6Kt.Schrauben	4L8
MG53	2501	Pedal K	5I3	0893	960988	Flachkopfschr.	3H4	9201	113697	6kt.Schr.	6K7
MG50	005041	Blech	7E4	0893	960988	Flachkopfschr.	7G7	9202	002088	Zyl.Schr.	3F6
0002	008971	8060 Druckl. Schlauch	2A7	0902	000097	Senkschraube	7E4	9202	002098	Zyl.Schr.	3D5
0030	001340	Feder	1C2	0907	021114	Teilesatz K (Schubkasten)	5E3	9202	022878	Zyl.Schr.	3B6
0098	002990	Druckfeder	1D3	0980	424370	Buchse	2A8	9202	042498	Zyl.Schr.	2A8
0104	250010	Haube G5	7A9	0990	254291	Positionsgeber	5B8	9203	003647	Zyl.Schr.	5M8
0114	000202	Stegscheibe	1D6	0990	254292	Netzteil	5G9	9203	003948	Zyl.Schr.	1H9
0196	001930	Buchse	2H4	0990	254319	Steuerplatte	5F11	9203	112454	Flachkopfschr.	7G7, 3F2, 3F6
0296	150013	Lager V	1K11	0990	254432	Nähانtrieb	5D11	9203	312451	Senkschr.	3E3, 7C6
0367	130153	Stellring	1H9	0992	024358	Zyl.Schr.	3H5	9205	101588	Gew.Stift	3F6
0396	121000	Lenkerbolzen	1F3	0993	030947	Senkschr.	1C2	9231	000347	6kt.Mutter	3C5, 3H6, 3K7
0396	121170	Nadelst. Buchse	1L6	0993	031357	Senkschr. M4x8	7J4, 7L2	9231	110057	6kt. Mutter	5L8
0396	150770	Mutter	3F10	0993	037527	Senkschr. M3x8	7H3	9231	110137	6Kt.Mutter	6K7
0396	160310	Zugfeder	2F6	0993	190367	Scheibe 4,3	7G3, 7H1, 7J1, 7L4	9330	000087	Scheibe	5M8
0396	341110	Stellklöben	1E2	0993	190387	Scheibe 6,4	7H2	9330	000097	Scheibe	3C3
0396	342580	Drehfeder	1E1	0993	190417	Scheibe 10,5	7J2	9352	000150	Sich.Ring	3B5
0396	343060	Bundbüchse	1D1	0993	260968	Flügelschr.	1C1	9710	981010	Schalldaempfer	6K10
0396	343073	Stellscheibe V	1E1	0993	340567	6kt.Mutter M4	7H3, 7L4	9731	006004	Schlauch	6K12
0396	343120	Exz.Bolzen	1E3	0993	340577	6 Kt.Mutter	2L2	9781	000002	Filterregler	5M10, 5J10, 6M10
0396	343150	Bolzen	1D3	0993	910808	Zyl.-Schr. M4x6	7G3, 7H1	9790	200001	Verschr.-GD-E	6L8, 5M9
0550	481354	Halterung	7L1	0993	910828	Zyl.-Schr. M4x10	7J1	9790	315002	Schlauchtuelle	3G11
0550	481360	Träger	7L3	0993	911028	Zyl.Schr.	4K8	9792	051020	Muffe	6L12
0550	481370	Schlitten	7H4	0993	911038	Zyl.Schraube	1E2	9792	102010	Wi-Stueck	6K12
0550	481380	Führung	7H4, 7J4	0993	911048	Zyl..Schr.	1E2	9792	301010	Dichtring	6M12
0550	481403	Platte	7F3	0993	911068	Zyl.Schraube	1E1	9800	120007 A	Nähانtrieb	5.1B7
0550	481410	Lager	7F3	0993	911238	Zyl.-Schr. M6x12	7J3	9800	310002	Kupplungsscheibe	5.1D12
0550	481430	Strebe	7J3	0993	911257	Zyl.-Schr. M6x18	7H2	9800	310003	Bremsscheibe	5.1D8
0550	481504	Bedienpult K	6B8	0993	911257	Zyl.-Schr. M6x18	7H2	9800	310004	Kupplungsmagnet	5.1D12
0550	481534	Plat.Stecker K	6B5	0993	911787	Zyl.Schr.	2E8, 2E10	9800	310005	Bremsmagnet	5.1D8
0550	481544	Plat.Interf.K	6B5	0993	920988	Gew.Stift	1D1	9800	321008	Steuerkasten	5.1L8
0568	140020	Ständer	3L12	0993	921008	Gew.Stift	1D3	9800	327001	Positionsgeber	5.1B5
0568	140200	Kappe	3M9	0993	940758	Gew.Stift	3G5	9800	330001	Ext. Betätigung	5.1F4
0568	140473	Säulenkopf	3H5	0993	950708	Gew.Stift	3H4	9805	791105	RAM-Card	6.1G7
0568	140653	Führ.Stück	3G3, 7B4	0993	991910	Fl.Kopfschr.	1C3	9825	151611	Stecker	5K8
0568	140720	Feder	3G5	0994	050387	6kt.-Mutter M6	7M3	9825	151001	Stecker	5H11, 5K11, 6K10
0568	150140	Mittelt.Halter	3H4	0994	384550	Spannstift	1D1	9825	151601	Stecker, Winkel	6H10
0568	200333	Stichplatte	3G5, 7B2	0994	801467	Scheibe 6,4	7M3	9825	153002	Codierung	6J10
0568	220434	Drueckerfuss V	3E5	0996	060250	Kugel	1D3	9825	180300	Stiftgehaeuse	6H10
0568	310240	Feder	1H4	0996	070068	Sich.Scheibe	1E2, 1E3	9825	180301	Buchsengehaeuse	6H10
0568	340090	Einst.Scheibe	1C3	0996	283840	Dichtring	5L11, 5M11	9840	104201	Flachst.Huelse	5L8, 6L8
0568	340123	Vorschubhülse	3I7, 3I8	0998	861590	O-Ring	1F10	9840	104212	Schutzhuelse	5K8, 6K8
0568	340140	Achse	3I8	0998	880610	Paszscheibe	3F12	9840	106002	Stiftkontakt	6H10
0568	340503	Lagerbock	1D3	0998	881040	Paszscheibe	1E10	9840	106003	Buchsenkontakt	6H10
0568	340530	Buchse	1D3	0998	881520	Pabzscheibe	1C3	9840	111003	Flachstecker	6J10
0568	340540	Zistan	1C2	0998	882100	Paszscheibe	2F8	9840	121001	Kabelbinder	5K8, 5H10, 6K8
0568	340550	Einst.Knopf	1C2	0998	912110	Sprengring	1D5	9840	902000	Kabelkanal	6L8
0568	340570	Zahnriemen	3G4	0999	202390	Schalter	6G10	9850	550009	Leiterplatte	6B4
0568	340954	Lagerbock K	1C1	0999	202679	RAM-Card	6.1F7, 6.1H7	9850	550010	Leiterplatte	6B4
0568	341020	Einstellehre	7K7	0999	202683	Monitor, 7" grau	6.1H7, 6J7	9850	550011	Steuerung K	6.1E7, 6.1G7
0568	341130	Zahnkranz	3G3	0999	202685	Videointerface	6.1H7, 6J7	9850	550031	Bedienpult 200-3	
0742	055716	Senkschr.	3H5	0999	202714	Geh. Rahmen	6B5	9850	550031	Steuerung K	6.1E7
0797	000313	Magnetventil	5M8	0999	202715	Rückwand	6A5	9880	002003	Bedienpult 200-6	
0797	000314	Magnetventil	6L8	0999	210891	Schnappschloss	7H3			Knieschalter	6L12, 6J6
0797	000315	Magnetventil	5M9, 6M9	0999	210936	Gleitlager	3D3, 4K11				
0798	003418	Bedienfeld	5.1B12	0999	220725	Befestigung L	2A8				
0798	100842	Steckhülse	2K3, 2K5	0999	237941	Freilauf	3B6				
0798	101024	Isoliertülle	2K3	0999	240385	WI-E-Verschr. R1/8"D4	5M11				
0798	221022	Durchf. Tuelle	2A7	0999	240401	Schlauchtülle	5M11				
				9120	030084	Rillenkugellager	3F12				

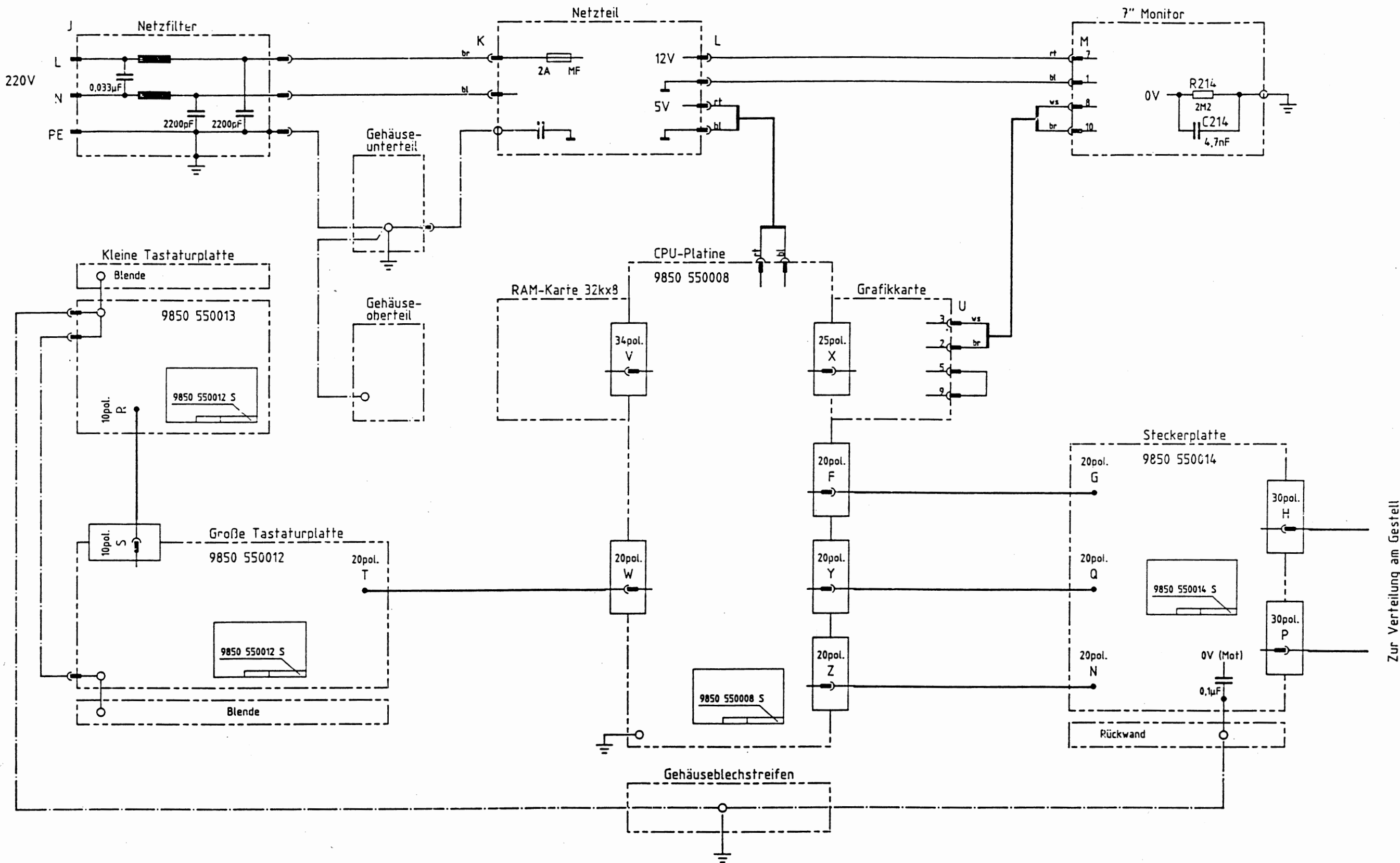

c			Datum	02.03.93
b)			Bearb.	Harder
a			Gepr.	<i>[Signature]</i>
	Anderung	Datum	Name	Norm



DÜRKOPP
ADLER AG
Bielefeld

Teilfamilie	
Freigabe	0117 / 93

Bedienpult 200-3
Struktur

Stromlaufplan k.
9850 550011 SK

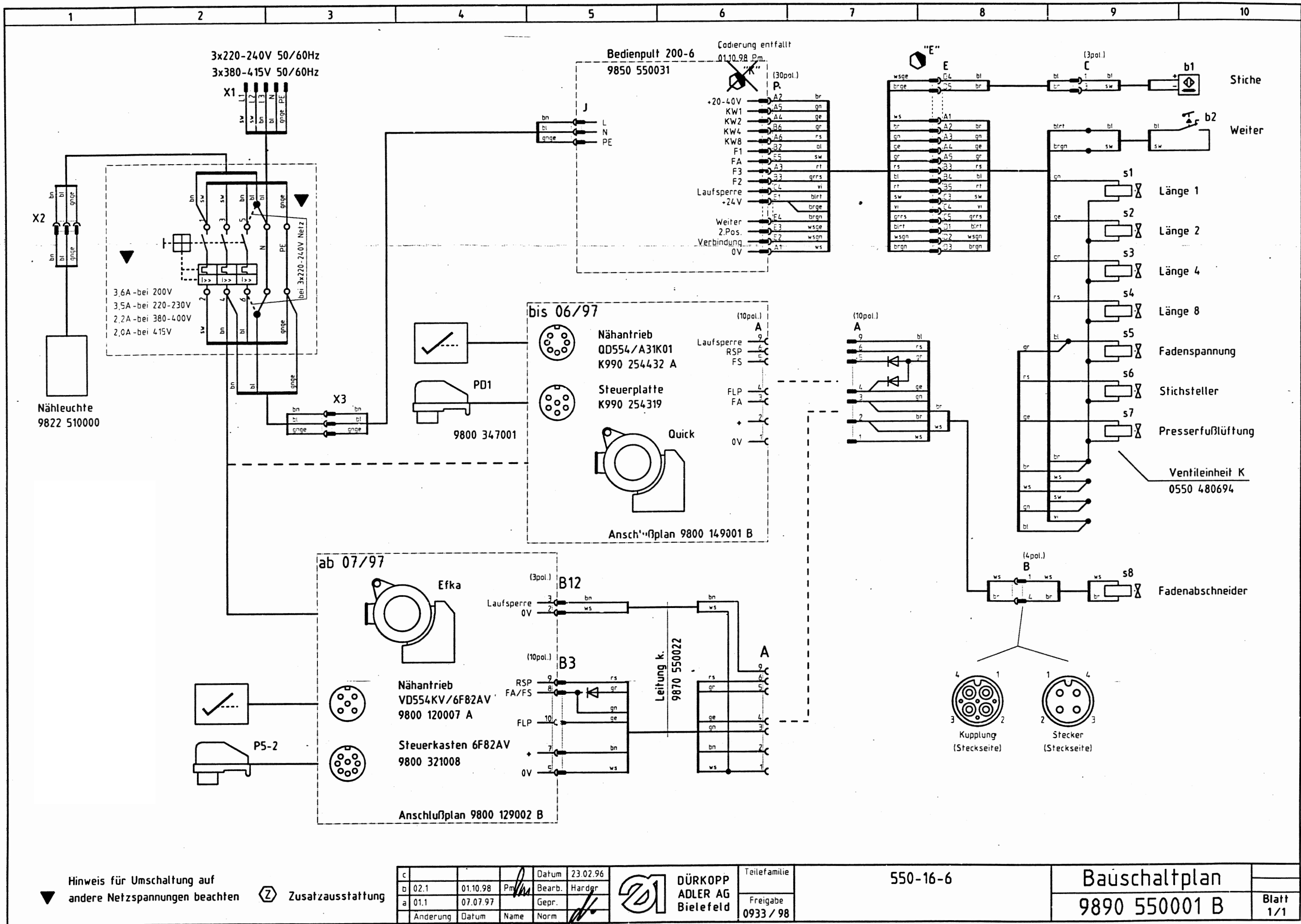

▼ Hinweis für Umschaltung auf andere Netzspannungen beachten

Ⓩ Zusatzausstattung

c			Datum	23.02.96
b	02.1	01.10.98	Bearb.	Harder
a	01.1	07.07.97	Gepr.	
	Anderung	Datum	Name	Norm

DA DÜRKOPP ADLER AG Bielefeld

Teilefamilie 550-16-6

Freigabe 0933 / 98

Oberfrasp. von 2,5-5mm Strichlänge (0=2,5mm, 14=5mm)
 upper feed dog from 2,5-5mm stitch length (0=2,5mm, 14=5mm)
 transport supérieur de 2,5-5mm longueur de point (0=2,5mm, 14=5mm)

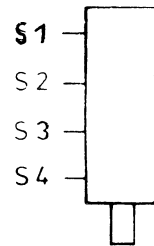

Kräuselwerte ruffling values valeur de plissage	Presserfußlüftung presser foot lifting élévation du pied presseur				
	S1	S2	S3	S4	S8
0	X	X	X	X	
1	—	X	X	X	
2	X	—	X	X	
3	—	—	X	X	
4	X	X	—	X	
5	—	X	—	X	
6	X	—	—	X	
7	—	—	—	X	
8	X	X	X	—	
9	—	X	X	—	
10	X	—	X	—	
11	—	—	X	—	
12	X	X	—	—	
13	—	X	—	—	
14	X	—	—	—	
E	keine Änderung der Ausgänge no output changes sans changement				

X = ein
 on
 fermé

Mehrstellungszylinder
 multi position cylinder
 cylindre de multiposition

Presserfußlüftung
 presser foot lifting
 élévation du pied presseur

FA-Zylinder
 thread cutting device
 coupe fil

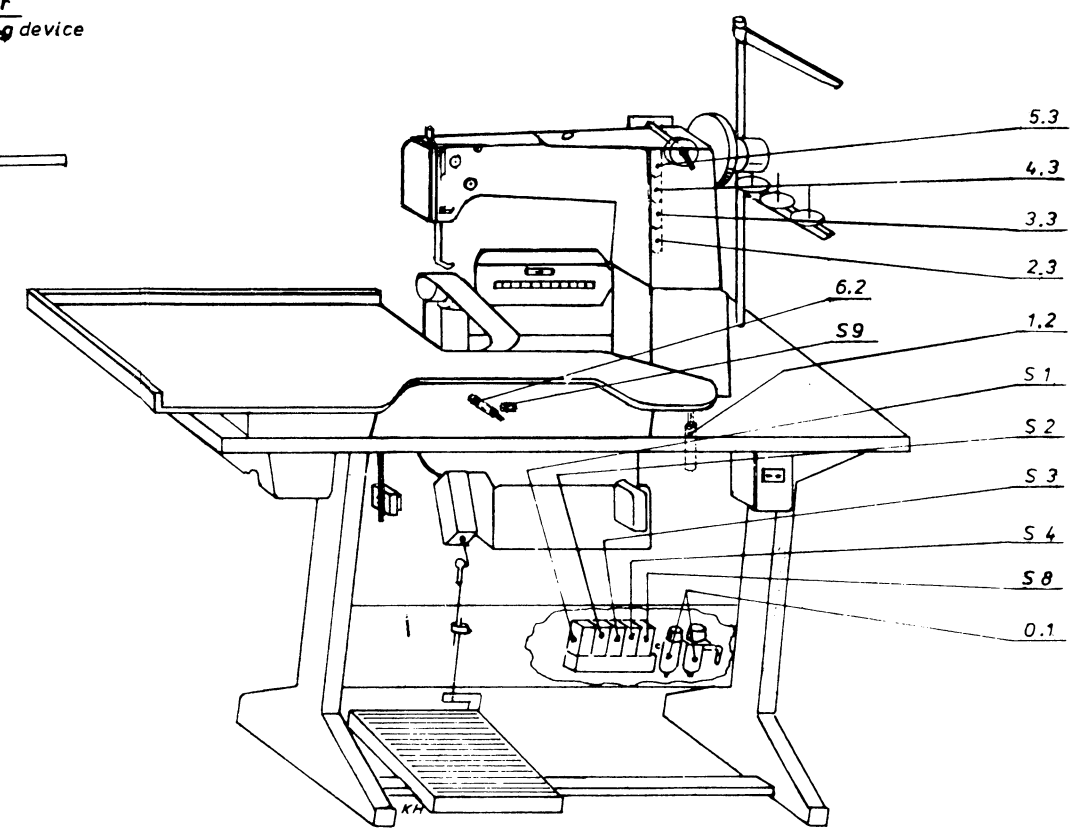
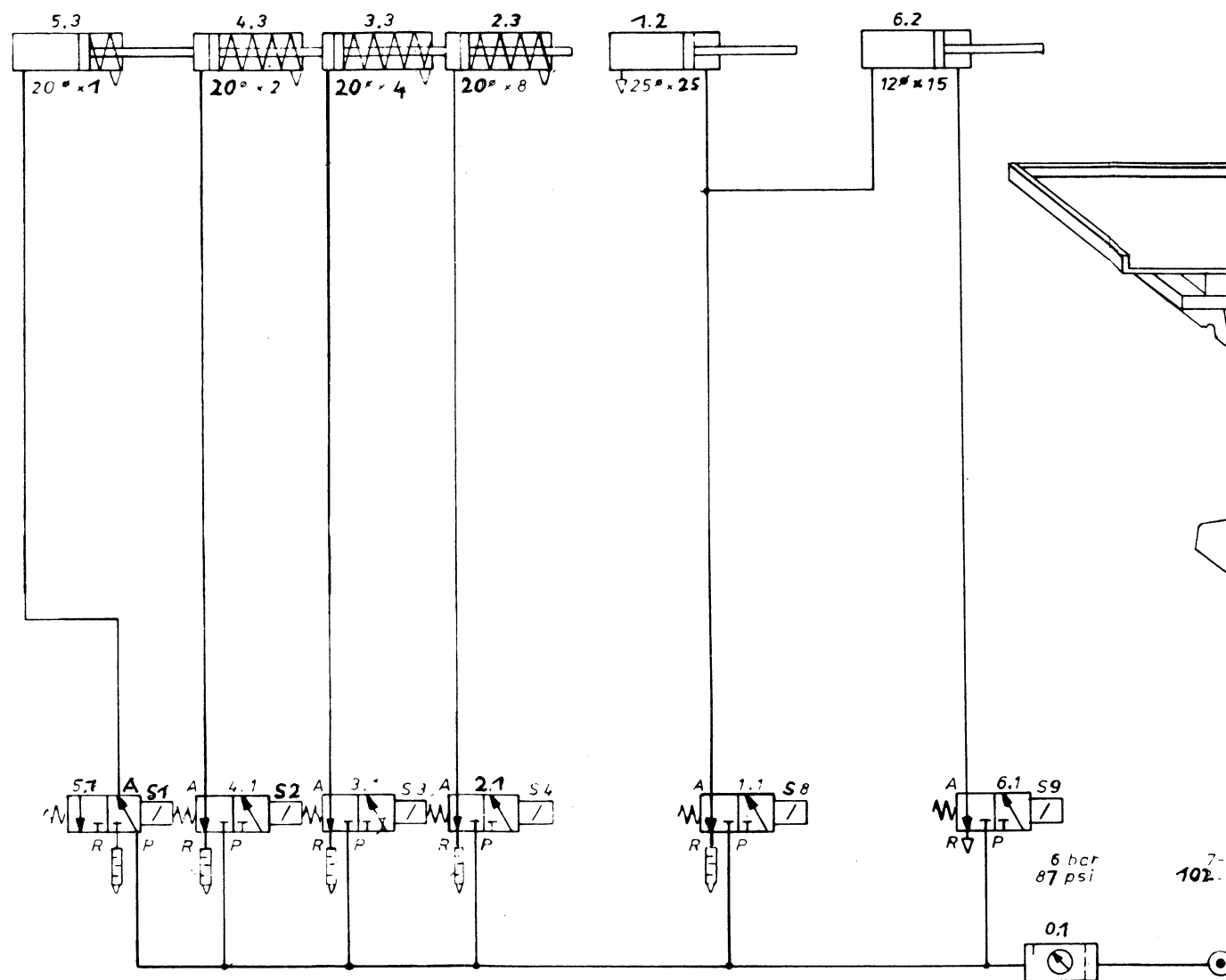

Lageplan
 locating plan
 plan de position

Anmeldung		Bur. statib.	Lage	Datum	Name
Datum	Name	Pneumatik Schaltplan pneumatic circuit plan schema des pneumatiques Kl. 550-16-3		Plan N°	550-P1def-15-02
Ver.	31.5.89				ersetzt durch Ersatz für 550-P1def-15-01
Kochs Adler AG Bielefeld					

Oberfrasp. von 2,5-5mm Stichlänge (0-2,5mm, 14-5mm) /
 upper feed dog from 2,5-5mm stitch length (0-2,5mm, 14-5mm) /
 transport supérieur de 2,5-5mm longueur de point (0-2,5mm, 14-5mm)

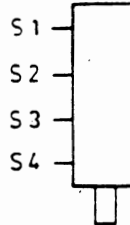

Krüselwerte
 ruffling values
 valeur de pissage

	S1	S2	S3	S4	S5	S6	S7
0	X	X	X	X			
1	—	X	X	X			
2	X	—	X	X			
3	—	—	X	X			
4	X	X	—	X			
5	—	X	—	X			
6	X	—	—	X			
7	—	—	—	X			
8	X	X	X	—			
9	—	X	X	—			
10	X	—	X	—			
11	—	—	X	—			
12	X	X	—	—			
13	—	X	—	—			
14	X	—	—	—			
E	keine Änderung der Ausgänge no output changes sans changement						

X = ein / on / fermé

Fadenspannungslüftung
 thread tension lifting
 relache de la tension de fil
 Stichverdichtung
 stitch compression
 condensation de points
 Presserfußlüftung
 presser foot lifting
 élévation du pied presseur

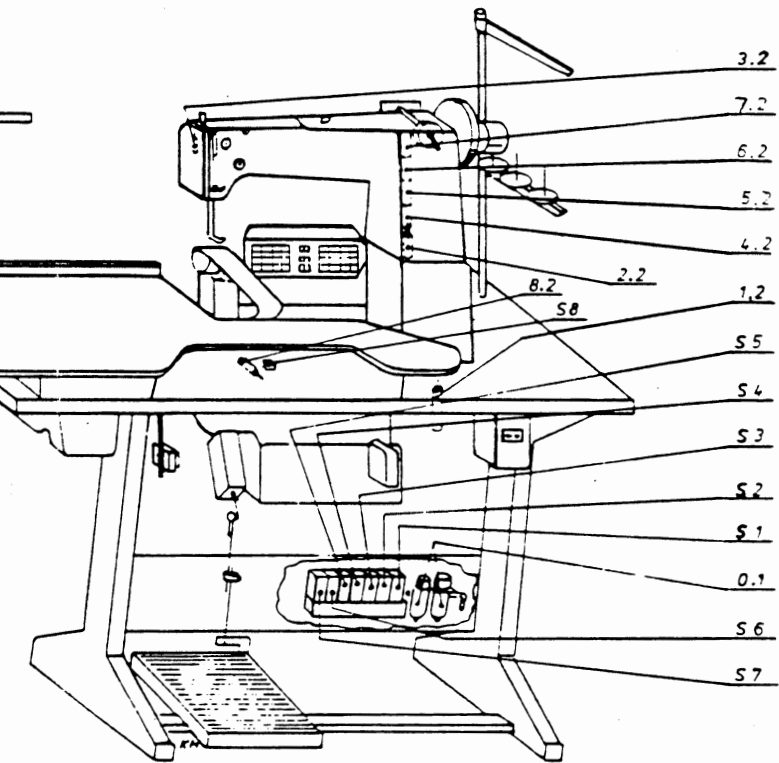
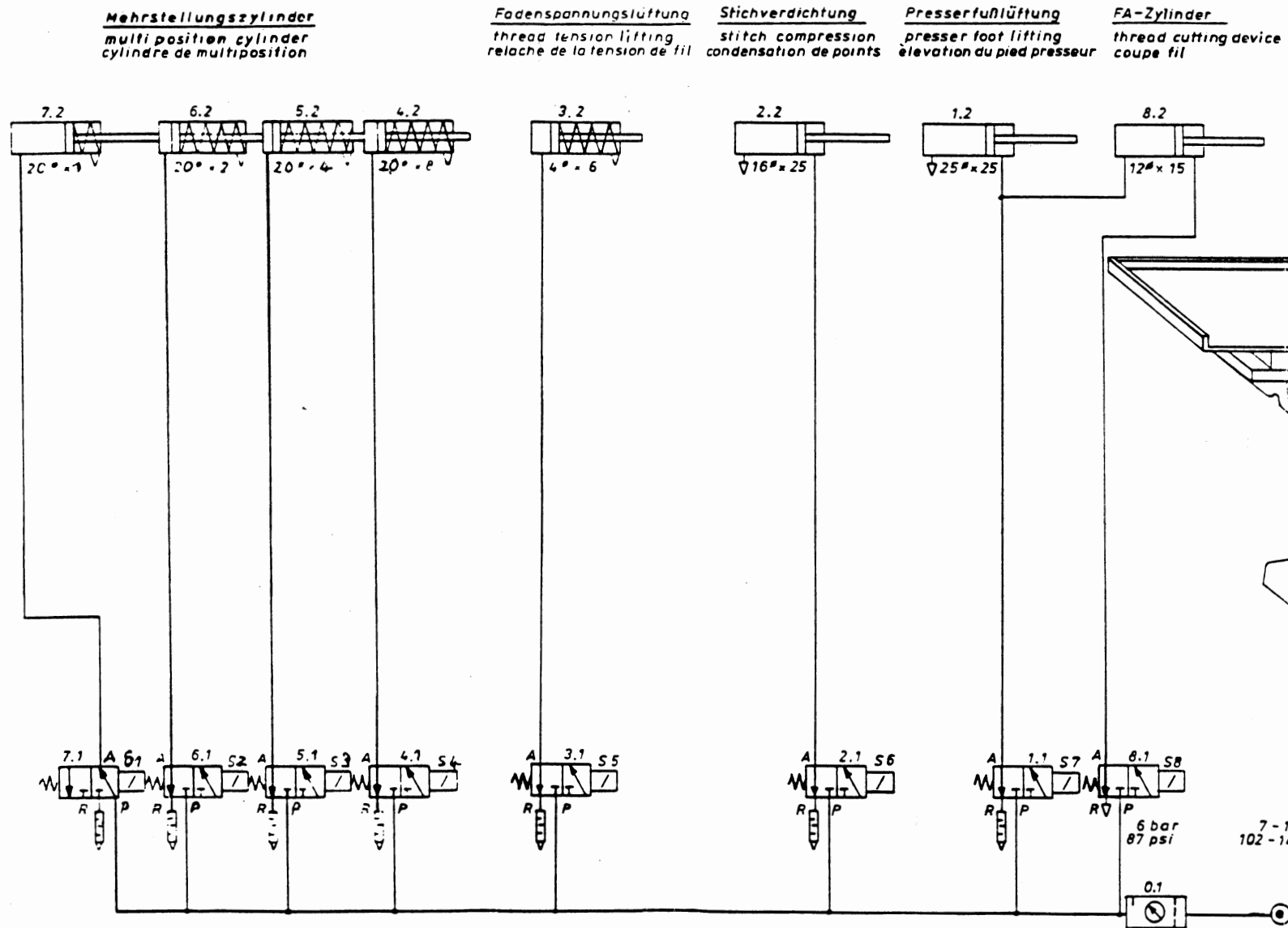

Lageplan
 locating plan
 plan de position

Datum: 1.06.85 Blatt: 1 Zeichner: K. 550-16-5u6	Pneumatik Schaltplan pneumatic circuit plan schema des pneumatiques Kl. 550-16-5u6	Blatt-Nr.: 550-Pldef-18-02 Zeichner: K. 550-16-5u6
Kochs Adler AG Bielefeld		Blatt-Nr.: 550-Pldef-18-01