

Teileliste und Naehleinrichtungen
Parts List and Sewing Equipment

H868

DÜRKOPP ADLER AG

Postfach 17 03 51, D-33703 Bielefeld • Potsdamer Str. 190, D-33719 Bielefeld
Telefon +49 (0) 5 21/ 9 25-00 • Telefax +49 (0) 5 21/ 9 25 24 35 • www.duerkopp-adler.com

Ausgabe / Edition: 08/2016	Aenderungsindex Rev. index: 04.0	Printed in Czech Republic	Teile-Nr./Part.-No.: 0791 868830
--------------------------------------	--	---------------------------	--

Alle Rechte vorbehalten.

Eigentum der Dürkopp Adler AG und urheberrechtlich geschützt. Jede, auch auszugsweise Wiederverwendung dieser Inhalte ist ohne vorheriges schriftliches Einverständnis der Dürkopp Adler AG verboten.

All rights reserved.

Property of Dürkopp Adler AG and copyrighted. Reproduction or publication of the content in any manner, even in extracts, without prior written permission of Dürkopp Adler AG, is prohibited.

Copyright © Dürkopp Adler AG - 2016

H868

Inhaltsverzeichnis	Tafel / Table	Contents
Armwelle	1	Upper shaft
Antrieb Arm- und Unterwelle, Rastkupplung	2	Upper and bottom shaft drive, Safety clutch
Fadenhebel	3	Thread lever
Antrieb Nadeltransport	4	Needle feed drive
Alternierender Obertransport mech.	5	Alternating foot top feed mech.
Antrieb Untertransport	6	Bottom feed drive
Untertransport	7	Bottom feed
Fusslueftung mech.	8	Top roller lift mech.
Fuesslueftung pneu.	9	Top roller lift pneu.
Hubverstellung	10	Skipping foot lift pneumatic
Transportsaeule	11	Middle post
Greifer XXXL mit Spule	12	Hook XXXL with bobbin
Greifersaeule rechts	13	Hook post right
Greifersaeule links	14	Hook post left
Luefterfinger, Saeulendeckel	15	Releasing hook, Hook cover
Spuler	16	Winder
Spannungsplatte Einnadel pneu., Elektronisches Handrad	17	Tension plate 1 needle pneu., Electronic hand wheel
Spannungsplatte Zweinadel pneu. Elektronisches Handrad	18	Tension plate 2 needles pneu. Electronic hand wheel
Stichverstellung 2 Stichlaengen, Verriegelung mech., pneu.	19	Stitch adjustment 2 stitch lengths, Backtacking mech., pneu.
Magnetventileinheit, Taster	20	Solenoid valve unit, Push-buttons
Zentralschmierung, Oelstandanzeige	21	Central lubrication, Maintenance indicator
Arm, Fadenfuehrung, Integr. Diodennaehleuchte	22	Arm, Thread guide, Sewing light LEDs
Armdeckel CLASSIC	23	Arm cover CLASSIC
Grundplatte	24	Bed plate
Naehleuchte Halogen	25	Sewing lamp halogen
Teilesatz fuer DAC Classic	26	Parts set for DAC Classic
Gestell	27	Stand
Wartungseinheit	28	Maintenance unit
Beipack	29	Accessories
Eindiodennaehleuchte	30, 31	Sewing lamp LED
Nahtmittenfuehrung	32	Seam centre guide
Kantenanschlag schwenkbar	33	Hinged edge guide
Kantenanschlag		Edge guide
Bandfuehrung	34	Tape guide
Werkzeug M-Type	35	Tool kit M-Type
Speicher extern		Memory external
Elektropneum. Nadelkuehlung	36	Electropneum. needle cooling
Index		Index
Befestigungsteile fuer Naehleinrichtung		Fastening parts for sewing equipment
Naehleinrichtungen		Sewing equipment
Bauschaltplan		Wiring diagram
Pneu. Geraeteplan		Pneumatic circuit plan

H868



Einnadel-Maschine
single needle machine



Zweinadel-Maschine
two needle machine

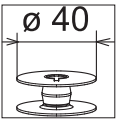

Greifer XXXL
hook XXXL



kleben/stick

N nicht einzeln lieferbar/not available as separate part

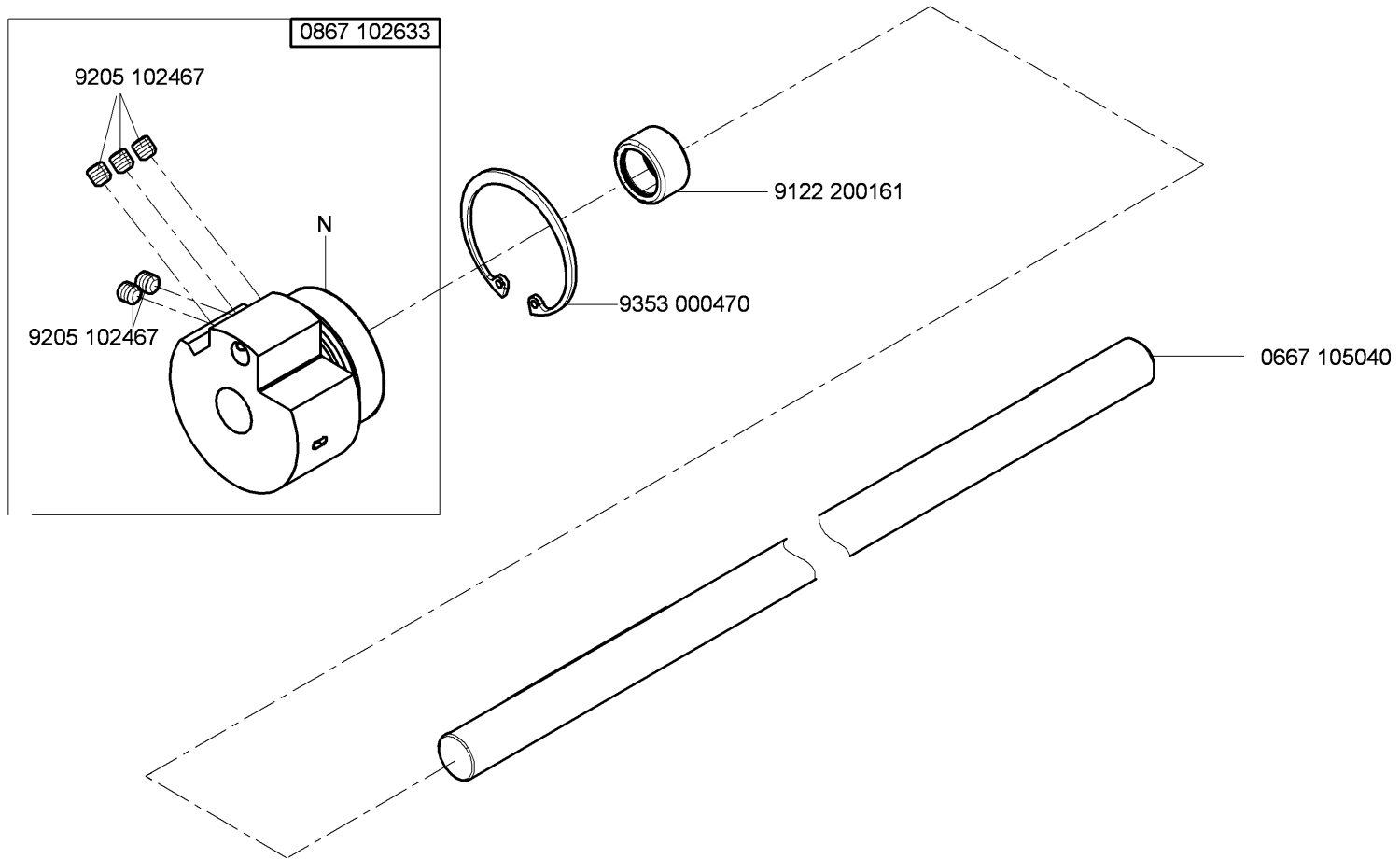

N - nicht als Einzelteil lieferbar
not available as separate part

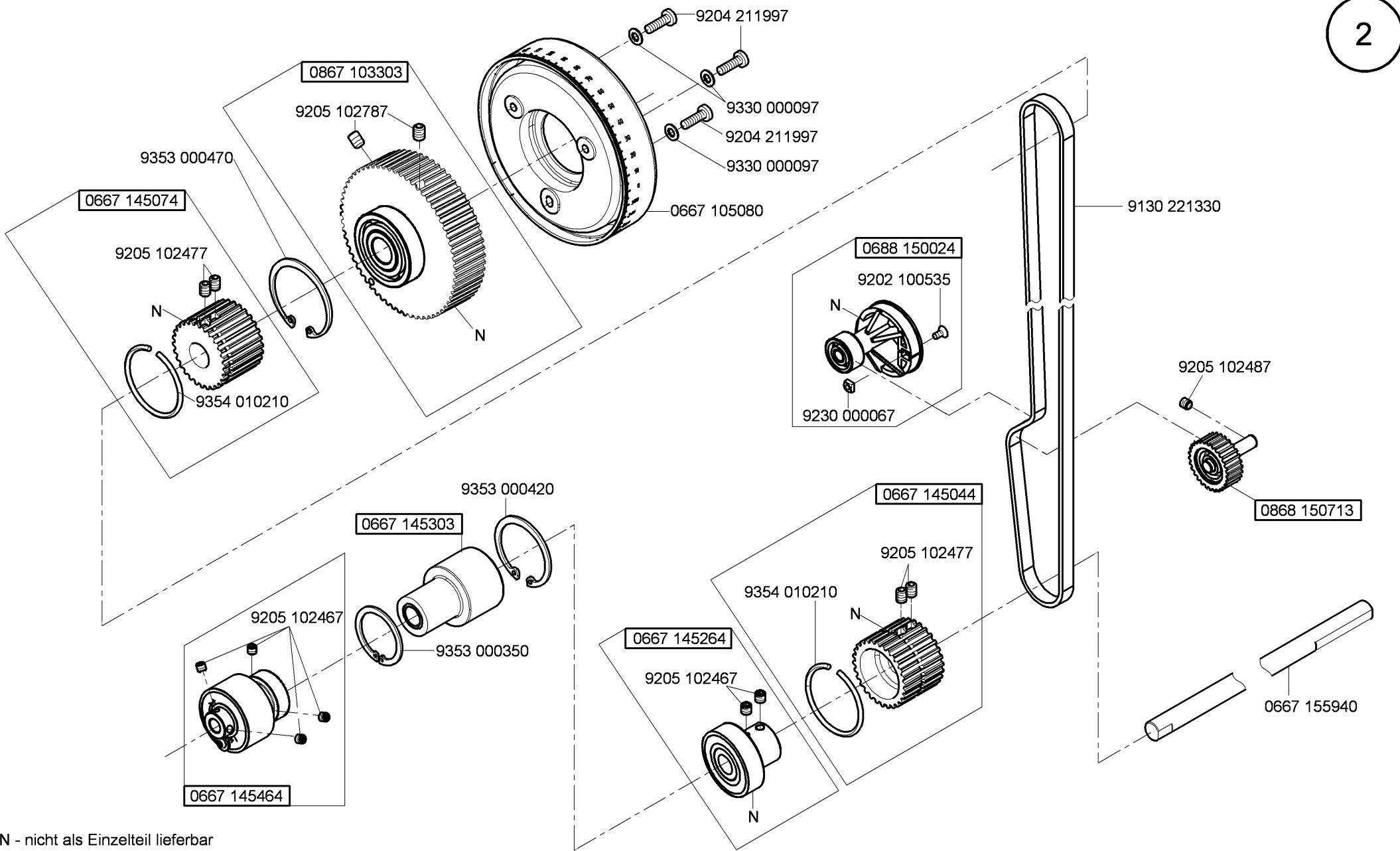

N - nicht als Einzelteil lieferbar
not available as separate part

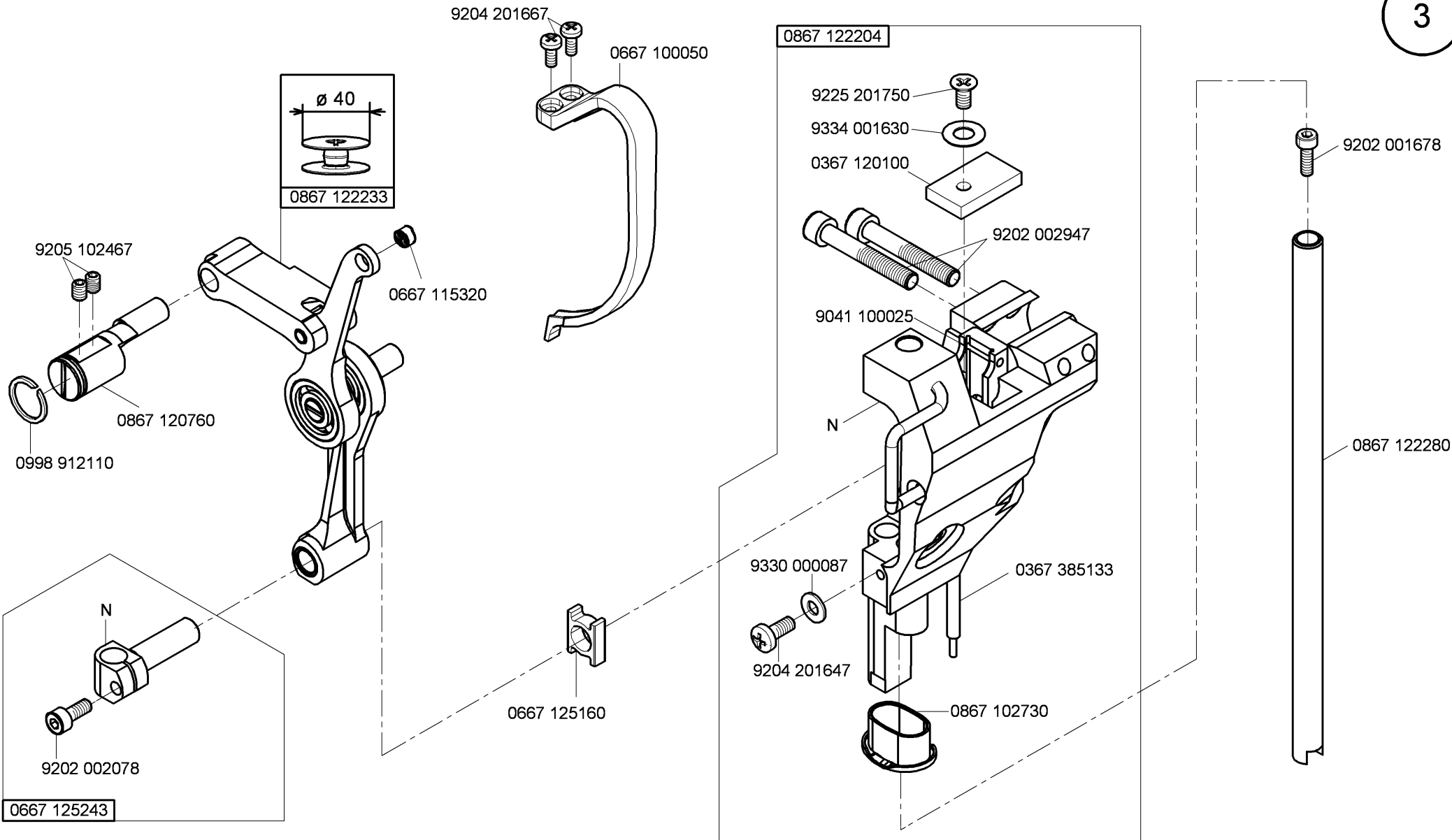

N - nicht als Einzelteil lieferbar
not available as separate part

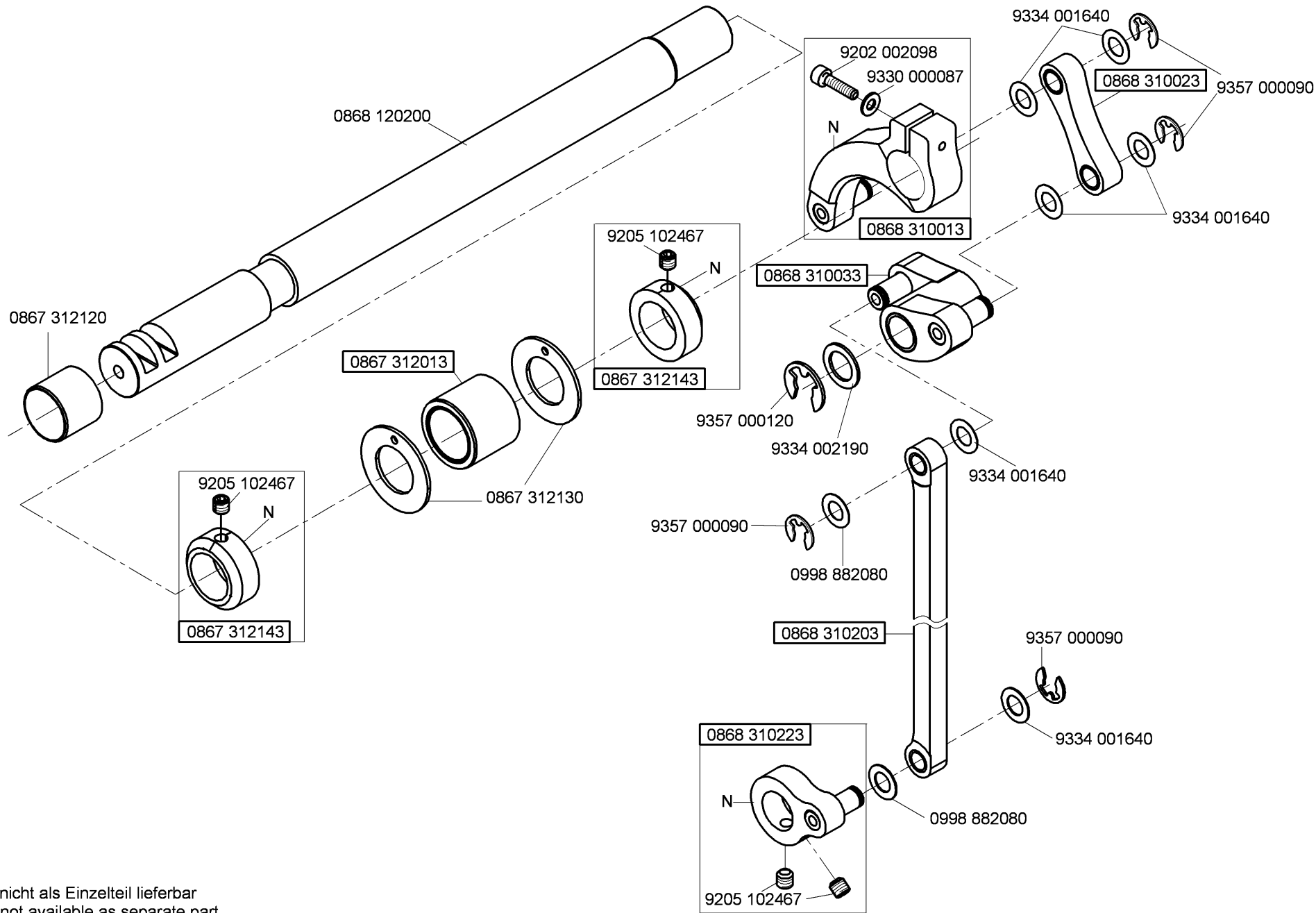

N - nicht als Einzelteil lieferbar
not available as separate part

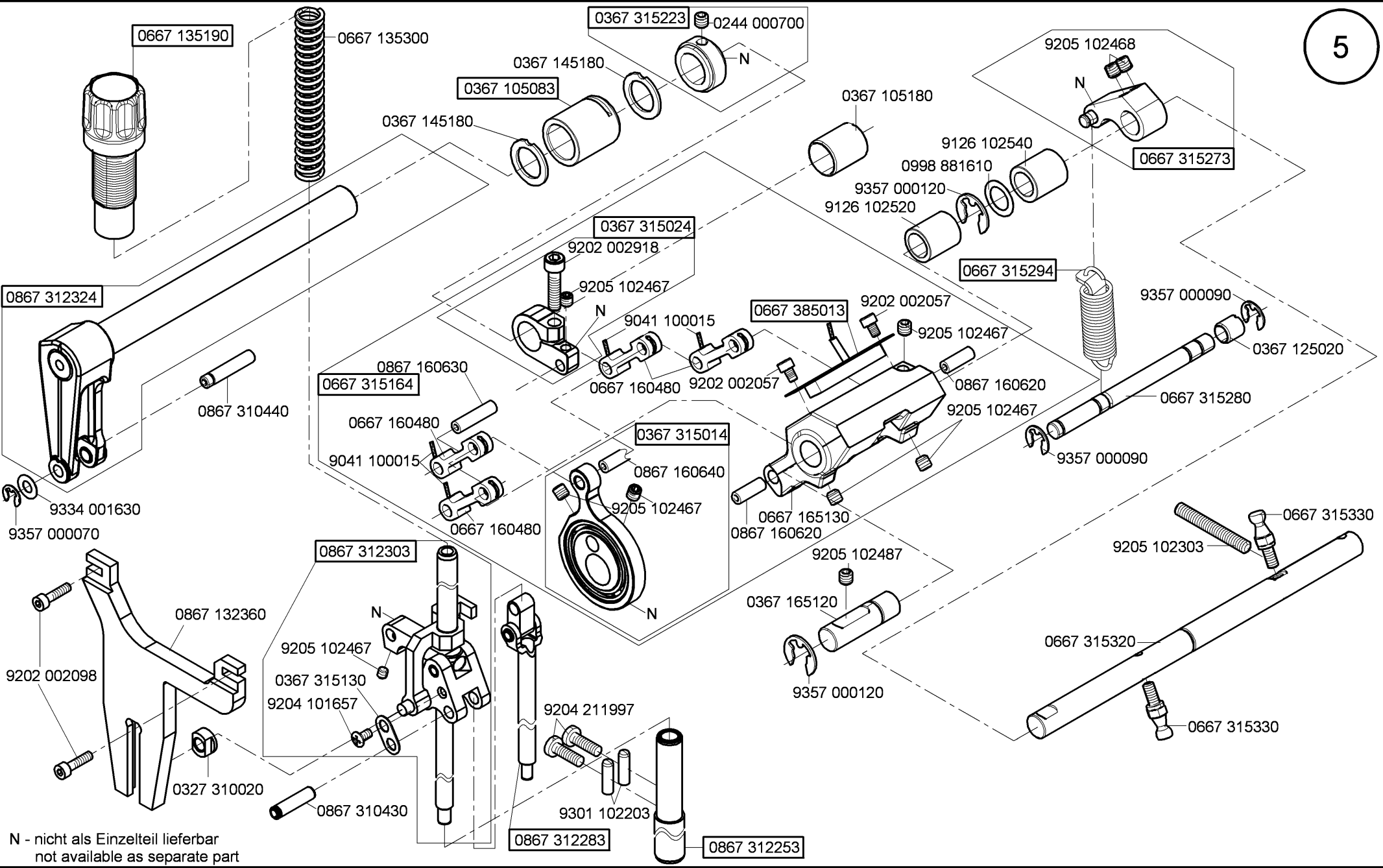

N - nicht als Einzelteil lieferbar
not available as separate part

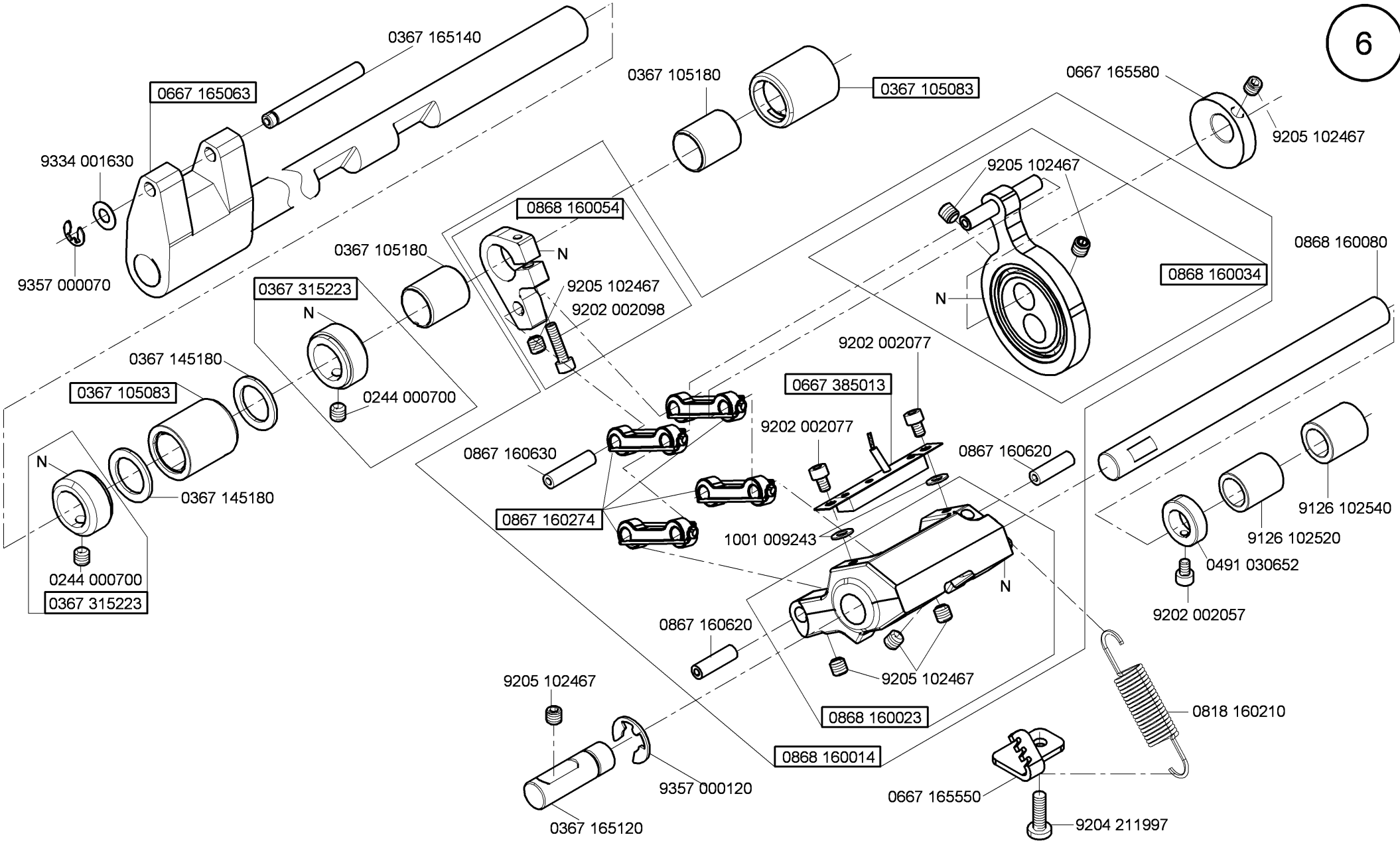

N - nicht als Einzelteil lieferbar
not available as separate part

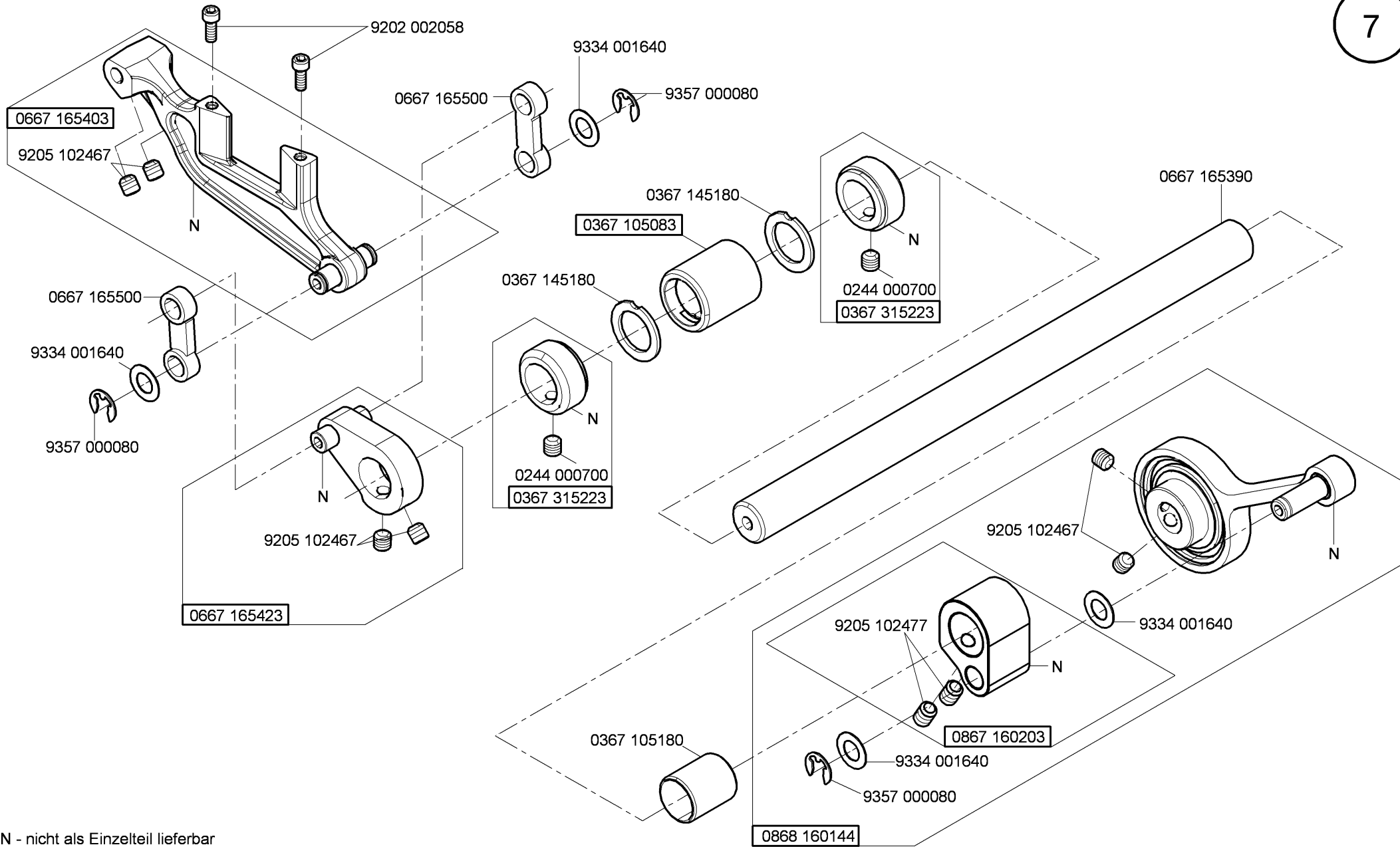

N - nicht als Einzelteil lieferbar
not available as separate part

0868 130144

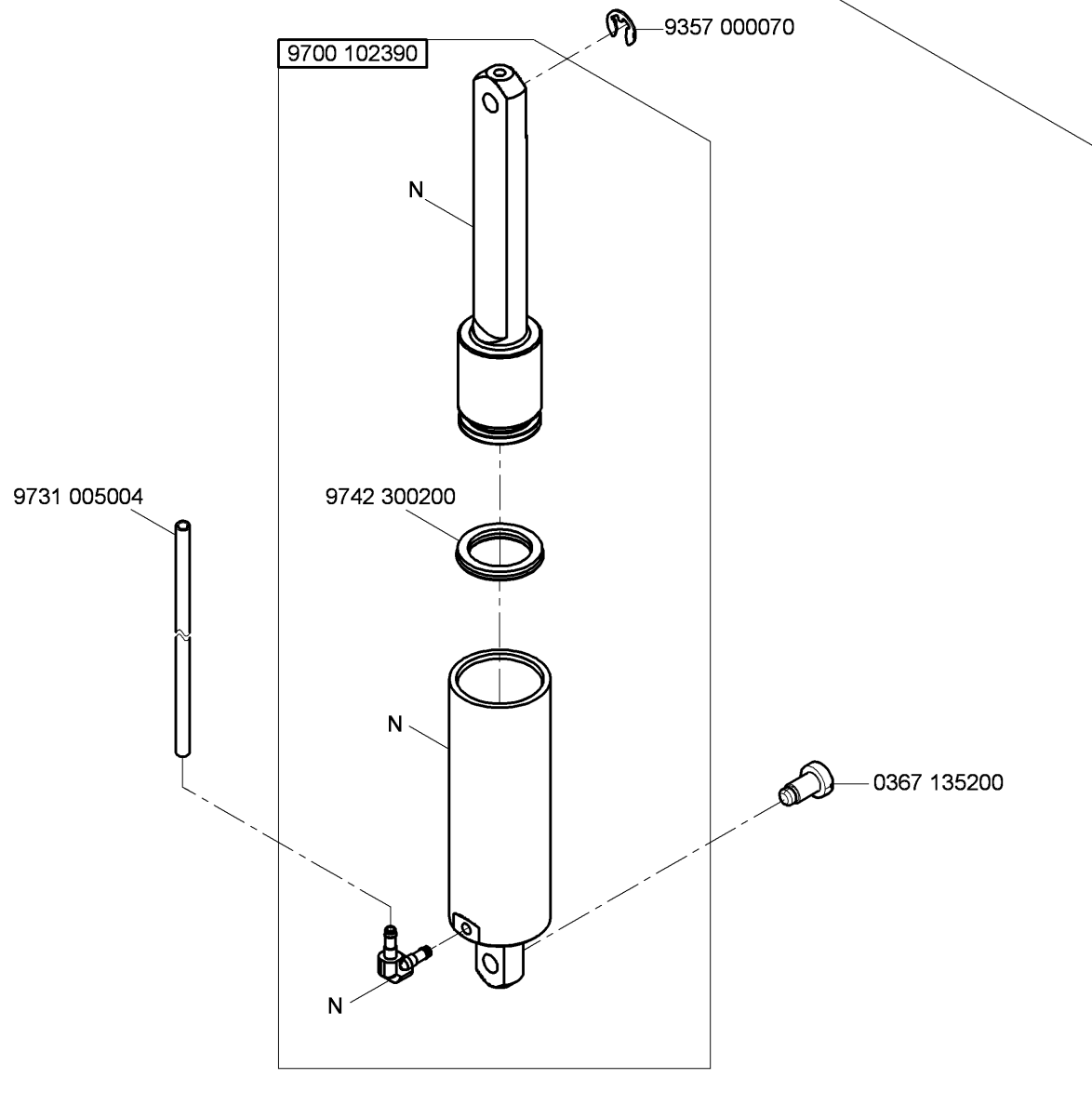

N - nicht als Einzelteil lieferbar
not available as separate part

9880 867120

9880 002005

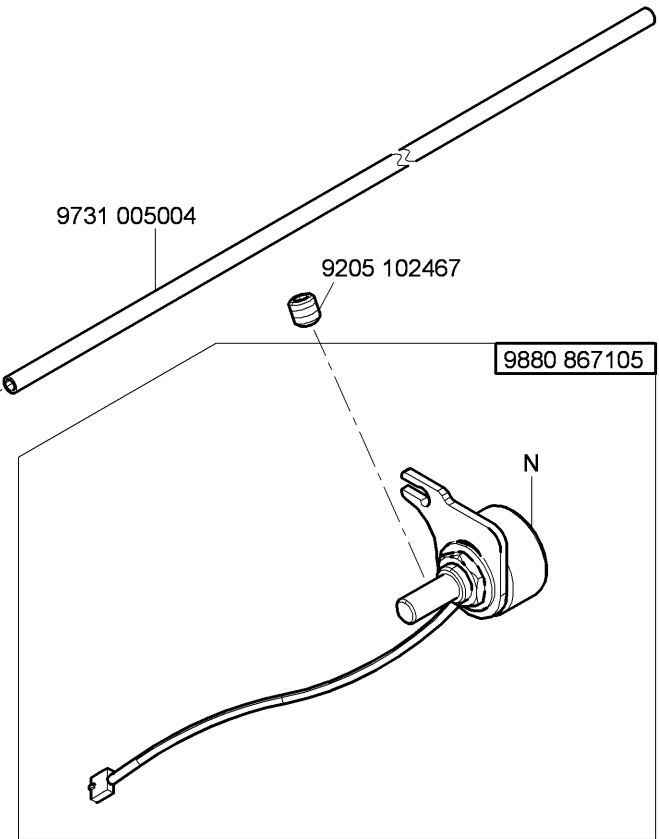
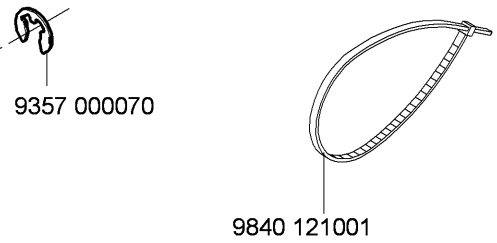
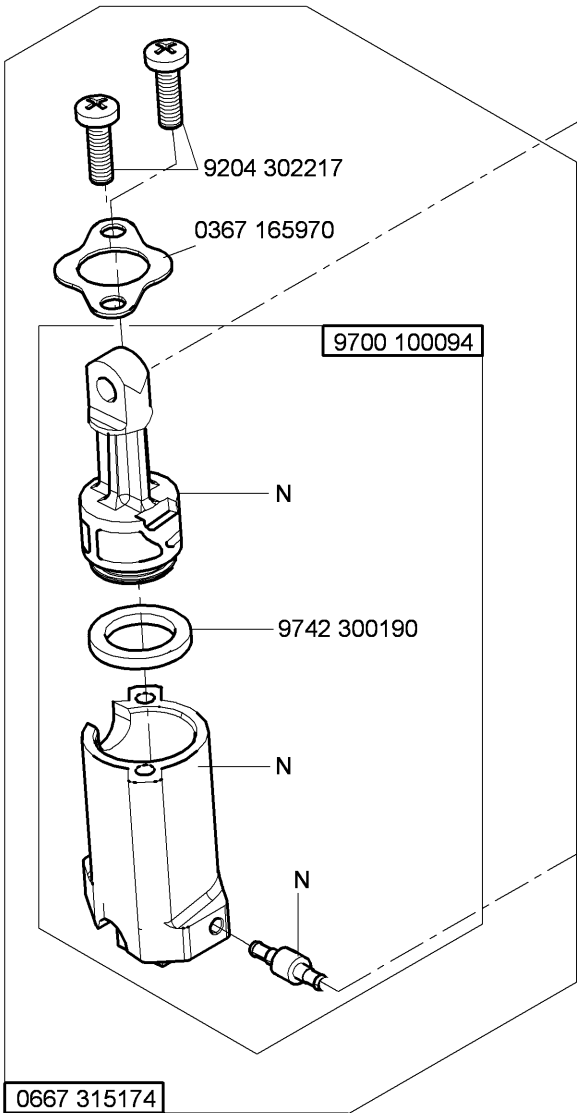
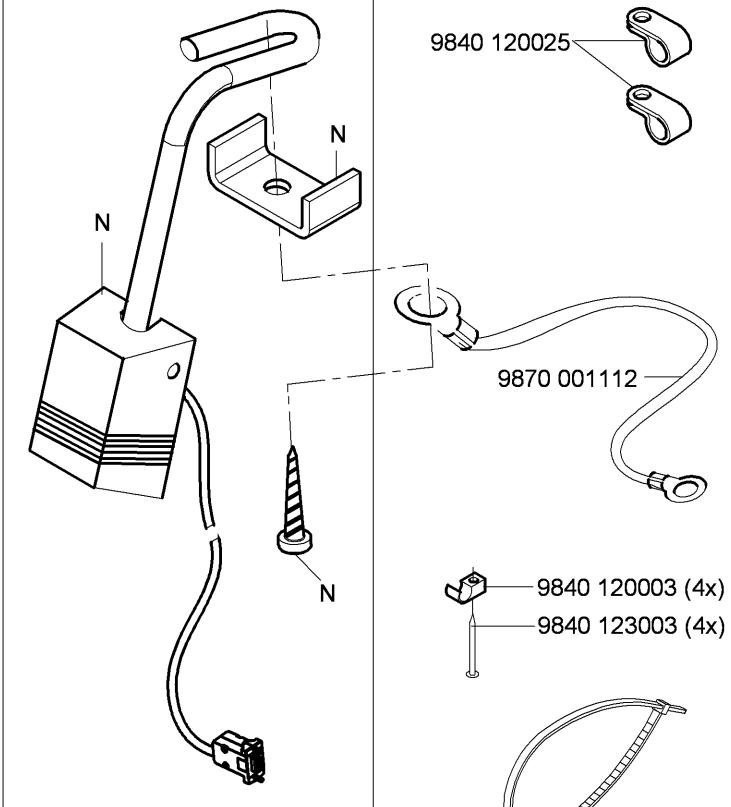

0868 320114

CI.H868 -290361

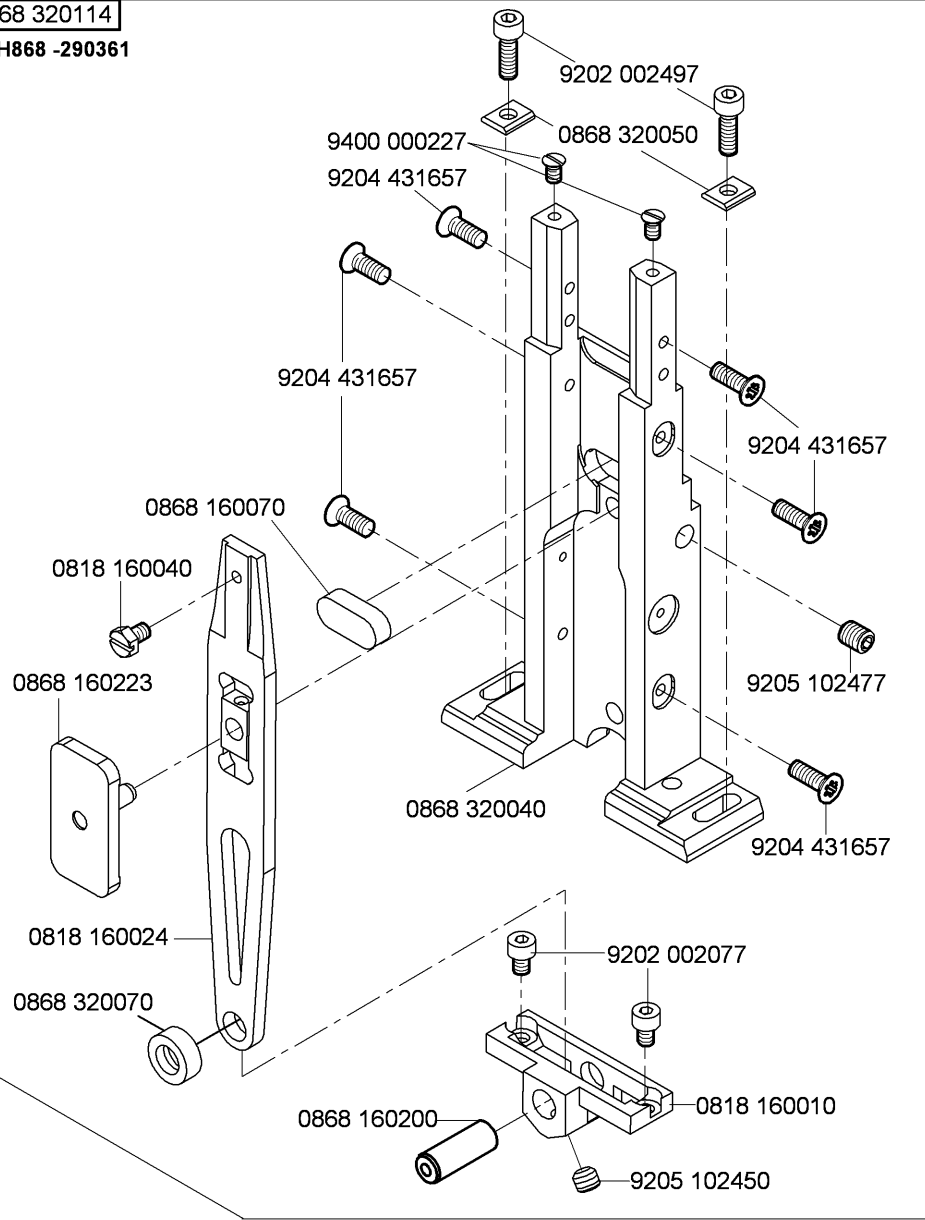

CI.H868 -190361

0868 140040

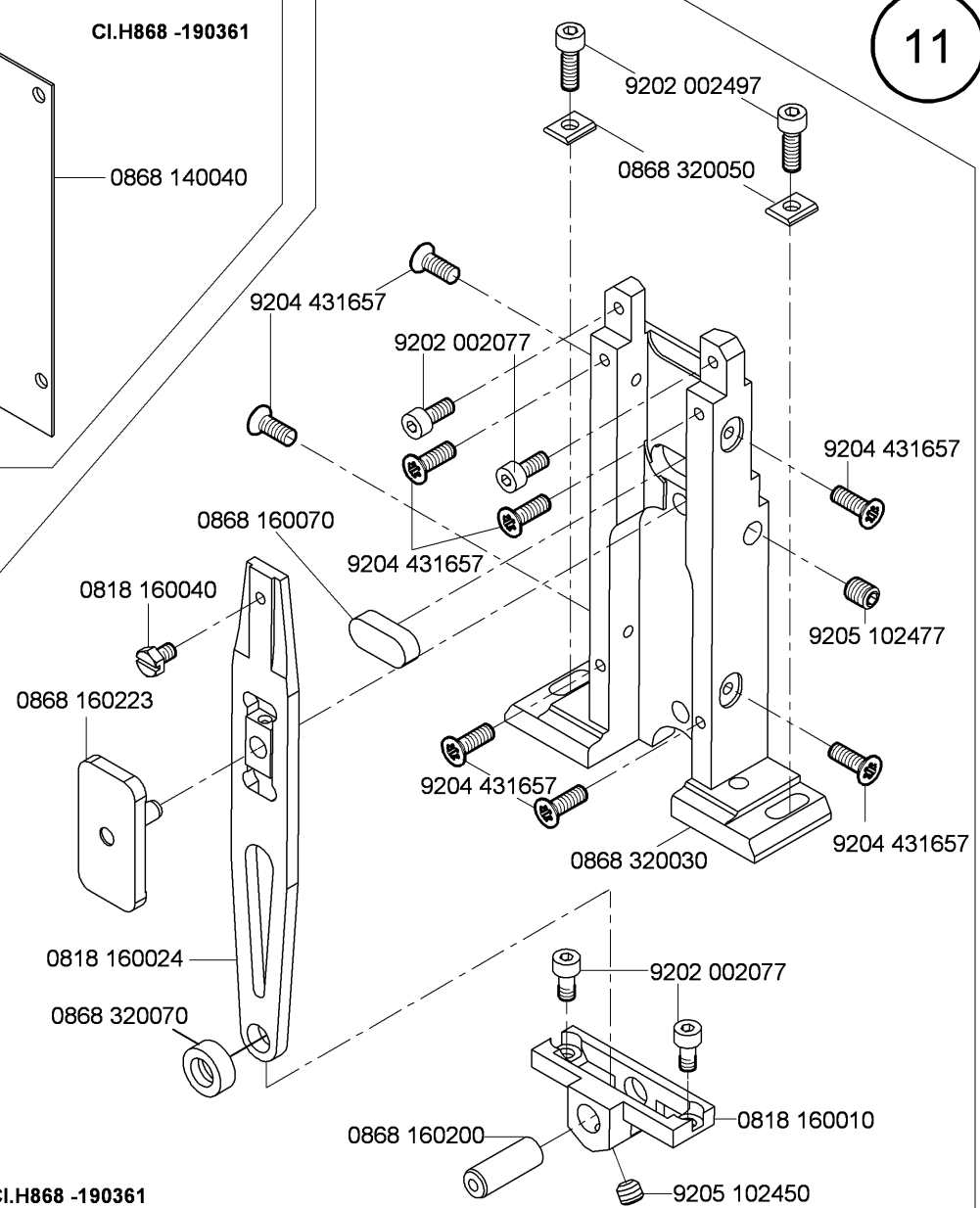

11

CI.H868 -190361

0868 320104

N - nicht als Einzelteil lieferbar
not available as separate part

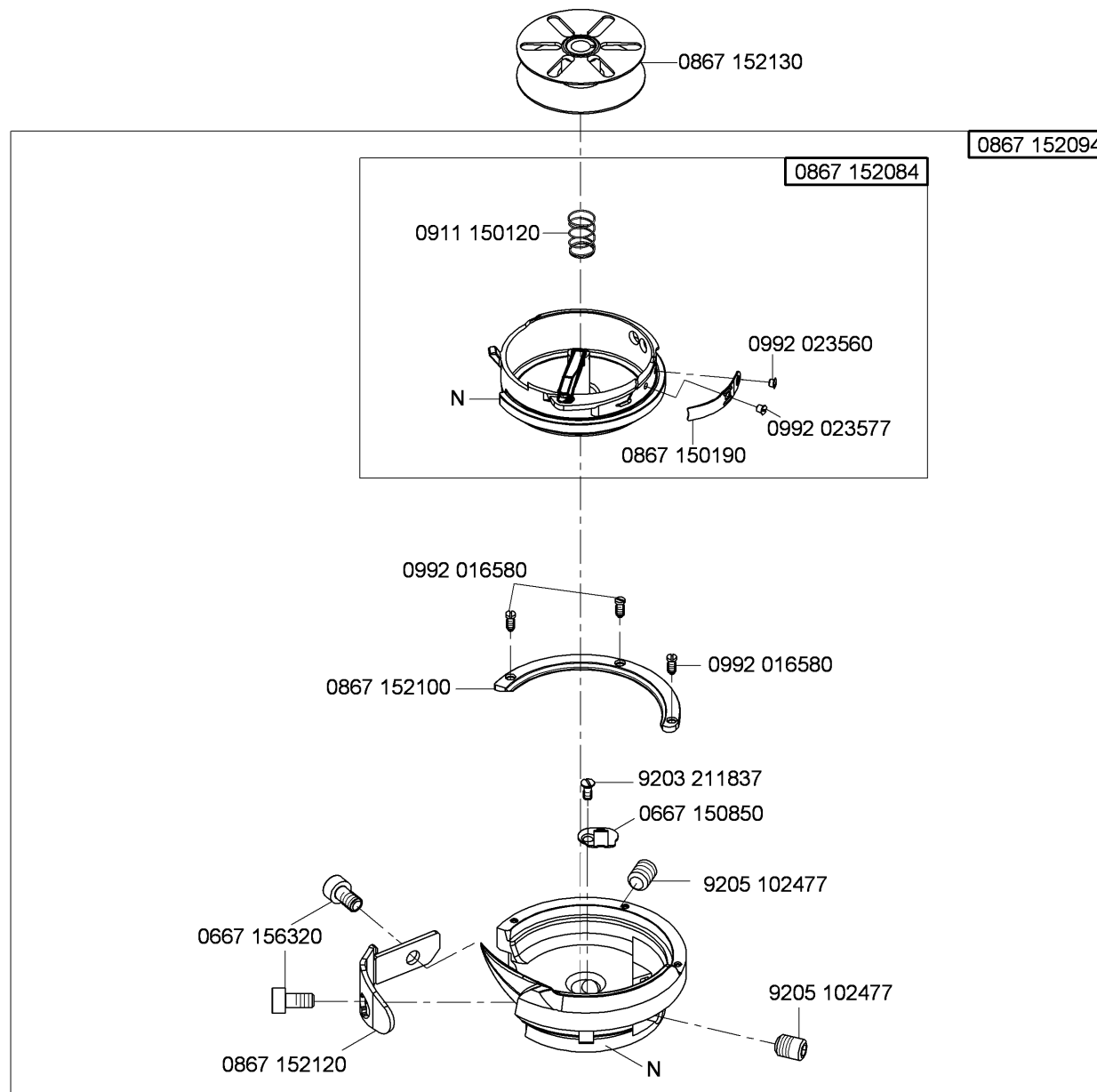
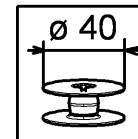

N - nicht als Einzelteil lieferbar
not available as separate part

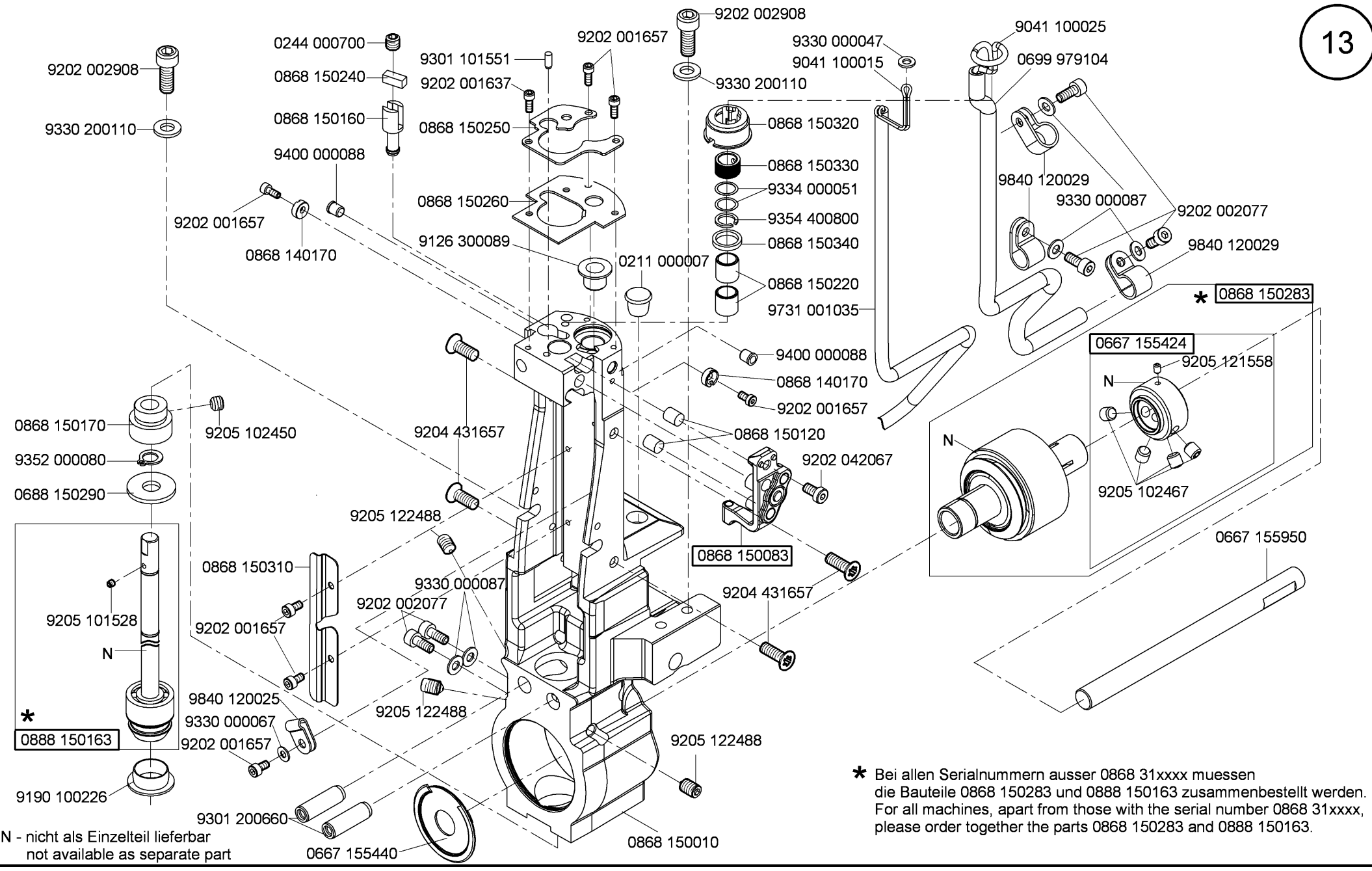

N - nicht als Einzelteil lieferbar
not available as separate part

* Bei allen Serialnummern ausser 0868 31xxxx muessen die Bauteile 0868 150283 und 0888 150163 zusammenbestellt werden.
For all machines, apart from those with the serial number 0868 31xxxx, please order together the parts 0868 150283 and 0888 150163.

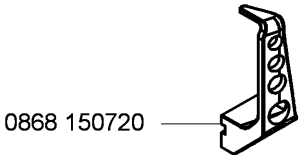
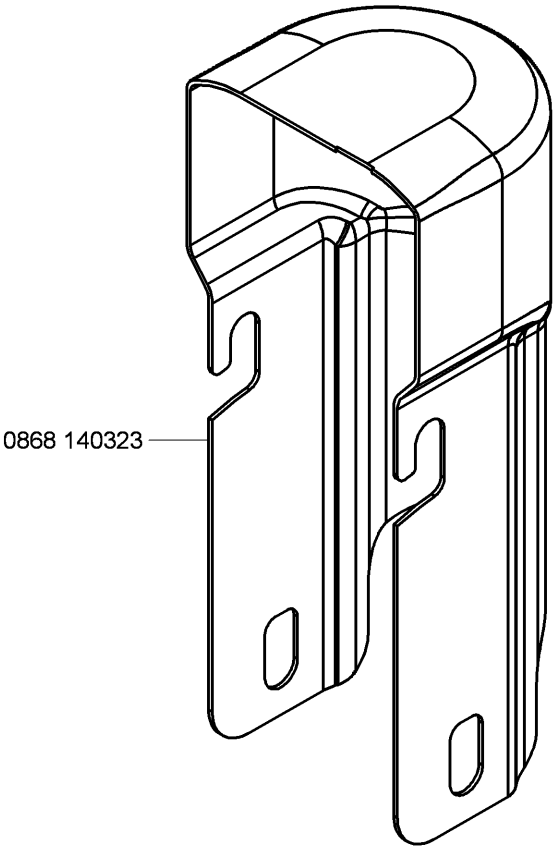
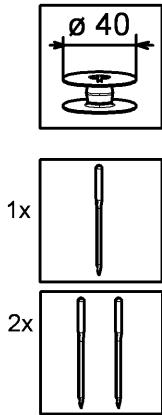

N - nicht als Einzelteil lieferbar
not available as separate part

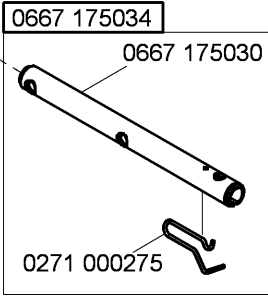
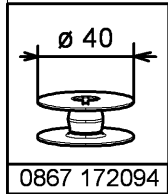
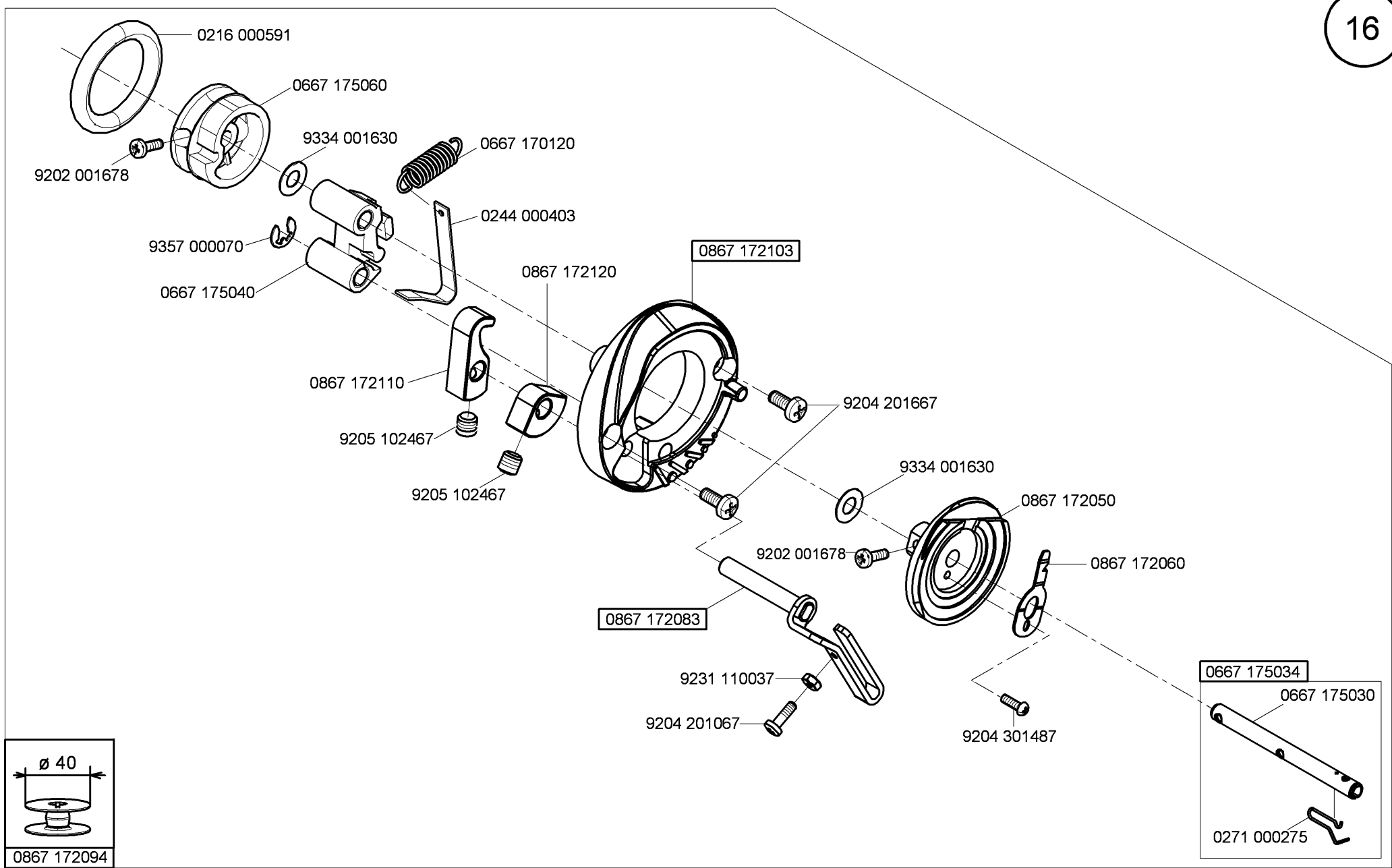

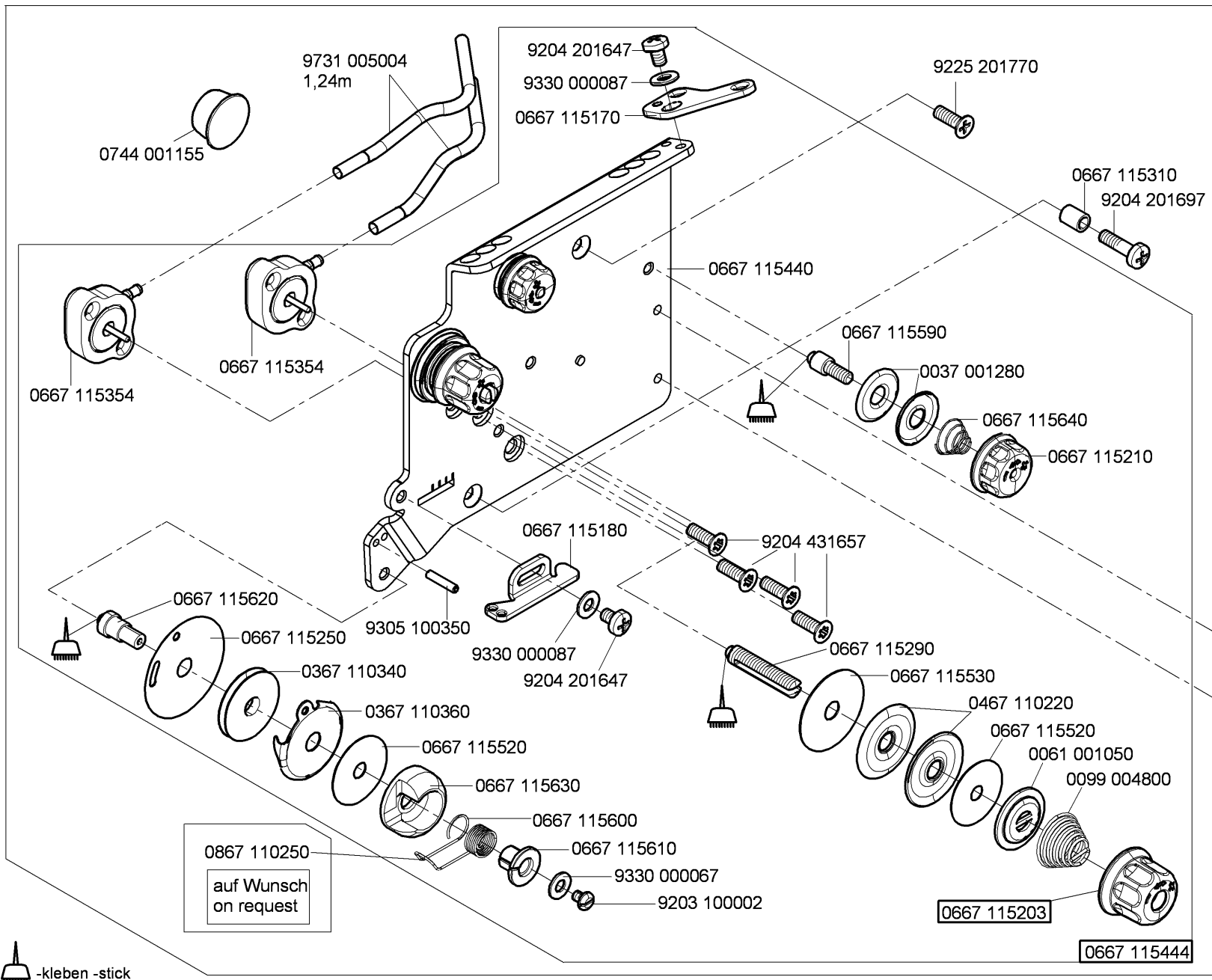

0867 110250
auf Wunsch
on request

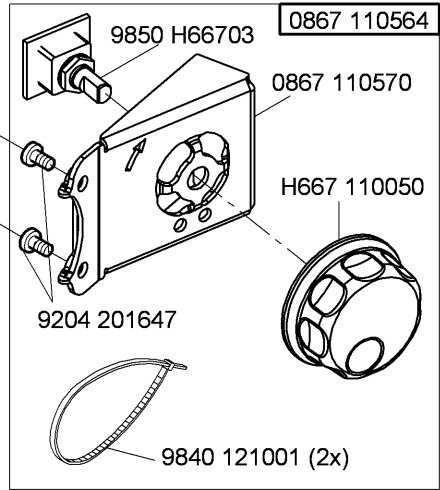

-kleben -stick

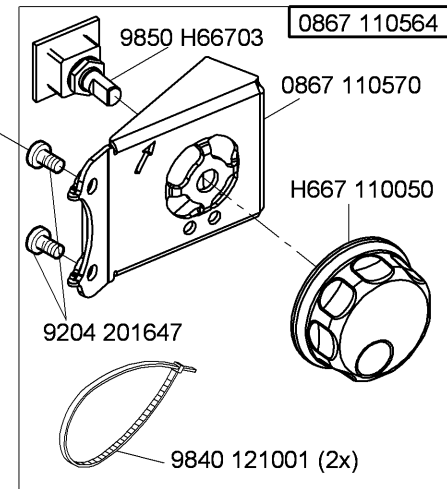
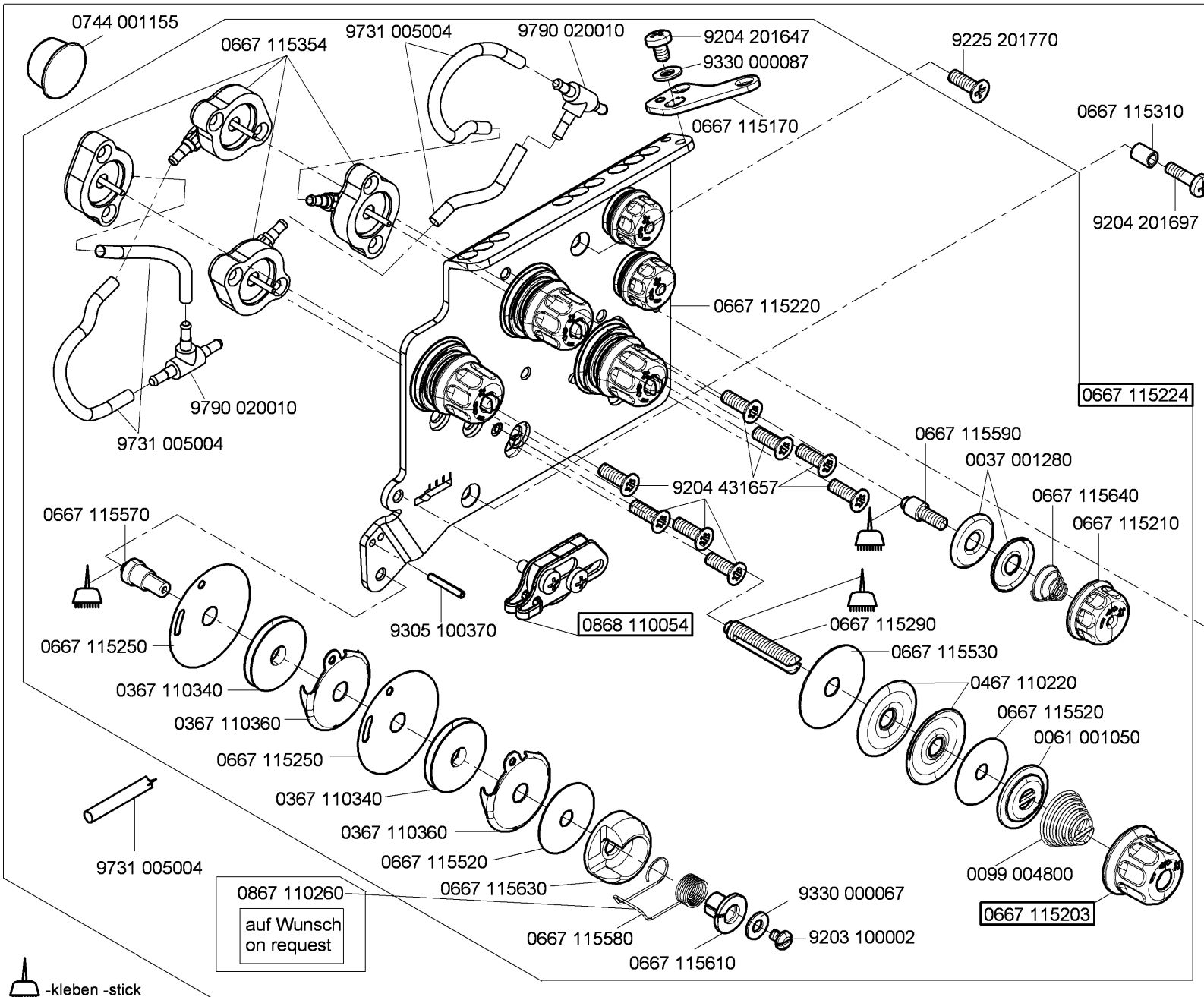

-kleben -stick

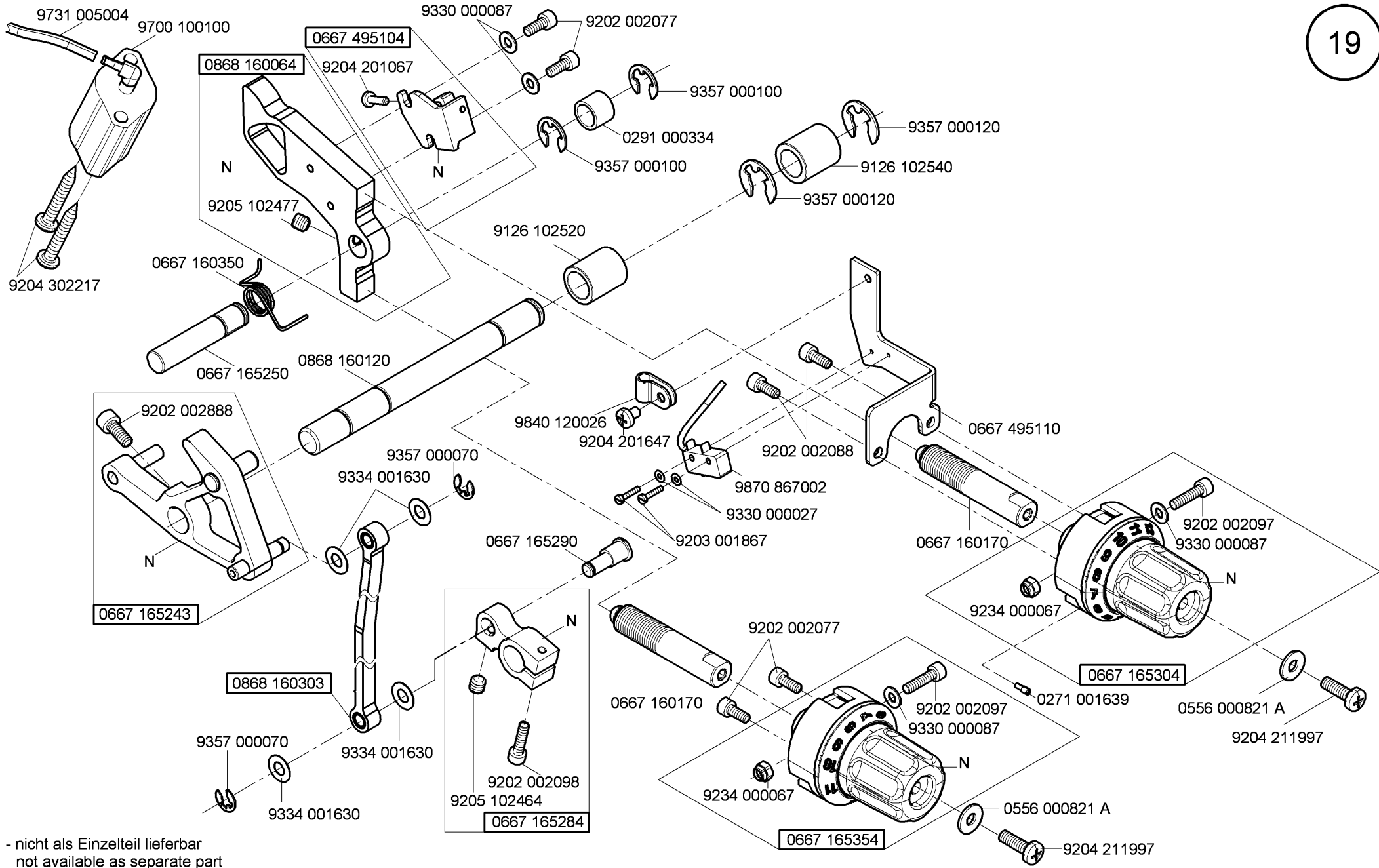

N - nicht als Einzelteil lieferbar
not available as separate part

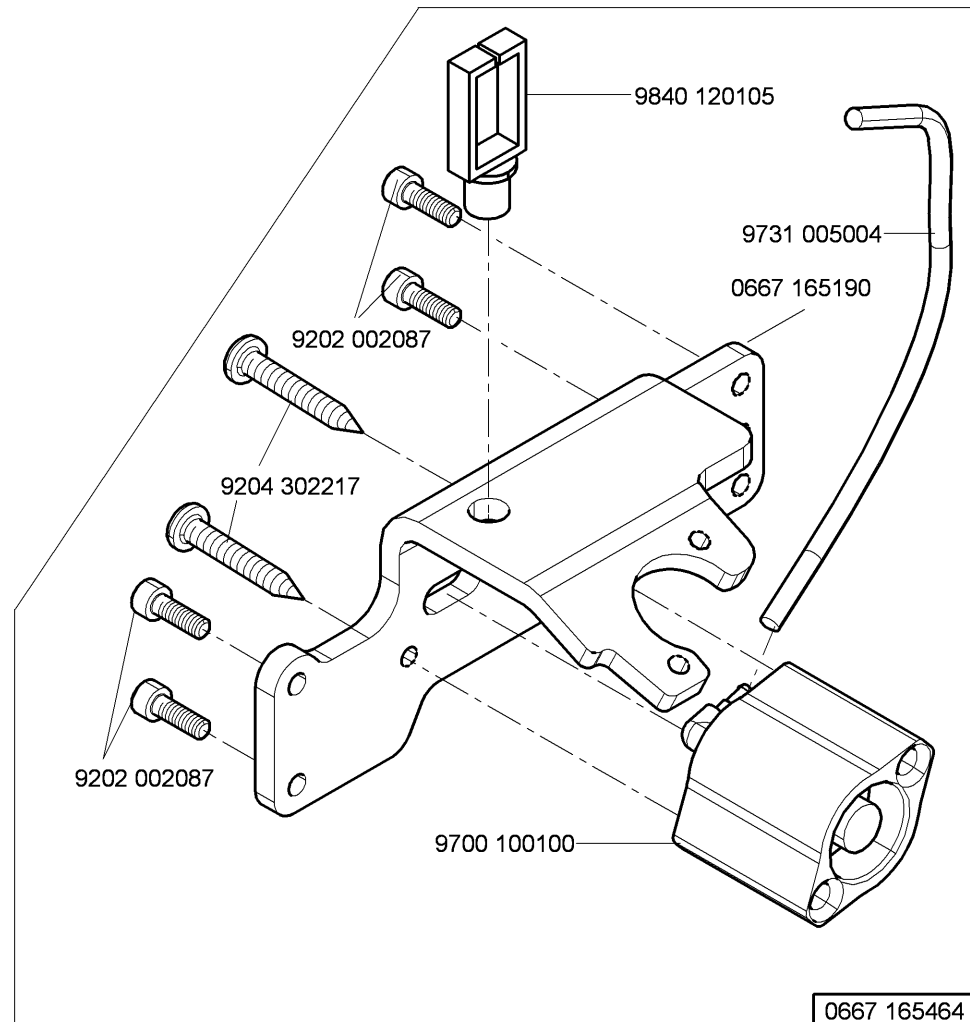
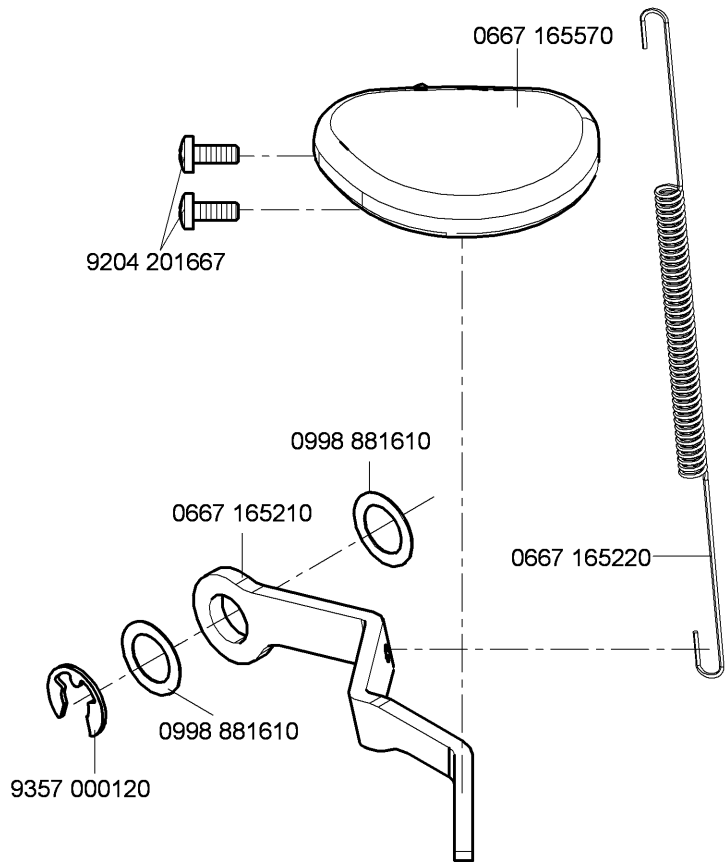

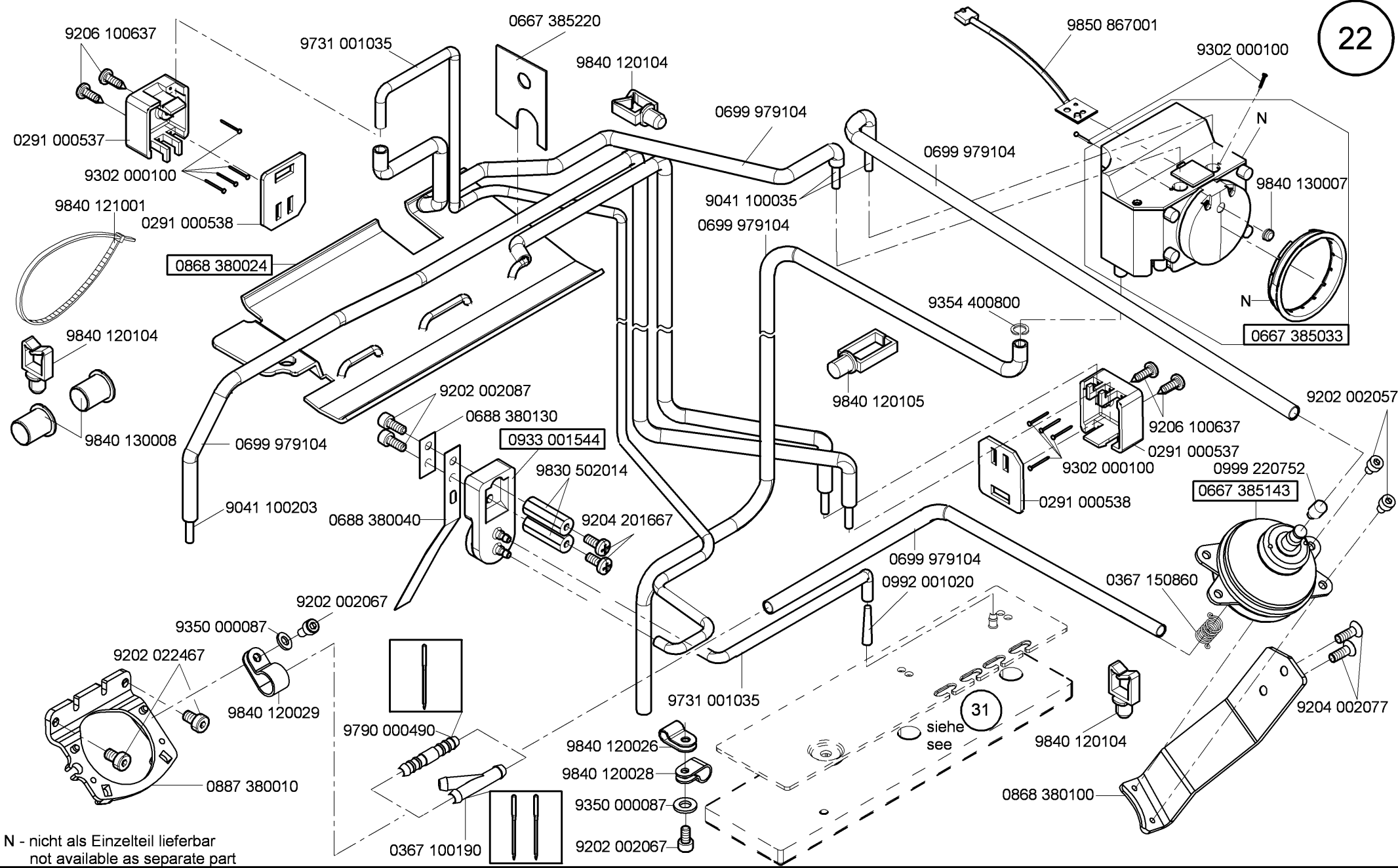

N - nicht als Einzelteil lieferbar
not available as separate part

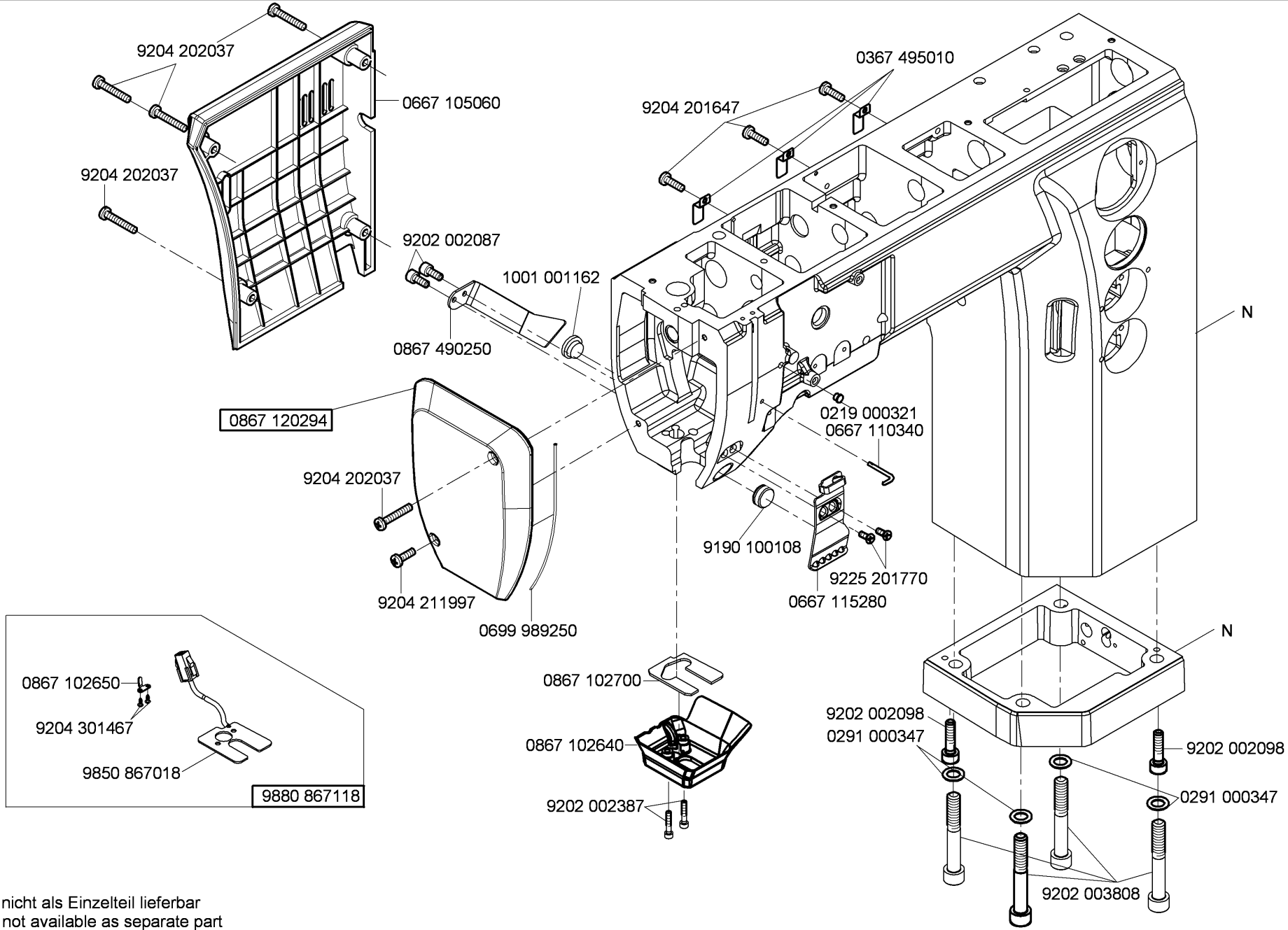

N - nicht als Einzelteil lieferbar
not available as separate part

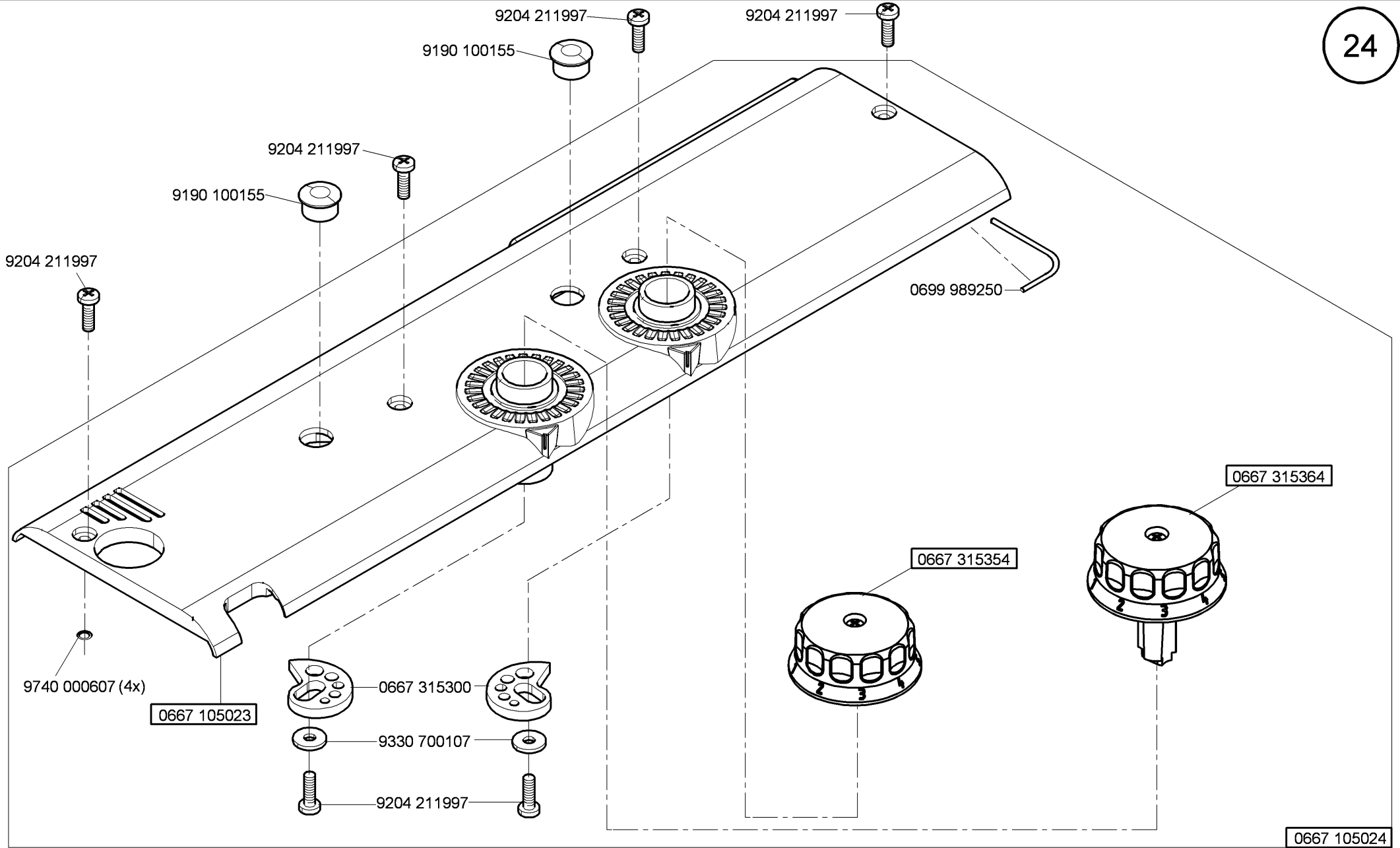

0667 105024

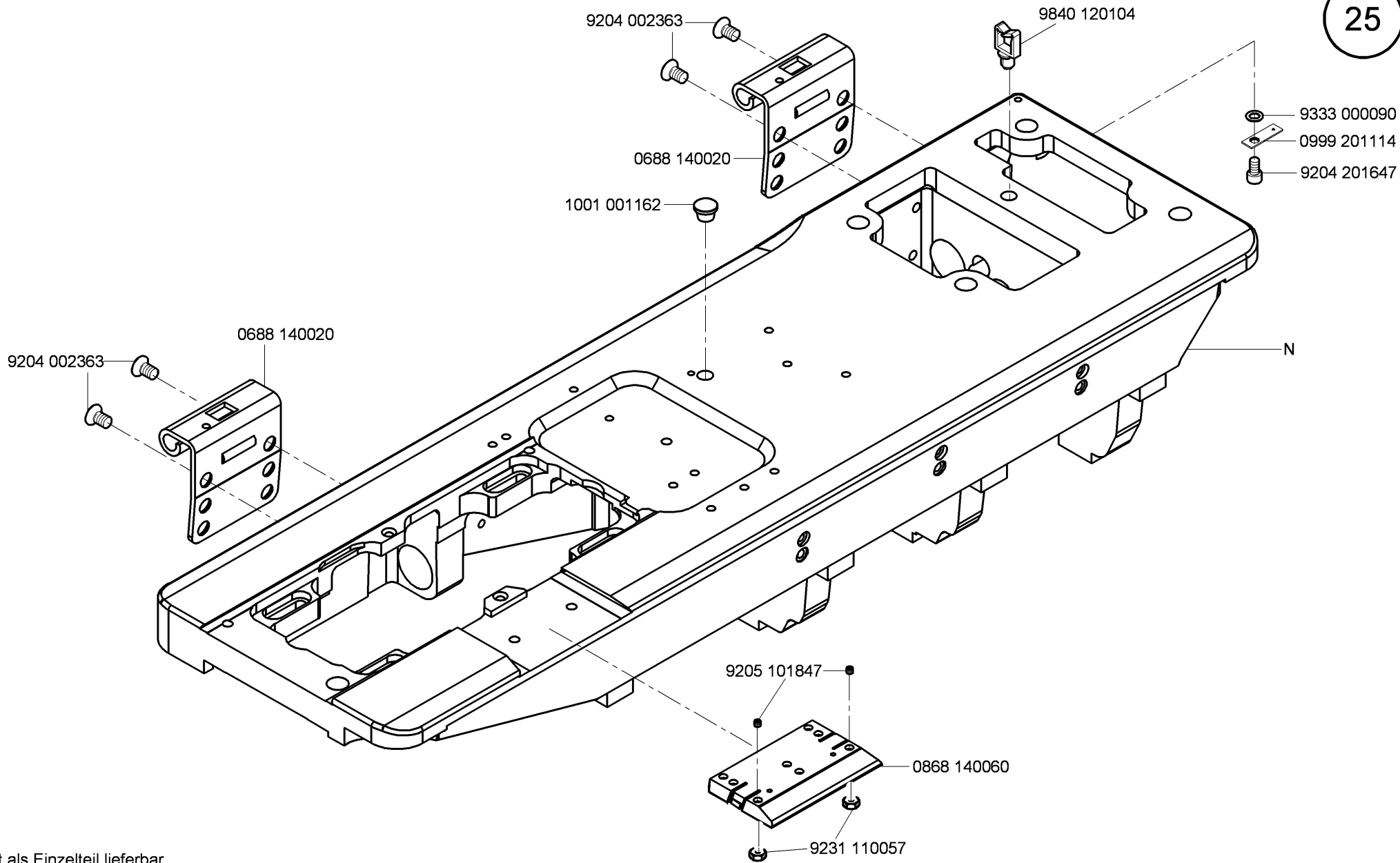

N - nicht als Einzelteil lieferbar
not available as separate part

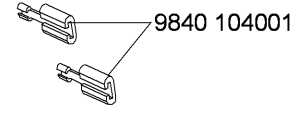
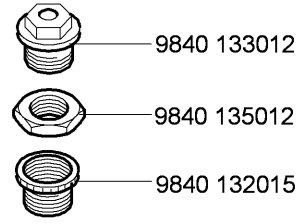
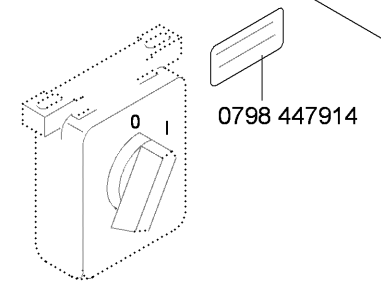
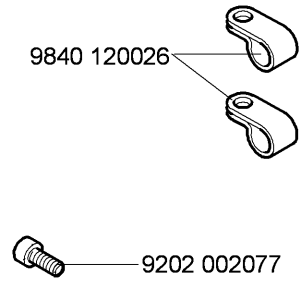
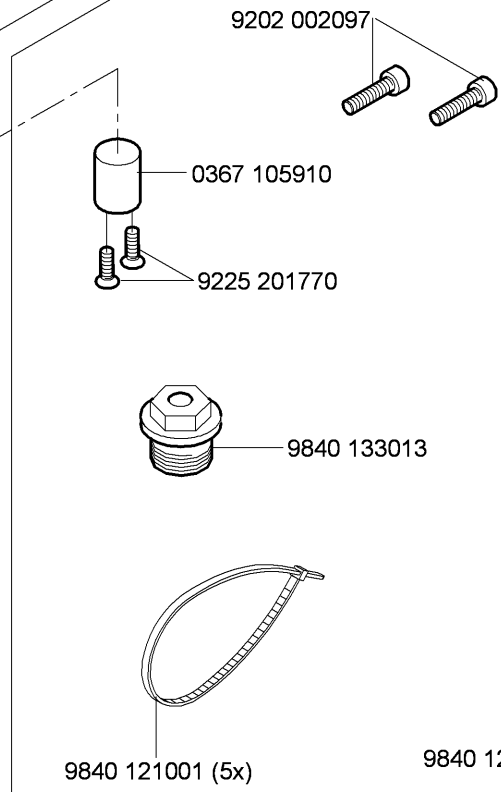
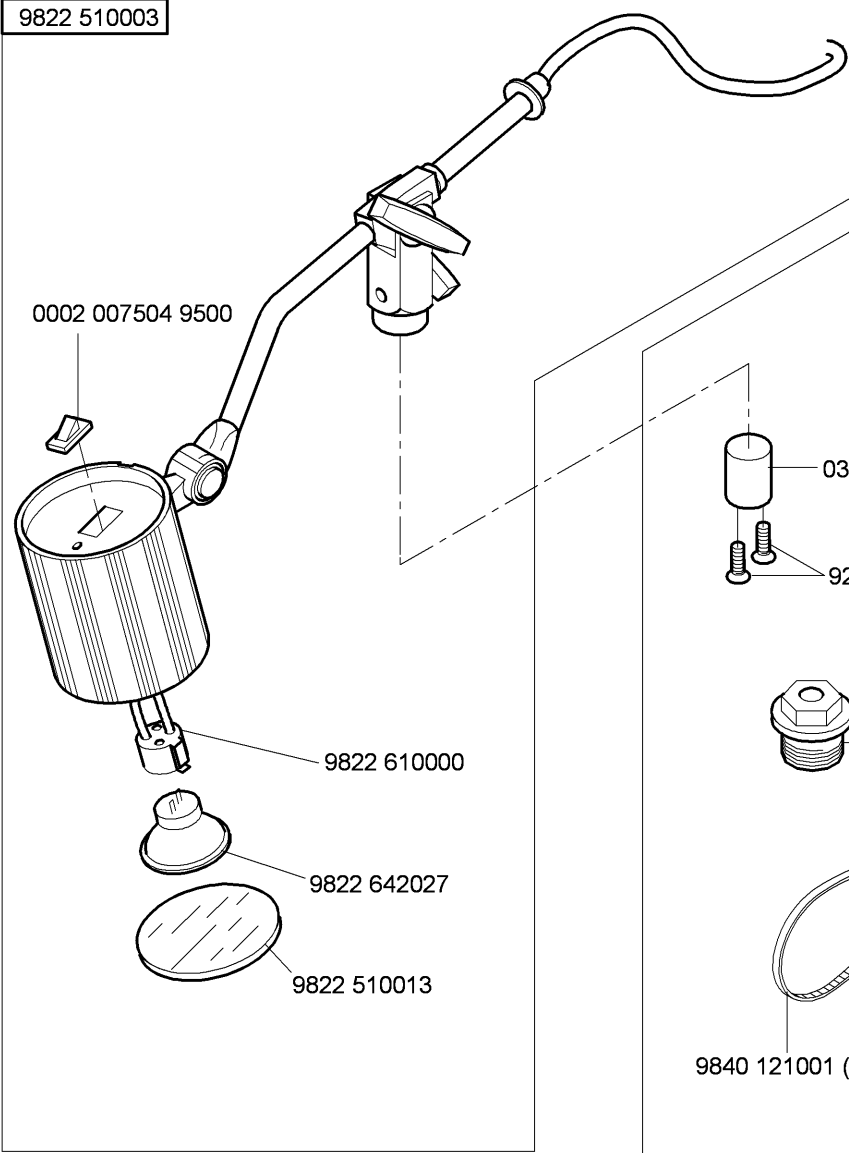

9880 867100

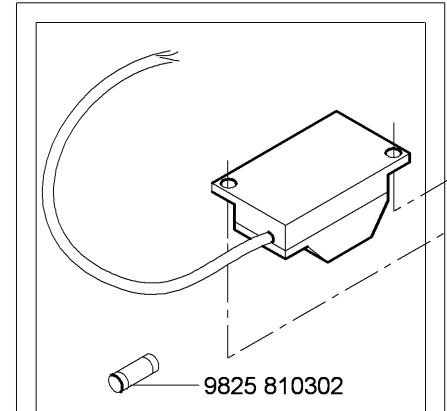
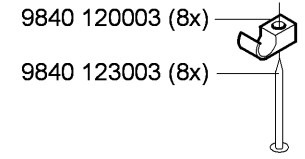

0798 500088

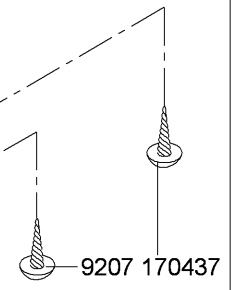

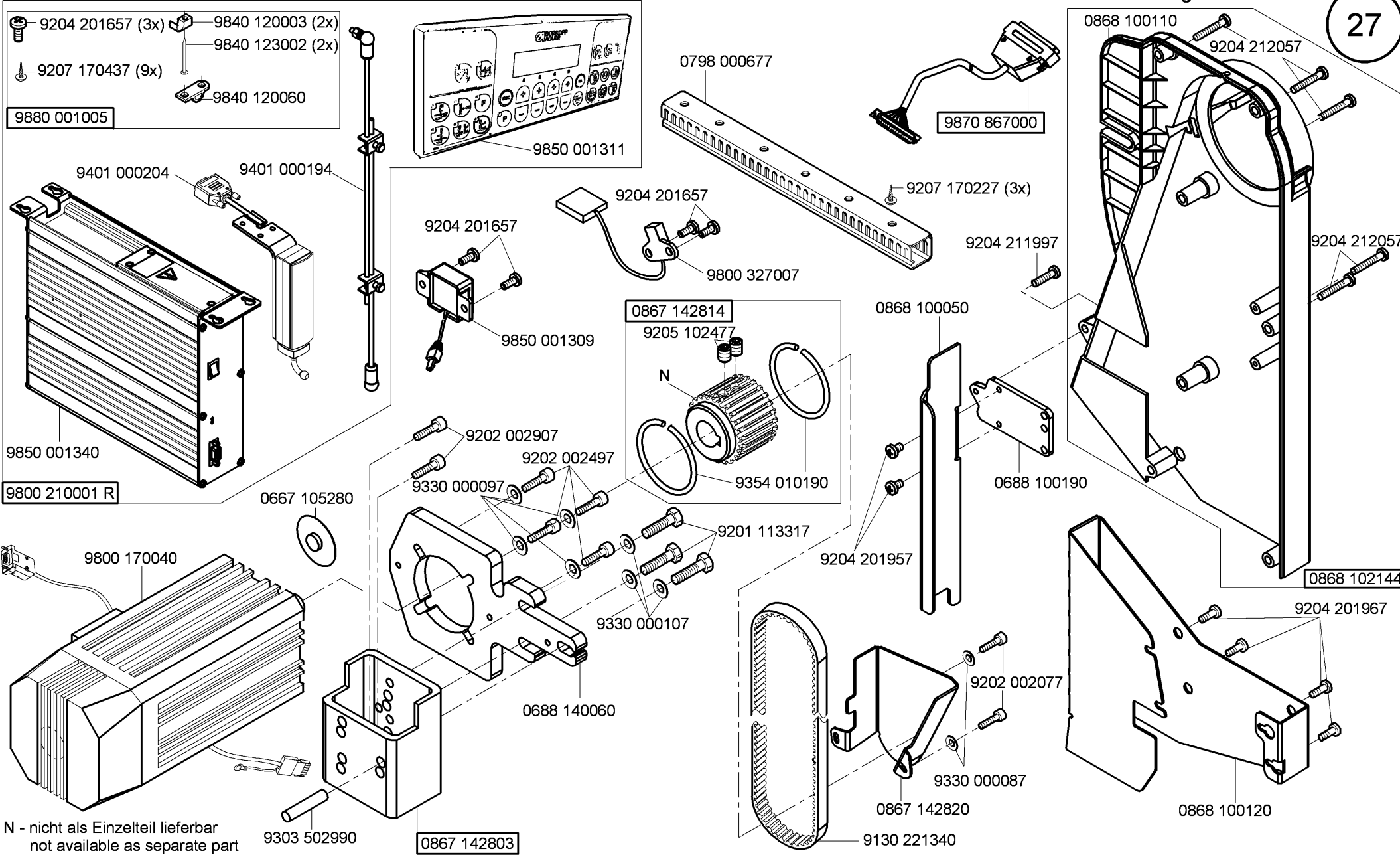

N - nicht als Einzelteil lieferbar
not available as separate part

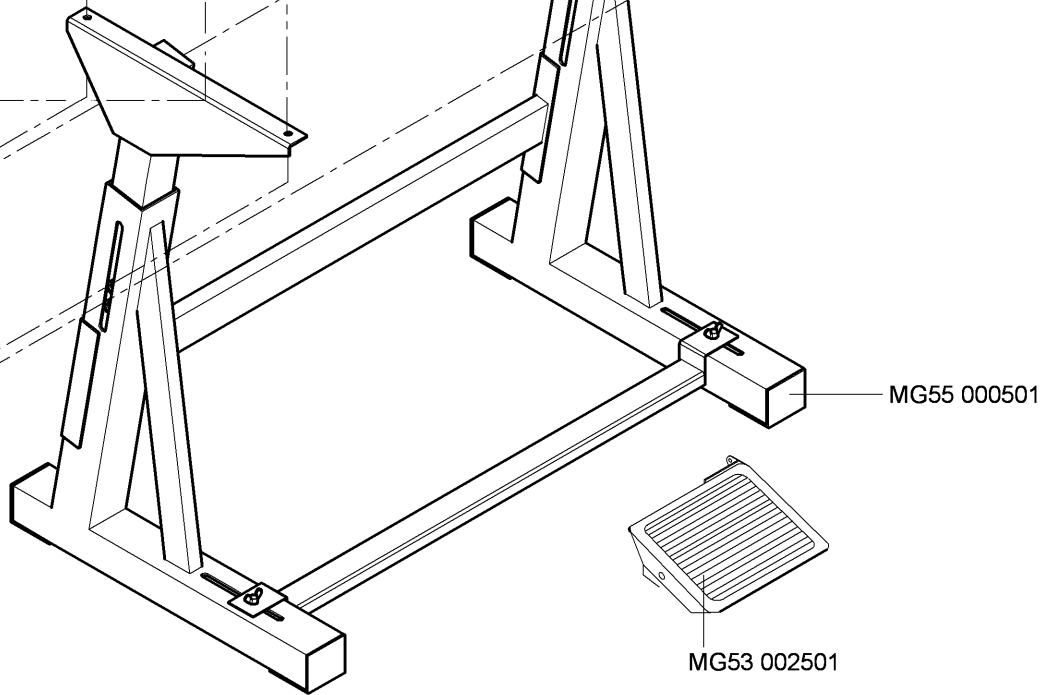
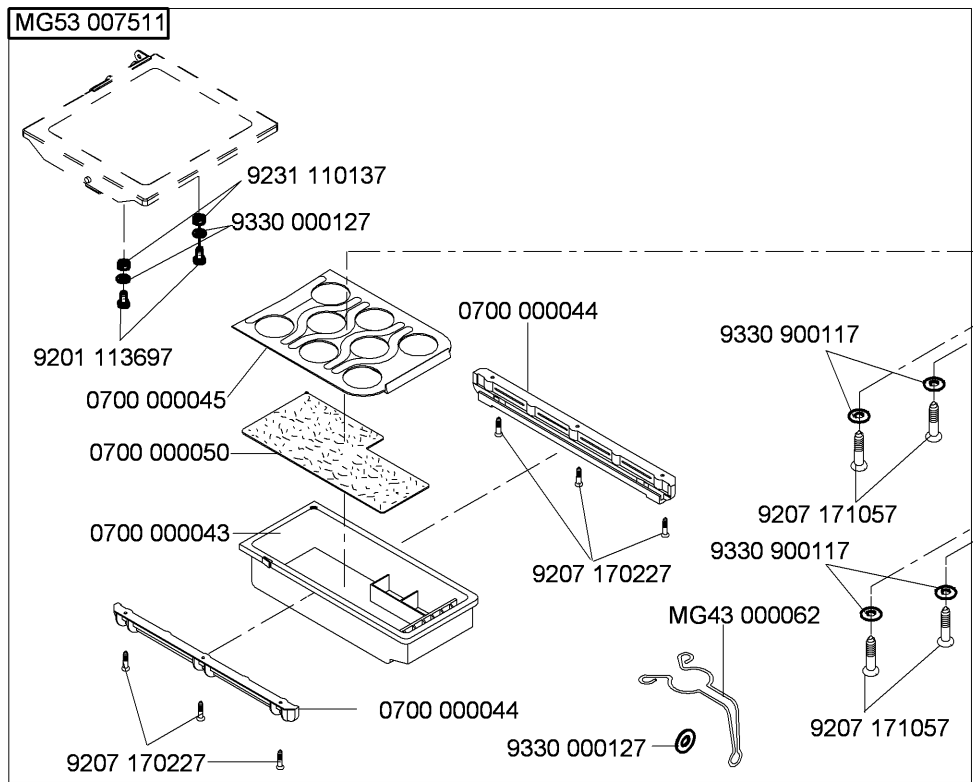
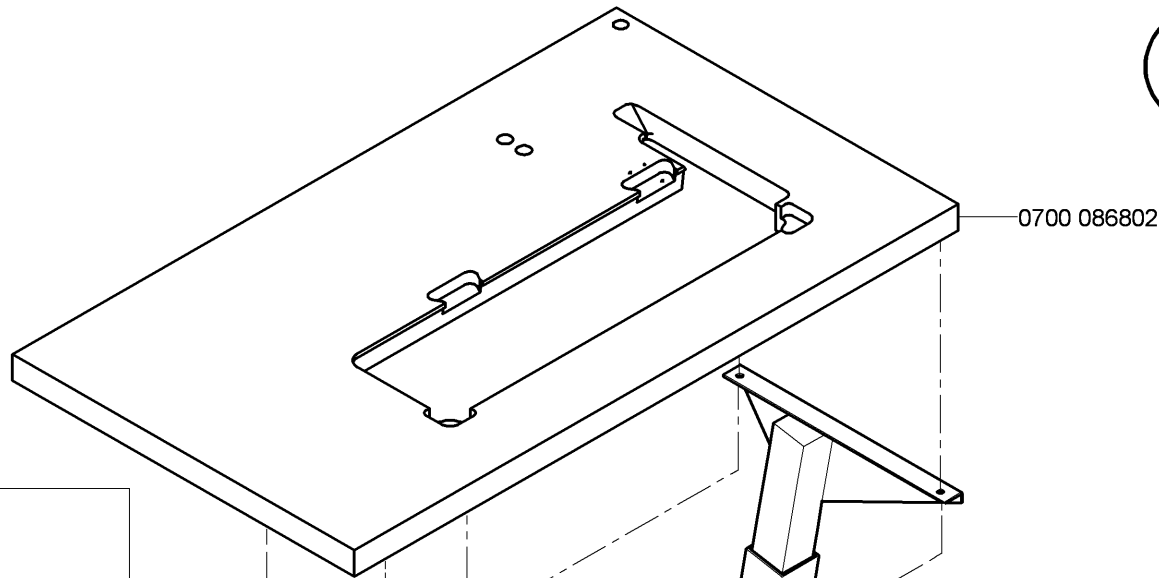

auf Wunsch
on request

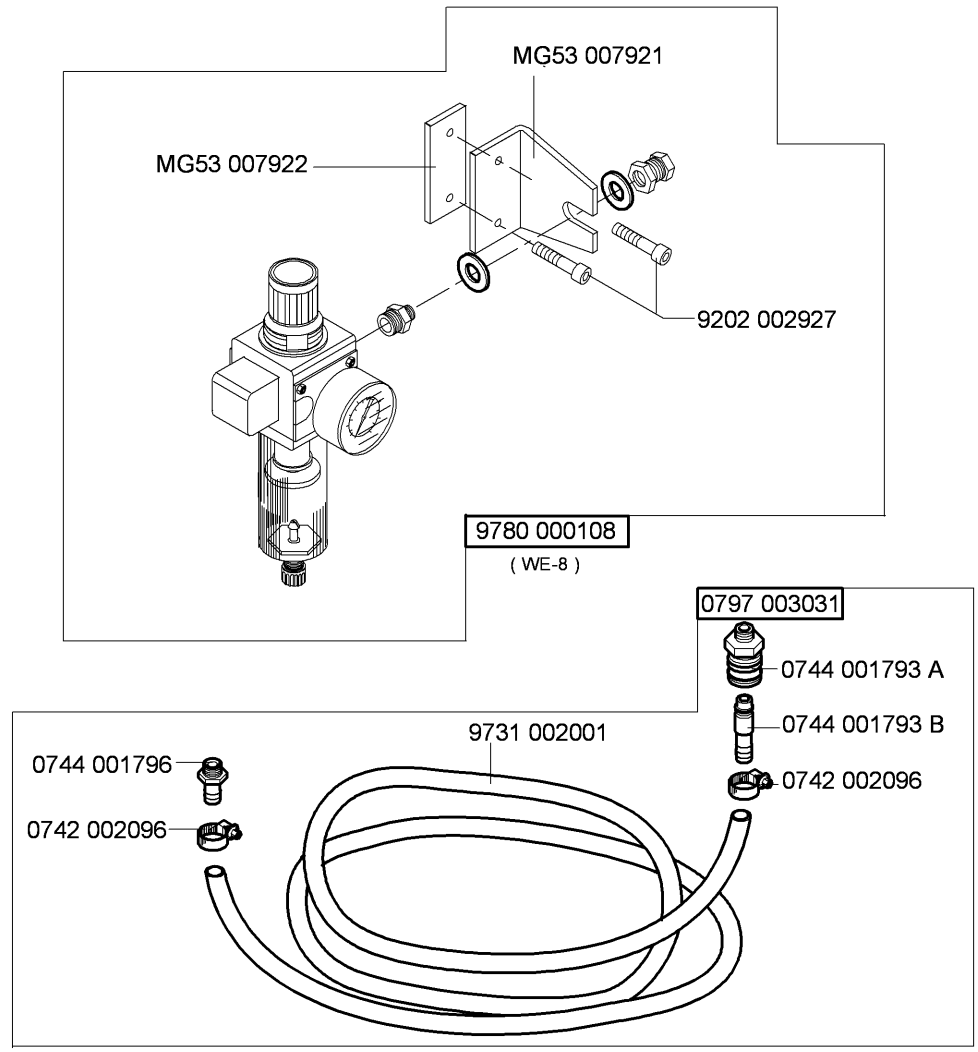

0791 001096

0077 110230

0791 580100

0396 111320

0791 001094

0911 000514

0791 001081

0995 340617

9330 000177

0995 340617

0281 380114

9081 500010

9081 200253

9081 200810

9081 200303

9081 100203

9081 500000

0367 105950

0688 100200

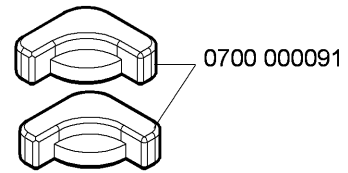

0700 000091

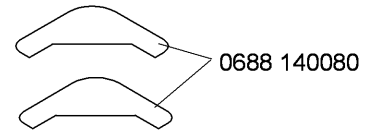

0688 140080

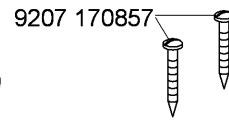

9207 170857

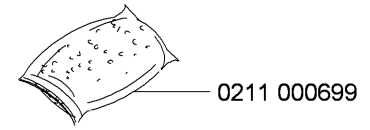

0211 000699

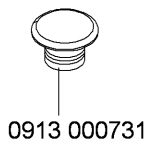

0913 000731

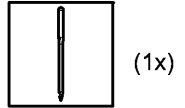

(1x)

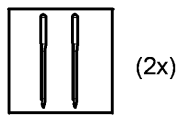

(2x)

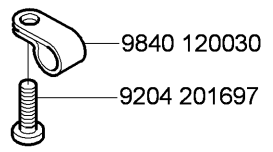

9840 120030

9204 201697

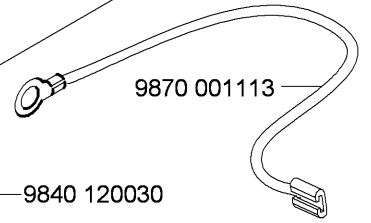

9870 001113

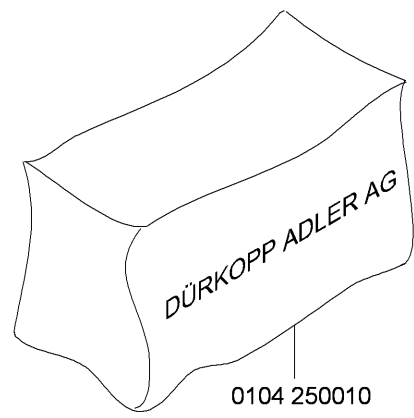

0104 250010

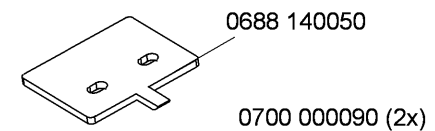

0688 140050

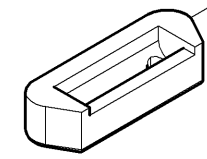

0700 000090 (2x)



9207 161237 (4x)

9850 001089

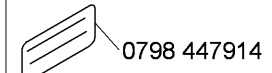

0798 447914

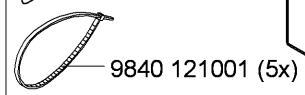

9840 121001 (5x)

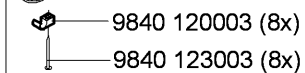

9840 120003 (8x)

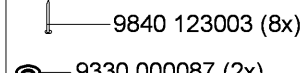

9840 123003 (8x)

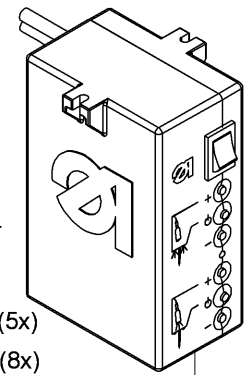

9850 001083

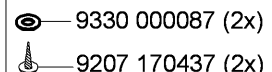

9330 000087 (2x)

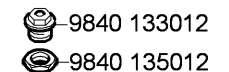

9840 133012

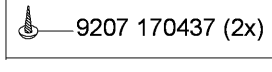

9207 170437 (2x)

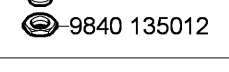

9840 135012

N - nicht als Einzelteil lieferbar
not available as separate part

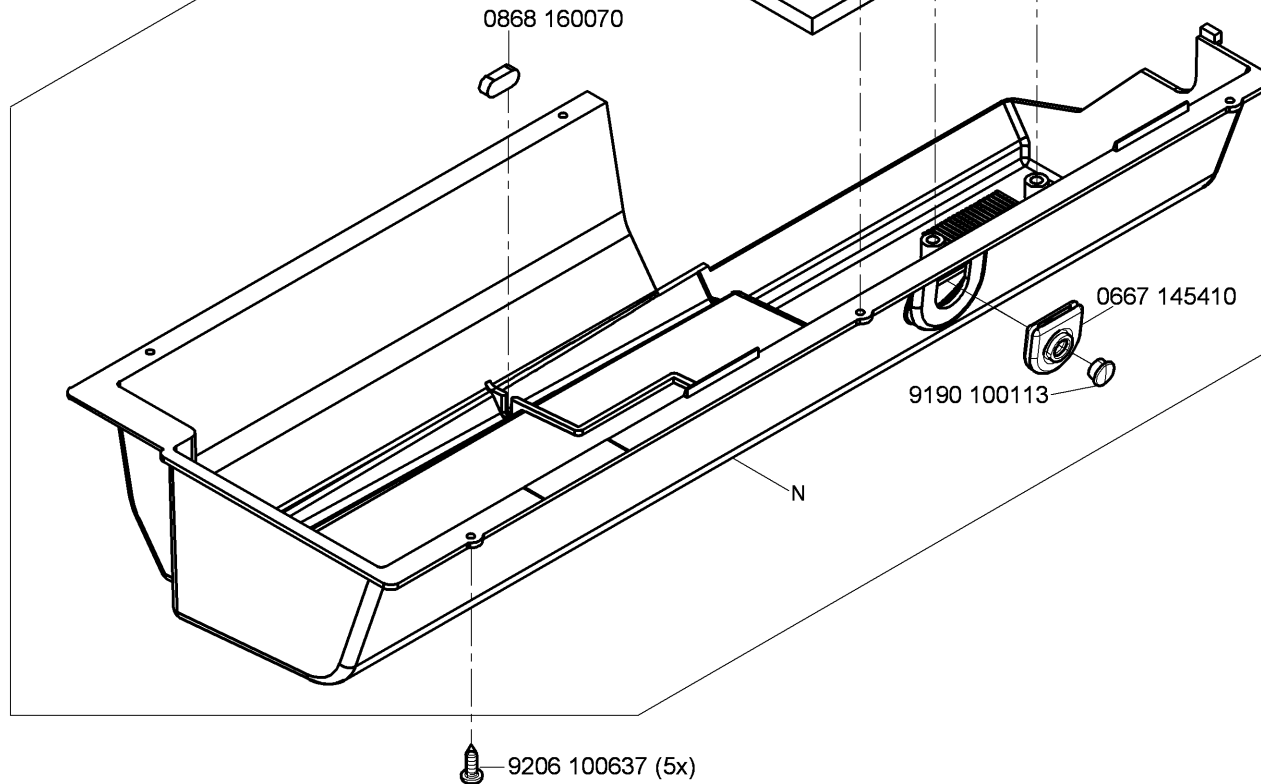
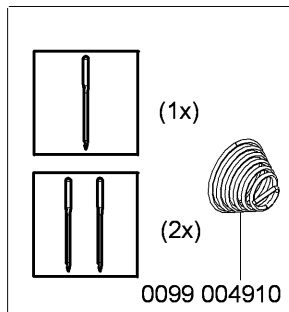
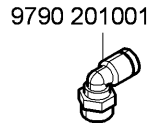
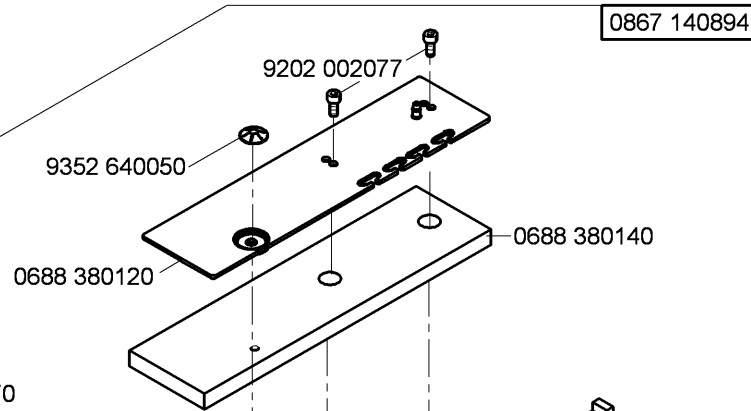
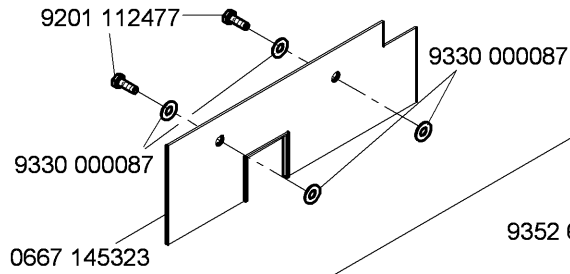
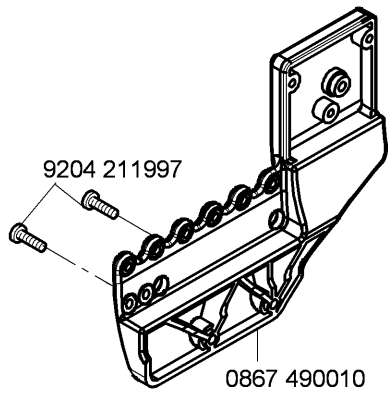

N - nicht als Einzelteil lieferbar
not available as separate part

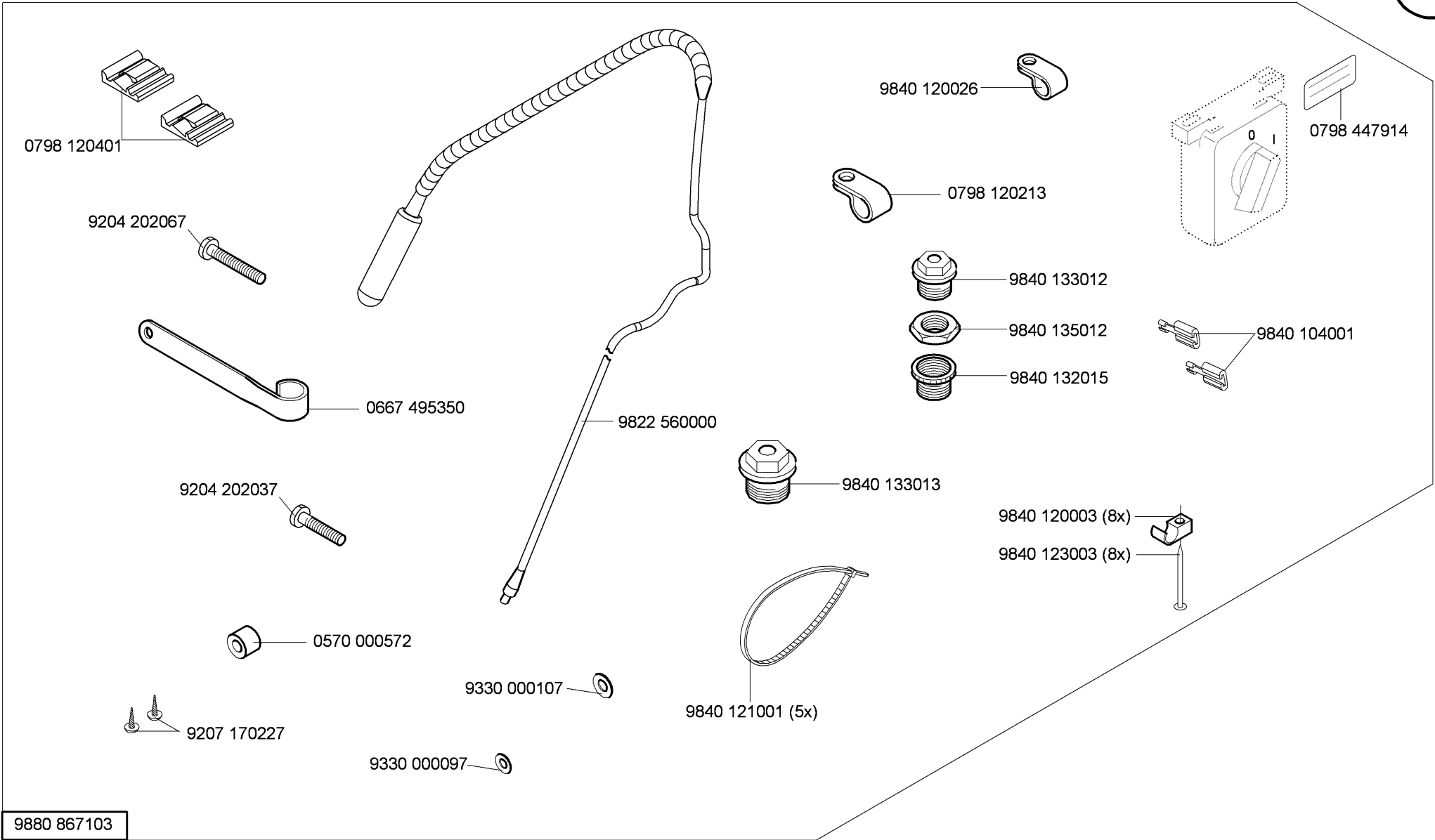

9880 867103

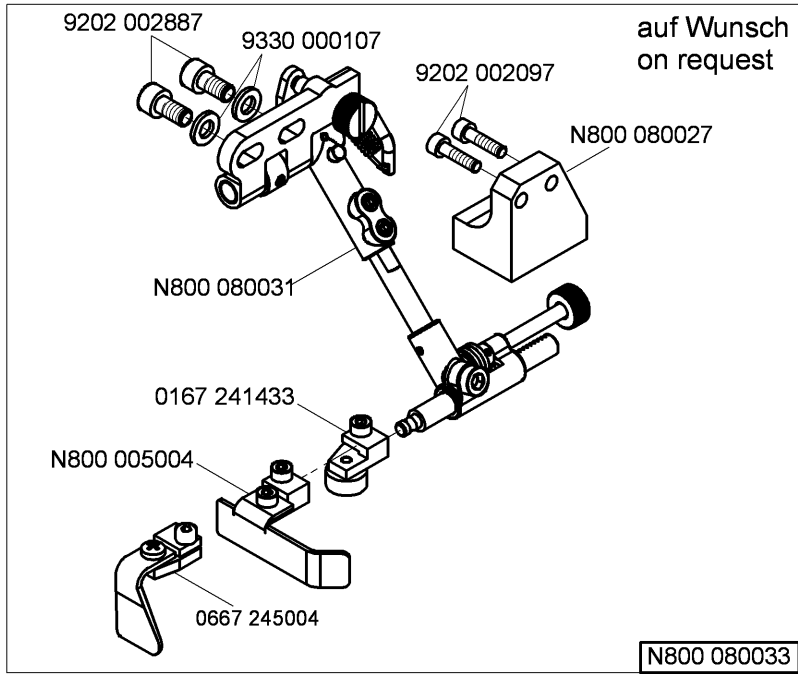

siehe Näherichtungen Blatt 1
see sewing equipment page 1
0867 590064

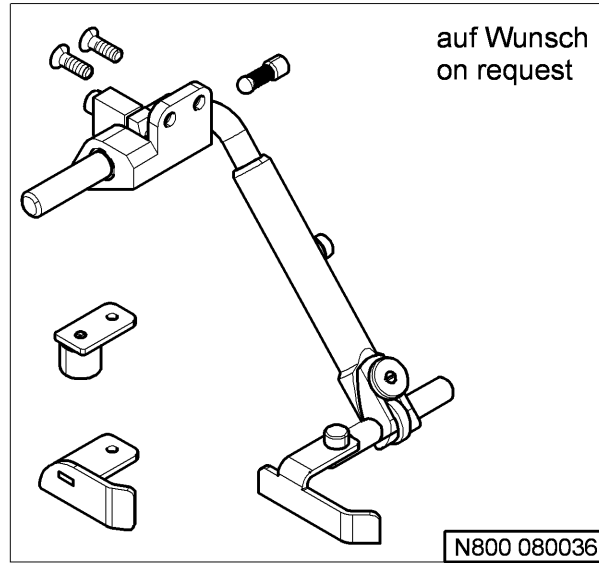
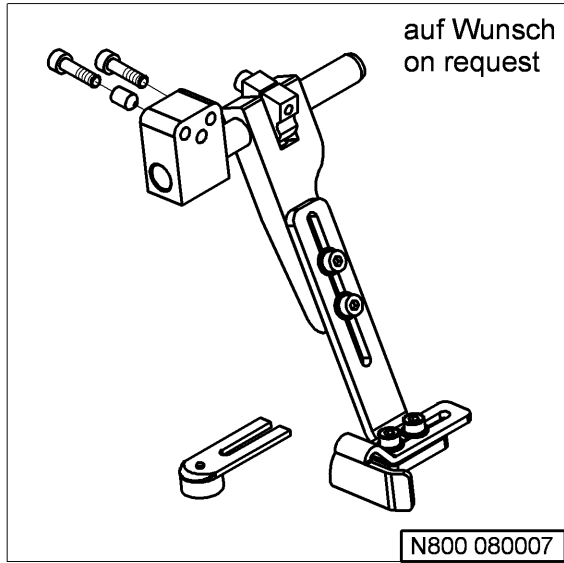
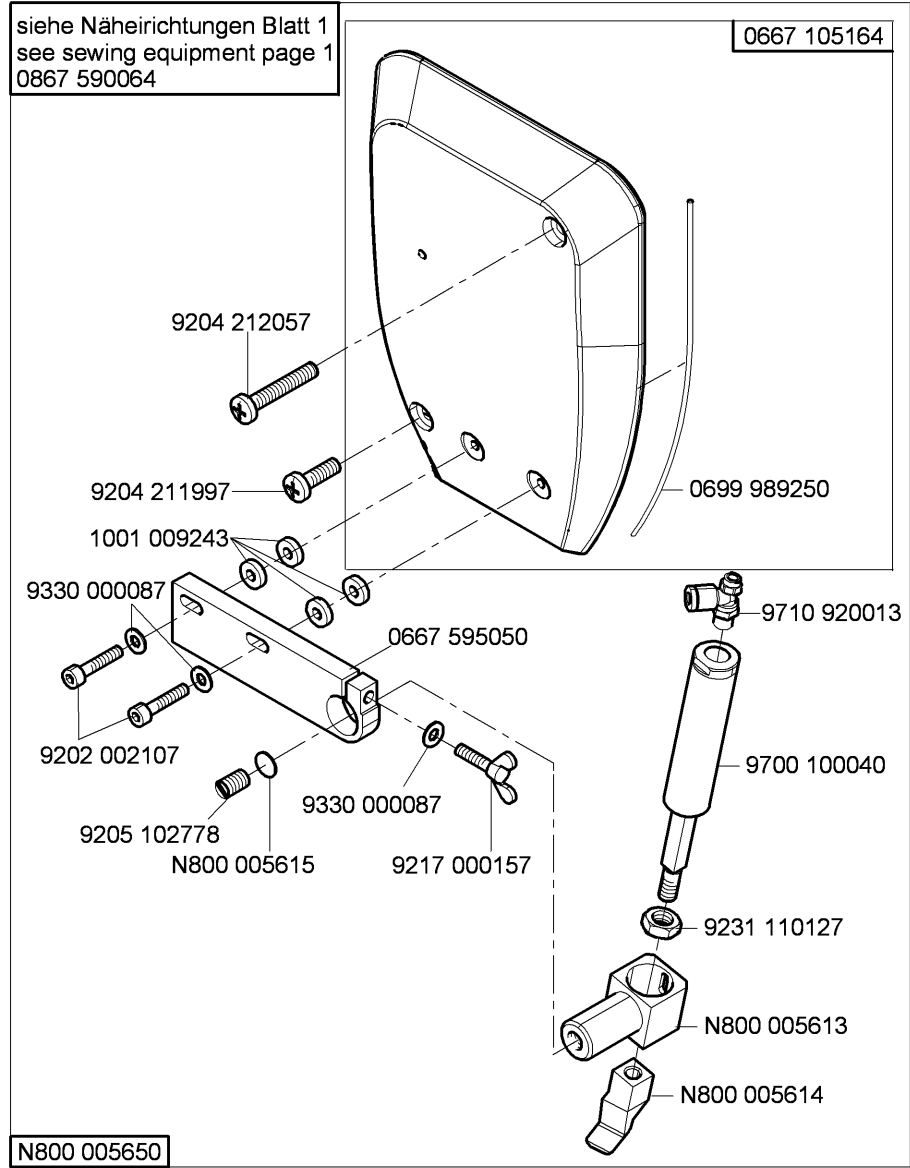

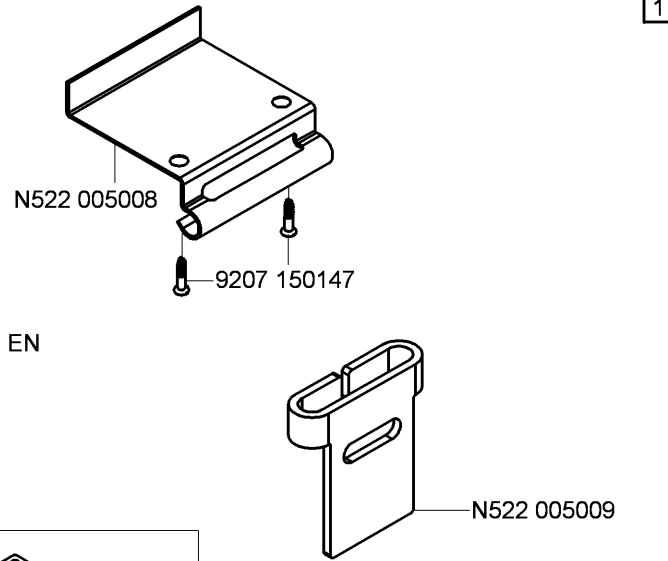
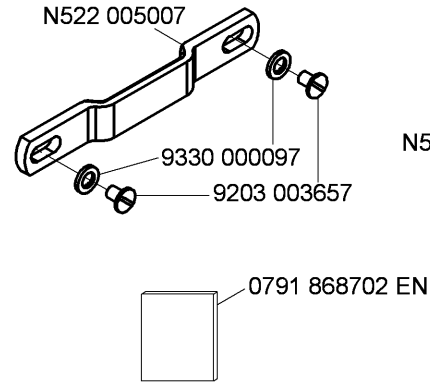
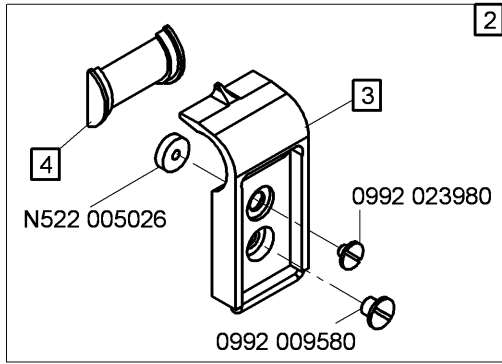

N900 001527

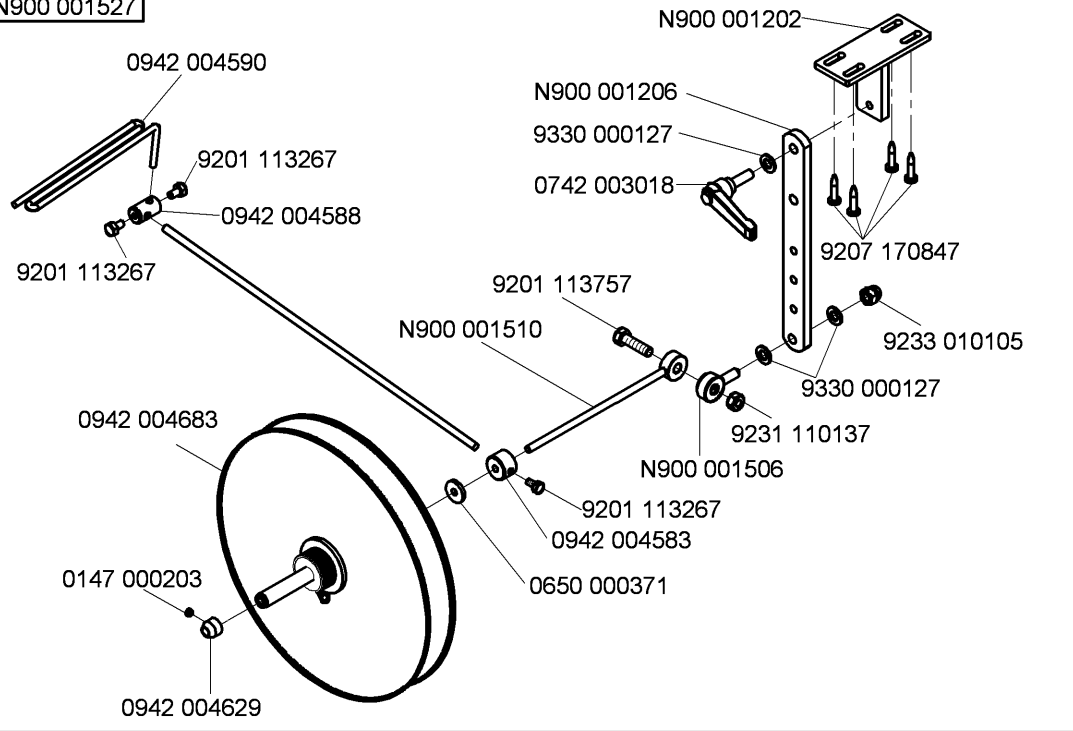

Pos.	Teile-Nr. / Part no.	NA / needle distance	Bandbreite / belt width
1	N522 025021	8	14
1	N522 025031	10	16
1	N522 025041	12	18
1	N522 025051	14	20
2	N522 025022	8	14
2	N522 025032	10	16
2	N522 025042	12	18
2	N522 025052	14	20
3	N522 025024	8	14
3	N522 025034	10	16
3	N522 025044	12	18
3	N522 025054	14	20
4	N522 025025	8	14
4	N522 025035	10	16
4	N522 025045	12	18
4	N522 025055	14	20

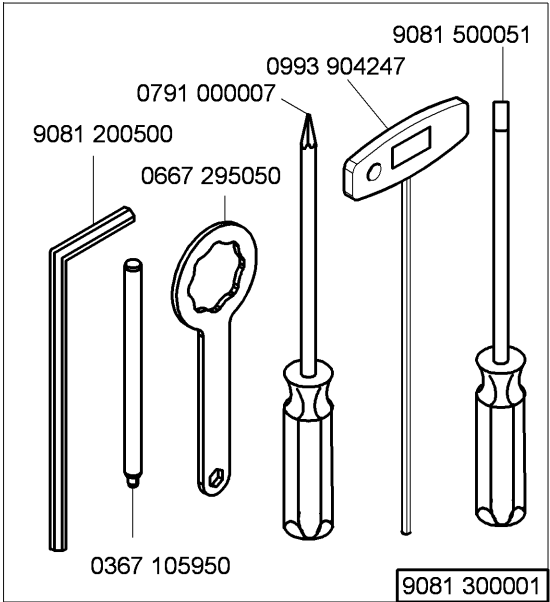
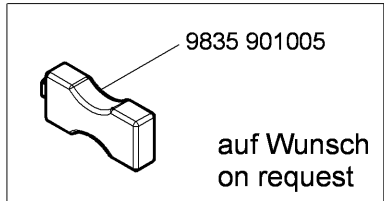

N - nicht als Einzelteil lieferbar
not available as separate part

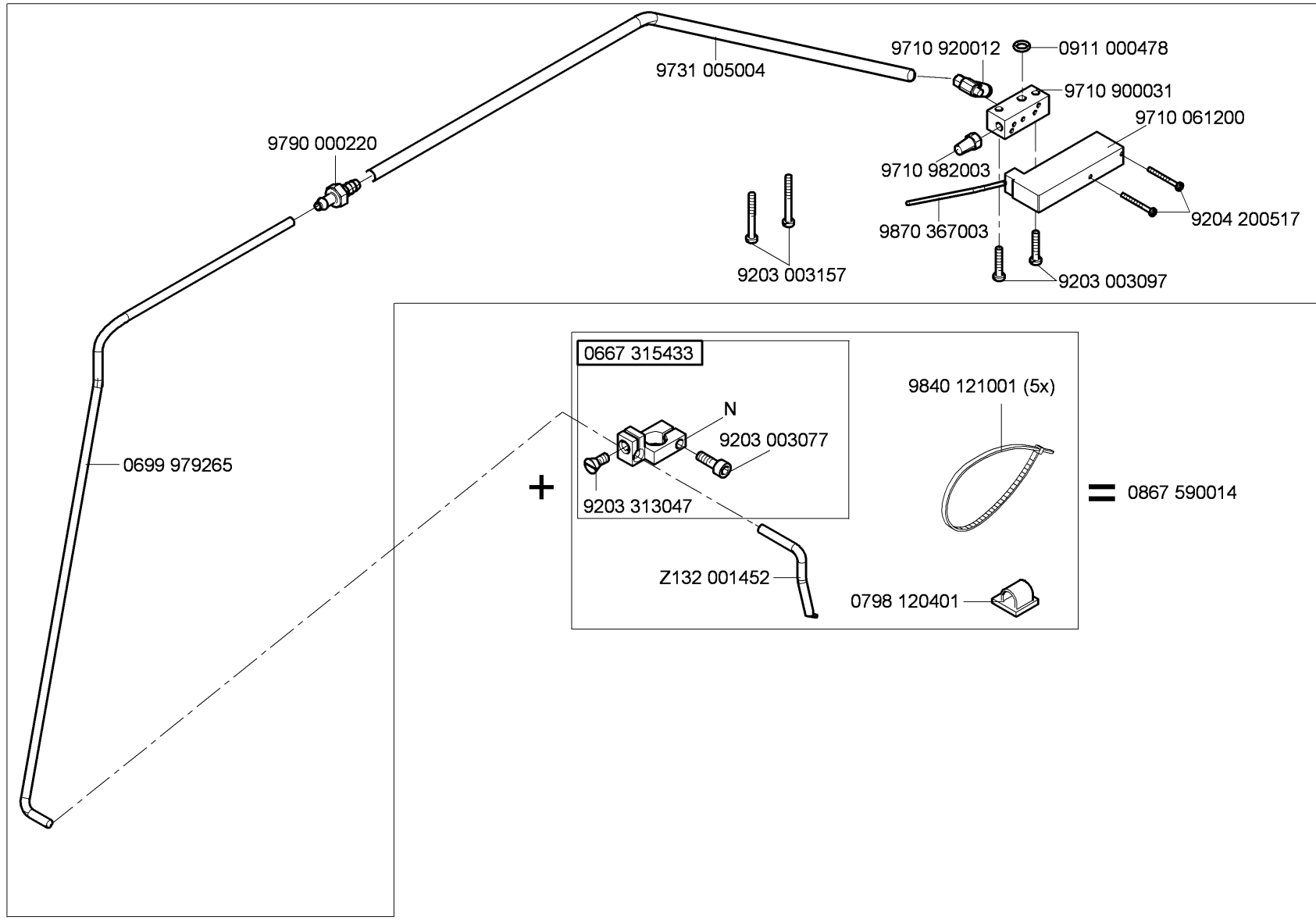

N - nicht als Einzelteil lieferbar
not available as separate part

Teile-Nr./Part-No.	Tafel/Table	Teile-Nr./Part-No.	Tafel/Table	Teile-Nr./Part-No.	Tafel/Table	Teile-Nr./Part-No.	Tafel/Table	Teile-Nr./Part-No.	Tafel/Table
0002 007504 9500	26	0367 135200	9	0667 115210	17,18	0667 145303	2	0667 165580	6
0037 001280	17,18	0367 145110	8	0667 115220	18	0667 145323	31	0667 170120	16
0061 001050	17,18	0367 145180	5,6,7	0667 115224	18	0667 145410	31	0667 175030	16
0077 110230	30	0367 150860	22	0667 115250	17,18	0667 145464	2	0667 175034	16
0099 004800	17,18	0367 165120	5,6	0667 115280	23	0667 150850	12	0667 175040	16
0099 004910	31	0367 165140	6	0667 115290	17,18	0667 155424	13,14	0667 175060	16
0104 250010	30	0367 165970	10	0667 115310	17,18	0667 155440	13	0667 245004	33
0147 000203	34	0367 315014	5	0667 115320	3	0667 155450	14	0667 295050	35
0167 241433	33	0367 315024	5	0667 115354	17,18	0667 155720	14	0667 315164	5
0211 000007	13,14	0367 315130	5	0667 115440	17	0667 155940	2	0667 315174	10
0211 000699	30	0367 315223	5,6,7,8	0667 115444	17	0667 155950	13	0667 315273	5
0216 000591	16	0367 385133	3	0667 115520	17,18	0667 156320	12	0667 315280	5
0219 000321	23	0367 495010	23	0667 115530	17,18	0667 160170	19	0667 315294	5
0244 000403	16	0396 111320	30	0667 115570	18	0667 160350	19	0667 315300	24
0244 000700	5,6,7,8,13,14	0467 110220	17,18	0667 115580	18	0667 160480	5	0667 315320	5
0271 000275	16	0491 030652	6	0667 115590	17,18	0667 165130	5	0667 315330	5
0271 001639	19	0556 000821 A	19	0667 115600	17	0667 165190	20	0667 315354	24
0281 380114	30	0570 000572	32	0667 115610	17,18	0667 165210	20	0667 315364	24
0291 000334	19	0570 001847	21	0667 115620	17	0667 165220	20	0667 315433	36
0291 000347	23	0650 000371	34	0667 115630	17,18	0667 165243	19	0667 355240	21
0291 000537	22	0667 100050	3	0667 115640	17,18	0667 165250	19	0667 385013	5,6
0291 000538	22	0667 105023	24	0667 125160	3	0667 165284	19	0667 385033	22
0327 310020	5	0667 105024	24	0667 125243	3	0667 165290	19	0667 385070	14
0367 100190	22	0667 105040	1	0667 135033	8	0667 165304	19	0667 385143	22
0367 105083	5,6,7	0667 105060	23	0667 135094	8	0667 165354	19	0667 385220	22
0367 105180	5,6,7	0667 105080	2	0667 135103	8	0667 165390	7	0667 495093	21
0367 105910	26	0667 105164	33	0667 135124	8	0667 165403	7	0667 495104	19
0367 105950	30,35	0667 105280	27	0667 135190	5	0667 165423	7	0667 495110	19
0367 110340	17,18	0667 110340	23	0667 135300	5	0667 165464	20	0667 495133	21
0367 110360	17,18	0667 115170	17,18	0667 145044	2	0667 165500	7	0667 495290	21
0367 120100	3	0667 115180	17	0667 145074	2	0667 165550	6	0667 495350	32
0367 125020	5	0667 115203	17,18	0667 145264	2	0667 165570	20	0667 595050	33

Teile-Nr./Part-No.	Tafel/Table	Teile-Nr./Part-No.	Tafel/Table	Teile-Nr./Part-No.	Tafel/Table	Teile-Nr./Part-No.	Tafel/Table	Teile-Nr./Part-No.	Tafel/Table
0688 100190	27	0791 001094	30	0867 142803	27	0867 490250	23	0868 160023	6
0688 100200	30	0791 001096	30	0867 142814	27	0867 490400	21	0868 160034	6
0688 130280	8	0791 580100	30	0867 142820	27	0868 100050	27	0868 160054	6
0688 130290	8	0791 868702 EN	34	0867 150190	12	0867 590014	36	0868 160064	19
0688 140020	25	0797 003031	29	0867 152084	12	0868 100110	27	0868 160070	11
0688 140050	30	0798 000677	27	0867 152094	12	0868 100120	27	0868 160070	11
0688 140060	27	0798 120213	32	0867 152100	12	0868 102144	27	0868 160070	31
0688 140080	30	0798 120401	32,36	0867 152120	12	0868 110054	18	0868 160080	6
0688 150024	2	0798 447914	26,30,32	0867 152130	12	0868 120200	4	0868 160120	19
0688 150290	13,14	0798 500088	26	0867 160203	7	0868 130144	9	0868 160144	7
0688 380040	22	0818 160010	11	0867 160274	6	0868 140040	11	0868 160200	11
0688 380120	31	0818 160024	11	0867 160620	5,6	0868 140060	25	0868 160223	11
0688 380130	22	0818 160040	11	0867 160630	5,6	0868 140170	13,14	0868 160303	19
0688 380140	31	0818 160210	6	0867 160640	5	0868 140323	15	0868 310013	4
0699 979104	13,14,22	0867 102633	1	0867 172050	16	0868 150010	13,14	0868 310023	4
0699 979265	36	0867 102640	23	0867 172060	16	0868 150083	13,14	0868 310033	4
0699 989250	23,24,33	0867 102650	23	0867 172083	16	0868 150120	13,14	0868 310203	4
0700 000043	28	0867 102700	23	0867 172094	16	0868 150160	13,14	0868 310223	4
0700 000044	28	0867 102730	3	0867 172103	16	0868 150170	13,14	0868 320030	11
0700 000045	28	0867 103303	2	0867 172110	16	0868 150220	13,14	0868 320040	11
0700 000050	28	0867 110250	17	0867 172120	16	0868 150240	13,14	0868 320050	11
0700 000090	30	0867 110260	18	0867 310430	5	0868 150250	13,14	0868 320070	11
0700 000091	30	0867 110564	17,18	0867 310440	5	0868 150260	13,14	0868 320104	11
0700 086802	28	0867 110570	17,18	0867 312013	4	0868 150283	13	0868 320114	11
0742 002096	29	0867 120294	23	0867 312120	4	0868 150293	14	0868 380024	22
0742 003018	34	0867 120760	3	0867 312130	4	0868 150310	13,14	0868 380100	22
0744 001155	17,18	0867 122204	3	0867 312143	4	0868 150320	13,14	0887 380010	22
0744 001793 A	29	0867 122233	3	0867 312253	5	0868 150330	13,14	0888 150163	13,14
0744 001793 B	29	0867 122280	3	0867 312283	5	0868 150340	13,14	0911 000478	21,36
0744 001796	29	0867 130023	8	0867 312303	5	0868 150713	2	0911 000514	30
0791 000007	35	0867 132360	5	0867 312324	5	0868 150720	15	0911 150120	12
0791 001081	30	0867 140894	31	0867 490010	31	0868 160014	6	0913 000731	30

Teile-Nr./Part-No.	Tafel/Table	Teile-Nr./Part-No.	Tafel/Table	Teile-Nr./Part-No.	Tafel/Table	Teile-Nr./Part-No.	Tafel/Table	Teile-Nr./Part-No.	Tafel/Table
0933 001544	22	9081 500010	30	9202 002387	23	9204 201957	27	9207 171057	28
0942 004583	34	9081 500051	35	9202 002497	11,27	9204 201967	27	9217 000157	33
0942 004588	34	9122 200161	1	9202 002887	33	9204 202037	23,32	9225 201750	3
0942 004590	34	9126 102520	5,6,19	9202 002888	19	9204 202067	32	9225 201770	17,18,23,26
0942 004629	34	9126 102540	5,6,19	9202 002907	8,27	9204 211997	2,5,6,19,23,24,27, 31,33	9230 000067	2
0942 004683	34	9126 300089	13,14	9202 002908	13,14	9204 212057	27,33	9231 000387	8
0992 001020	22	9130 221330	2	9202 002918	5	9204 301467	21,23	9231 110037	16,21
0992 009580	34	9130 221340	27	9202 002927	29	9204 301487	16	9231 110057	25
0992 016580	12	9190 100108	23	9202 002947	3	9204 302217	10,19,20	9231 110127	33
0992 023560	12	9190 100113	31	9202 003808	23	9204 431657	11,13,14,17,18	9231 110137	28,34
0992 023577	12	9190 100155	24	9202 022467	22	9205 101528	13,14	9233 010105	34
0992 023980	34	9190 100226	13,14	9202 042067	13,14	9205 101847	25	9234 000067	19
0993 904247	35	9199 000004	21	9202 100535	2,14	9205 102303	5	9301 101551	13,14
0995 340617	30	9201 112477	31	9203 001867	19	9205 102450	11,13,14	9301 102203	5
0998 881610	5,20	9201 113267	34	9203 003077	36	9205 102464	19	9301 200660	13,14
0998 881630	8	9201 113317	27	9203 003087	21	9205 102467	1,2,3,4,5,6,7,8,10, 13,14,16	9302 000100	22
0998 882080	4	9201 113697	28	9203 003097	36	9205 102468	5	9303 502990	27
0998 912110	3	9201 113757	34	9203 003157	36	9205 102477	2,7,11,12,19,27	9305 100350	17
0999 201114	25	9202 001637	13,14	9203 003657	34	9205 102487	2,5	9305 100370	18
0999 220752	22	9202 001657	13,14	9203 100002	17,18	9205 102778	33	9330 000027	19
1001 001162	23,25	9202 001678	3,16	9203 211837	12	9205 102787	2	9330 000047	13,14
1001 009243	6,33	9202 002057	5,6,22	9203 313047	36	9205 121558	13,14	9330 000067	13,14,17,18,21
9041 100015	5,13,14	9202 002058	7	9204 002077	22	9205 122488	13,14	9330 000087	3,4,13,14,17,18, 19,27,30,31,33
9041 100025	3,13,14	9202 002067	22	9204 002363	25	9206 100637	22,31	9330 000097	2,27,32,34
9041 100035	22	9202 002077	6,11,13,14,19,26, 27,31	9204 101657	5	9207 150147	34	9330 000107	27,32,33
9041 100203	22,30	9202 002078	3	9204 200447	21	9207 161237	30	9330 000127	28,34
9081 200253	30	9202 002087	20,22,23	9204 200517	21,36	9207 170227	27,28,32	9330 000177	30
9081 200303	30	9202 002088	19	9204 201067	16,19,21	9207 170437	26,27,30	9330 200110	13,14
9081 200500	35	9202 002097	19,26,33	9204 201647	3,17,18,19,23,25	9207 170847	34	9330 700107	24
9081 200810	30	9202 002098	4,5,6,8,19,23	9204 201657	27	9207 170857	30	9330 900117	28
9081 300001	35	9202 002107	33	9204 201667	3,16,20,21,22			9333 000090	25
9081 500000	30			9204 201697	17,18,30				

Teile-Nr./Part-No.	Tafel/Table	Teile-Nr./Part-No.	Tafel/Table	Teile-Nr./Part-No.	Tafel/Table	Teile-Nr./Part-No.	Tafel/Table	Teile-Nr./Part-No.	Tafel/Table
9334 000051	13,14	9710 982003	36	9822 642027	26	9850 867001	22	N800 080007	33
9334 001630	3,5,6,16,19	9710 982006	21	9825 551102	21	9850 867018	23	N800 080027	33
9334 001640	4,7	9731 001035	13,14,22	9825 810302	26	9850 H66703	17,18	N800 080031	33
9334 002190	4	9731 002001	29	9830 501010	21	9870 001112	10	N800 080033	33
9350 000087	22	9731 005004	9,10,18,19,20,21,	9830 502014	22	9870 001113	30	N800 080036	33
9352 000080	13,14		36	9835 901005	35	9870 367003	36	N900 001202	34
9352 640050	31	9740 000607	24	9840 104001	26,32	9870 867000	27	N900 001206	34
9353 000350	2	9742 300190	10	9840 120003	10,26,27,30,32	9870 867002	19	N900 001506	34
9353 000420	2	9742 300200	9	9840 120025	10,13,14	9880 001005	27	N900 001510	34
9353 000470	1,2	9780 000108	29	9840 120026	19,22,26,32	9880 002005	10	N900 001527	34
9354 010190	27	9790 000220	36	9840 120028	22	9880 867100	26	Z132 001452	36
9354 010210	2	9790 000490	22	9840 120029	13,14,22	9880 867101	21		
9354 400800	13,14,22	9790 020010	18	9840 120030	30	9880 867103	32		
9357 000070	5,6,9,10,16,19	9790 200000	21	9840 120060	27	9880 867105	10		
9357 000080	7	9790 201000	21	9840 120104	21,22,25	9880 867118	23		
9357 000090	4,5	9790 201001	31	9840 120105	20,22	9880 867120	10		
9357 000100	19	9800 170040	27	9840 121001	10,17,18,22,26,	H667 110050	17,18		
9357 000120	4,5,6,19,20	9800 210001 R	27		30,32,36	MG43 000062	28		
9400 000088	13,14	9800 327007	27	9840 123002	27	MG53 002501	28		
9400 000227	11	9815 301079	21	9840 123003	10,26,30,32	MG53 007511	28		
9401 000194	27	9815 301081	21	9840 130007	22	MG53 007921	29		
9401 000204	27	9815 301090	21	9840 130008	22	MG53 007922	29		
9700 100040	33	9815 301091	21	9840 132015	26,32	MG55 000501	28		
9700 100094	10	9815 301096	21	9840 133012	26,30,32	N522 005007	34		
9700 100100	19,20	9815 301114	21	9840 133013	26,32	N522 005008	34		
9700 102390	9	9815 310008	21	9840 135012	26,30,32	N522 005009	34		
9710 061200	21,36	9815 310009	21	9850 001083	30	N522 005026	34		
9710 900011	21	9815 310030	30	9850 001089	30	N800 005004	33		
9710 900031	36	9822 510003	26	9850 001309	27	N800 005613	33		
9710 900047	21	9822 510013	26	9850 001311	27	N800 005614	33		
9710 920012	21,36	9822 560000	32	9850 001340	27	N800 005615	33		
9710 920013	33	9822 610000	26	9850 867000	21	N800 005650	33		



E201/0/12
E207/0/12

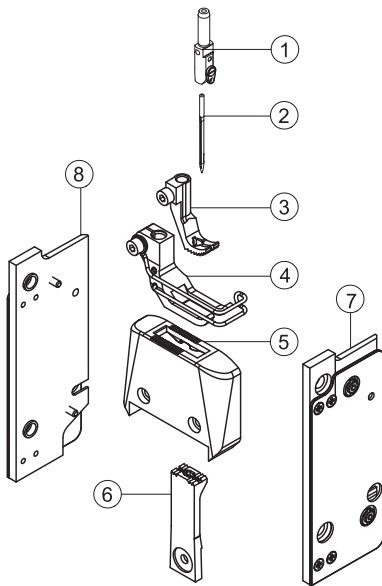

0867 232134 - auf Wunsch/on request
für Nadeln mit dem Kolbendurchmesser 2 mm/
for needles with shank diameter 2 mm

E231/8/12 E237/8/12
E231/10/12 E237/10/12
E231/12/12 E237/12/12

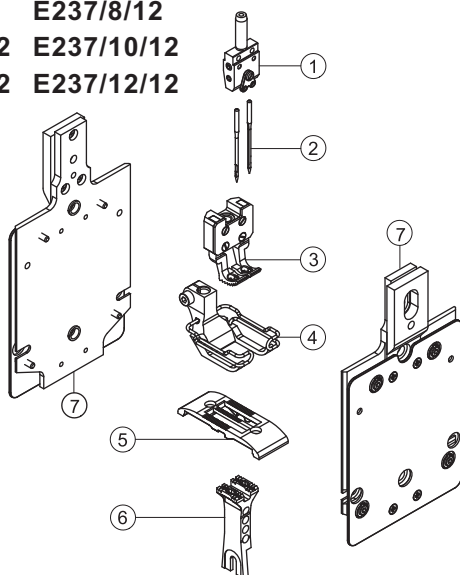

E231/14/12 E237/14/12
E231/16/12 E237/16/12

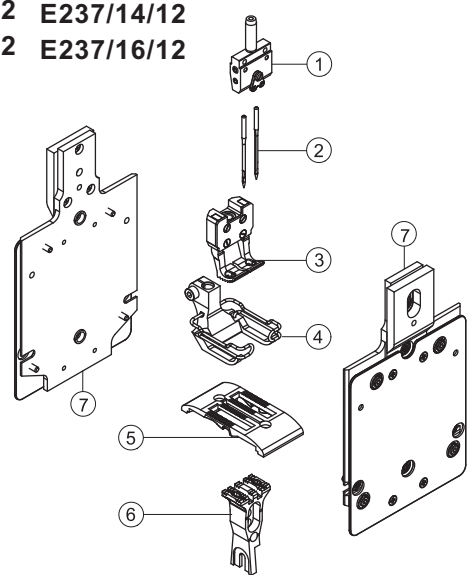



E-Nr. E-No.	Für Unterklasse / For Subclass	Abb.-Nr. Fig.No.	Verwendungszweck / Use	Material No. / Material Nr.	Stichplatte Throat plate			Transporteur Feed dog ⑥			Presserfuß Presser foot ④			Transp. Fuß Feeding foot ③					
					Stichplatte / Throat plate ⑤	Schieber, links / Slide, left	Schieber, rechts / Slide, right	Stichlochgröße / Stitch hole size mm	Sägeverzahn / Serrated mm	Säge-schrägverzahn / Serrated, oblique mm	Kreuzverzahn / Cross toothed mm	Drückerfuß / Presser foot	Unverzahn / Non toothed	Hüpfersfuß, kreuzverz. / Skipping f., cross toothed	Ausgleichfuß / Compensating foot	Sägeverzahn / Serrated	Unverzahn / Non toothed	Seitenblech/Lateral cover ⑧	Seitenblech/Lateral cover ⑦
E201/0/12	-190361 Näheinrichtung, Nadelstärke Nm 140-180, Stichlänge max. 12 mm, für mittelschweres Nähgut. Sewing equipment, needle size Nm 140-180, stitch length max. 12 mm, for medium weight material.			H868 E20112	0868 200300			∅ 3	0868 210010			0768 220013			0768 220113	0868 140274	0868 140264	0867 232404	7x23/180
E207/0/12	-190361 Näheinrichtung, Nadelstärke Nm 180-230, Stichlänge max. 12 mm, für schweres Nähgut. Sewing equipment, needle size Nm 180-230, stitch length max. 12 mm, for weight material.			H868 E20712	0868 200310			3,2 x 5,0	0868 210100			0768 220013			0867 222203	0868 140274	0868 140264	0867 232404	7x23/180



E-Nr. E-No.	Für Unterklasse / For Subclass	Abb.-Nr. Fig.No.	Verwendungszweck / Use	Material No. / Material Nr.	Stichplatte Throat plate			Transporteur Feed dog ⑥			Presserfuß Presser foot ④			Transp. Fuß Feeding foot ③						
					Stichplatte / Throat plate ⑤	Schieber, links / Slide, left	Schieber, rechts / Slide, right	Stichlochgröße / Stitch hole size mm	Sägeverzahnung / Serrated mm	Säge-schrägverzahnung / Serrated, oblique mm	Kreuzverzahnung / Cross toothed mm	Drückerfuß / Presser foot	Unverzahnung / Non toothed	Hüpfersfuß, kreuzverz. / Skipping f., cross toothed	Ausgleichfuß / Compensating foot	Kreuzverzahnung / Cross toothed mm	Unverzahnung / Non toothed	Nadelabstand / Needle distance	Seitenblech / Lateral cover	Nadelhalter / Needle holder
E231/8/12	-290361 Näheinrichtung, Nadelabstand 8 mm, Nadelstärke Nm 140-180, Stichtlänge max. 12 mm, für mittelschweres Nähgut. Sewing equipment, needle gauge 8 mm, needle size Nm 140-180, stitch length max. 12 mm, for medium weight material.			H868 E23112 8	0868 204250			Ø 3	0868 212250			0768 222133			0768 222374		8	0868 14528 4	0867 232384	7x23/180
E231/10/12	-290361 Näheinrichtung, Nadelabstand 10 mm, Nadelstärke Nm 140-180, Stichtlänge max. 12 mm, für mittelschweres Nähgut. Sewing equipment, needle gauge 10 mm, needle size Nm 140-180, stitch length max. 12 mm, for medium weight material.			H868 E23112 10	0868 204310			Ø 3	0868 212310			0768 222143			0768 222404		10	0868 145344	0867 232414	7x23/180
E231/12/12	-290361 Näheinrichtung, Nadelabstand 12 mm, Nadelstärke Nm 140-180, Stichtlänge max. 12 mm, für mittelschweres Nähgut. Sewing equipment, needle gauge 12 mm, needle size Nm 140-180, stitch length max. 12 mm, for medium weight material.			H868 E23112 12	0868 204370			Ø 3	0868 212370			0768 222153			0768 222434		12	0868 145404	0867 232424	7x23/180
E231/14/12	-290361 Näheinrichtung, Nadelabstand 14 mm, Nadelstärke Nm 140-180, Stichtlänge max. 12 mm, für mittelschweres Nähgut. Sewing equipment, needle gauge 14 mm, needle size Nm 140-180, stitch length max. 12 mm, for medium weight material.			H868 E23112 14	0868 204430			Ø 3	0868 212430			0768 222163			0768 2223464		14	0868 145464	0867 232434	7x23/180
E231/16/12	-290361 Näheinrichtung, Nadelabstand 16 mm, Nadelstärke Nm 140-180, Stichtlänge max. 12 mm, für mittelschweres Nähgut. Sewing equipment, needle gauge 16 mm, needle size Nm 140-180, stitch length max. 12 mm, for medium weight material.			H868 E23112 16	0868 204490			Ø 3	0868 212490			0868 222303			0868 222134		16	0868 145524	0867 232444	7x23/180



E-Nr. E-No.	Für Unterklasse / For Subclass	Abb.-Nr. Fig.No.	Verwendungszweck / Use	Material No. / Material Nr.	Stichplatte Throat plate			Transporteur Feed dog ⑥			Presserfuß Presser foot ④			Transp. Fuß Feeding foot ③						
					Stichplatte / Throat plate ⑤	Schieber, links / Slide, left	Schieber, rechts / Slide, right	Stichlochgröße / Stitch hole size mm	Sägeverzahn / Serrated mm	Säge-schrägverzahn / Serrated, oblique mm	Kreuzverzahn / Cross toothed mm	Drückerfuß / Presser foot	Unverzahn / Non toothed	Hüpfenfuß, kreuzverz. / Skipping f., cross toothed	Ausgleichfuß / Compensating foot	Kreuzverzahn / Cross toothed mm	Unverzahn / Non toothed	Nadelabstand / Needle distance	Seitenblech / Lateral cover ⑦	Nadelhalter / Needle holder ①
E237/8/12	-290361 Näheinrichtung, Nadelabstand 8 mm, Nadelstärke Nm 180-230, Stichlänge max. 12 mm, für schweres Nähgut. Sewing equipment, needle gauge 8 mm, needle size Nm 180-230, stitch length max. 12 mm, for weight material.			H868 E23712 8	0868 205250			3,2 x 5,0	0868 213250			0867 222253			0867 222244		8	0868 145254	0867 232384	7x23/180
E237/10/12	-290361 Näheinrichtung, Nadelabstand 10 mm, Nadelstärke Nm 180-230, Stichlänge max. 12 mm, für schweres Nähgut. Sewing equipment, needle gauge 10 mm, needle size Nm 180-230, stitch length max. 12 mm, for weight material.			H868 E23712 10	0868 205310			3,2 x 5,0	0868 213310			0867 222513			0867 222284		10	0868 145314	0867 232414	7x23/180
E237/12/12	-290361 Näheinrichtung, Nadelabstand 12 mm, Nadelstärke Nm 180-230, Stichlänge max. 12 mm, für schweres Nähgut. Sewing equipment, needle gauge 12 mm, needle size Nm 180-230, stitch length max. 12 mm, for weight material.			H868 E23712 12	0868 205370			3,2 x 5,0	0868 213370			0867 222523			0867 222324		12	0868 145374	0867 232424	7x23/180
E237/14/12	-290361 Näheinrichtung, Nadelabstand 14 mm, Nadelstärke Nm 180-230, Stichlänge max. 12 mm, für schweres Nähgut. Sewing equipment, needle gauge 14 mm, needle size Nm 180-230, stitch length max. 12 mm, for weight material.			H868 E23712 14	0868 205430			3,2 x 5,0	0868 213430			0867 222533			0867 222364		14	0868 145434	0867 232434	7x23/180
E237/16/12	-290361 Näheinrichtung, Nadelabstand 16 mm, Nadelstärke Nm 180-230, Stichlänge max. 12 mm, für schweres Nähgut. Sewing equipment, needle gauge 16 mm, needle size Nm 180-230, stitch length max. 12 mm, for weight material.			H868 E23712 16	0868 205490			3,2 x 5,0	0868 213490			0867 222543			0867 222404		16	0868 145494	0867 232444	7x23/180

Befestigungsteile für Nähmaschinen
Fastening parts for Sewing equipment

9202 002087

9202 002057

9202 001678

9202 001678

9205 101827

9205 101827

0291 000153

9205 101827

0292 006903

558 60a

9205 101827

558 60a

9205 023620

0768 222760

9203 001827

0244 000700

9203 003652

9205 101878

9203 312431

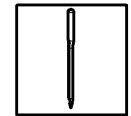

9202 002077

0818 160040



9400 000227

0818 160040

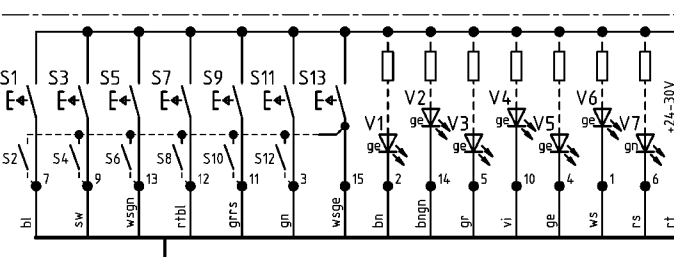
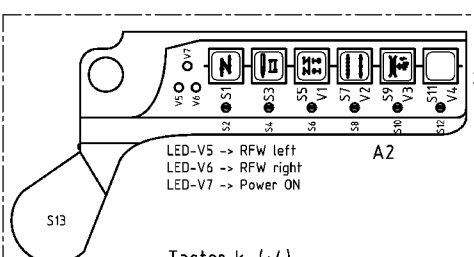
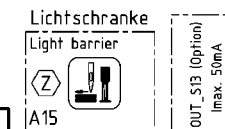
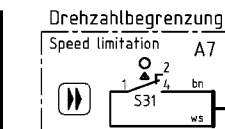
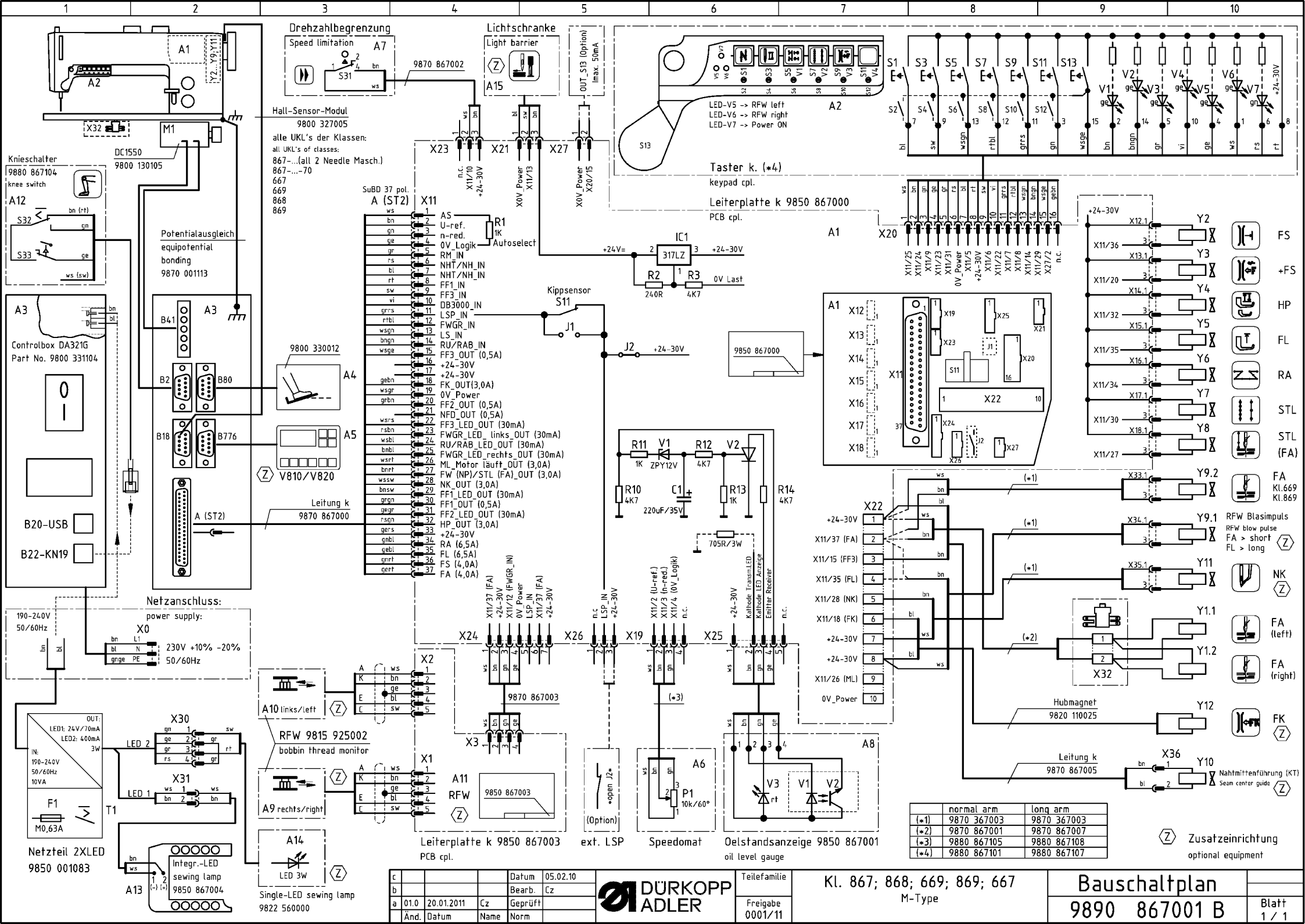

Hall-Sensor-Modul
9800 327005

alle UKL's der Klassen:
all UKL's of classes:
867... (all 2 Needle Masch.)
867.....70
667
669
868
869

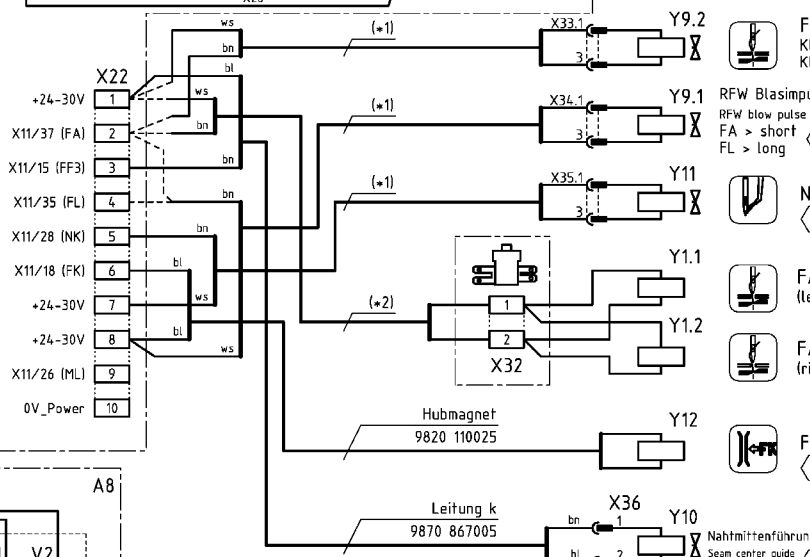
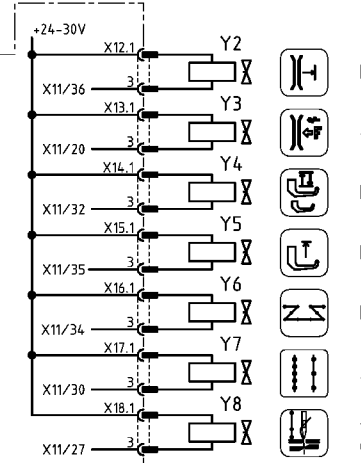
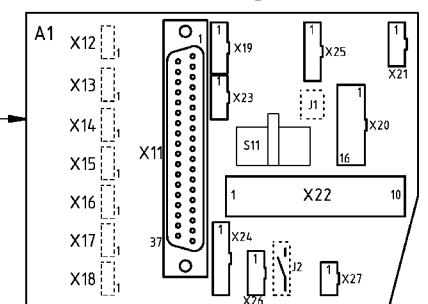
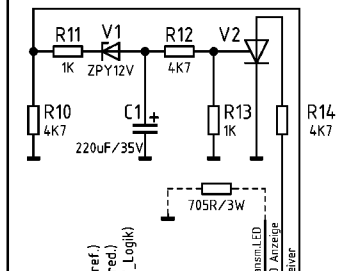
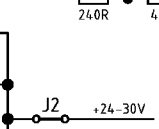
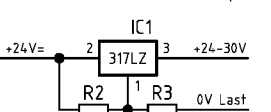
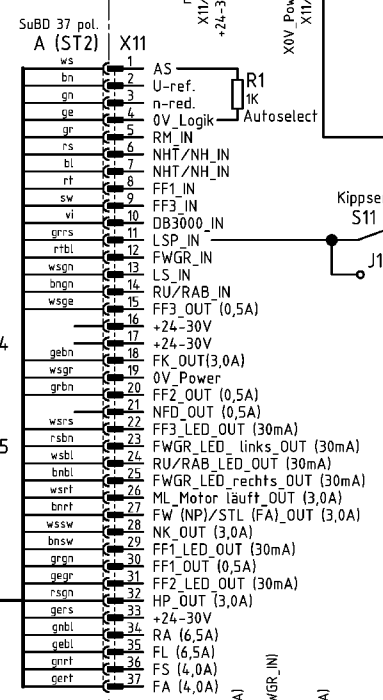

	normal arm	long arm
(*1)	9870 367003	9870 367003
(*2)	9870 867001	9870 867007
(*3)	9880 867105	9880 867108
(*4)	9880 867101	9880 867107

(Z) Zusatzeinrichtung
optional equipment

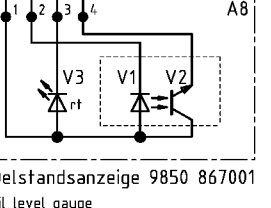
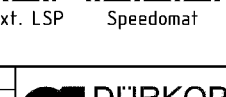
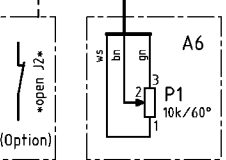
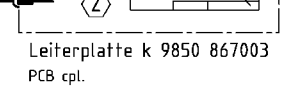
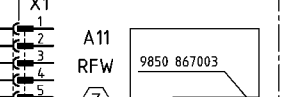
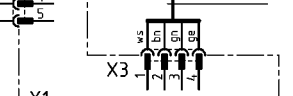
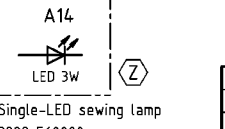
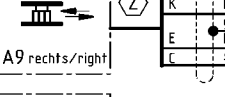
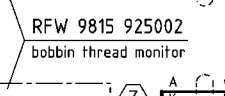
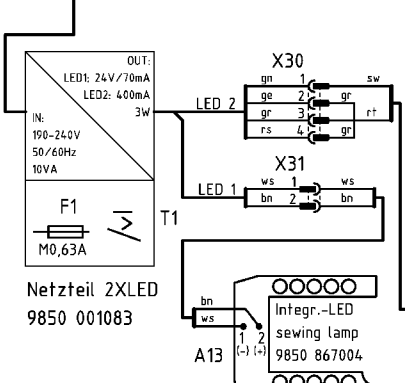
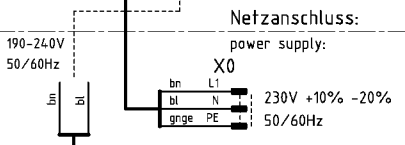
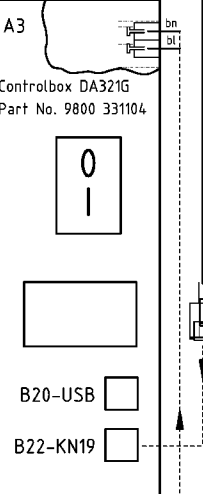
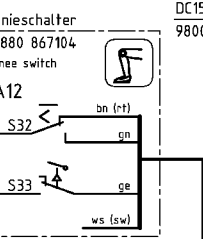

c		Datum	05.02.10
b		Bearb.	Cz
a	01.0	20.01.2011	Cz
Änd.	Datum	Name	Norm

DURKOPP ADLER

Teilefamilie
Freigabe 0001/11

Kl. 867; 868; 669; 869; 667
M-Type

Bauschaltplan
9890 867001 B

Blatt 1 / 1

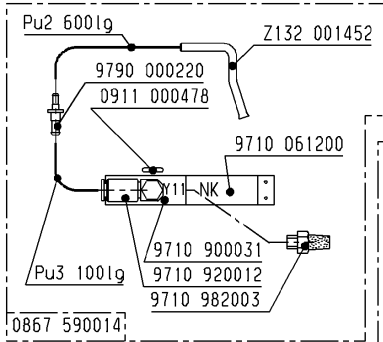
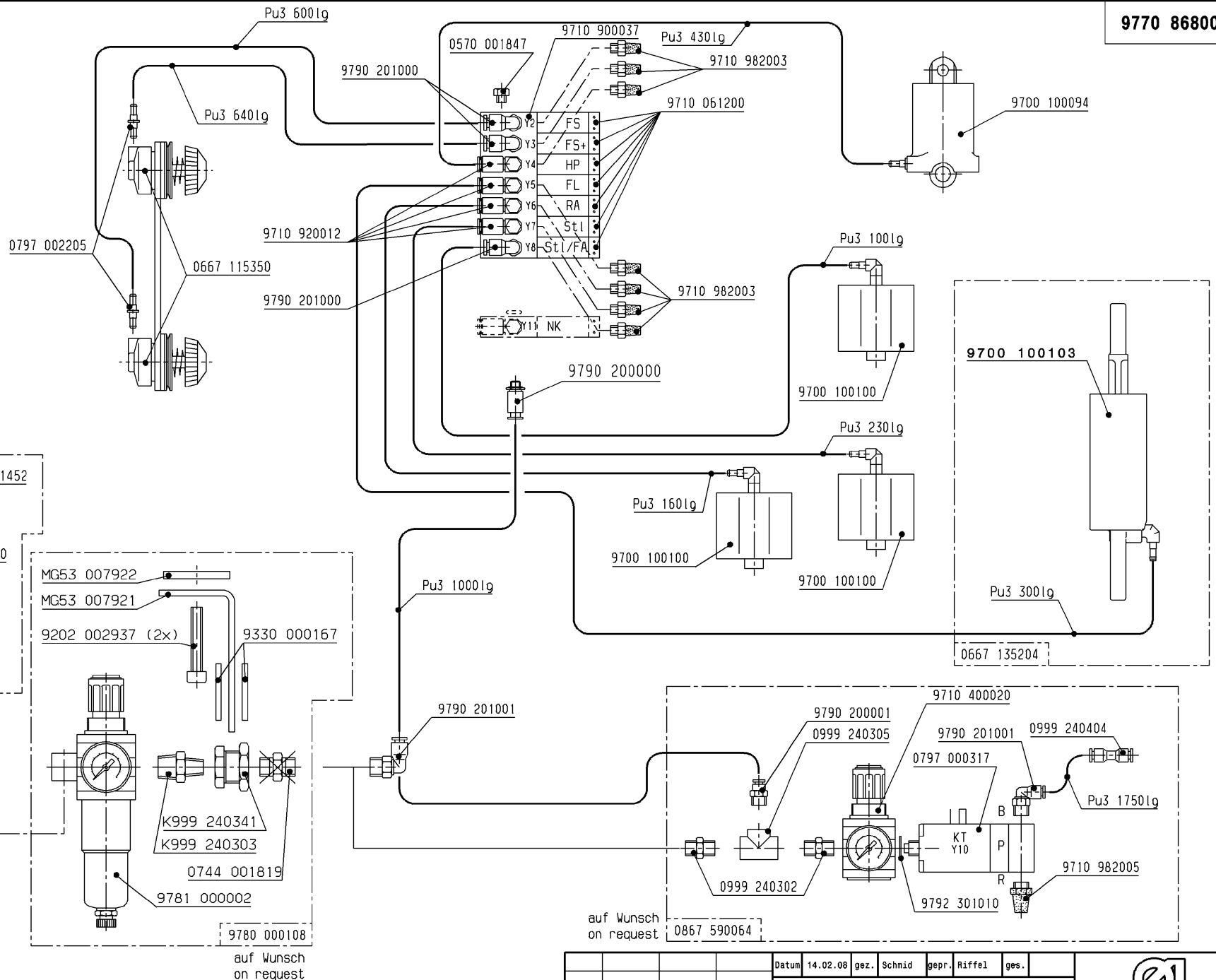

auf Wunsch
on request

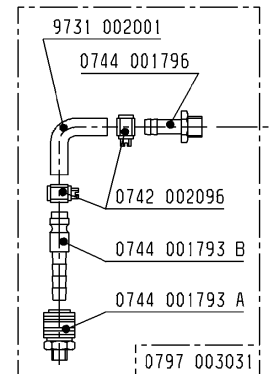

auf Wunsch
on request

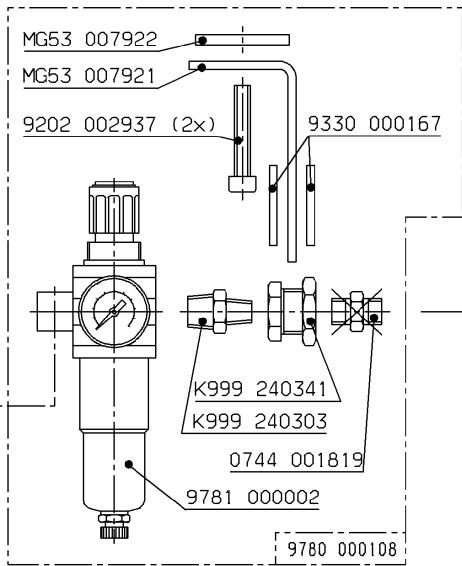

auf Wunsch
on request

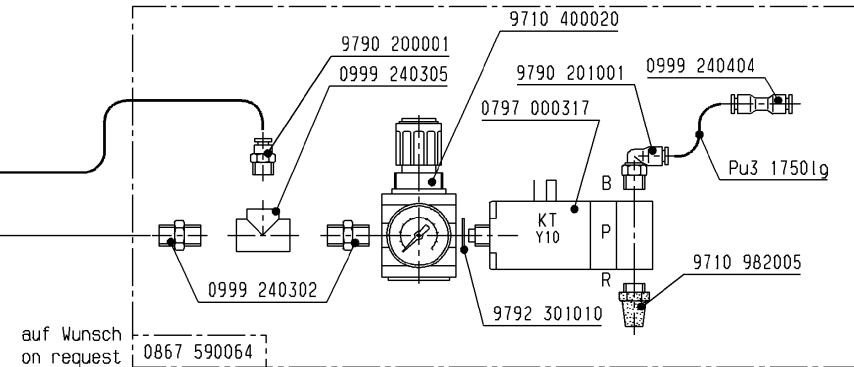

auf Wunsch
on request

Schlauch Hose	Teile-Nr. (Meterware) Part-No. (Yarded goods)
PU2	0699 979265
PU3	9731 005004

Datum	14.02.08	gez.	Schmid	gepr.	Riffel	ges.
01.0	13.01.10	Pasek P.	Ondrousek			
Änd.	Datum	gez.	gepr.			

Pneu.-Geräteplan für
Pneu.-Elements-Plan for
0868-1903.. 0868-3903..
0868-2903..

DÜRKOPP ADLER AG

9770 868001
 Blatt 1 Blattz. 2