

3371^{-1/..}
^{-10/..}

TEILELISTE

PARTS LIST

LISTE DE PIÈCES

零件表

Diese Teileliste hat für Maschinen ab nachfolgender
Seriennummer Gültigkeit:

This parts list applies to machines from the following
serial numbers onwards:

Cette liste de pièces est valable pour les machines au
numéros de série à partir de:

本零件表对从下列系列号起的机器有效:

60 801 005 →

Alle Informationen und Abbildungen waren zum Zeitpunkt der Druckgebung auf dem neusten Stand.

Technische Änderungen vorbehalten!

Der Nachdruck, die Vervielfältigung sowie die Übersetzung - auch auszugsweise - aus PFAFF-Teilelisten ist nur mit unserer vorherigen Zustimmung und mit der Quellenangabe gestattet.

At the time of printing, all information and illustrations contained in this document were up to date.

Subject to alteration!

The reprinting, copying or translation of PFAFF Parts lists whether in whole or in part, is only permitted with our previous permission and with written reference to the source.

Todas las informaciones e ilustraciones de este manual estaban al día en el momento de entregarse para su impresión.

¡ Salvo modificaciones técnicas!

La reimpresión, reproducción y traducción - aunque sólo sea parcial - de las listas de piezas PFAFF sólo está permitida con nuestro permiso previo e indicando la fuente.

所有信息和图片在付印时都是最新的。

保留技术更改的权力！

全部或部分翻印、复制以及翻译PFAFF-零件表必须事先经由我们同意并且注明来源。

**PFAFF Industriesysteme
und Maschinen AG**

Hans-Geiger-Str. 12 - IG Nord

D-67661 Kaiserslautern

	Seite Page Página 页号
0 Wichtiger Hinweis	0 - 1
Important note	
Observación importante	
重要提示	
1 Vorwort	1 - 1
Foreword	
Notas preliminares	
前言	
2 Erläuterungen der Schlüsselzeichen	2 - 1
Explanation of key markings	
Explicaciones de los signos clave	
标记说明	
3 Basismaschine	
Basic machine	
Máquina básicas	
基础机器	
3.01 Gehäuseteile	3 - 1
Housing sections	
Piezas del cárter	
机身零件	
3.02 Kopfteile	3 - 2
Needle head parts	
Piezas de la cabeza	
机头零件	
3.03 Armteile	3 - 5
Arm parts	
Piezas del brazo	
机臂零件	
3.04 Freiarmteile	3 - 11
Cylinder bed parts	
Piezas del brazo al aire	
悬臂部分的零件	

4	Elektrische Ausrüstung Electrical equipment Equipo eléctrico 电设备		
4.01	Kabelbaum zum Oberteil	4	- 1
	Cable tree to sewing head Mazo de cables para el cabezal 上部机器电缆束		
4.02	Oberteilerkennung	4	- 2
	Sewing head identification Detección de la parte superior 机头识别		
4.03	Einbaumotor	4	- 2
	Built-in motor Motor incorporado 内装式电机		
4.04	Bedienfeld	4	- 3
	Control panel Panel de mandos 操作板		
4.05	Sollwertgeber	4	- 4
	Set-point generator Emisor del valor teórico 给定值发生器		
4.06	Motor-Hauptschalter	4	- 5
	Main switch Interruptor principal 电机主开关		
4.07	Steuerkasten	4	- 6
	Control box Caja de mandos 控制箱		

	Seite Page Página 页号
5 Garnrollenständer	5 - 1
Reel stands	
Portacarretes	
线轴支架	
6 Schmiermittel-Übersicht	6 - 1
Overview of lubricants	
Tabla de lubricantes	
润滑剂一览	
7 Abweichende Teile der PFAFF 3371-10/..	7 - 1
Different parts for PFAFF 3371-10/..	
Piezas de la PFAFF 3371-10/.. que son diferentes	
PFAFF 3371-10/.. 中有差别的零件	
8 Index (Teilenummern / Seitenzahlen)	8 - 1
Index (part numbers / page numbers)	
Index (números de pieza / números de página)	
注脚(零件号/页号)	
9 Unterklassen-Ausstattung	
Subclass parts	
Composición de las subclases	
子机型-设备	
9.01 Nähwerkzeuge (PFAFF 3371-1/..)	9 - 2
Gauge parts (PFAFF 3371-1/..)	
Organos de costura (PFAFF 3371-1/..)	
缝纫工具 (PFAFF 3371-1/..)	
9.02 Nähwerkzeuge (PFAFF 3371-10/..)	9 - 5
Gauge parts (PFAFF 3371-10/..)	
Organos de costura (PFAFF 3371-10/..)	
缝纫工具 (PFAFF 3371-10/..)	

Achtung!



Wir machen ausdrücklich darauf aufmerksam, daß Ersatz- und Zubehörteile, die nicht von uns geliefert werden, auch nicht von uns geprüft und freigegeben sind. Der Einbau und / oder die Verwendung solcher Produkte kann daher u. Umständen konstruktiv vorgegebene Eigenschaften Ihrer Maschine negativ verändern. Für Schäden, die durch die Verwendung von Nicht-Originalteilen entstehen, übernehmen wir keine Haftung!
Originalteile sind mit einem " **P** " oder der **PFAFF-Teilenummer** gekennzeichnet.

Caution!



We warn you expressively that spare parts and accessories that are not supplied by us are not tested and released by us. Fitting or using these products may therefore have negative influences on features that depend on the machine design.
We are not liable for any damage caused by the use of non-Pfaff parts!
Original parts are marked with a " **P** " or with the **PFAFF part number**.

¡Atención!



Se hace observar que en el caso de piezas de recambio y accesorios que no hayan sido suministrados por nosotros, quiere decir que non han sido sometidas por nuestra parte a un control y que no se les ha dado el visto bueno. Por esta razón, el montaje y/o empleo de tales productos puede repercutir negativamente en las características previstas en su máquina.
¡Para los daños que eventualmente pudiesen presentarse al utilizar piezas no originales, no asumimos ninguna garantía!
Las piezas originales se identifican con " **P** " o con el número de referencia de pieza de **PFAFF**.

注意!



我们必须明确指出，所有不是由我们供货的备件和附件都未经我们检查，也没有被我们批准使用。装入和/或使用这些产品可能在一定的情况下会对机器的设计特性造成负面改变。对由于使用非原装件所造成的损失，我们不负任何责任！
原装零件用字母 " **P** " 或者 **PFAFF** 零件号加标记。

- Die Seriennummer der Maschine, für die diese Teileliste Gültigkeit hat, ist auf der Titelseite aufgeführt.
 - Alle Teile sind so abgebildet, wie sie in der Maschine funktionsmäßig zusammengehören.
 - Gestrichelt dargestellte Teile zeigen angrenzende Teile aus anderen Funktionsgruppen.
 - Im oberen Teil der Bildseiten befindet sich eine Gesamtansicht der Maschine .
 - Der Einbauort der dargestellten Teile wird durch eine gerasterte Fläche gekennzeichnet.
 - Einrahmungen auf den Bildseiten zeigen, aus welchen Einzelteilen sich die Gruppenteile zusammensetzen.
 - Die auf den Bildseiten verwendeten Schlüsselzeichen (; 2 ; 3 usw.) sind im Kapitel "Erläuterungen der Schlüsselzeichen" aufgelistet.
-
- The serial number of the machine to which this parts list applies is indicated on the cover page.
 - All parts are illustrated in function groups with the parts which they function together with in the machine.
 - Parts illustrated with broken lines are parts from other function groups which border on the illustrated function group.
 - The above section of the page of illustrations contains a total view of the machine. The place for the installation of the parts pictured here is marked by the grid.
 - The framed-in sections on the illustration pages show the individual parts comprising a group.
 - The key markings used on the illustrated pages (; 2 ; 3 etc.) are listed in the chapter "Explanation of key markings".
-
- El número de serie de la máquina para la cual tiene validez esta lista de piezas va indicado en la página de título.
 - Todas las piezas están ilustradas tal como aparecen en la máquina para su funcionamiento.
 - Las piezas representadas con rayitas muestran piezas colindantes de otros grupos de funciones.
 - En la parte superior de las páginas ilustradas se puede ver una vista en conjunto de la máquina.
 - El lugar de montaje de la pieza representada va caracterizada mediante una superficie reticulada.
 - Los recuadros en las páginas ilustradas indican las piezas individuales de que se componen los grupos.
 - Los signos clave (; 2 ; 3 etc.) empleados en las páginas con ilustraciones van listados en el capítulo "Explicaciones de los signos clave".
-
- 适用于本零件表的机器系列号列在首页上。
 - 所有的零件都按照其在机器中的功能情况合在一起表达。
 - 用虚线表示的零件为相邻功能组中的零件。
 - 图的上部为机器全景。
 - 所示零件的安装部位用影格面表示。
 - 页上的框表示这套组件都由哪些零件所组成。
 - 图页上所使用的标记 (; 2 ; 3 等) 列表在“标记说明”中。

- **Unterklassenabhängig, Teilenummer siehe Unterklassen-Ausstattung.**
Subclas-dependent, for part number see subclass parts listing.
Dependientes de la subclase, para el número de pieza véase "Dotación de subclases".
取决于子机型，零件号见子机型设备。
- 3** **Geklebt**
Part cemented
Pieza pegada
被粘住
- 6** **Nadeldicke und Spitzenform bei Bestellung angeben.**
Needle size and style of point to be stated on order.
Grosor de aguja y forma de la punta, indíquese en los pedidos.
在订货时给出针厚和针尖型式。
- 40/24** **Ölen mit 28-011 201-05; Bestellnummer siehe Seite 6 - 1.**
Oil with 28-011 201-05; for part number see page 6 - 1.
Lubrifique con grasa 28-011 201-05; para el número de pedido véase la página 6 - 1.
上油用 28-011 201-05; 订货号见 6 - 1页。
- 40/26** **Füllen mit 28-011 201-05; Bestellnummer siehe Seite 6 - 1.**
Top up with 28-011 201-05; for part number see page 6 - 1.
Rellene con 28-011 201-05; para el número de pedido véase la página 6 - 1.
注油用 28-011 201-05; 订货号见 6 - 1页。
- 40/27** **Tränken mit 28-011 201-05; Bestellnummer siehe Seite 6 - 1.**
Grease with 28-011 201-05; for part number see page 6 - 1.
Engrase con grasa 28-011 201-05; para el número de pedido véase la página 6 - 1.
浸油用 28-011 201-05; 订货号见 6 - 1页。
- 96** **Länge angeben**
State length
Indíquese la largura
给出长度

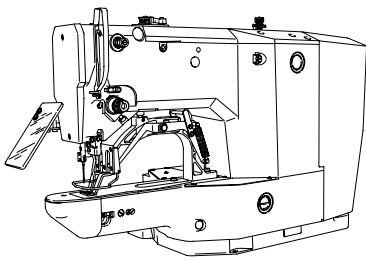

Gehäuseteile
Housing sections
Piezas del cárter
机身零件

PFAFF 3371-1/..

3.01

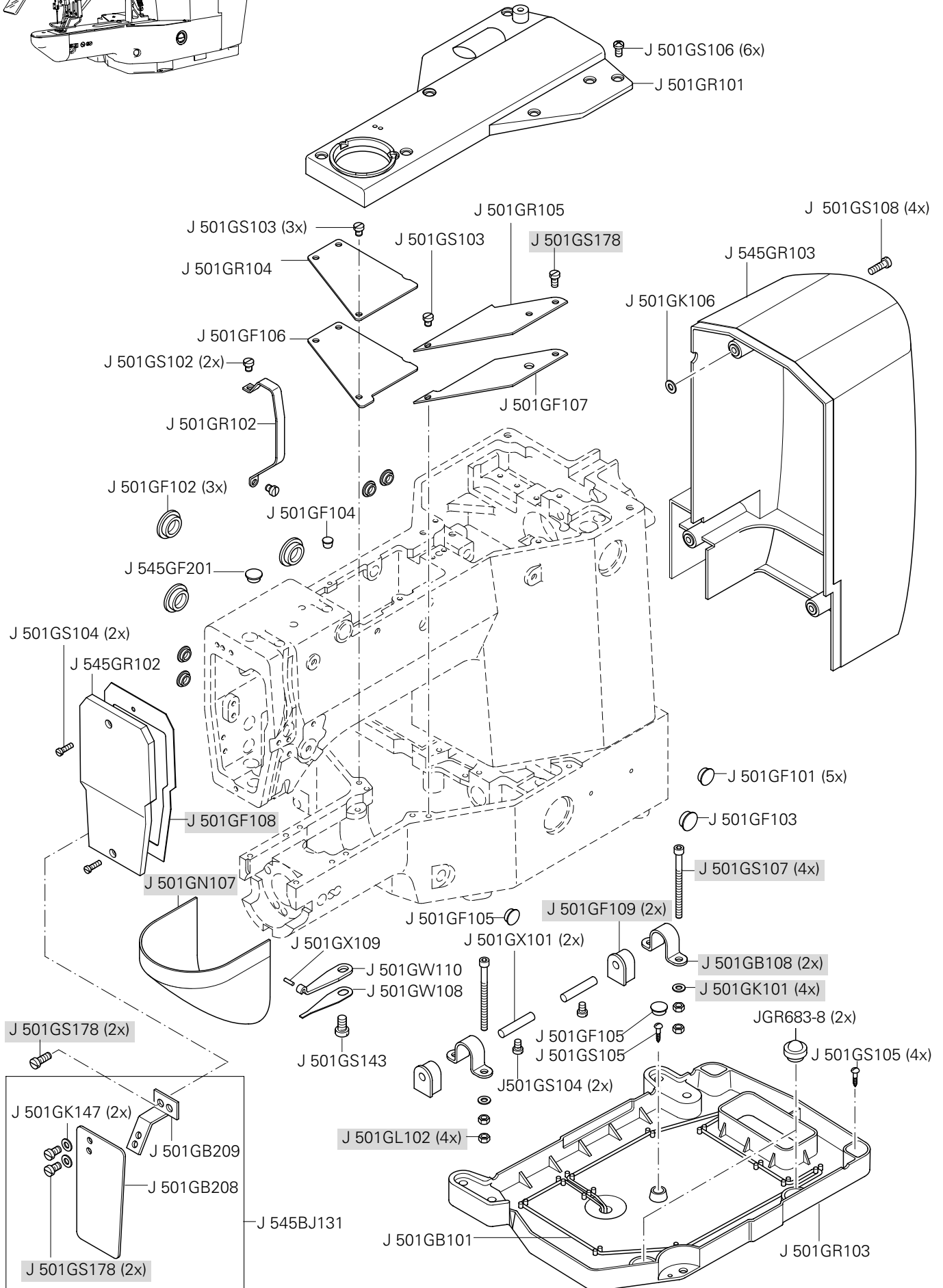

siehe Kapitel 2 Erläuterung der Schlüsselzeichen
 see chapter 2 Explanation of key markings
 véase el Cap. 2 Explicaciones de los signos clave
 见第2章标记说明

= als Ersatzteil lieferbar
 = available as spar part
 = para entregar como repuesto
 = 可以作为备件供货

3.02

Kopfteile Needle head parts Piezas de la cabeza 机头零件

PFAFF 3371-1/..

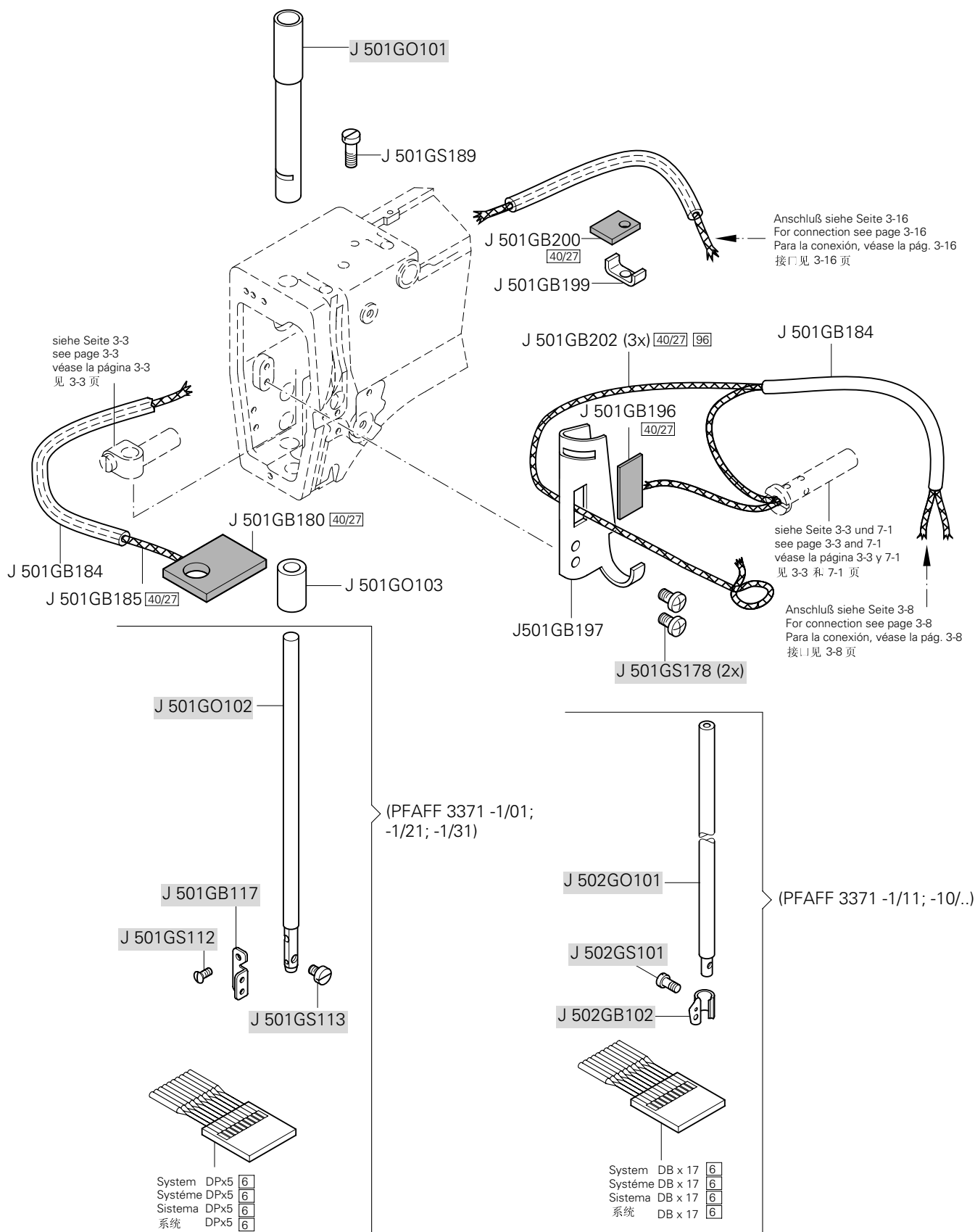
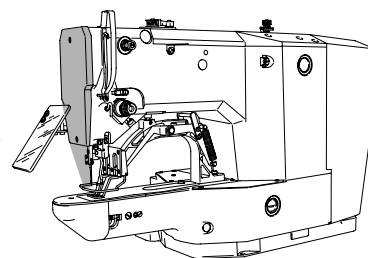

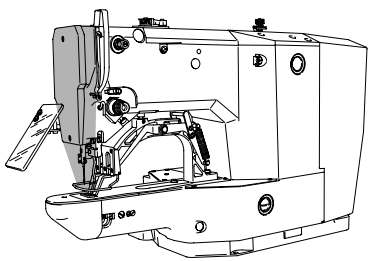

Kopfteile
Needle head parts
Piezas de la cabeza
机头零件

PFAFF 3371-1/..

3.02

Anschluß siehe Seite 3-8
For connection see page 3-8
Para la conexión, véase la pág. 3-8
接口 见 3-8 页

Für -10/.. siehe Seite 7-1
For -10/.. see page 7-1
Para -10/.. véase la página 7-1
适于 -10/.. 见 7-1 页

siehe Seite 3-6
see page 3-6
véase la página 3-6
见 3-6 页

siehe Seite 3-7
see page 3-7
véase la página 3-7
见 3-7 页

Für -10/.. siehe Seite 7-3
For -10/.. see page 7-3
Para -10/.. véase la página 7-3
适于 -10/.. 见 7-3 页

Für -10/.. siehe Seite 7-2
For -10/.. see page 7-2
Para -10/.. véase la página 7-2
适于 -10/.. 见 7-2 页

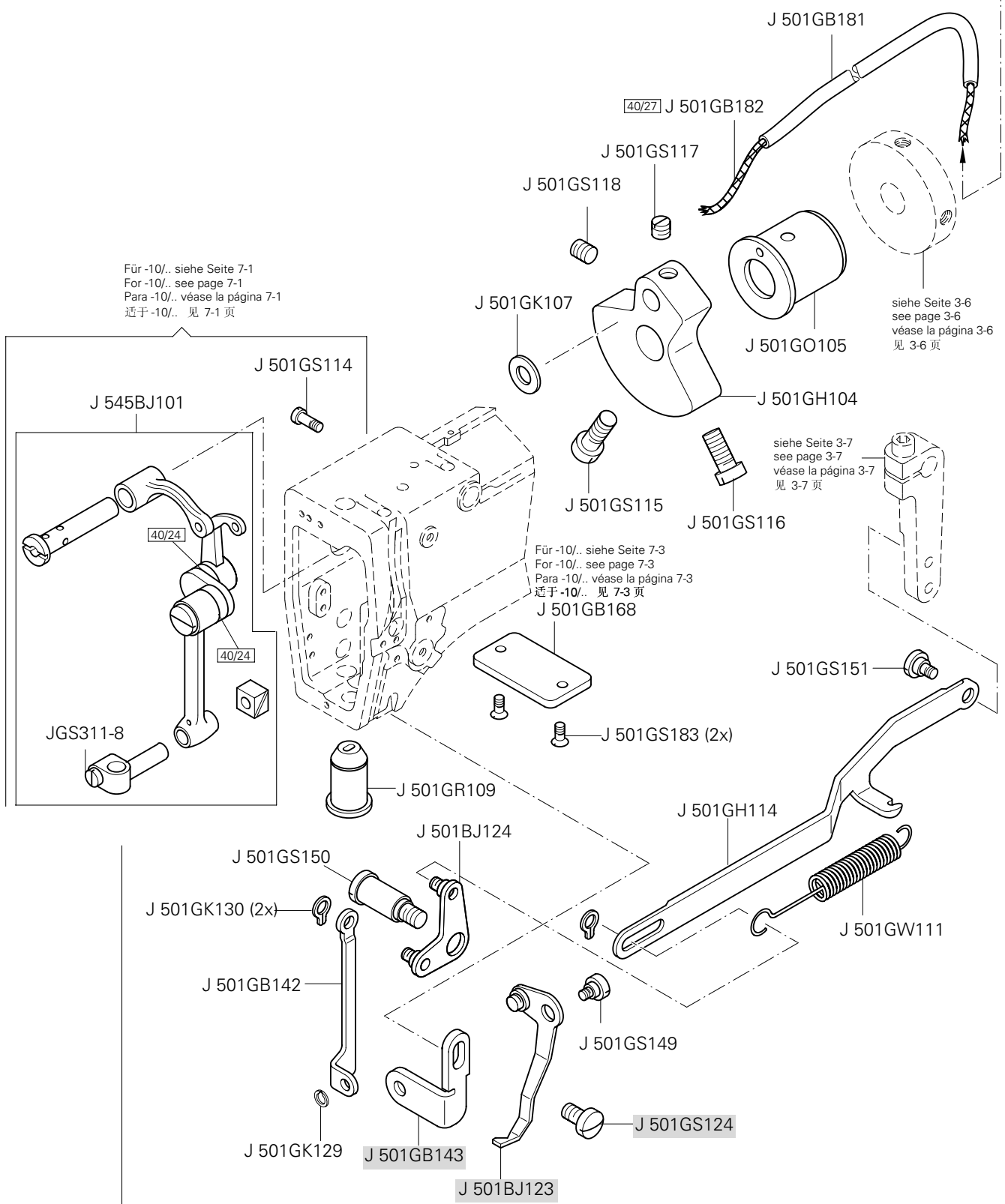

☐ siehe Kapitel 2 Erläuterung der Schlüsselzeichen
see chapter 2 Explanation of key markings
véase el Cap. 2 Explicaciones de los signos clave
见第2章标记说明

■ = als Ersatzteil lieferbar
= available as spar part
= para entregar como repuesto
= 可以作为备件供货

3.02

Kopfteile
Needle head parts
Piezas de la cabeza
机头零件

PFAFF 3371-1/..

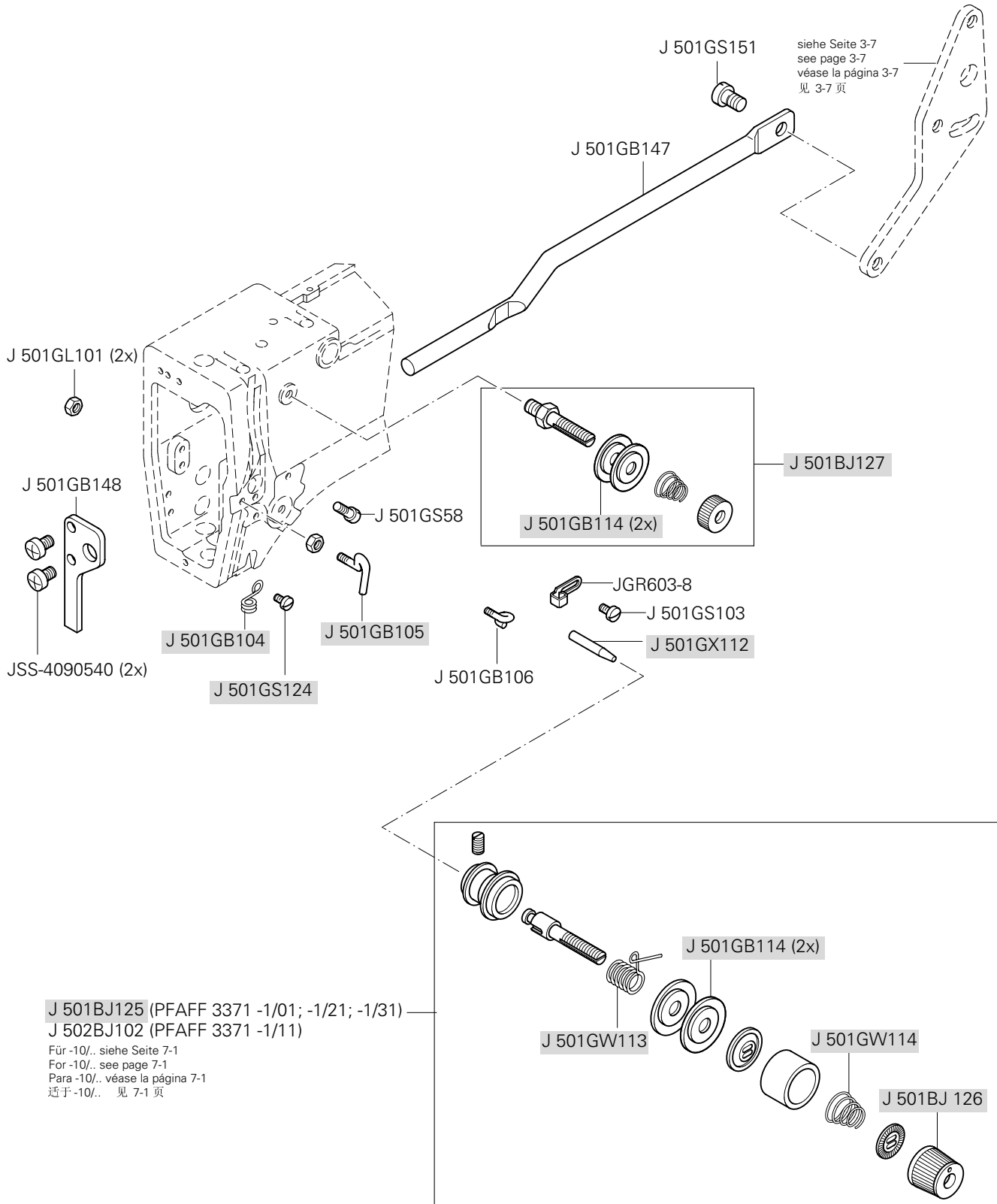
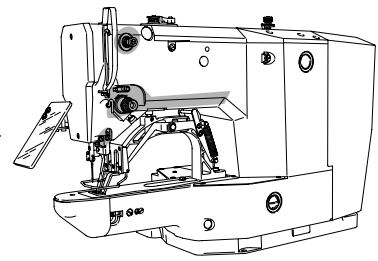

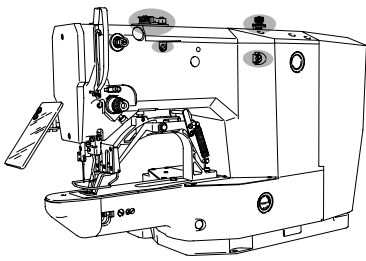

Armteile
 Arm parts
 Piezas del brazo
 机臂零件

PFAFF 3371-1/..

3.03

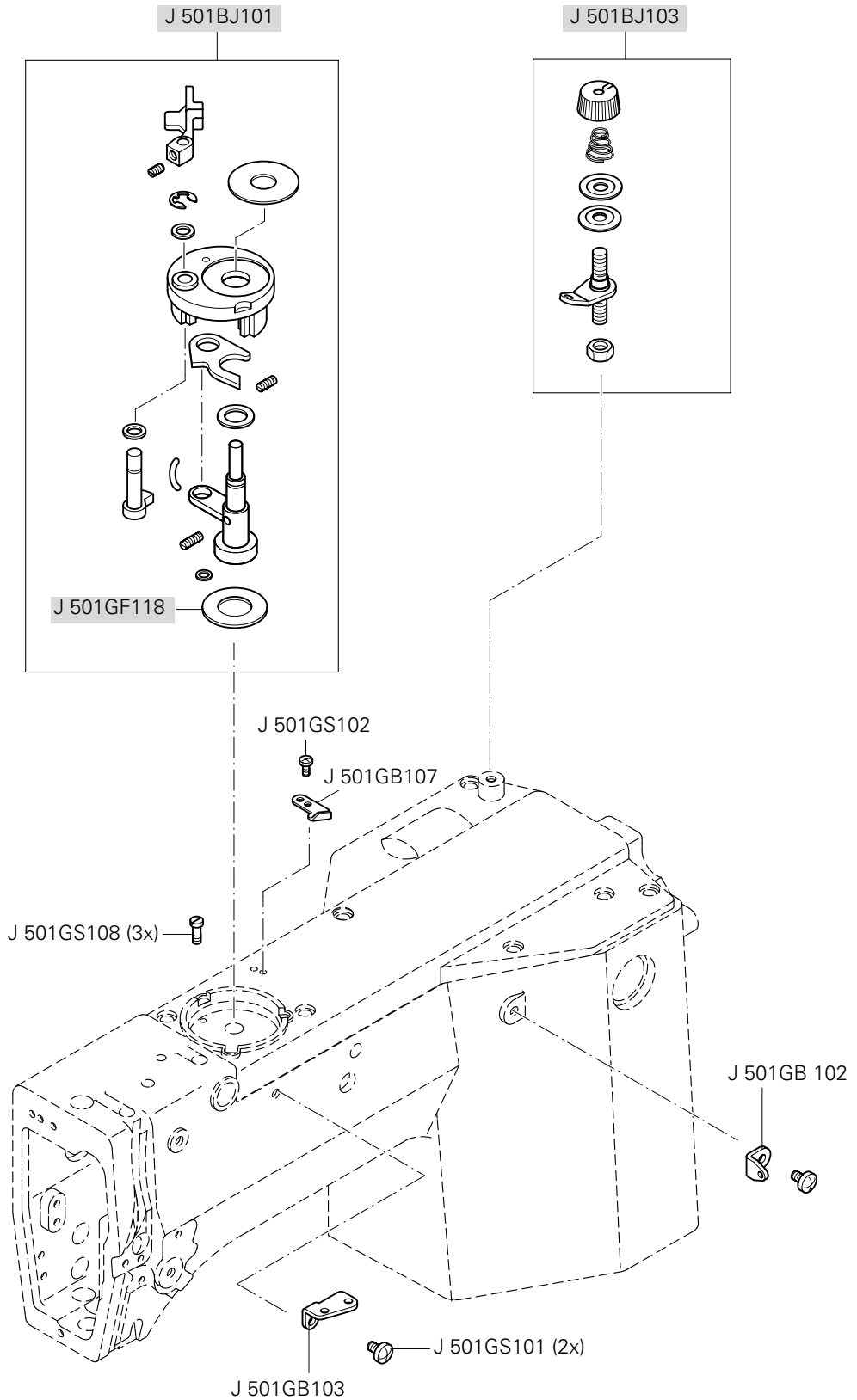

siehe Kapitel 2 Erläuterung der Schlüsselzeichen
 see chapter 2 Explanation of key markings
 véase el Cap. 2 Explicaciones de los signos clave
 见第2章标记说明

= als Ersatzteil lieferbar
 = available as spar part
 = para entregar como repuesto
 = 可以作为备件供货

3.03

Armteile Arm parts Piezas del brazo 机臂零件

PFAFF 3371-1/..

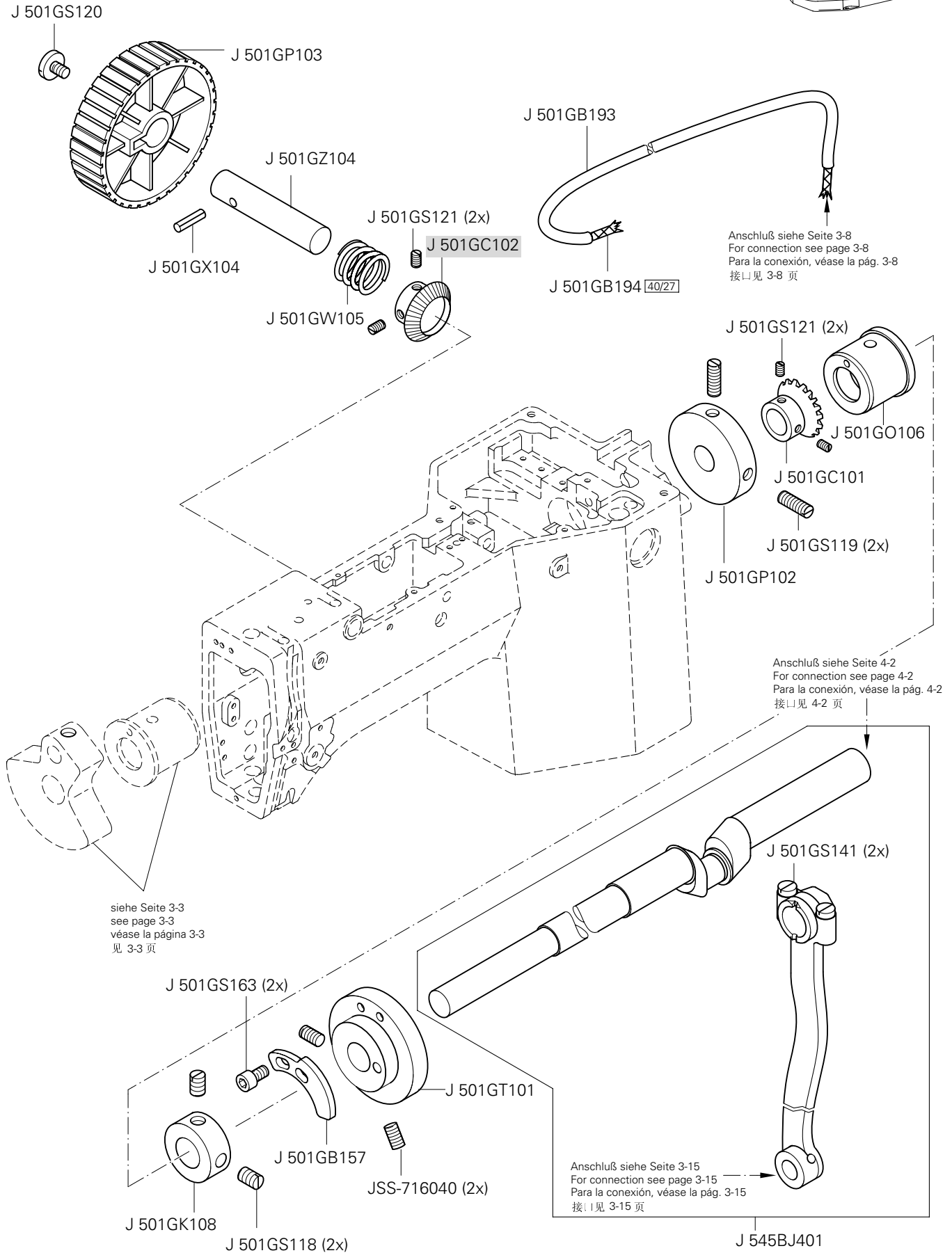
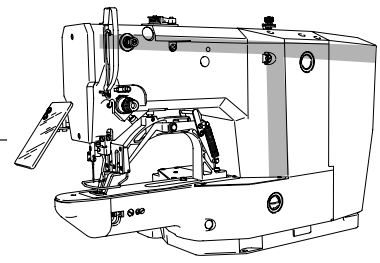

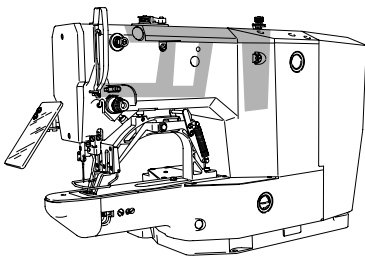

Armteile
 Arm parts
 Piezas del brazo
 机臂零件

PFAFF 3371-1/..

3.03

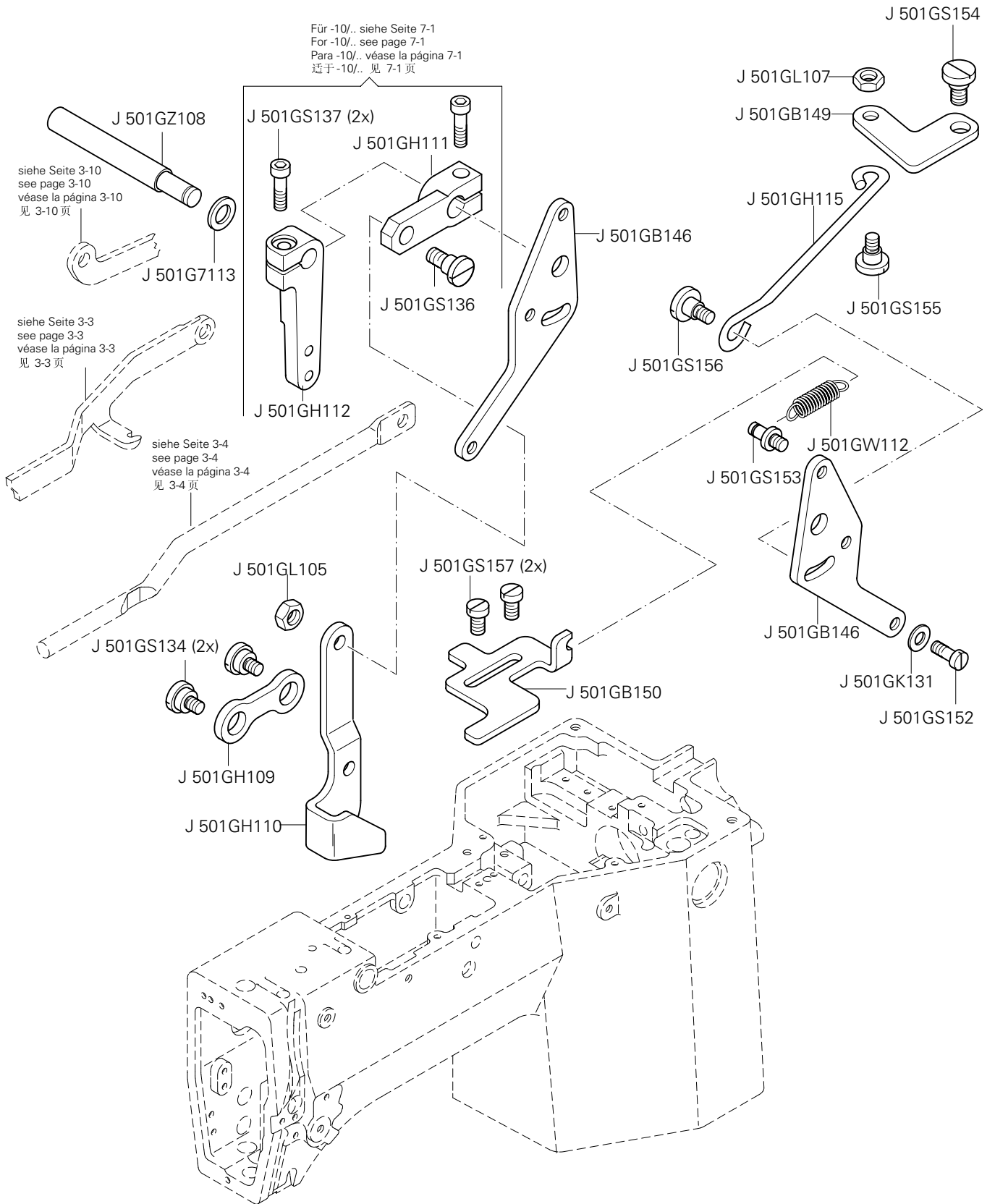

☐ siehe Kapitel 2 Erläuterung der Schlüsselzeichen
 see chapter 2 Explanation of key markings
 véase el Cap. 2 Explicaciones de los signos clave
 见第2章标记说明

■ = als Ersatzteil lieferbar
 = available as spar part
 = para entregar como repuesto
 = 可以作为备件供货

3.03

Armteile Arm parts Piezas del brazo 机臂零件

PFAFF 3371-1/..

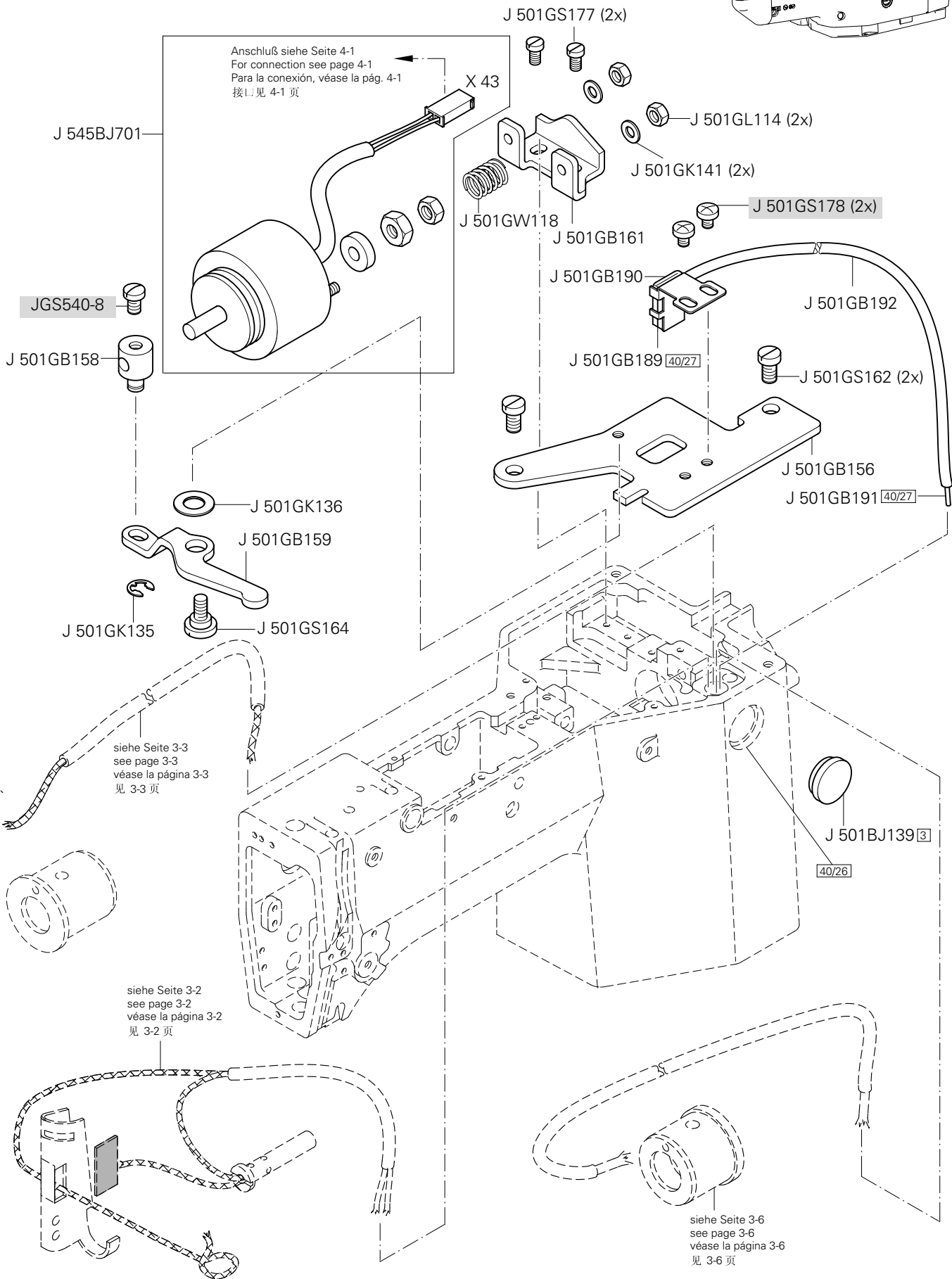
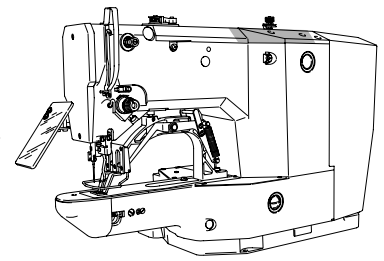

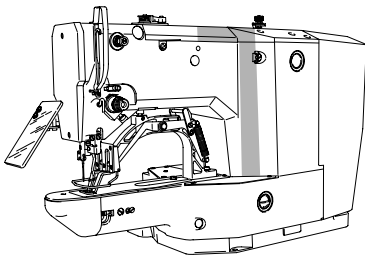

Armteile
 Arm parts
 Piezas del brazo
 机臂零件

PFAFF 3371-1/..

3.03

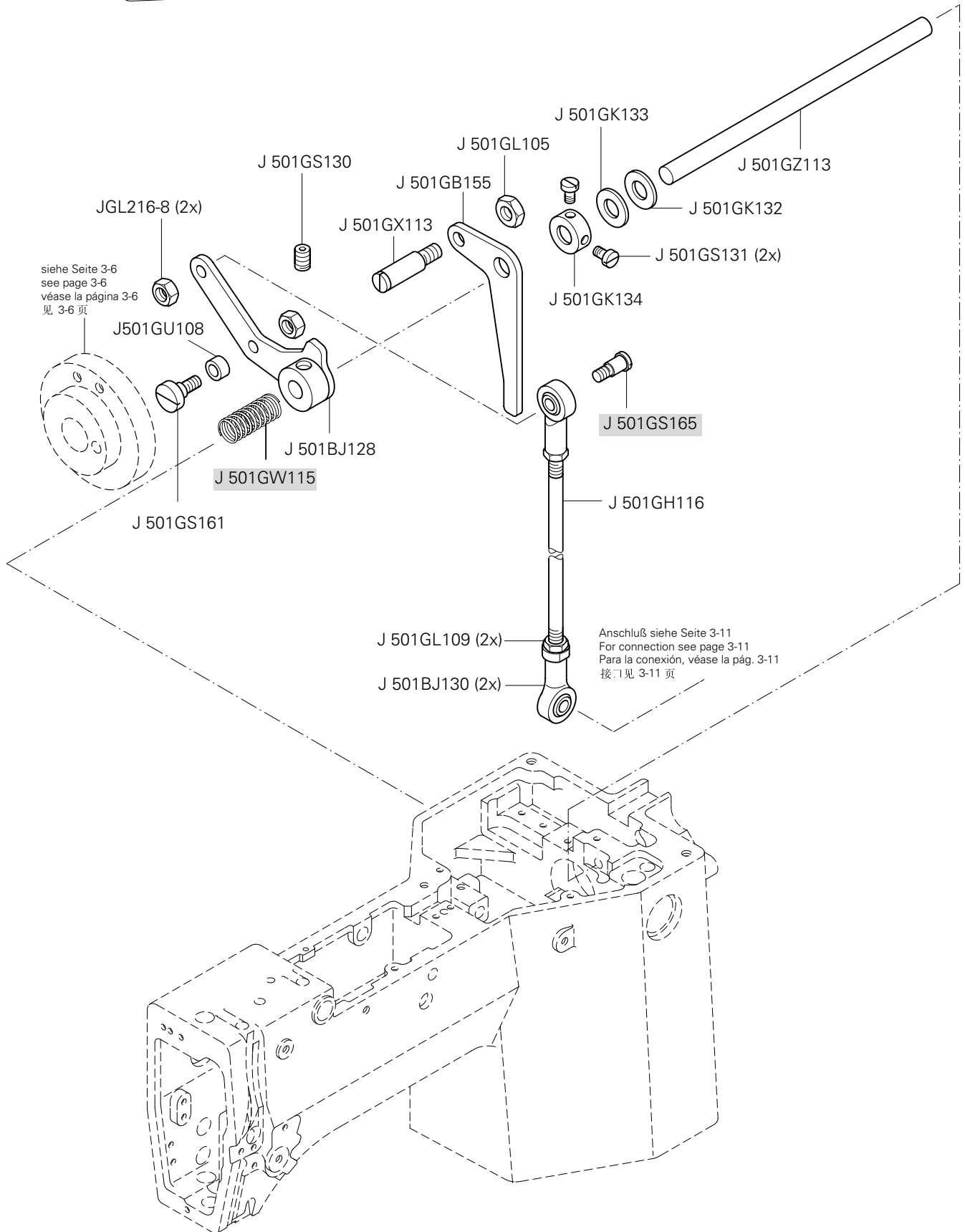

☐ siehe Kapitel 2 Erläuterung der Schlüsselzeichen
 see chapter 2 Explanation of key markings
 véase el Cap. 2 Explicaciones de los signos clave
 见第2章标记说明

■ = als Ersatzteil lieferbar
 = available as spar part
 = para entregar como repuesto
 = 可以作为备件供货

3.03

Armteile Arm parts Piezas del brazo 机臂零件

PFAFF 3371-1/..

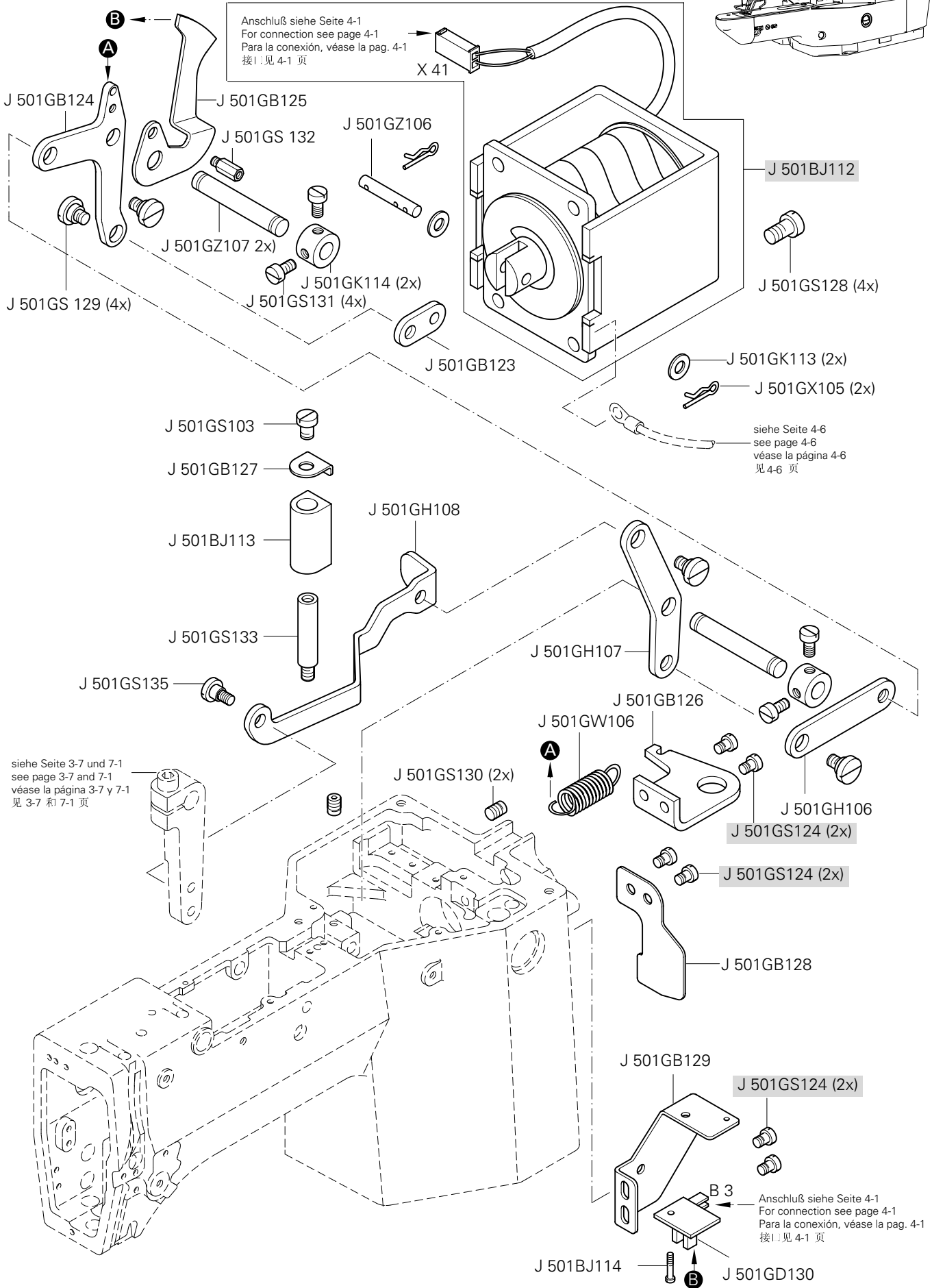
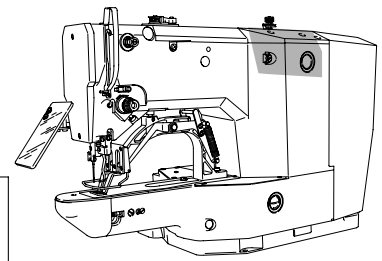

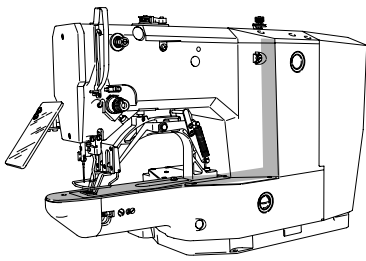

Freiarmteile
Cylinder bed parts
Piezas del brazo al aire
悬臂部分的零件

PFAFF 3371-1/..

3.04

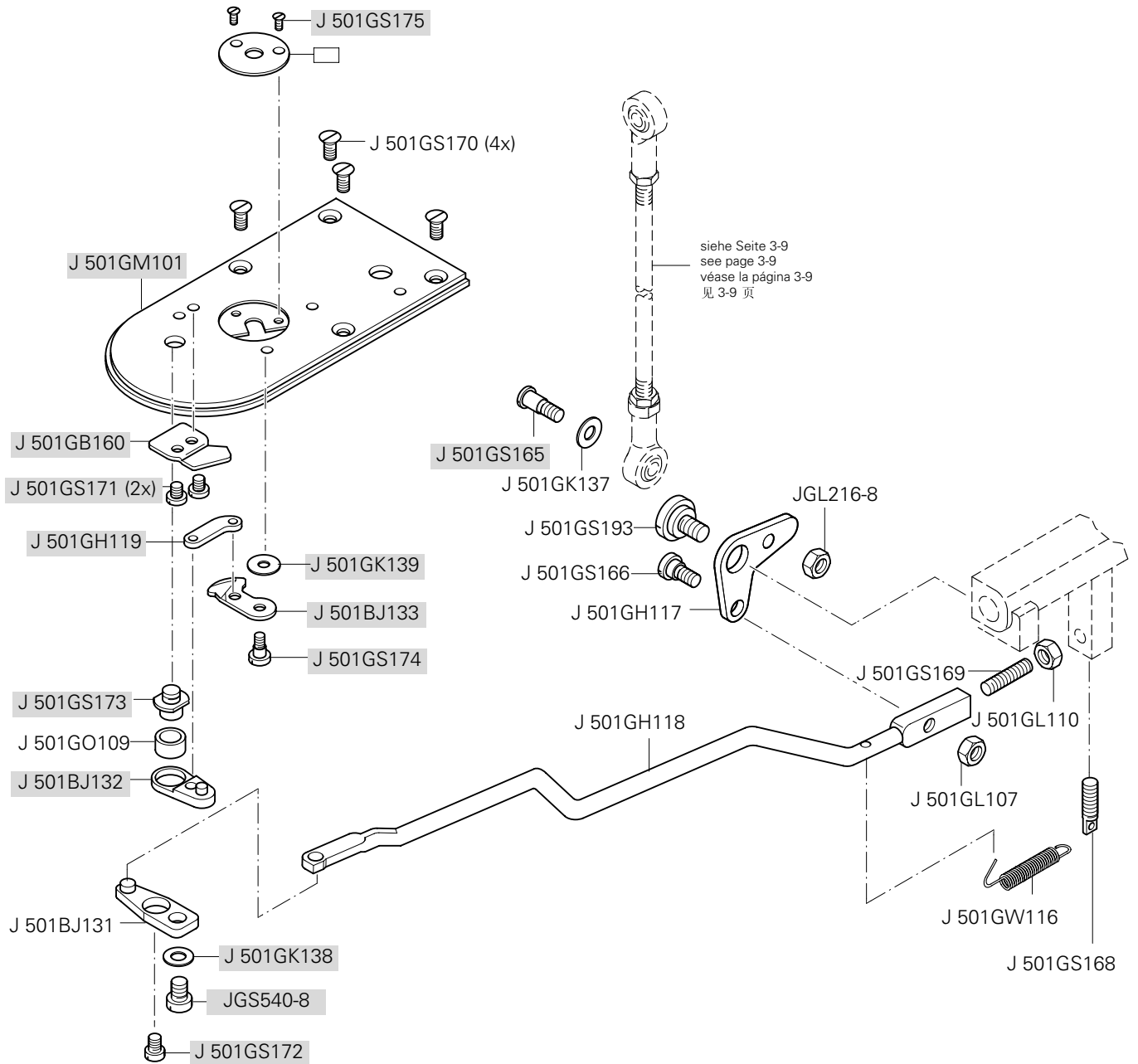

3.04

Freiarnteile Cylinder bed parts Piezas del brazo al aire 悬臂部分的零件

PFAFF 3371-1/..

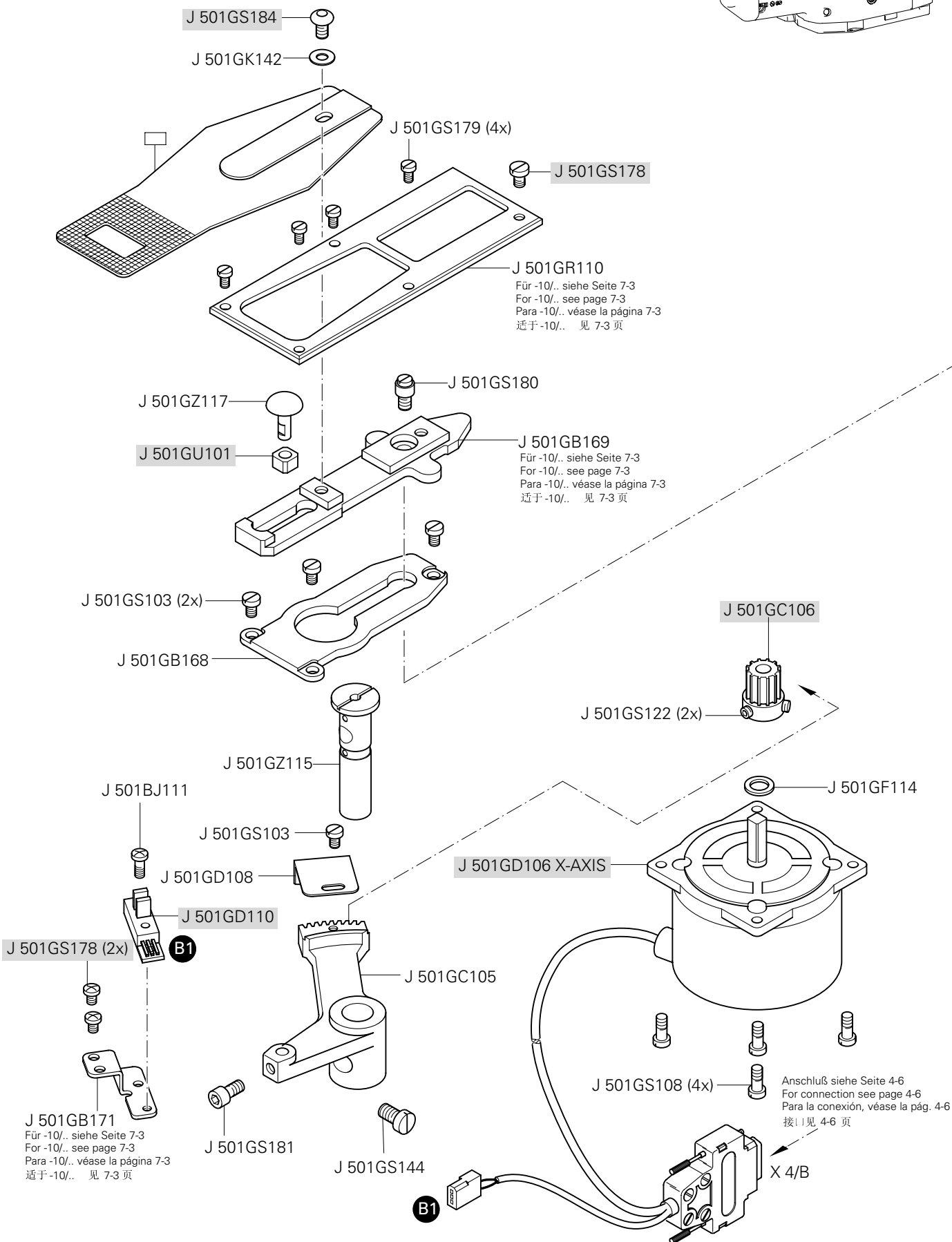
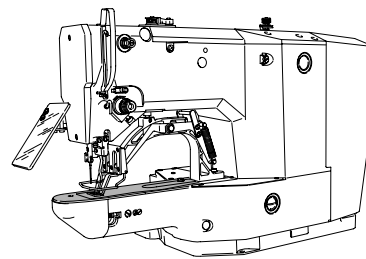

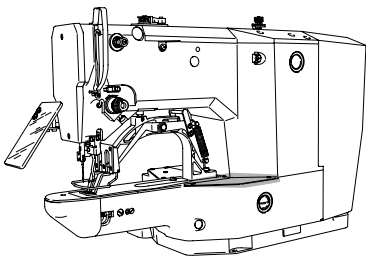

Freiarmteile
Cylinder bed parts
Piezas del brazo al aire
悬臂部分的零件

PFAFF 3371-1/..

3.04

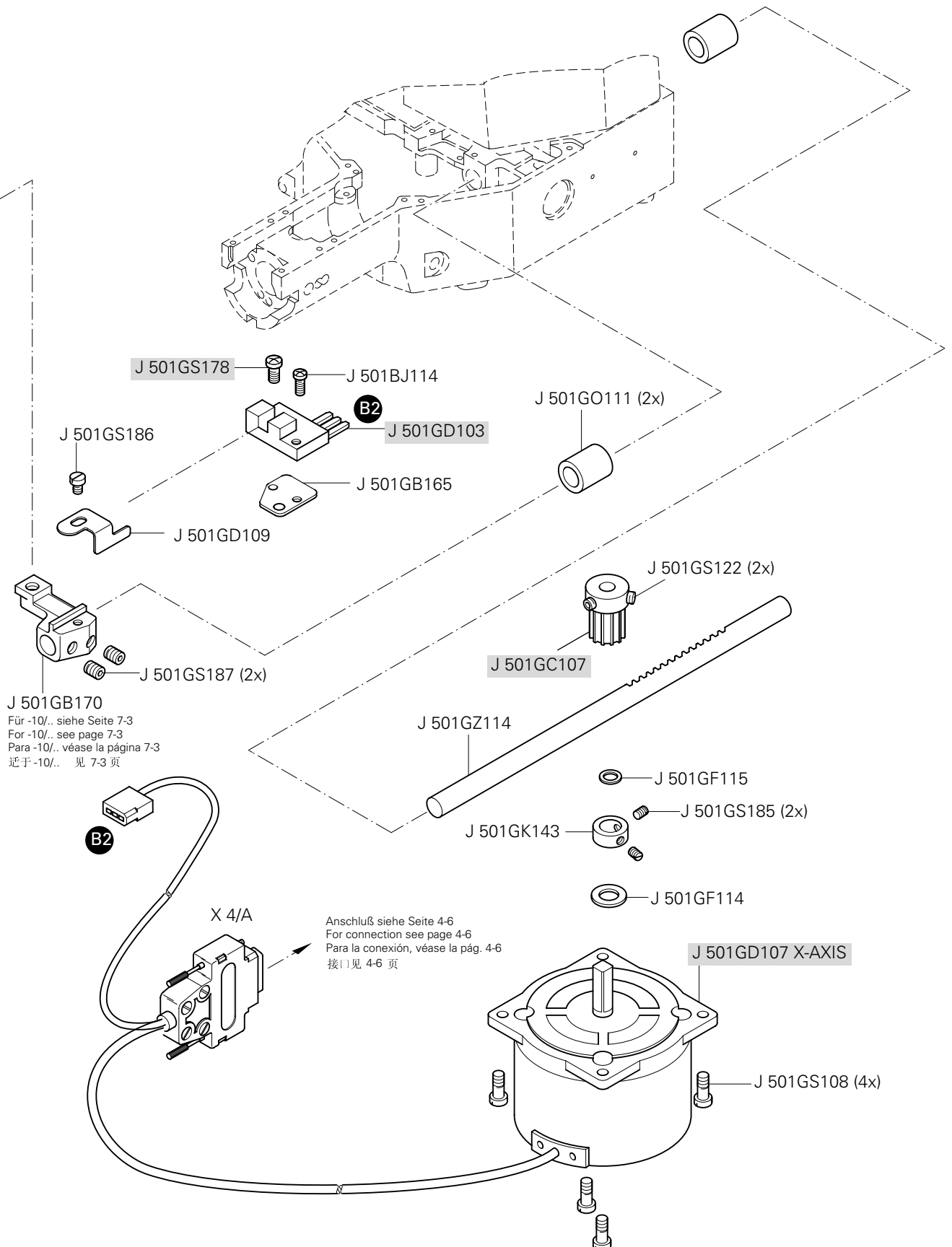

□ siehe Kapitel 2 Erläuterung der Schlüsselzeichen
 see chapter 2 Explanation of key markings
 véase el Cap. 2 Explicaciones de los signos clave
 见第2章标记说明

■ = als Ersatzteil lieferbar
 = available as spar part
 = para entregar como repuesto
 = 可以作为备件供货

3.04

Freiarnteile
Cylinder bed parts
Piezas del brazo al aire
悬臂部分的零件

PFAFF 3371-1/..

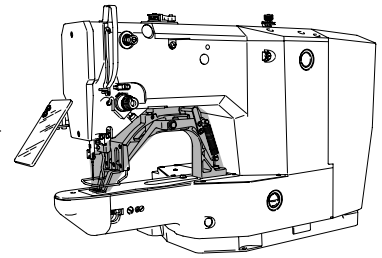

Für -10/.. siehe Seite 7-3
For -10/.. see page 7-3
Para -10/.. véase la página 7-3
对于 -10/.. 见 7-3 页

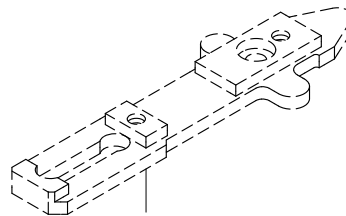
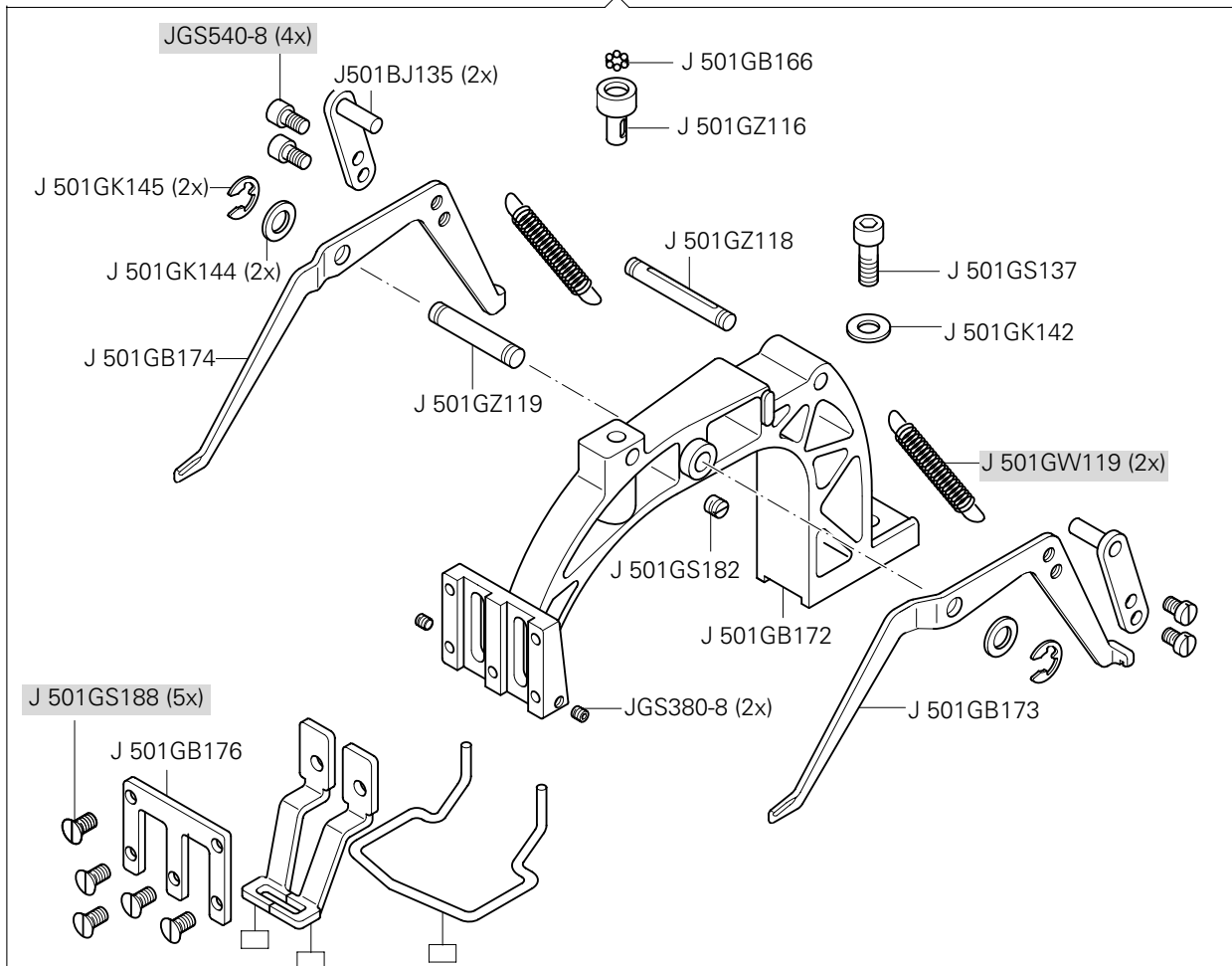

siehe Seite 3-12 und 7-3
see page 3-12 and 7-3
véase la página 3-12 y 7-3
见 3-12 和 7-3 页

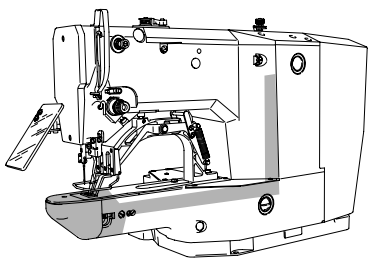

Freiarmteile
Cylinder bed parts
Piezas del brazo al aire
悬臂部分的零件

PFAFF 3371-1/..

3.04

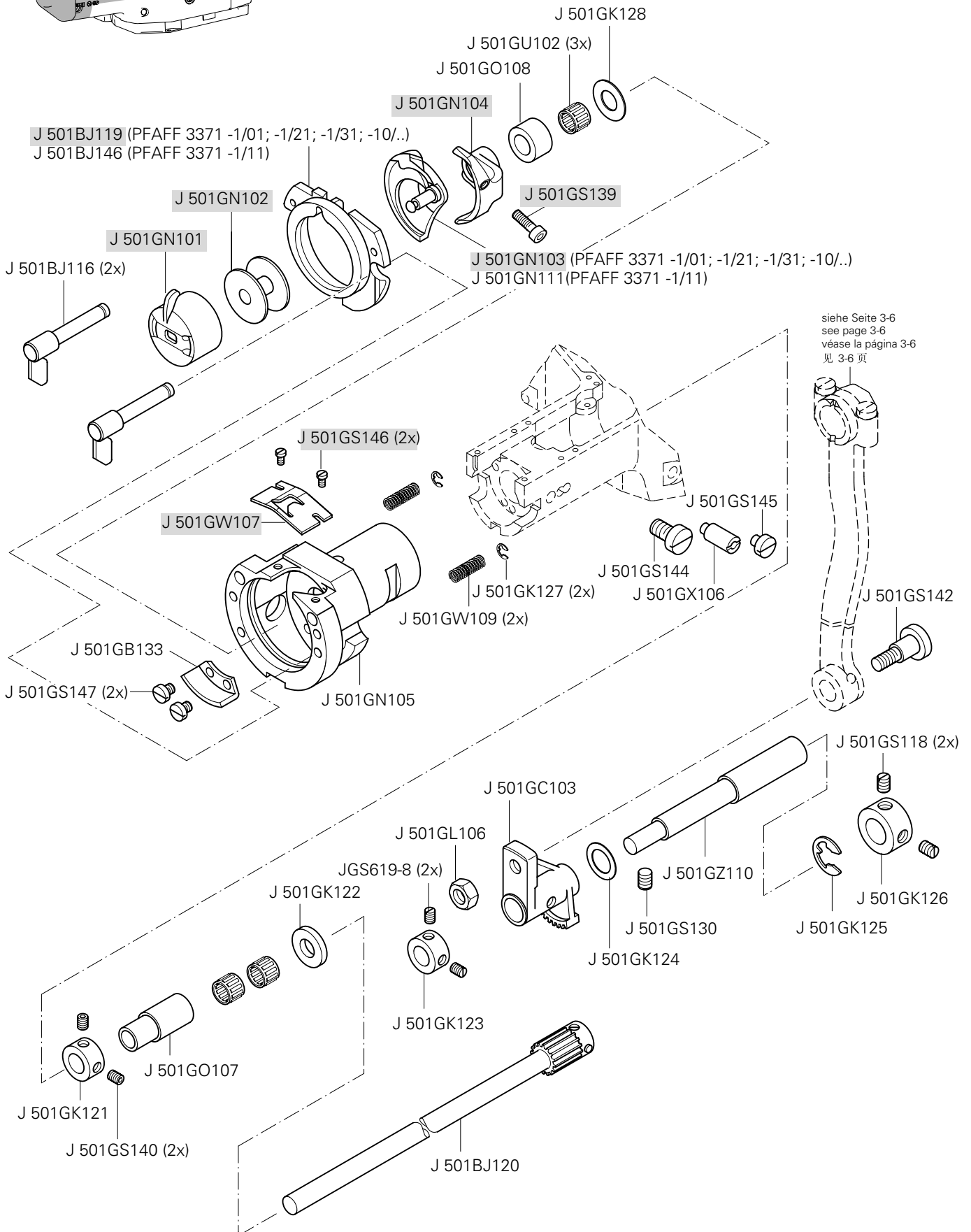

□ siehe Kapitel 2 Erläuterung der Schlüsselzeichen
see chapter 2 Explanation of key markings
véase el Cap. 2 Explicaciones de los signos clave
见第2章标记说明

■ = als Ersatzteil lieferbar
= available as spar part
= para entregar como repuesto
= 可以作为备件供货

3.04

Freiarmteile Cylinder bed parts Piezas del brazo al aire 悬臂部分的零件

PFAFF 3371-1/..

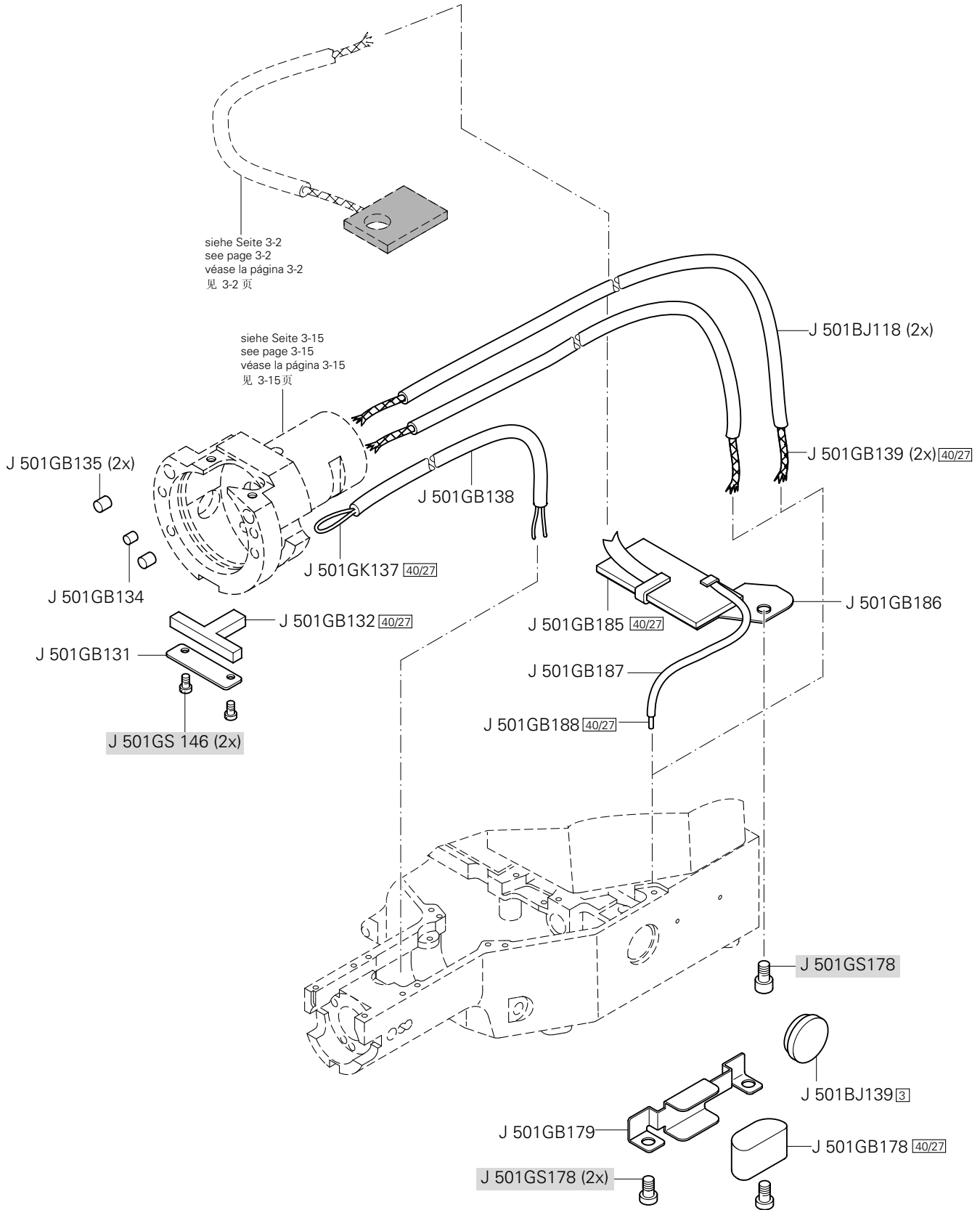
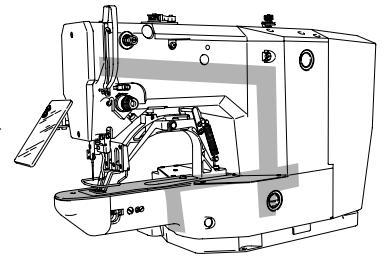

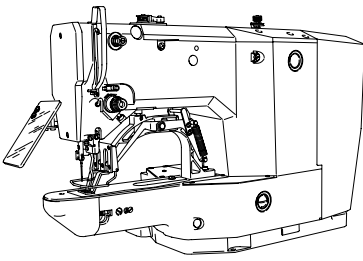

Kabelbaum zum Oberteil
 Cable tree to sewing head
 Mazo de cables para el cabezal
 上部机器电缆束

PFAFF 3371-1/..

4.01

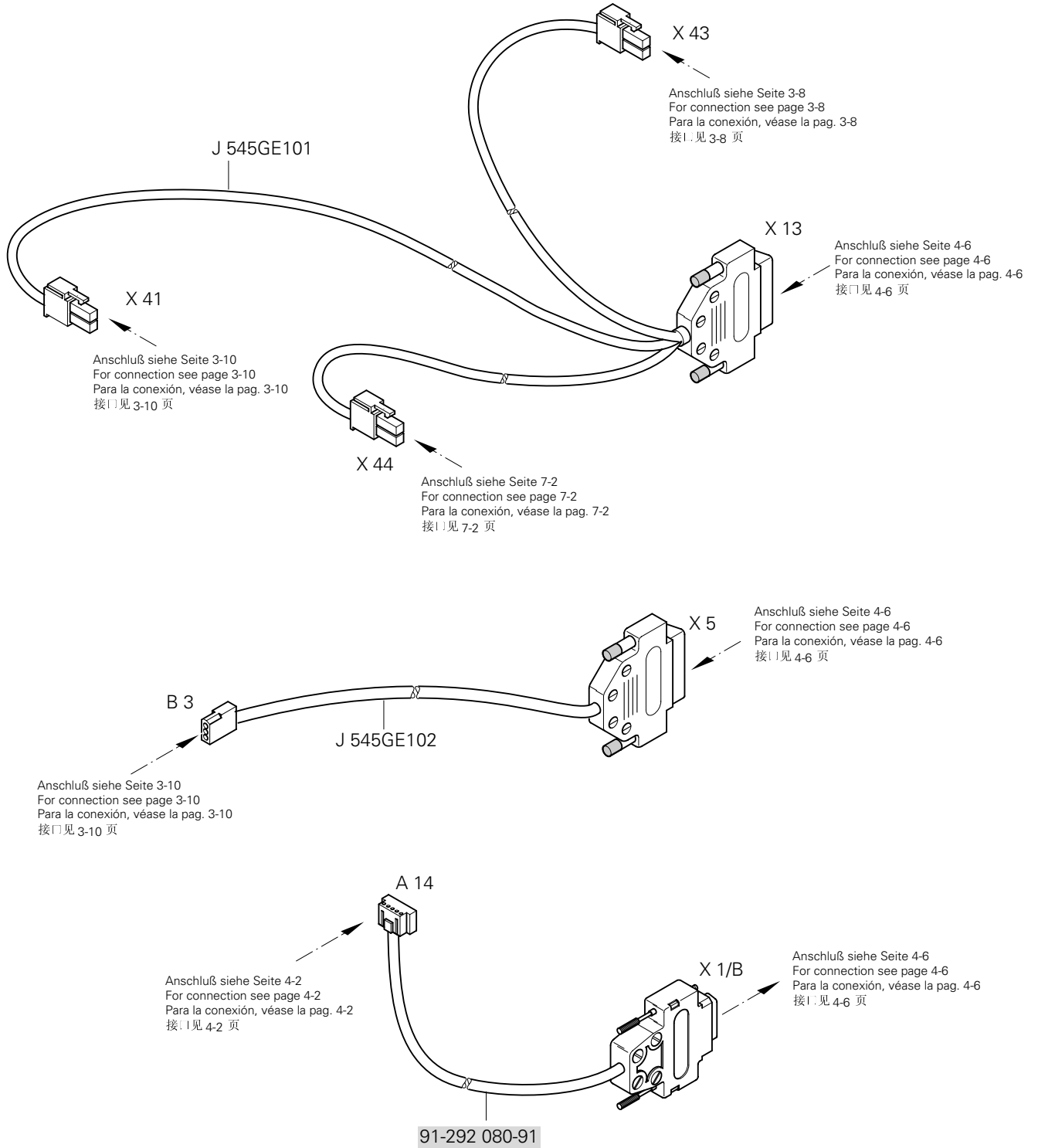

☐ siehe Kapitel 2 Erläuterung der Schlüsselzeichen
 see chapter 2 Explanation of key markings
 véase el Cap. 2 Explicaciones de los signos clave
 见第2章标记说明

■ = als Ersatzteil lieferbar
 = available as spar part
 = para entregar como repuesto
 = 可以作为备件供货

4.02

Oberteilerkennung
Sewing head identification
Detección de la parte superior
机头识别

PFAFF 3371-1/..

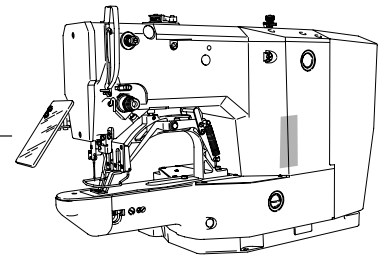

Anschluß siehe Seite 4-1
For connection see page 4-1
Para la conexión, véase la pág. 4-1
接口见 4-1 页

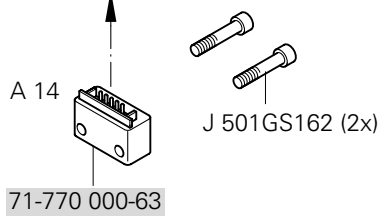

4.03

Einbaumotor
Built-in motor
Motor incorporado
内装式电机

PFAFF 3371-1/..

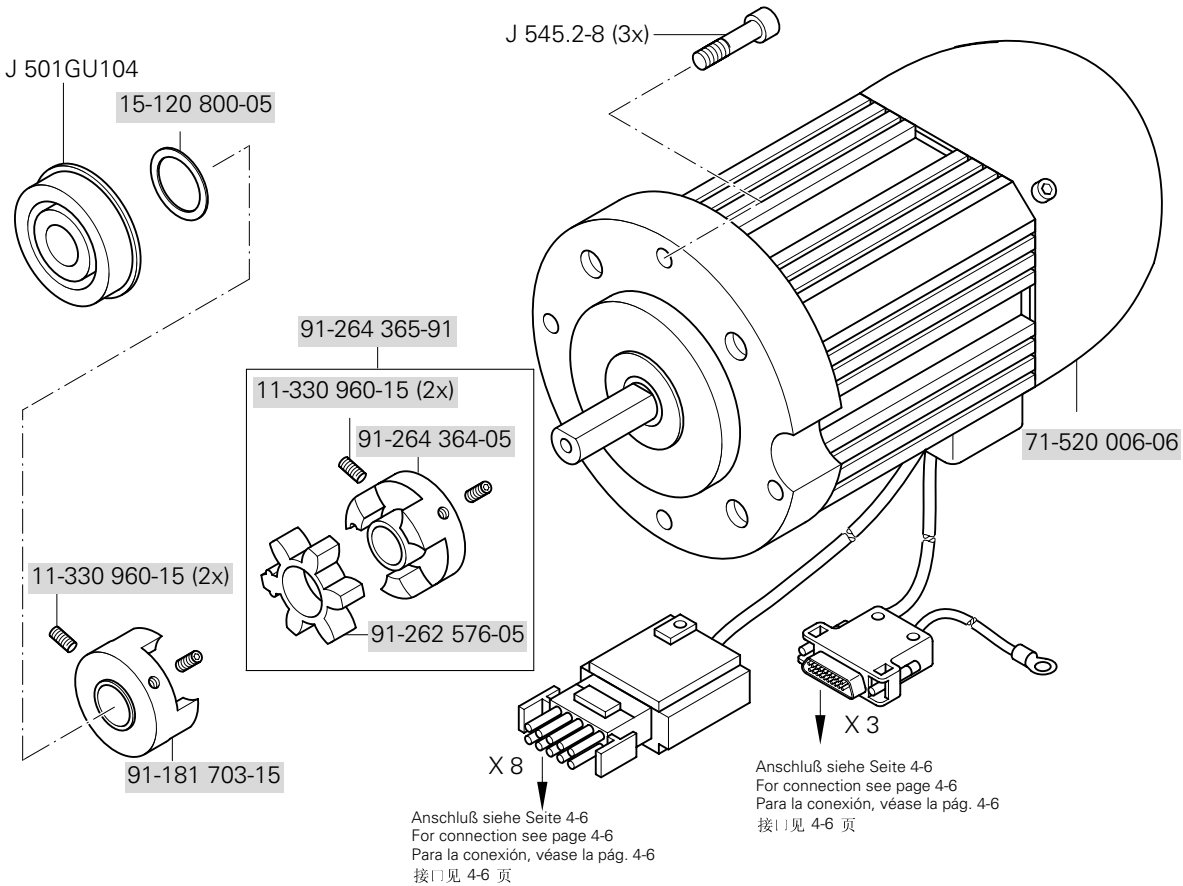
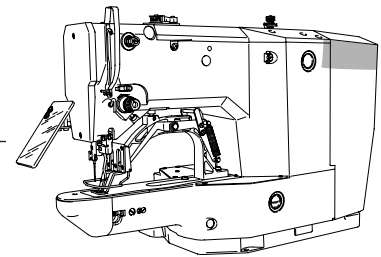

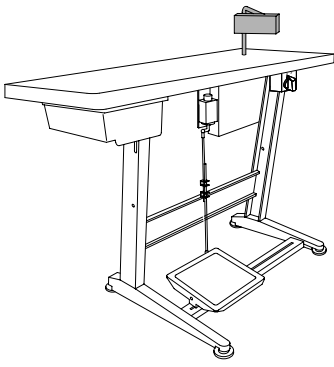

Bedienfeld
Control panel
Panel de mandos
操作板

PFAFF 3371-1/..

4.04

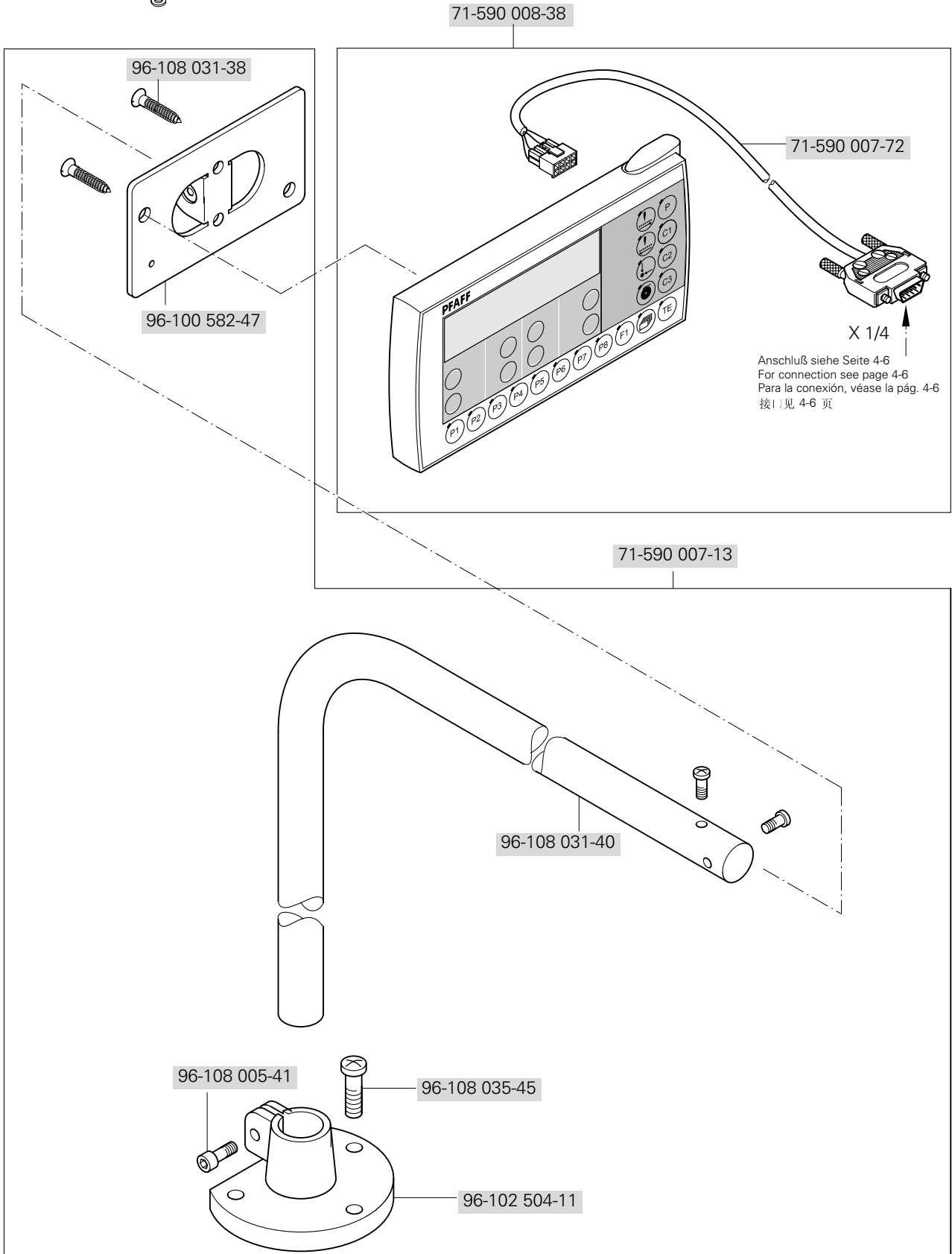

siehe Kapitel 2 Erläuterung der Schlüsselzeichen
 see chapter 2 Explanation of key markings
 véase el Cap. 2 Explicaciones de los signos clave
 见第2章标记说明

= als Ersatzteil lieferbar
 = available as spar part
 = para entregar como repuesto
 = 可以作为备件供货

4.05

Sollwertgeber
Set-point generator
Emisor del valor teórico
给定值发生器

PFAFF 3371-1/..

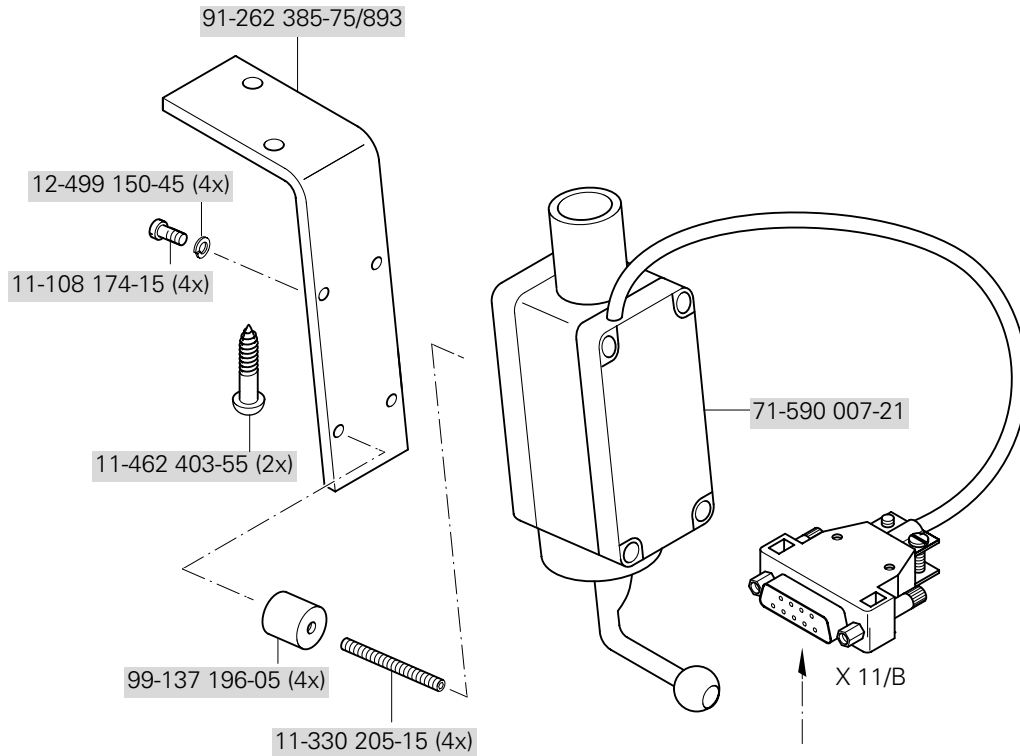
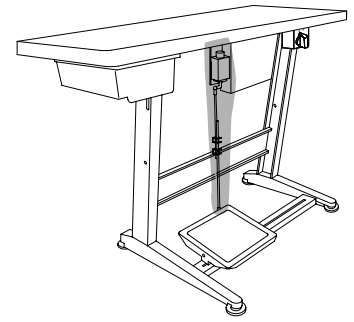

Anschluß siehe Seite 4-6
For connection see page 4-6
Para la conexión, véase la pág. 4-6
接口见 4-6 页

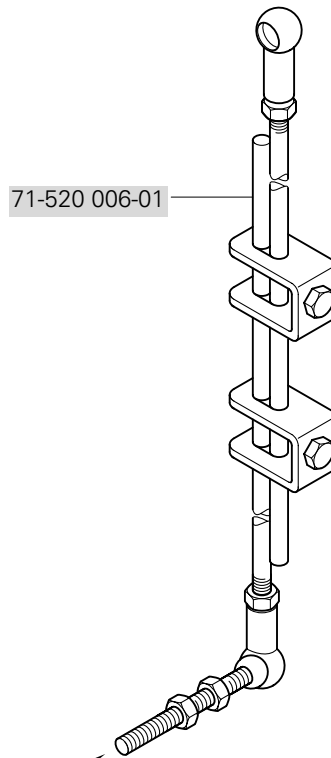

Zur Tretplatte
For the pedal
Para el pedal
压于踏板

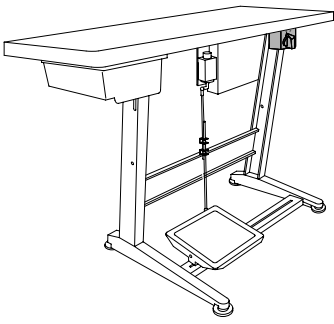

Motor-Hauptschalter
 Main switch
 Interruptor principal
 电机主开关 PFAFF 3371-1/..

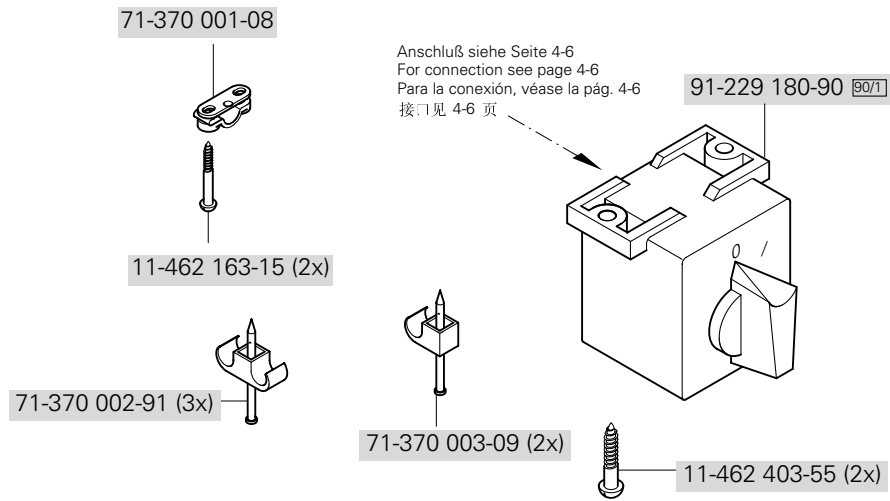

4.07

Steuerkasten Control box Caja de mandos 控制箱

PFAFF 3371-1/..

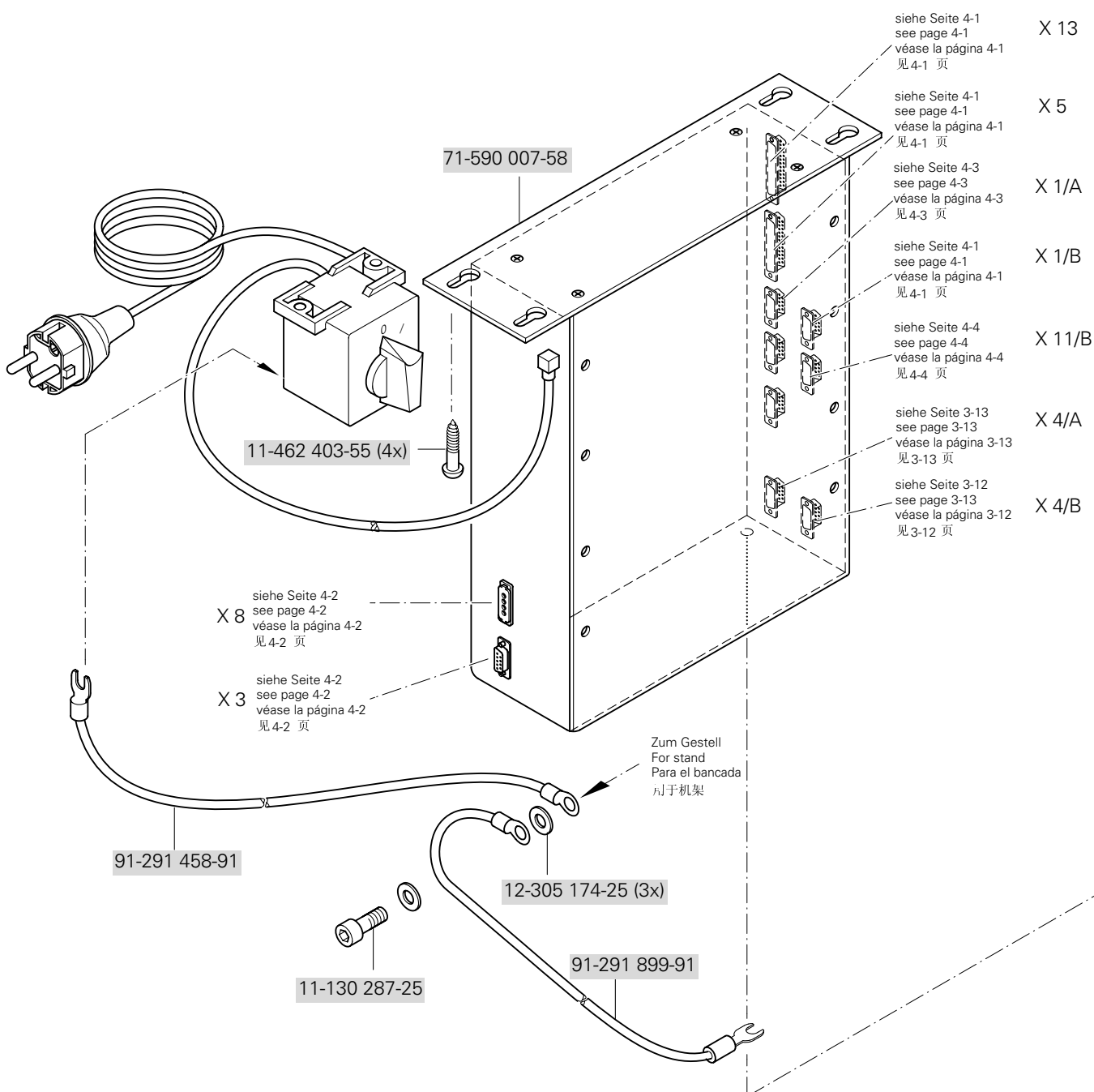
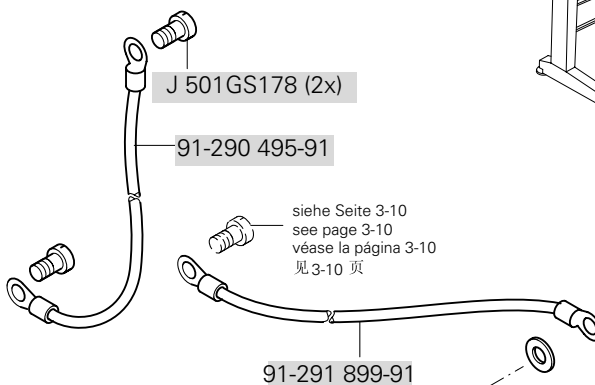
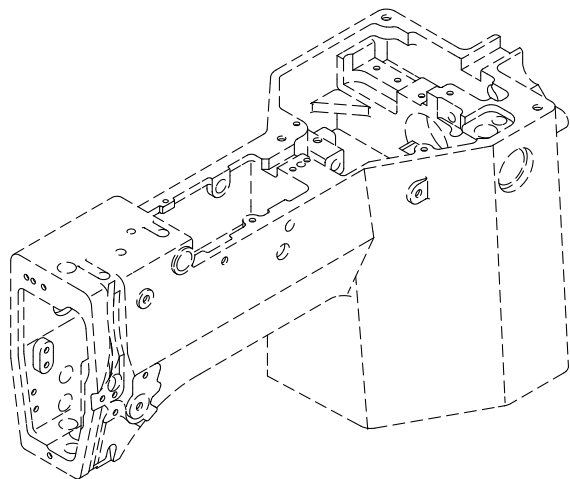
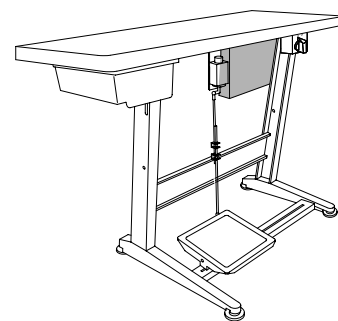

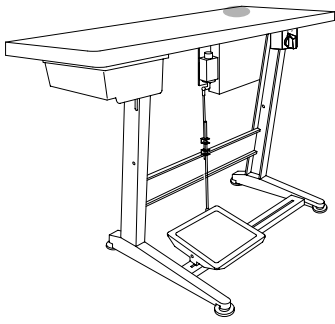



Garnrollenständer
 Reel stands
 Portacarretes
 线轴支架

PFAFF 3371-1/..

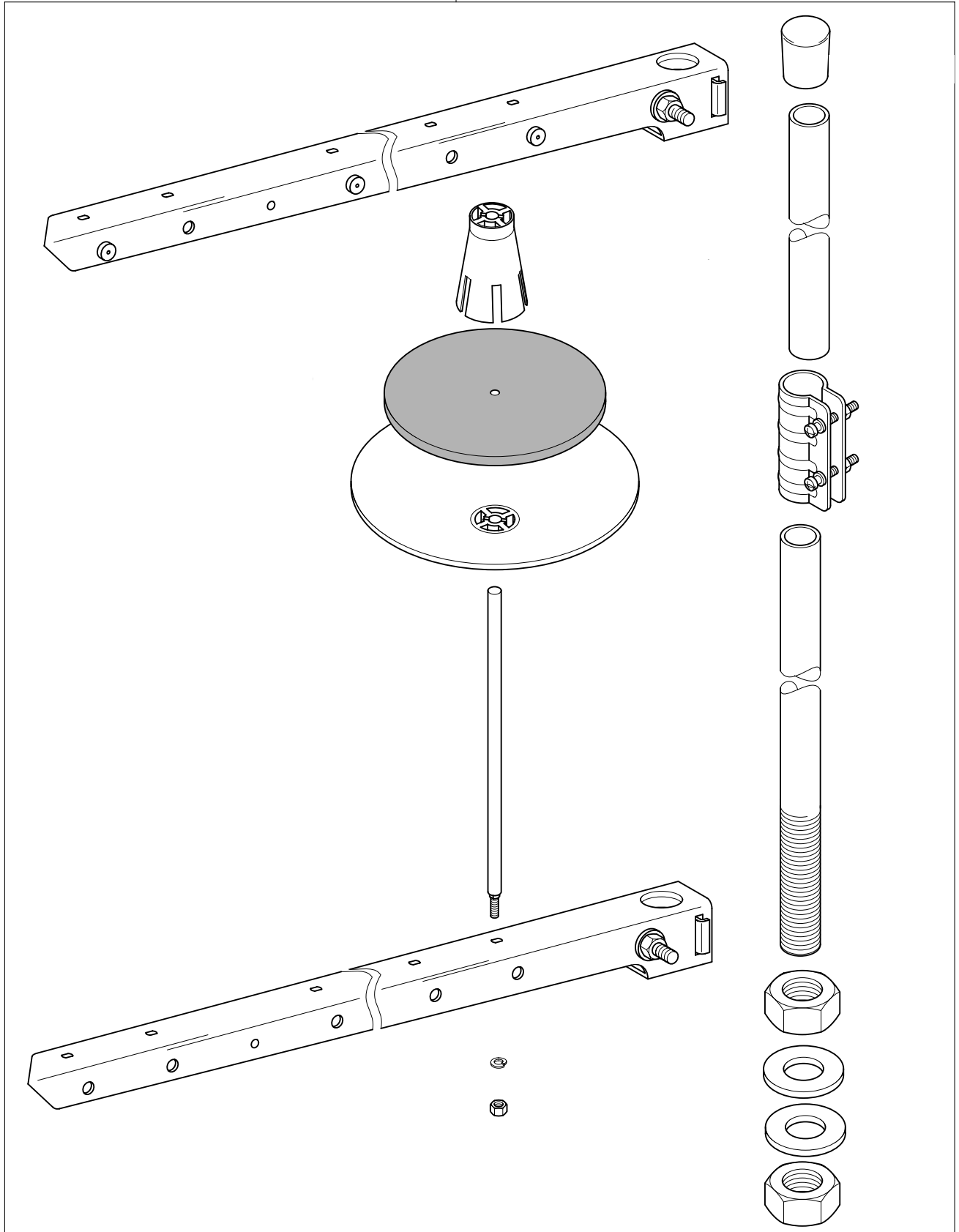
91-229 070-70/895



 siehe Kapitel 2 Erläuterung der Schlüsselzeichen
 see chapter 2 Explanation of key markings
 véase el Cap. 2 Explicaciones de los signos clave
 见第2章标记说明

 = als Ersatzteil lieferbar
 = available as spar part
 = para entregar como repuesto
 = 可以作为备件供货

6

Schmiermittel-Übersicht

Overview of lubricants

Tabla de lubricantes

润滑剂一览

PFAFF 3371-1/..

Öl Oil Aceite 油	Mittelpunkts-Viskosität bei: Mean viscosity at: Viscosidad media a: 中点粘度:		Dichte bei: Density of: Densidad a: 密度, 在:		Bestellnummer für Behälter mit: Part number for can with: Número de pedido para recipientes con: 订货号用于油箱, 带:		
	°C	mm ² /s	°C	g/cm ³ (g/ml)	1 Liter 1 Litre 1 Litro 1 升	5 Liter 5 Litre 5 Litros 5 升	10 Liter 10 Litre 10 Litros 10 升
28-011 201-05	40	10,0	15	0,847	91-027 975-91		

Fett Grease Grasa 脂	Penetration Penetration Penetración 贯入度	Tropfpunkt Drip-point Punto de goteo 滴点	Bestellnummer für Behälter mit: Part number for can with: Número de pedido para recipientes con: 订货号用于油箱, 带:				
			mm/10	°C	0,25 kg	0,5 kg	1 kg

Reinigungsmittel Cleansing agent Limpiadores 清洁剂	Bestellnummer für Behälter mit: Part number for can with: Número de pedido para recipientes con: 订货号用于油箱, 带:
Isopropyl-Alkohol 异丙醇	240 ml 95-665 735-91

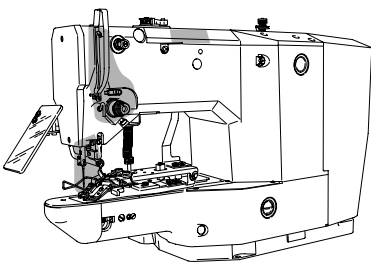

Abweichende Teile der PFAFF 3371-10/..
 Different parts for PFAFF 3371-10/..
 Piezas de la PFAFF 3371-10/.. que son diferentes
 PFAFF 3371-10/.. 中有差别的零件

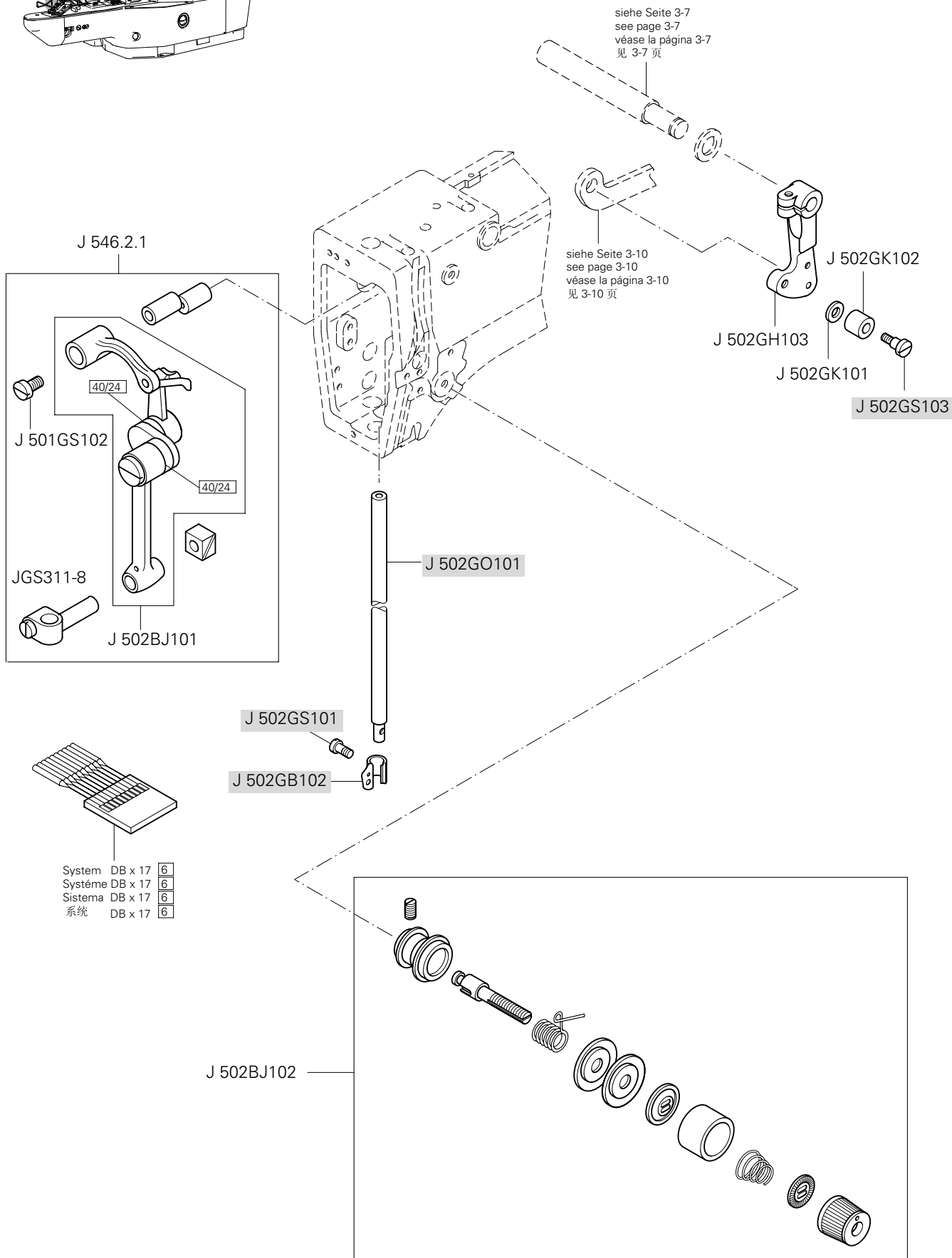

siehe Kapitel 2 Erläuterung der Schlüsselzeichen
 see chapter 2 Explanation of key markings
 véase el Cap. 2 Explicaciones de los signos clave
 见第2章标记说明

(die sonstigen Teile wie in Register 3.01 bis 6)
 (for all other parts see Sections 3.01 to 6)
 (las demás piezas como en los registros 3.01 al 6)
 (其它零件与3.01至6 章中的相同)

= als Ersatzteil lieferbar
 = available as spare part
 = para entregar como repuesto
 = 可以作为备件供货

7

Abweichende Teile der PFAFF 3371-10/..
 Different parts for PFAFF 3371-10/..
 Piezas de la PFAFF 3371-10/.. que son diferentes
 PFAFF 3371-10/.. 中有差别的零件

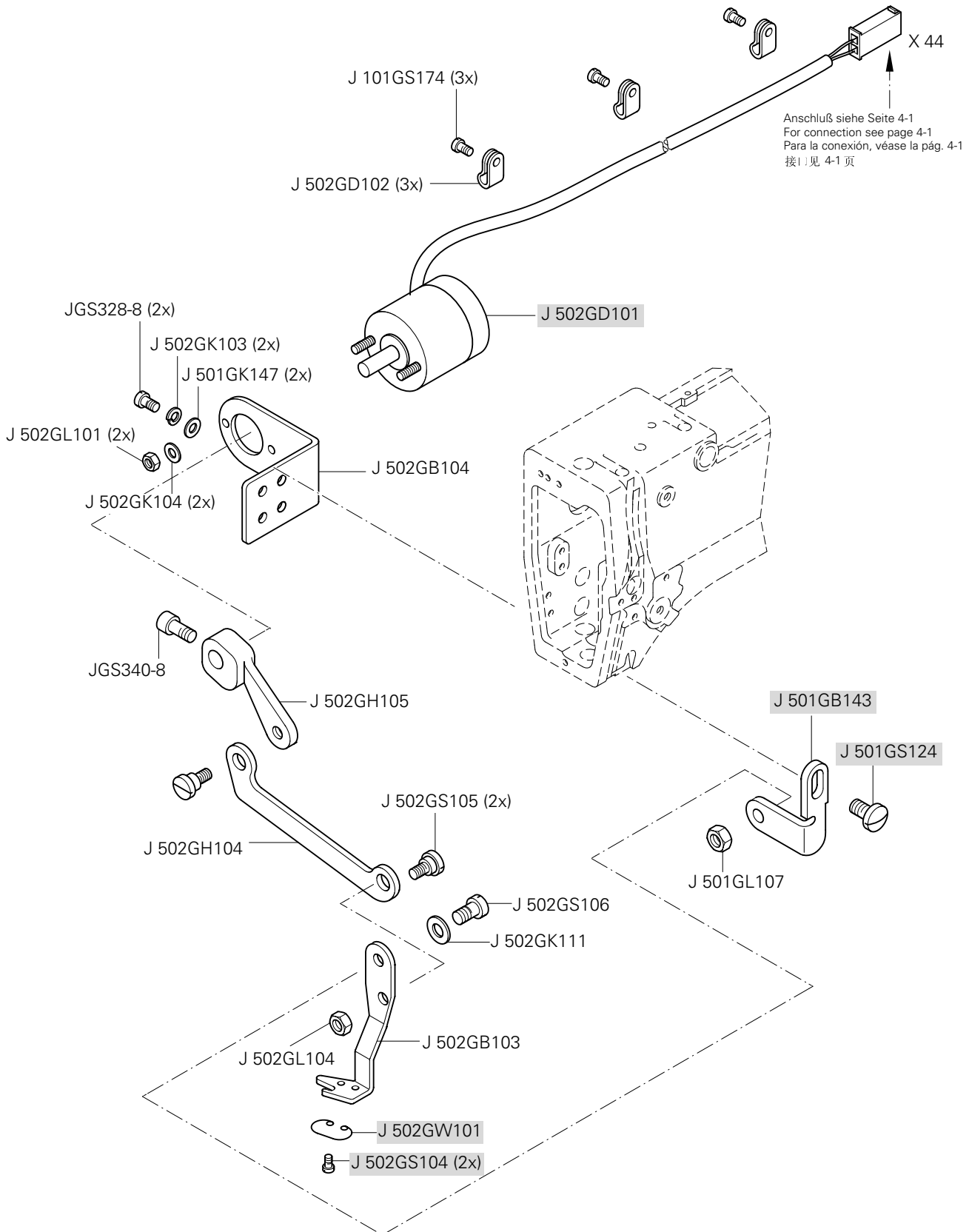
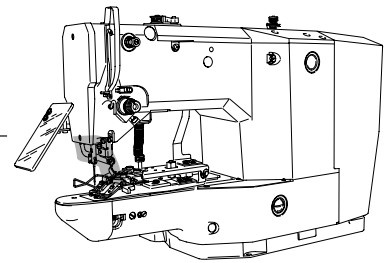

Abweichende Teile der PFAFF 3371-10/..
 Different parts for PFAFF 3371-10/..
 Piezas de la PFAFF 3371-10/.. que son diferentes
 PFAFF 3371-10/.. 中有差别的零件

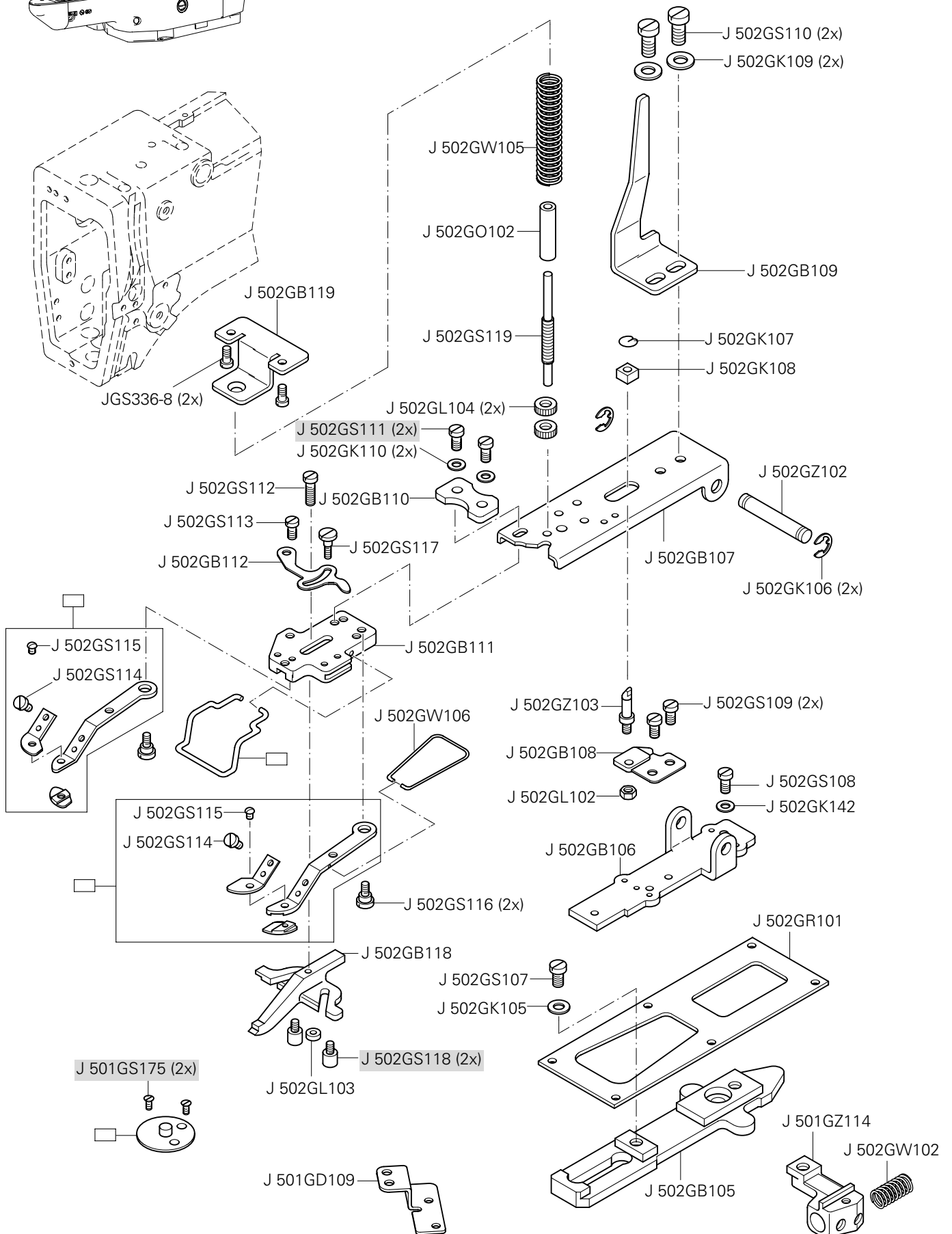
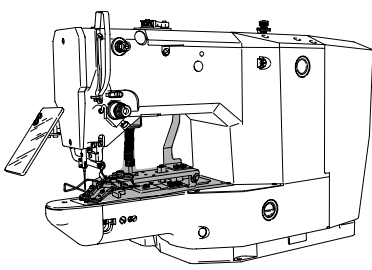

■ siehe Kapitel 2 Erläuterung der Schlüsselzeichen
 see chapter 2 Explanation of key markings
 véase el Cap. 2 Explicaciones de los signos clave
 见第2章标记说明

(die sonstigen Teile wie in Register 3.01 bis 6)
 (for all other parts see Sections 3.01 to 6)
 (las demás piezas como en los registros 3.01 al 6)
 (其它零件与3.01至6章中的相同)

■ = als Ersatzteil lieferbar
 = available as spar part
 = para entregar como repuesto
 = 可以作为备件供货

No. 零件号	Seite Page Página 页号	No. 零件号	Seite Page Página 页号	No. 零件号	Seite Page Página 页号	No. 零件号	Seite Page Página 页号
11-108 174-15	4 - 4	95-665 735-91	6 - 1	J 501GB101	3 - 1	J 501GB157	3 - 6
11-130 287-25	4 - 6	96-100 582-47	4 - 3	J 501GB102	3 - 5	J 501GB158	3 - 8
11-330 205-15	4 - 4	96-102 504-11	4 - 3	J 501GB103	3 - 5	J 501GB159	3 - 8
11-330 960-15	4 - 2	96-108 005-41	4 - 3	J 501GB104	3 - 4	J 501GB160	3 - 11
11-462 163-15	4 - 5	96-108 031-38	4 - 3	J 501GB105	3 - 4	J 501GB161	3 - 8
11-462 403-55	4 - 4, 4 - 5, 4 - 6	96-108 031-40	4 - 3	J 501GB106	3 - 4	J 501GB165	3 - 13
12-305 174-25	4 - 6	96-108 035-45	4 - 3	J 501GB107	3 - 5	J 501GB166	3 - 14
12-499 150-45	4 - 4	99-137 196-05	4 - 4	J 501GB108	3 - 1	J 501GB168	3 - 3, 3 - 12
15-120 800-05	4 - 2	J 101GS174	7 - 2	J 501GB114	3 - 4	J 501GB169	3 - 12
28-011 201-05	6 - 1	J 501BJ101	3 - 5	J 501GB117	3 - 2	J 501GB170	3 - 13
71-370 001-08	4 - 5	J 501BJ103	3 - 5	J 501GB123	3 - 10	J 501GB171	3 - 12
71-370 002-91	4 - 5	J 501BJ111	3 - 12	J 501GB124	3 - 10	J 501GB172	3 - 14
71-370 003-09	4 - 5	J 501BJ112	3 - 10	J 501GB125	3 - 10	J 501GB173	3 - 14
71-520 006-01	4 - 4	J 501BJ113	3 - 10	J 501GB126	3 - 10	J 501GB174	3 - 14
71-520 006-06	4 - 2	J 501BJ114	3 - 10, 3 - 13	J 501GB127	3 - 10	J 501GB176	3 - 14
71-590 007-13	4 - 3	J 501BJ116	3 - 15	J 501GB128	3 - 10	J 501GB178	3 - 16
71-590 007-21	4 - 4	J 501BJ118	3 - 16	J 501GB129	3 - 10	J 501GB179	3 - 16
71-590 007-58	4 - 6	J 501BJ119	3 - 15	J 501GB131	3 - 16	J 501GB180	3 - 2
71-590 007-72	4 - 3	J 501BJ120	3 - 15	J 501GB132	3 - 16	J 501GB181	3 - 3
71-590 008-38	4 - 3	J 501BJ123	3 - 3	J 501GB133	3 - 15	J 501GB182	3 - 3
71-770 000-63	4 - 2	J 501BJ124	3 - 3	J 501GB134	3 - 16	J 501GB184	3 - 2
91-027 975-91	6 - 1	J 501BJ125	3 - 4	J 501GB135	3 - 16	J 501GB185	3 - 2, 3 - 16
91-181 703-15	4 - 2	J 501BJ126	3 - 4	J 501GB138	3 - 16	J 501GB186	3 - 16
91-229 070-70/8955 - 1		J 501BJ127	3 - 4	J 501GB139	3 - 16	J 501GB187	3 - 16
91-229 180-90	4 - 5	J 501BJ128	3 - 9	J 501GB142	3 - 3	J 501GB188	3 - 16
91-262 385-75/8934 - 4		J 501BJ130	3 - 9	J 501GB143	3 - 3, 7 - 2	J 501GB189	3 - 8
91-262 576-05	4 - 2	J 501BJ131	3 - 11	J 501GB146	3 - 7	J 501GB190	3 - 8
91-264 364-05	4 - 2	J 501BJ132	3 - 11	J 501GB147	3 - 4	J 501GB191	3 - 8
91-264 365-91	4 - 2	J 501BJ133	3 - 11	J 501GB148	3 - 4	J 501GB192	3 - 8
91-290 495-91	4 - 6	J 501BJ135	3 - 14	J 501GB149	3 - 7	J 501GB193	3 - 6
91-291 458-91	4 - 6	J 501BJ139	3 - 8, 3 - 16	J 501GB150	3 - 7	J 501GB194	3 - 6
91-291 899-91	4 - 6	J 501BJ146	3 - 15	J 501GB155	3 - 9	J 501GB196	3 - 2
91-292 080-91	4 - 1	J 501G7113	3 - 7	J 501GB156	3 - 8	J 501GB197	3 - 2

No. 零件号	Seite Page Página 页号	No. 零件号	Seite Page Página 页号	No. 零件号	Seite Page Página 页号	No. 零件号	Seite Page Página 页号
J 501GB199	3 - 2	J 501GH108	3 - 10	J 501GK137	3 - 11, 3 - 16	J 501GO111	3 - 13
J 501GB200	3 - 2	J 501GH109	3 - 7	J 501GK138	3 - 11	J 501GP102	3 - 6
J 501GB202	3 - 2	J 501GH110	3 - 7	J 501GK139	3 - 11	J 501GP103	3 - 6
J 501GB208	3 - 1	J 501GH111	3 - 7	J 501GK141	3 - 8	J 501GR101	3 - 1
J 501GB209	3 - 1	J 501GH112	3 - 7	J 501GK142	3 - 12, 3 - 14	J 501GR102	3 - 1
J 501GC101	3 - 6	J 501GH114	3 - 3	J 501GK143	3 - 13	J 501GR103	3 - 1
J 501GC102	3 - 6	J 501GH115	3 - 7	J 501GK144	3 - 14	J 501GR104	3 - 1
J 501GC103	3 - 15	J 501GH116	3 - 9	J 501GK145	3 - 14	J 501GR105	3 - 1
J 501GC105	3 - 12	J 501GH117	3 - 11	J 501GK147	3 - 1, 7 - 2	J 501GR109	3 - 3
J 501GC106	3 - 12	J 501GH118	3 - 11	J 501GL101	3 - 4	J 501GR110	3 - 12
J 501GC107	3 - 13	J 501GH119	3 - 11	J 501GL102	3 - 1	J 501GS58	3 - 4
J 501GD103	3 - 13	J 501GK101	3 - 1	J 501GL105	3 - 7, 3 - 9	J 501GS101	3 - 5
J 501GD106	3 - 12	J 501GK106	3 - 1	J 501GL106	3 - 15	J 501GS102	3 - 1, 3 - 5, 7 - 1
J 501GD107	3 - 13	J 501GK107	3 - 3	J 501GL107	3 - 7, 3 - 11, 7 - 2	J 501GS103	3 - 1, 3 - 4, 3 - 10, 3 - 12
J 501GD108	3 - 12	J 501GK108	3 - 6	J 501GL109	3 - 9	J 501GS104	3 - 1
J 501GD109	3 - 13, 7 - 3	J 501GK113	3 - 10	J 501GL110	3 - 11	J 501GS105	3 - 1
J 501GD110	3 - 12	J 501GK114	3 - 10	J 501GL114	3 - 8	J 501GS106	3 - 1
J 501GD130	3 - 10	J 501GK121	3 - 15	J 501GM101	3 - 11	J 501GS107	3 - 1
J 501GF101	3 - 1	J 501GK122	3 - 15	J 501GN101	3 - 15	J 501GS108	3 - 1, 3 - 5, 3 - 12, 3 - 13
J 501GF102	3 - 1	J 501GK123	3 - 15	J 501GN102	3 - 15	J 501GS112	3 - 2
J 501GF103	3 - 1	J 501GK124	3 - 15	J 501GN103	3 - 15	J 501GS113	3 - 2
J 501GF104	3 - 1	J 501GK125	3 - 15	J 501GN104	3 - 15	J 501GS114	3 - 3
J 501GF105	3 - 1	J 501GK126	3 - 15	J 501GN105	3 - 15	J 501GS115	3 - 3
J 501GF106	3 - 1	J 501GK127	3 - 15	J 501GN107	3 - 1	J 501GS116	3 - 3
J 501GF107	3 - 1	J 501GK128	3 - 15	J 501GN111	3 - 15	J 501GS117	3 - 3
J 501GF108	3 - 1	J 501GK129	3 - 3	J 501GO101	3 - 2	J 501GS118	3 - 3, 3 - 6, 3 - 15
J 501GF109	3 - 1	J 501GK130	3 - 3	J 501GO102	3 - 2	J 501GS119	3 - 6
J 501GF114	3 - 12, 3 - 13	J 501GK131	3 - 7	J 501GO103	3 - 2	J 501GS120	3 - 6
J 501GF115	3 - 13	J 501GK132	3 - 9	J 501GO105	3 - 3	J 501GS121	3 - 6
J 501GF118	3 - 5	J 501GK133	3 - 9	J 501GO106	3 - 6	J 501GS122	3 - 12, 3 - 13
J 501GH104	3 - 3	J 501GK134	3 - 9	J 501GO107	3 - 15	J 501GS124	3 - 3, 3 - 4, 3 - 10, 7 - 2
J 501GH106	3 - 10	J 501GK135	3 - 8	J 501GO108	3 - 15	J 501GS128	3 - 10
J 501GH107	3 - 10	J 501GK136	3 - 8	J 501GO109	3 - 11	J 501GS129	3 - 10

No. 零件号	Seite Page Página 页号	No. 零件号	Seite Page Página 页号	No. 零件号	Seite Page Página 页号	No. 零件号	Seite Page Página 页号
J 501GS130	3 - 9, 3 - 10, 3 - 15	J 501GS169	3 - 11	J 501GW111	3 - 3	J 502GB106	7 - 3
J 501GS131	3 - 9, 3 - 10	J 501GS170	3 - 11	J 501GW112	3 - 7	J 502GB107	7 - 3
J 501GS132	3 - 10	J 501GS171	3 - 11	J 501GW113	3 - 4	J 502GB108	7 - 3
J 501GS133	3 - 10	J 501GS172	3 - 11	J 501GW114	3 - 4	J 502GB109	7 - 3
J 501GS134	3 - 7	J 501GS173	3 - 11	J 501GW115	3 - 9	J 502GB110	7 - 3
J 501GS135	3 - 10	J 501GS174	3 - 11	J 501GW116	3 - 11	J 502GB111	7 - 3
J 501GS136	3 - 7	J 501GS175	3 - 11, 7 - 3	J 501GW118	3 - 8	J 502GB112	7 - 3
J 501GS137	3 - 7, 3 - 14	J 501GS177	3 - 8	J 501GW119	3 - 14	J 502GB118	7 - 3
J 501GS139	3 - 15	J 501GS178	3 - 1, 3 - 2, 3 - 8, 3 - 12, 3 - 13, 3 - 16, 4 - 6	J 501GX101	3 - 1	J 502GB119	7 - 3
J 501GS140	3 - 15			J 501GX104	3 - 6	J 502GD101	7 - 2
J 501GS141	3 - 6	J 501GS179	3 - 12	J 501GX105	3 - 10	J 502GD102	7 - 2
J 501GS142	3 - 15	J 501GS180	3 - 12	J 501GX106	3 - 15	J 502GH103	7 - 1
J 501GS143	3 - 1	J 501GS181	3 - 12	J 501GX109	3 - 1	J 502GH104	7 - 2
J 501GS144	3 - 12, 3 - 15	J 501GS182	3 - 14	J 501GX112	3 - 4	J 502GH105	7 - 2
J 501GS145	3 - 15	J 501GS183	3 - 3	J 501GX113	3 - 9	J 502GK101	7 - 1
J 501GS146	3 - 15, 3 - 16	J 501GS184	3 - 12	J 501GZ104	3 - 6	J 502GK102	7 - 1
J 501GS147	3 - 15	J 501GS185	3 - 13	J 501GZ106	3 - 10	J 502GK103	7 - 2
J 501GS149	3 - 3	J 501GS186	3 - 13	J 501GZ107	3 - 10	J 502GK104	7 - 2
J 501GS150	3 - 3	J 501GS187	3 - 13	J 501GZ108	3 - 7	J 502GK105	7 - 3
J 501GS151	3 - 3, 3 - 4	J 501GS188	3 - 14	J 501GZ110	3 - 15	J 502GK106	7 - 3
J 501GS152	3 - 7	J 501GS189	3 - 2	J 501GZ113	3 - 9	J 502GK107	7 - 3
J 501GS153	3 - 7	J 501GS193	3 - 11	J 501GZ114	3 - 13, 7 - 3	J 502GK108	7 - 3
J 501GS154	3 - 7	J 501GT101	3 - 6	J 501GZ115	3 - 12	J 502GK109	7 - 3
J 501GS155	3 - 7	J 501GU101	3 - 12	J 501GZ116	3 - 14	J 502GK110	7 - 3
J 501GS156	3 - 7	J 501GU102	3 - 15	J 501GZ117	3 - 12	J 502GK111	7 - 2
J 501GS157	3 - 7	J 501GU104	4 - 2	J 501GZ118	3 - 14	J 502GK142	7 - 3
J 501GS161	3 - 9	J 501GU108	3 - 9	J 501GZ119	3 - 14	J 502GL101	7 - 2
J 501GS162	3 - 8, 4 - 2	J 501GW105	3 - 6	J 502BJ101	7 - 1	J 502GL102	7 - 3
J 501GS163	3 - 6	J 501GW106	3 - 10	J 502BJ102	3 - 4, 7 - 1	J 502GL103	7 - 3
J 501GS164	3 - 8	J 501GW107	3 - 15	J 502GB102	3 - 2, 7 - 1	J 502GL104	7 - 2, 7 - 3
J 501GS165	3 - 9, 3 - 11	J 501GW108	3 - 1	J 502GB103	7 - 2	J 502GO101	3 - 2, 7 - 1
J 501GS166	3 - 11	J 501GW109	3 - 15	J 502GB104	7 - 2	J 502GO102	7 - 3
J 501GS168	3 - 11	J 501GW110	3 - 1	J 502GB105	7 - 3	J 502GR101	7 - 3

No. 零件号	Seite Page Página 页号	No. 零件号	Seite Page Página 页号	No. 零件号	Seite Page Página 页号	No. 零件号	Seite Page Página 页号
J 502GS101	3 - 2, 7 - 1	J 546.2.1	7 - 1				
J 502GS103	7 - 1	JGL 216-8	3 - 9, 3 - 11				
J 502GS104	7 - 2	JGR 603-8	3 - 4				
J 502GS105	7 - 2	JGR 683-8	3 - 1				
J 502GS106	7 - 2	JGS 311-8	3 - 3, 7 - 1				
J 502GS107	7 - 3	JGS 328-8	7 - 2				
J 502GS108	7 - 3	JGS 336-8	7 - 3				
J 502GS109	7 - 3	JGS 340-8	7 - 2				
J 502GS110	7 - 3	JGS 380-8	3 - 14				
J 502GS111	7 - 3	JGS 540-8	3 - 8, 3 - 11, 3 - 14				
J 502GS112	7 - 3	JGS 619-8	3 - 15				
J 502GS113	7 - 3	JSS-4090540	3 - 4				
J 502GS114	7 - 3	JSS-716040	3 - 6				
J 502GS115	7 - 3						
J 502GS116	7 - 3						
J 502GS117	7 - 3						
J 502GS118	7 - 3						
J 502GS119	7 - 3						
J 502GW101	7 - 2						
J 502GW102	7 - 3						
J 502GW105	7 - 3						
J 502GZ102	7 - 3						
J 502GZ103	7 - 3						
J 545BJ101	3 - 3						
J 545BJ131	3 - 1						
J 545BJ401	3 - 6						
J 545BJ701	3 - 8						
J 545GE101	4 - 1						
J 545GE102	4 - 1						
J 545GF201	3 - 1						
J 545GR102	3 - 1						
J 545GR103	3 - 1						
J 545.2-8	4 - 2						









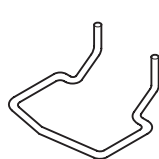

3371^{-1/..}
^{-10/..}

UNTERKLASSEN-AUSSTATTUNG

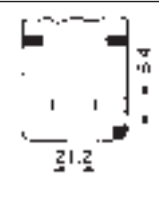
SUBCLASS PARTS

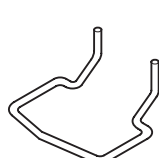
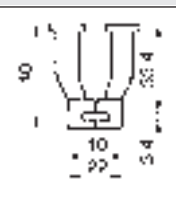
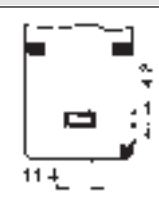
COMPOSICIÓN DE LAS SUBCLASES

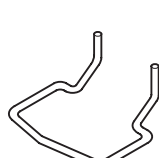
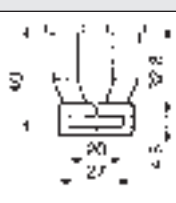
子机型-设备

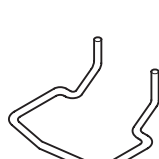
Unterklasse Subclass 子机型	Verwendungszweck Applications Fin de empleo 使用目的	Klammerfuß Work clamp foot Pinza-prensatelas 夹脚	Auflageplatte Feed plate Placa de apoyo 垫板	Stichplatteneinsatz Needle plate insert Suplemento de la placa de aguja 针板部件	Fingerschutz Finger guard Protector de dedos 护指器	Teilesatz komplett Complete parts set Juego de organos de costura 成套组件
-1 /01 Teile-Nr. Part No. Nº de pieza 零件号	Standard Material Standard material Material estandard 标准缝料	 J 501 GM 103 ① J 501 GM 104 ②	 J 501 GM 117	 J 501 GM 102	 J 501 GM 175	91-181 716-90
-1 /11 Teile-Nr. Part No. Nº de pieza 零件号	Schweres Material Heavy material Material pesado 厚缝料	 J 501 GM 105 ① J 501 GM 106 ②	 J 501 GM 120	 J 501 GM 321	 J 501 GM 175	91-181 718-90
-1 /21 Teile-Nr. Part No. Nº de pieza 零件号	Wirkware Knitting material Tejido de punto 针织品	 J 501 GM 107 ① J 501 GM 108 ②	 J 501 GM 121	 J 501 GM 102	 J 501 GM 175	91-181 719-90
-1 /31 Teile-Nr. Part No. Nº de pieza 零件号	Dünnes Material Thin material Material fino 薄缝料	 J 501 GM 103 ① J 501 GM 104 ②	 J 501 GM 119	 J 501 GM 102	 J 501 GM 175	91-181 723-90

Unterklasse Subclass Subclase 子机型	Verwendungszweck Applications Fin de empleo 使用目的	Klammerfuß Work clamp foot Pinza-prensateles 夹脚	Auflageplatte Feed plate Placa de apoyo 垫板	Stichplatteneinsatz Needle plate insert Suplemento de la placa de aguja 针板部件	Fingerschutz Finger guard Protector de dedos 护指器	Teilesatz komplett Complete parts set Juego de organos de costura 成套组件
Option Optional Opcional 选项	Standard Material Standard material Material estandard 标准缝料					J 501 GM 111 ❶ J 501 GM 112 ❷ J 501 GM 124 J 501 GM 102 J 501 GM 175 91-181 724-90
Option Optional Opcional 选项	Schweres Material Heavy material Material pesado 厚缝料					J 501 GM 109 ❶ J 501 GM 110 ❷ J 501 GM 123 J 501 GM 321 J 501 GB 210 91-181 717-90
Option Optional Opcional 选项	Schweres Material Heavy material Material pesado 厚缝料					J 501 GM 113 ❶ J 501 GM 114 ❷ J 501 GM 126 J 501 GM 321 J 501 GB 211 91-181 725-90
Option Optional Opcional 选项	Dünnes Material Thin material Material fino 薄缝料					J 501 GM 113 ❶ J 501 GM 114 ❷ J 501 GM 125 J 501 GM 102 J 501 GB 211 91-181 720-90

/ * siehe Kapitel 2 Erläuterung der Schlüsselzeichen
see chapter 2 Explanation of key markings
véase el Cap. 2 Explicaciones de los signos clave
见第2章标记说明

= als Ersatzteil lieferbar
= available as spar part
= para entregar como repuesto
= 可以作为备件供货

❶ Links
Left
Izquierda
左







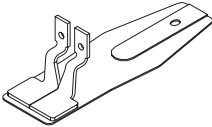

❷ Rechts
Right
Derecha
右

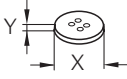
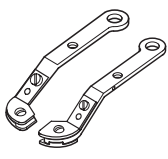
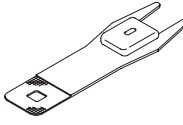
9.01

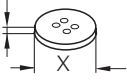
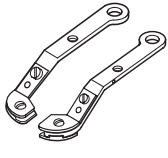
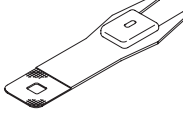
Nähwerkzeuge[▲]
 Gauge parts
 Organos de costura
 缝纫工具

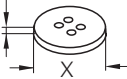
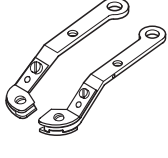
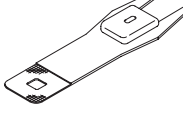
PFAFF 3371-1/..

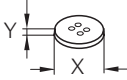
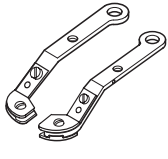
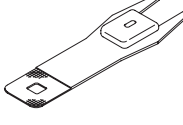
Unterklasse Subclass Subclase 子机型	Verwendungszweck Applications Fin de empleo 使用目的	Klammerfuß Work clamp foot Pinza-prensatelas 夹脚	Auflageplatte Feed plate Placa de apoyo 垫板	Teilesatz komplett Complete parts set Juego de organos de costura 成套组件		
Option Optional Opcional 选项 Teile-Nr. Part No. N° de pieza 零件号	Halbfertige Teile Semi-finished parts Piezas semiacabadas 半成品			91-181 714-90		

Unterklasse Subclass Subclase 子机型	Verwendungszweck Applications Fin de empleo 使用目的	Klammerfuß Work clamp foot Pinza-prensateles 夹脚	Auflageplatte Feed plate Placa de apoyo 垫板	Stichplatteneinsatz Needle plate insert Suplemento de la placa de aguja 针板部件	Fingerschutz Finger guard Protector de dedos 护指器	Teilesatz komplett Complete parts set Juego de organos de costura 成套组件
-10 /01	kleine Knöpfe small-size buttons botones pequeños 小钮扣 					91-181 721-90
Teile-Nr. Part No. Nº de pieza 零件号	X = 10 - 20 mm Y = 2,2 mm	J 502 BJ 103 ❶ J 502 BJ 104 ❷	J 502 GM 102	J 502 GM 101	J 502 GB 113	
-10 /11	mittlere Knöpfe medium-size buttons botones medianos 中钮扣 					91-181 726-90
Teile-Nr. Part No. Nº de pieza 零件号	X = 10 - 20 mm Y = 2,7 mm	J 503 BJ 101 ❶ J 503 BJ 102 ❷	J 503.8-1	J 503.7-1	J 502 GB 113	
-10 /21	große Knöpfe large-size buttons botones grandes 大钮扣 					91-181 727-90
Teile-Nr. Part No. Nº de pieza 零件号	X = 15 - 32 mm Y = 2,7 mm	J 504 BJ 101 ❶ J 504 BJ 102 ❷	J 504.8-1	J 504.7-1	J 502 GB 113	
-10 /31	extra kleine Knöpfe extra small buttons botones muy pequeños 特小钮扣 					91-181 728-90
Teile-Nr. Part No. Nº de pieza 零件号	X = 8 - 15 mm Y = 2,2 mm	J 505 BJ 101 ❶ J 505 BJ 102 ❷	J 502 GM 102	J 505.7-1	J 502 GB 113	

 / * siehe Kapitel 2 Erläuterung der Schlüsselzeichen
see chapter 2 Explanation of key markings
véase el Cap. 2 Explicaciones de los signos clave
见第2章标记说明

 = als Ersatzteil lieferbar
= available as spar part
= para entregar como repuesto
= 可以作为备件供货

❶ Links
Left
Izquierda
左

❷ Rechts
Right
Derecha
右



Europäische Union
Wachstum durch Innovation – EFRE



PFAFF Industriesysteme und Maschinen AG

Hans-Geiger-Str. 12 - IG Nord
D-67661 Kaiserslautern

Telefon: +49 - 631 200-0
Telefax: +49 - 631 17202
E-mail: info@pfaff-industrial.com

Hotlines:

Technischer Service / Technical service: +49 - 175 2243-101

Nähtechnik-Fachberatung / Application consultancy: +49 - 175 2243-102

Ersatzteile-Hotline / Spare-parts hotline: +49 - 175 2243-103

3371-1/..

TEILELISTE

PARTS LIST

LISTA DE PIEZAS

零件表

Diese Teileliste hat für Maschinen ab nachfolgender Seriennummer Gültigkeit:

This parts list applies to machines from the following serial numbers onwards:

Esta liste de piezas tiene validez para máquinas a partir del número de serie siguiente:

本零件表对从下列系列号起的机器有效:

2 780 933 →

Alle Informationen und Abbildungen waren zum Zeitpunkt der Druckgebung auf dem neuesten Stand.

Technische Änderungen vorbehalten!

Der Nachdruck, die Vervielfältigung sowie die Übersetzung - auch auszugsweise - aus PFAFF-Teilelisten ist nur mit unserer vorherigen Zustimmung und mit der Quellenangabe gestattet.

At the time of printing, all information and illustrations contained in this document were up to date.

Subject to alteration!

The reprinting, copying or translation of PFAFF Parts lists whether in whole or in part, is only permitted with our previous permission and with written reference to the source.

Todas las informaciones e ilustraciones de este manual estaban al día en el momento de entregarse para su impresión.

¡ Salvo modificaciones técnicas!

La reimpresión, reproducción y traducción - aunque sólo sea parcial - de las listas de piezas PFAFF sólo está permitida con nuestro permiso previo e indicando la fuente.

所有信息和图片在付印时都是最新的。

保留技术更改的权力！

全部或部分翻印、复制以及翻译PFAFF-零件表
必须事先经由我们同意并且注明来源

**PFAFF Industriesysteme
und Maschinen AG**

Hans-Geiger-Str. 12 - IG Nord

D-67661 Kaiserslautern

	Seite Page Página 页号
0 Wichtiger Hinweis	5
Important note	
Observación importante	
重要提示	
1 Basismaschine	
Basic machine	
Máquina básicas	
基础机器	
1.01 Gehäuseteile	6
Housing sections	
Piezas del cárter	
机身零件	
1.02 Kopfteile	10
Needle head parts	
Piezas de la cabeza	
机头零件	
1.03 Armteile	13
Arm parts	
Piezas del brazo	
机臂零件	
1.04 Freiarmteile	18
Cylinder bed parts	
Piezas del brazo al aire	
悬臂部分的零件	
2 Elektrische Ausrüstung	
Electrical equipment	
Equipo eléctrico	
电设备	
2.01 Kabelbaum zum Oberteil	25
Cable tree to sewing head	
Mazo de cables para el cabezal	
上部机器电缆束	
2.02 Oberteilerkennung	27
Sewing head identification	
Detección de la parte superior	
机头识别	
2.03 Einbaumotor	27
Built-in motor	
Motor incorporado	
内装式电机	

	Seite Page Página 页号
2.04 Bedienfeld	28
Control panel Panel de mandos 操作板	
2.05 Sollwertgeber	29
Set-point generator Emisor del valor teórico 给定值发生器	
2.06 Motor-Hauptschalter	30
Main switch Interruptor principal 电机主开关	
2.07 Steuerkasten	31
Control box Caja de mandos 控制箱	
3 Garnrollenständer	32
Reel stands Portacarretes 线轴支架	
4 Schmiermittel-Übersicht	33
Overview of lubricants Tabla de lubricantes 润滑剂一览	
5 Index (Teilenummern / Seitenzahlen)	34
Index (part numbers / page numbers) Index (números de pieza / números de página) 注脚(零件号/页号)	
6 Unterklassen-Ausstattung	
Subclass parts Composición de las subclases 子机型-设备	
6.01 Nähwerkzeuge (PFAFF 3371-1/..)	40
Gauge parts (PFAFF 3371-1/..) Organos de costura (PFAFF 3371-1/..) 缝纫工具 (PFAFF 3371-1/..)	

Achtung!



Wir machen ausdrücklich darauf aufmerksam, daß Ersatz- und Zubehörteile, die nicht von uns geliefert werden, auch nicht von uns geprüft und freigegeben sind. Der Einbau und / oder die Verwendung solcher Produkte kann daher u. Umständen konstruktiv vorgegebene Eigenschaften Ihrer Maschine negativ verändern. Für Schäden, die durch die Verwendung von Nicht-Originalteilen entstehen, übernehmen wir keine Haftung!

Caution!



We warn you expressively that spare parts and accessories that are not supplied by us are not tested and released by us. Fitting or using these products may therefore have negative influences on features that depend on the machine design. We are not liable for any damage caused by the use of non-Pfaff parts!

¡Atención!



Se hace observar que en el caso de piezas de recambio y accesorios que no hayan sido suministrados por nosotros, quiere decir que non han sido sometidas por nuestra parte a un control y que no se les ha dado el visto bueno. Por esta razón, el montaje y/o empleo de tales productos puede repercutir negativamente en las características previstas en su máquina. ¡Para los daños que eventualmente pudiesen presentarse al utilizar piezas no originales, no asumimos ninguna garantía!

注意!



我们必须明确指出，所有不是由我们供货的备件和附件都未经我们检查，也没有被我们批准使用。装入和/或使用这些产品可能在一定的情况下会对机器的设计特性造成负面改变。对由于使用非原装件所造成的损失，我们不负任何责任！

1.01

Gehäuseteile
Housing sections
Piezas del cárter
机身零件

PFAFF 3371-1/..

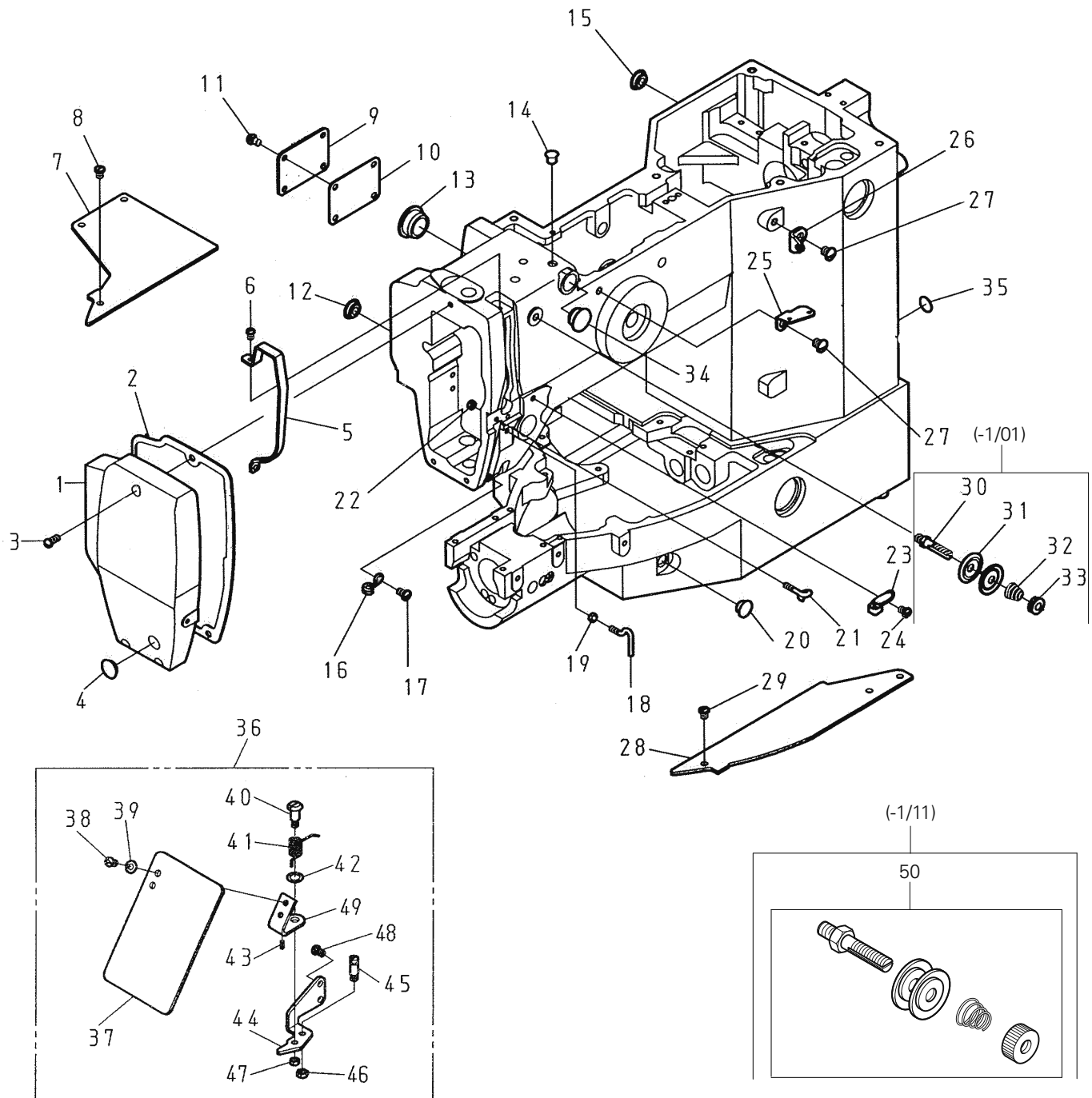

Pos.-Nr. Item No. N° de pos. 序号	Teile-Nr. Part No. N° de pieza 零件号	Menge Freq. Cantida 數量
1	W 3450111000	1
2	W 3450114800	1
3	W ZSB11028	3
4	W SEN1205400	1
5	W PC1083-0A	1
6	W ZSB09020	2
7	W 3450110401	1
8	W ZSB11082	3
9	W 3450111100	1
10	W 3450114300	1
11	W ZSE11002	4
12	W SEN1250400	2
13	W PC1013-0A	3
14	W SEN0700700	1
15	W SEN1250400	2
16	W PC1055-0A	1
17	W ZSB11032	1
18	W PC1053-0A	1
19	W ZSL09001	1
20	W SEN1000500	1
21	W HB1054-0A	2
22	W ZSL09001	1
23	W 5100311600	1
24	W ZSB11082	1
25	W 3450313400	1

Pos.-Nr. Item No. N° de pos. 序号	Teile-Nr. Part No. N° de pieza 零件号	Menge Freq. Cantida 數量
26	W 3450313300	1
27	W ZSB15027	2
28	W 3450110801	1
29	W ZSB11082	2
30	W PC1026-1A	1
31	W HB1025-0A	2
32	W PC1021-1A	1
33	W ZSN16004	1
34	W SEN140700	1
35	W WARN000500	1
36	W PC7150-0A	1
37	W H7151-0A	1
38	W ZSB11029	2
39	W WA049006	2
40	W ZSG11062	1
41	W HB1088-0A	1
42	W WA060017	1
43	W YD020006	1
44	W PC7152-0A	1
45	W ZSK12028	1
46	W ZSL12004	1
47	W ZSL11007	1
48	W ZSB11029	2
49	W HB1086-0A	1
50	W PC1020-OG (-1/11)	1

1.01

Gehäuseteile
Housing sections
Piezas del cárter
机身零件

PFAFF 3371-1/..

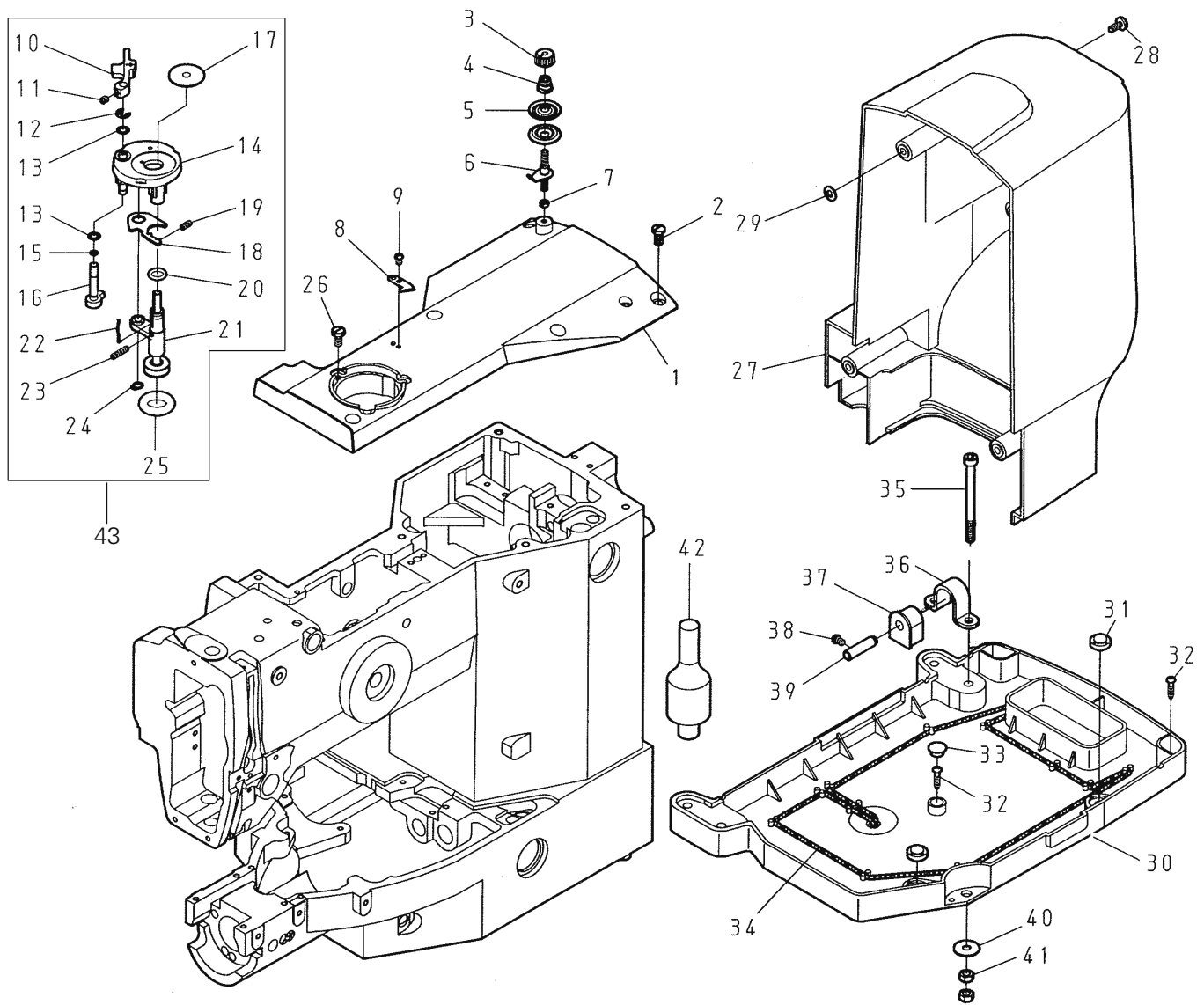

Pos.-Nr. Item No. N° de pos. 序号	Teile-Nr. Part No. N° de pieza 零件号	Menge Freq. Cantida 數量
1	W 3450110500	1
2	W ZSB15005	6
3	W 51003155TO	1
4	W 3450322900	1
5	W 5100315300	2
6	W 3450322600	1
7	W ZSL11007	1
8	W 4710320400	1
9	W ZSB09020	1
10	W 3450321100	1
11	W ZSH11004	1
12	W RE000050	1
13	W 3450322800	2
14	W 3450320104	1
15	W OPP0040100	1
16	W 3450322404	1
17	W 3450322100	1
18	W 3450321500	1
19	W 3450321800	1
20	W OPP0092270	1
21	W 3450320904	1
22	W 3450321200	1

Pos.-Nr. Item No. N° de pos. 序号	Teile-Nr. Part No. N° de pieza 零件号	Menge Freq. Cantida 數量
23	W 3450321700	1
24	W RB200060	1
25	W 3450322000	1
26	W ZSB11114	3
27	W 3450339000	1
28	W ZSB11114	4
29	W 3450336100	4
30	W 3450350100	1
31	W 3450913700	2
32	W ZMT03008	4
33	W SEN1000500	1
34	W XA301000	1
35	W ZMJ06018	4
36	W 3450911700	2
37	W 3450911500	2
38	W ZSB11029	2
39	W YA079310	2
40	W WA069005	4
41	W ZML06001	8
42	W 3450119000	1
43	W 3450320105	1

1.02

Kopfteile
Needle head parts
Piezas de la cabeza
机头零件

PFAFF 3371-1/..

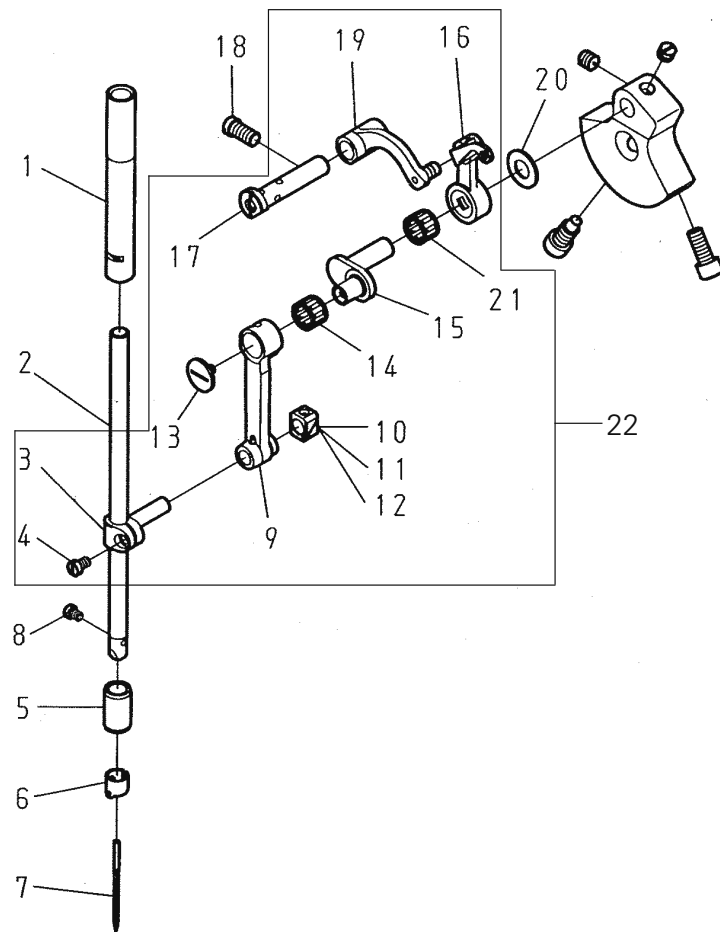

Pos.-Nr. Item No. N° de pos. 序号	Teile-Nr. Part No. N° de pieza 零件号	Menge Freq. Cantidad 數量
1	W PC1071-0A	1
2	W 3450140100	1
3	W 5100140900	1
4	W ZSB09014	1
5	W 3450140500	1
6	W 3450140700	1
7	Unterklasse Subclasse -1/01 = 134; DPx5 Subclasse -1/11 = 135x17; DPx17 子机型	1
9	W 3450121000	1
10	W 3450141010	1
11	W 3450141020	1

Pos.-Nr. Item No. N° de pos. 序号	Teile-Nr. Part No. N° de pieza 零件号	Menge Freq. Cantidad 數量
8	W ZSB08010	1
9	W 3450121000	1
10	W 3450141010	1
11	W 3450141020	1
15	W 3450121300	1
16	W PC1085-0A	1
17	W 3450190700	1
18	W ZSB15007	1
19	W PC1064-0A	1
20	W WH208002	1
21	W BNKT8128	1
22	W 3450190105	1

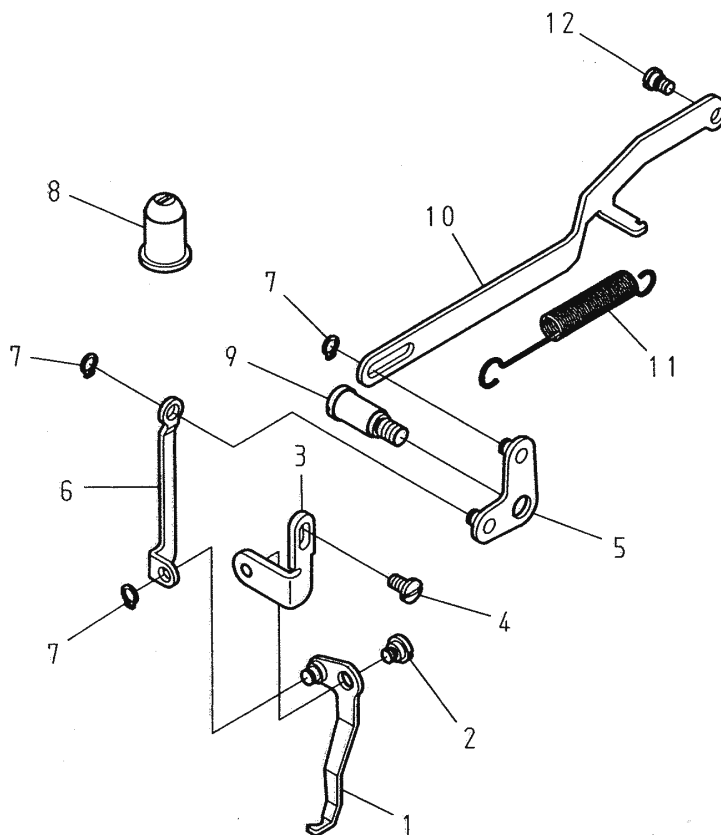

Pos.-Nr. Item No. N° de pos. 序号	Teile-Nr. Part No. N° de pieza 零件号	Menge Freq. Cantida 數量
1	W 3450215104	1
2	W ZSG12010	1
3	W PC1756-0A	1
4	W ZSB11032	1
5	W 3450215604	1
6	W PC1755-0A	1

Pos.-Nr. Item No. N° de pos. 序号	Teile-Nr. Part No. N° de pieza 零件号	Menge Freq. Cantida 數量
7	W RB200050	3
8	W PC1758-0A	1
9	W ZSG16041	1
10	W PC1753-0A	1
11	W 3450216900	1
12	W ZSG11025	1

1.02

Kopfteile
Needle head parts
Piezas de la cabeza
机头零件

PFAFF 3371-1/..

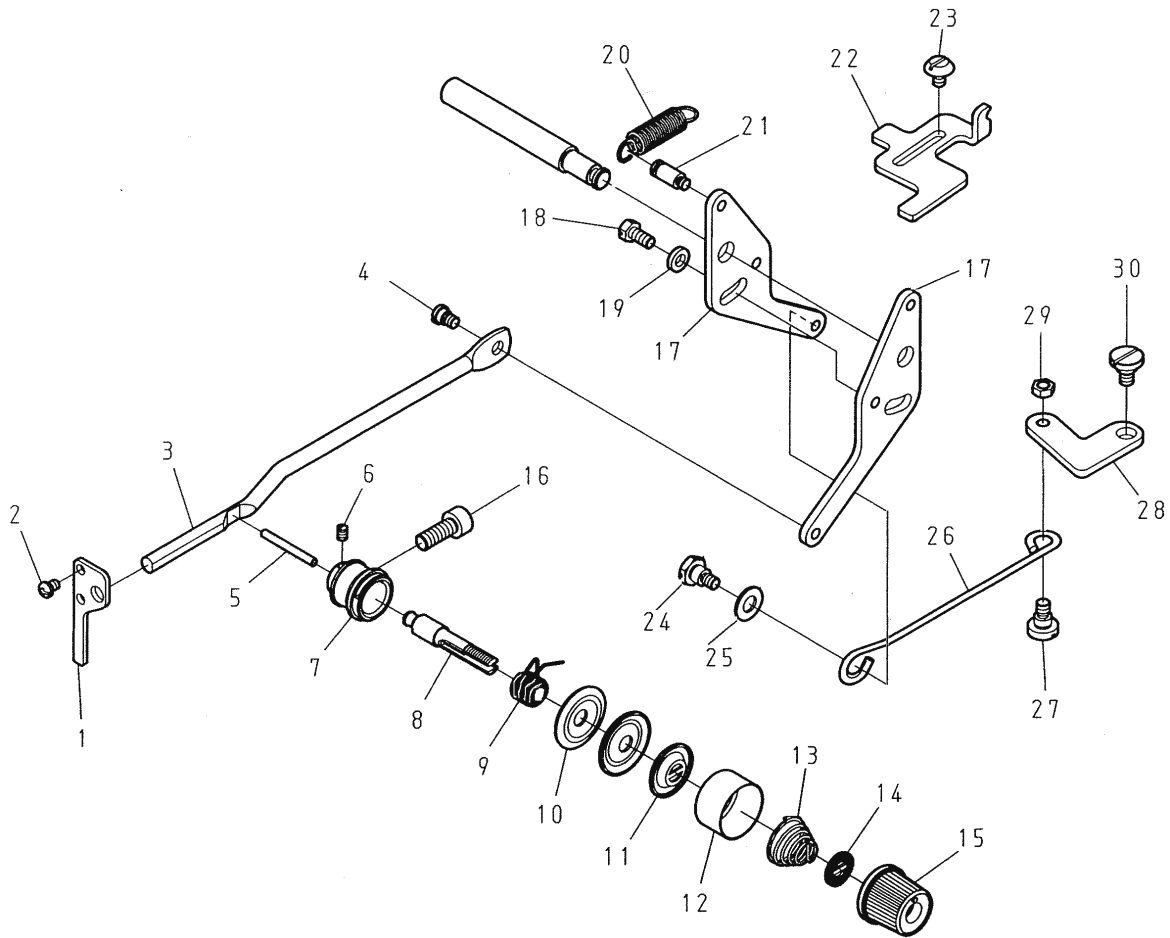

Pos.-Nr. Item No. N° de pos. 序号	Teile-Nr. Part No. N° de pieza 零件号	Menge Freq. Cantidad 數量
1	W PC1332-0A	1
2	W ZSB09025	2
3	W PC1330-0A	1
4	W ZSG11025	1
5	W 3450312200	1
6	W HB1028-0A	1
7	W PC1029-0A	1
8	W PC1026-0A	1
9	W 3450310800	1
10	W HB1025-0A	2
11	W A1022-0A	1
12	W HB1022-0A	1
13	W EJ1021-0A	1
14	W H1042-0A	1
15	W ZSR16009	1

Pos.-Nr. Item No. N° de pos. 序号	Teile-Nr. Part No. N° de pieza 零件号	Menge Freq. Cantidad 數量
16	W ZSJ15007	1
17	W 3450313700	2
18	W ZSD11001	1
19	W WA040008	1
20	W 3450312300	1
21	W ZSK11042	1
22	W 3450318100	1
23	W ZSB11109	2
24	W ZSG11096	1
25	W WA069002	1
26	W 3450312700	1
27	W ZSG12013	1
28	W 3450215500	1
29	W ZSL12004	1
30	W ZSG12071	1

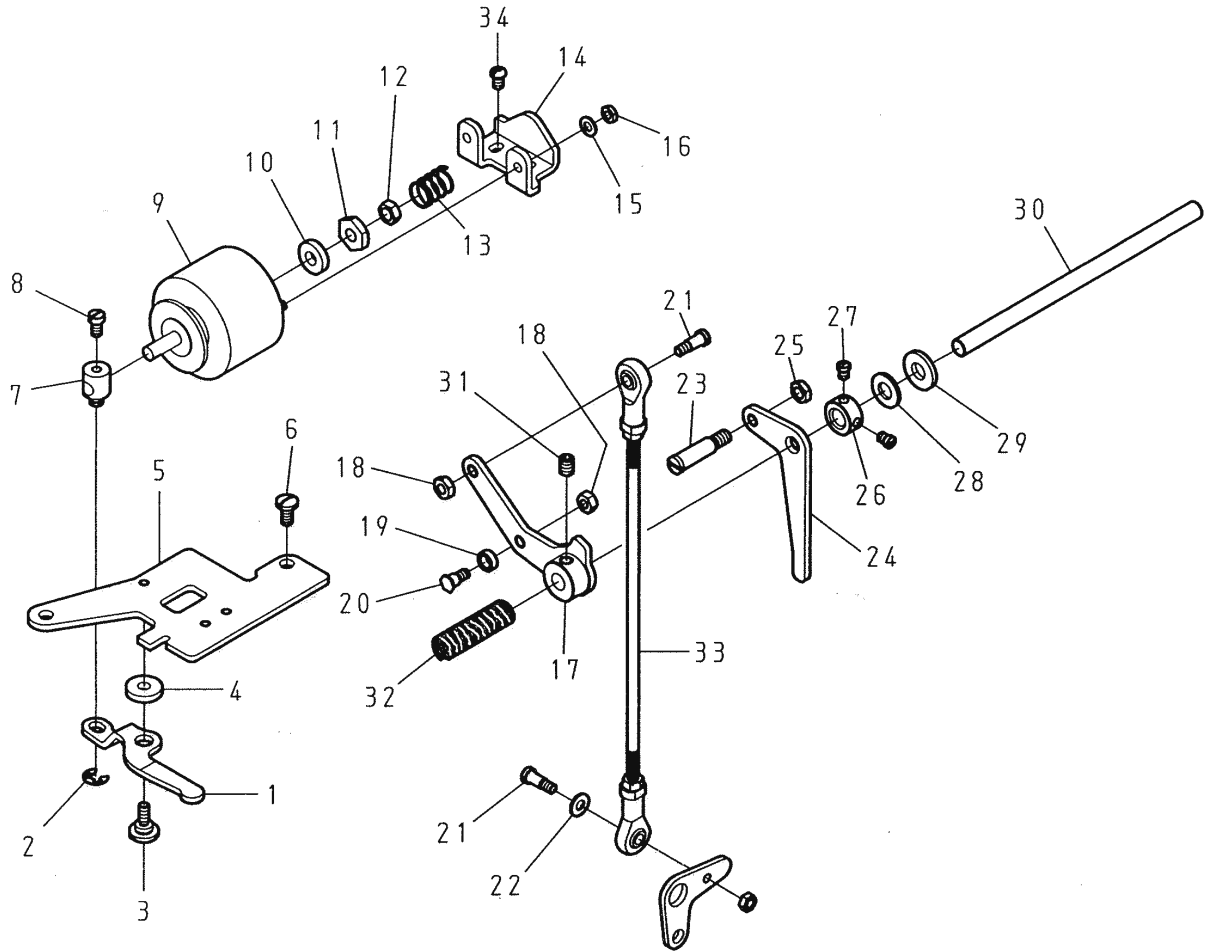

Pos.-Nr. Item No. N° de pos. 序号	Teile-Nr. Part No. N° de pieza 零件号	Menge Freq. Cantidad 數量
1	W 3450241500	1
2	W RE000050	1
3	W ZSG11097	1
4	W WA050016	1
5	W 3450241400	1
6	W ZSB12006	2
7	W 51002408TO	1
8	W ZSB11012	1
9	W 3450240600	1
10	W 51002448TO	1
11	W ZSL16015	1
12	W ZSL16005	1
13	W 3450243900	1
14	W 3450240900	1
15	W WA0449003	2
16	W ZML04002	2
17	W 3450241304	1

Pos.-Nr. Item No. N° de pos. 序号	Teile-Nr. Part No. N° de pieza 零件号	Menge Freq. Cantidad 數量
18	W ZSL11002	2
19	W 3450241700	1
20	W ZSG11098	1
21	W ZSG11095	2
22	W WA059005	1
23	W 3450317200	1
24	W 3450317100	1
25	W ZSL15002	1
26	W 3450245600	1
27	W ZSB11009	2
28	W 3450241600	1
29	W WH208002	1
30	W 3450241000	1
31	W ZSH15002	1
32	W 3450241200	1
33	W 3450241905	1
34	W ZSB11032	2

1.03

Armteile
Arm parts
Piezas del brazo
机臂零件

PFAFF 3371-1/..

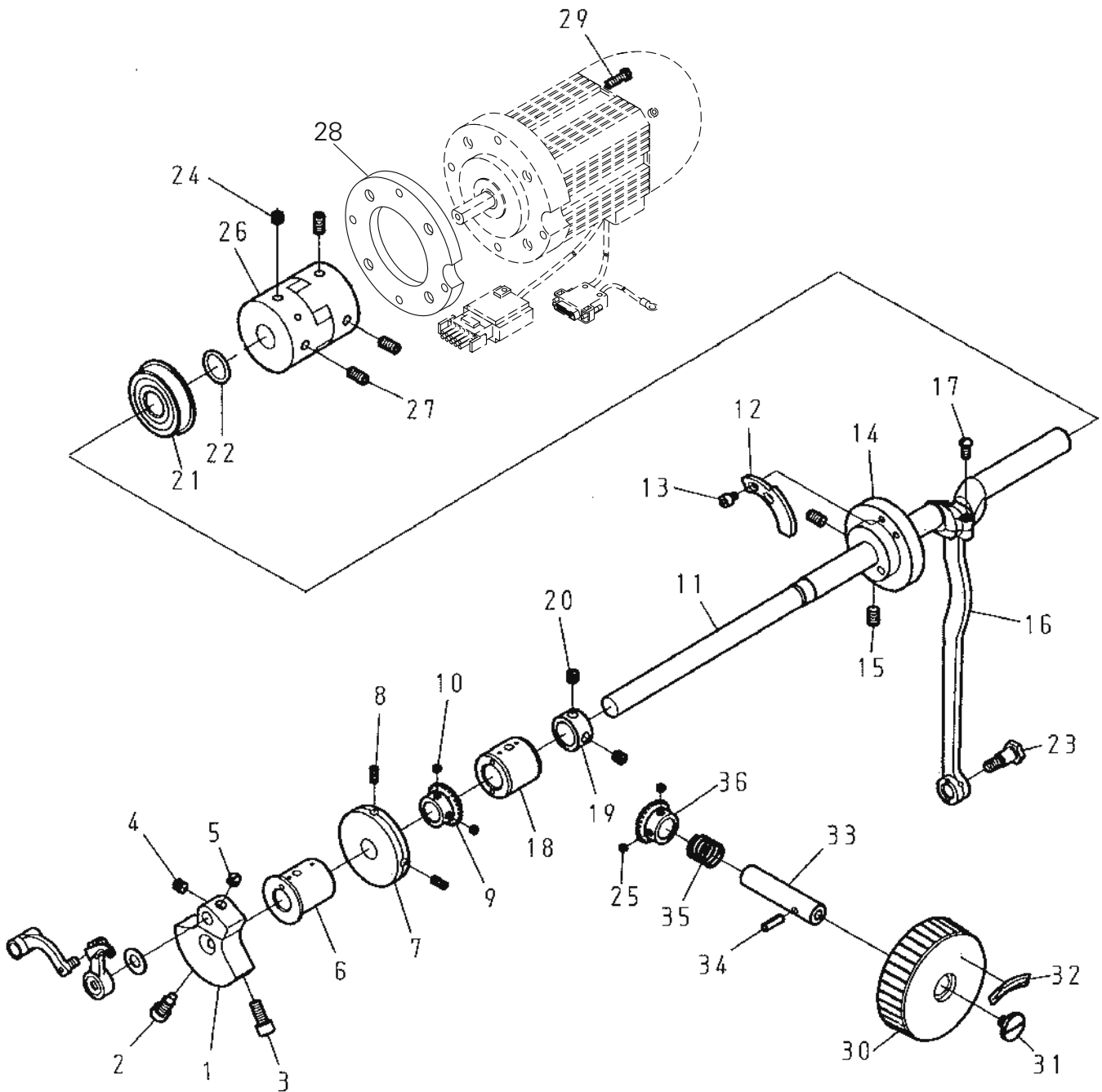

Pos.-Nr. Item No. N° de pos. 序号	Teile-Nr. Part No. N° de pieza 零件号	Menge Freq. Cantida 數量
1	W PC1106-0A	1
2	W ZSJ18001	1
3	W ZSJ15002	1
4	W ZSA16025	1
5	W ZSA16008	1
6	W 3450120200	1
7	W 3450320500	1
8	W ZSA11016	2
9	W 3450123800	1
10	W ZSA11009	2
11	W 3450120100	1
12	W 3450310700	1
13	W ZMJ04008	2
14	W 3450240500	1
15	W ZSH16004	2
16	W 3450181800	1
17	W ZSB11028	2
18	W 3450120300	1
19	W 5100122600	1
20	W ZSA16025	2
21	W BB6302ZZNR	1

Pos.-Nr. Item No. N° de pos. 序号	Teile-Nr. Part No. N° de pieza 零件号	Menge Freq. Cantida 數量
22	W OP001600	1
23	W ZSG16042	1
24	W ZMH06008	1
25	W ZSA11009	2
26	W 3450122700	1
27	W ZMH06005	3
28	W 3450720203	1
29	W ZSB11010	4
30	W 3450123600	1
31	W ZMB06018	1
32	W 3450335400	1
33	W 3450123400	1
34	W YD040014A	1
35	W 3450123500	1
36	W 3450123700	1

1.03

Armteile
Arm parts
Piezas del brazo
机臂零件

PFAFF 3371-1/..

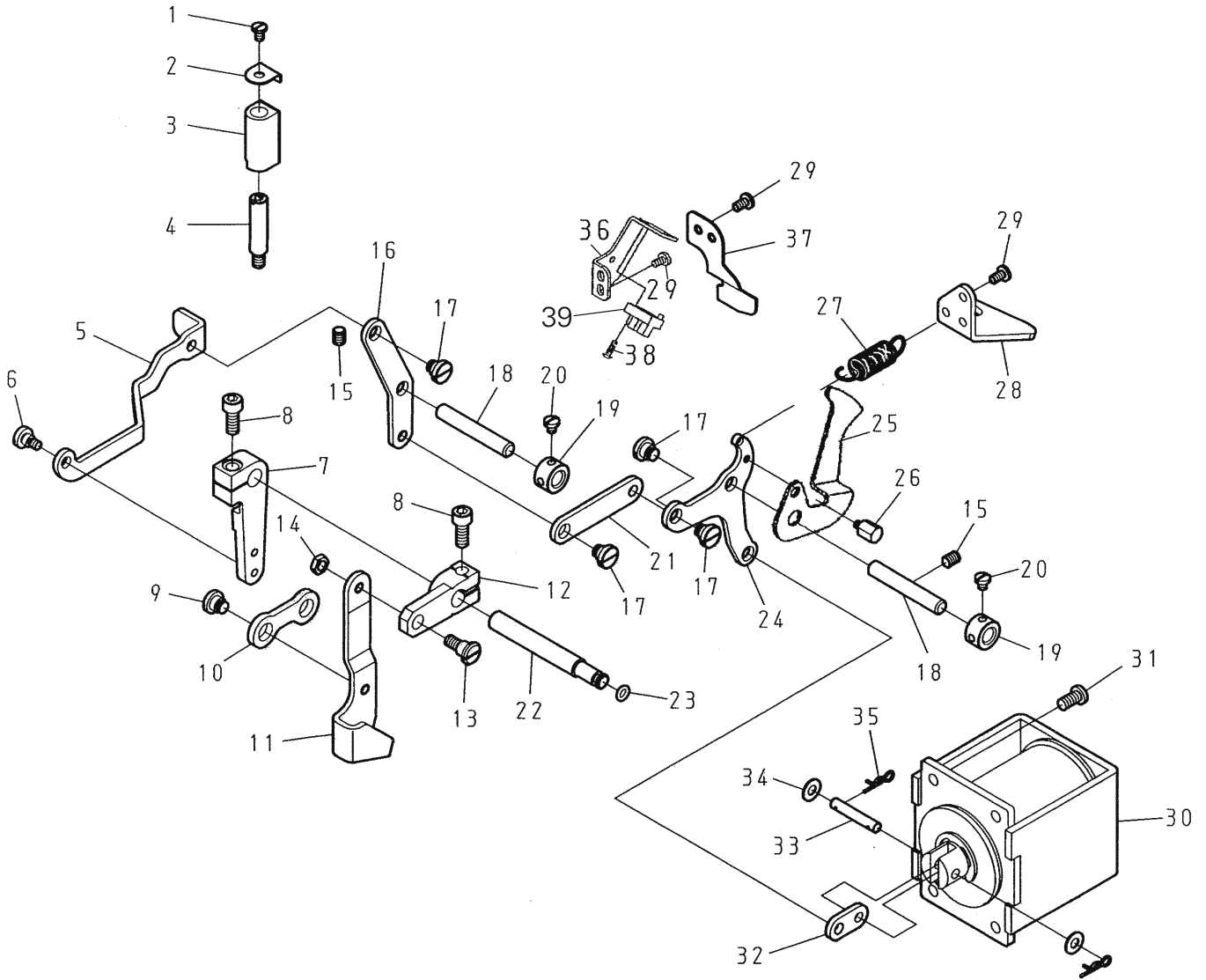

Pos.-Nr. Item No. N° de pos. 序号	Teile-Nr. Part No. N° de pieza 零件号	Menge Freq. Cantida 數量
1	W ZSB11082	1
2	W 3450157700	1
3	W 3450155800	1
4	W 5100351700	1
5	W 3450156000	1
6	W ZSG12013	1
7	W PC1751-0A	1
8	W ZMJ06002	2
9	W ZSG15027	2
10	W 3450157500	1
11	W 3450155100	1
12	W 3450157300	1
13	W ZSG15069	1
14	W ZSL15002	1
15	W ZSH15002	2
16	W 3450156100	1
17	W ZSG16025	4
18	W 3450156400	2
19	W 5100184900	2
20	W ZSB11008	4

Pos.-Nr. Item No. N° de pos. 序号	Teile-Nr. Part No. N° de pieza 零件号	Menge Freq. Cantida 數量
21	W 3450156200	1
22	W 3450156300	1
23	W OPP00500	1
24	W 3450157400	1
25	W 3450156803	1
26	W ZMD04010	1
27	W 3450156700	1
28	W 3450157000	1
29	W ZSB11032	6
30	W 3450155605	1
31	W ZSB15014	4
32	W 3450157800	1
33	W 3450156600	1
34	W WA050015	2
35	WYR000060	2
36	W 3450156903	1
37	W 3450157600	1
38	W ZMB03011	1
39	W 3450606600	1

1.04
 Freiarnteile
 Cylinder bed parts
 Piezas del brazo al aire
 悬臂部分的零件

PFAFF 3371-1/..

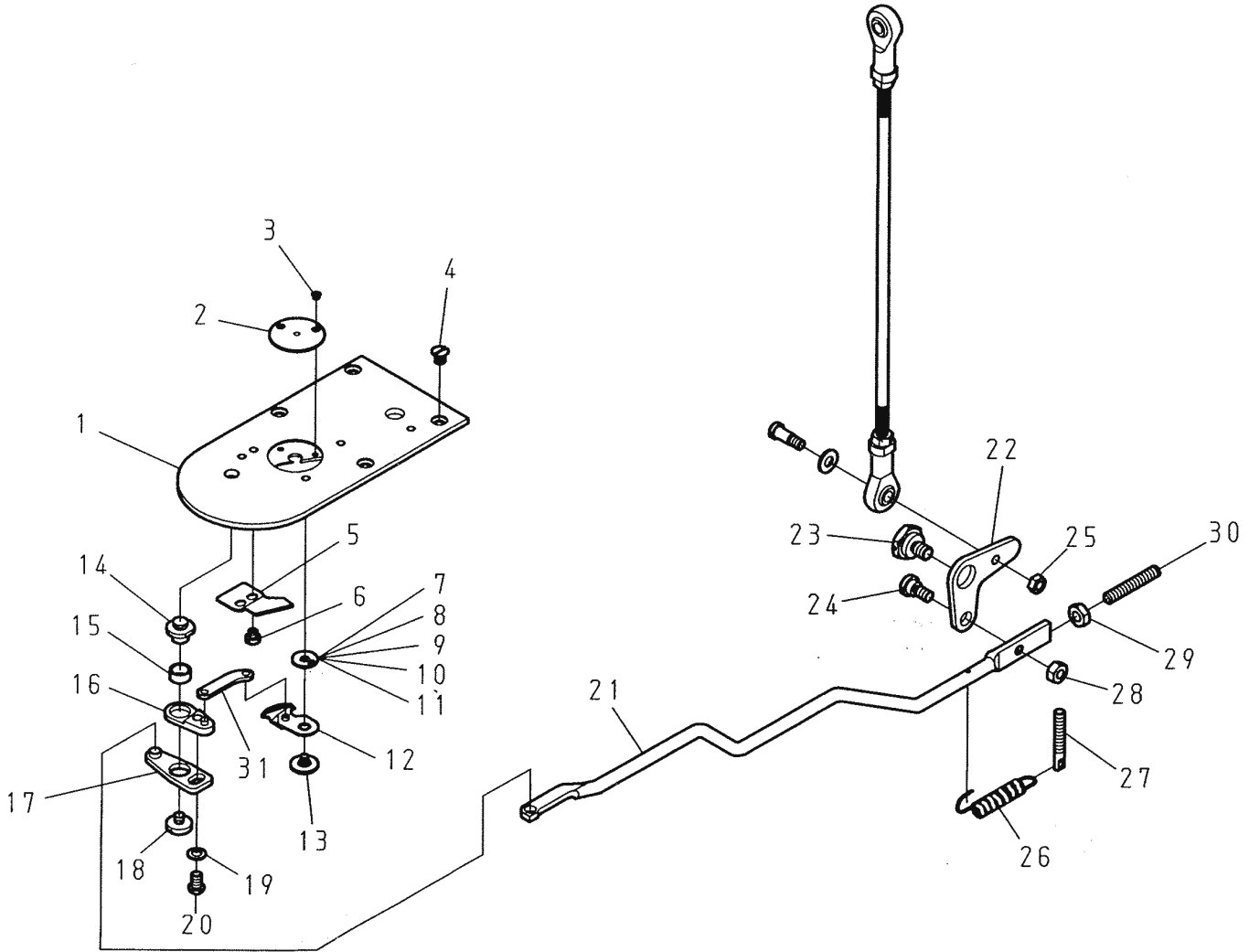

Pos.-Nr. Item No. N° de pos. 序号	Teile-Nr. Part No. N° de pieza 零件号	Menge Freq. Cantida 數量
1	W PC6050-0A	1
2	W 3450112500 (-1/01)	1
	W PC6049-OH (-1/11)	1
3	W ZSC06011	2
4	W ZSC11019	4
5	W PC6111-0A	1
6	W ZSB09040	2
7	W 3450243210 (0,4 mm)	1
8	W 3450243220 (0,5 mm)	1
9	W 3450243230 (0,6 mm)	1
10	W 3450243240 (0,7 mm)	1
11	W 3450243250 (0,8 mm)	1
12	W 3450243005	1
13	W ZSG09037	1
14	W ZSK16036	1
15	W PC6118-0A	1

Pos.-Nr. Item No. N° de pos. 序号	Teile-Nr. Part No. N° de pieza 零件号	Menge Freq. Cantida 數量
16	W 3450245005	1
17	W 3450243405	1
18	W ZSB11043	1
19	W WA040010	1
20	W ZSB11029	1
21	W 3450243700	1
22	W 3450242000	1
23	W ZSG15068	1
24	W ZSG12066	1
25	W ZSL11002	1
26	W 3450242200	1
27	W ZSK11021	1
28	W ZSL12004	1
29	W ZML05001	1
30	W ZMH05011	1
31	W 3450243300	1

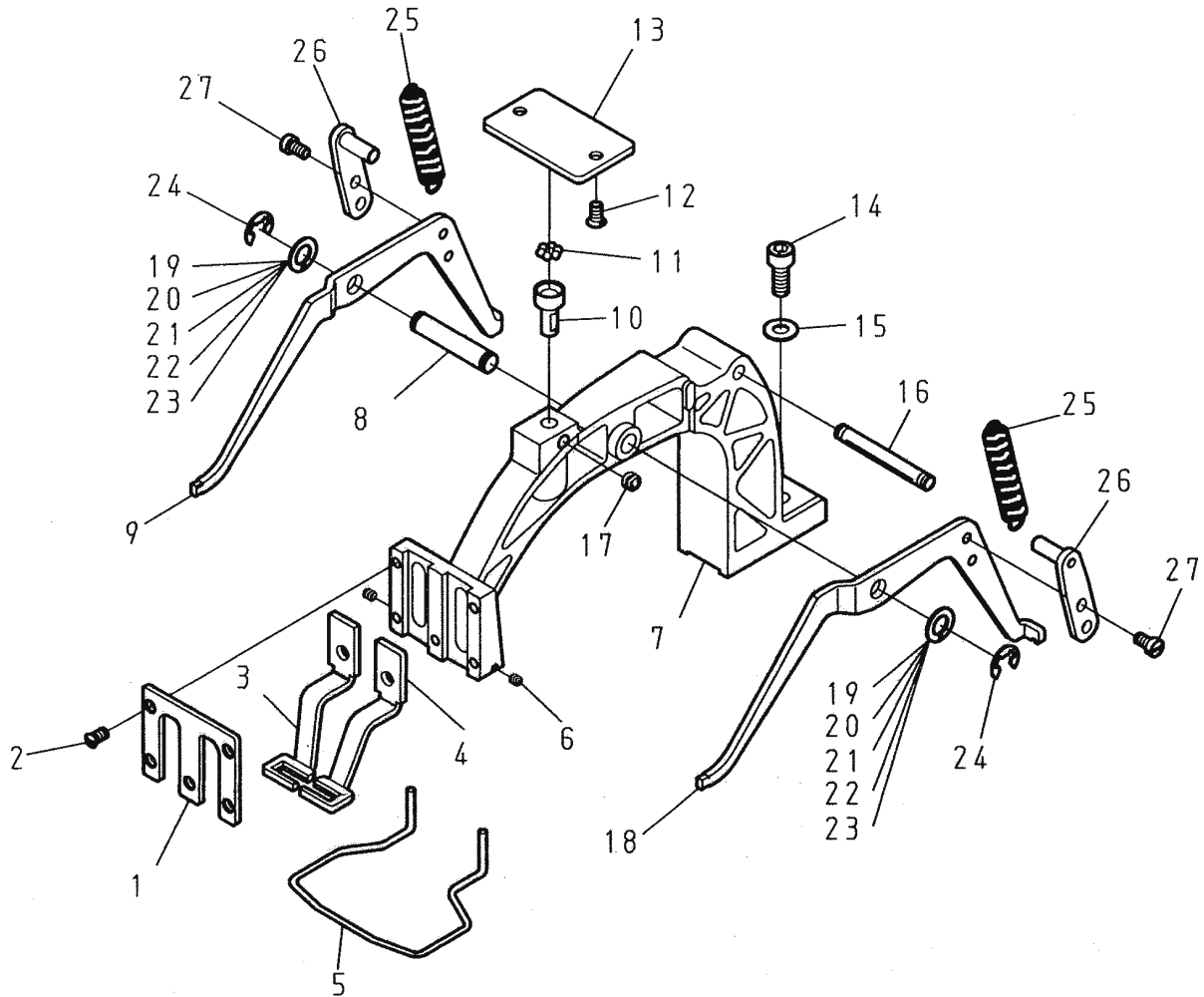

Pos.-Nr. Item No. N° de pos. 序号	Teile-Nr. Part No. N° de pieza 零件号	Menge Freq. Cantidad 數量
1	W PC4186-0A	1
2	W ZSC11017	5
3	W PC4185-0A (-1/01)	1
	W 34501532A1 (-1/11)	1
4	W PC4185-1A (-1/01)	1
	W 34501532A2 (-1/11)	1
5	W 3450141200	1
6	W ZSA08003	2
7	W PC4188-0A	1
8	W PC4190-0A	1
9	W PC4182-0A	1
10	W PC4183-0A	1
11	W OBS00080	7
12	W ZSC11001	2
13	W PC1206-0A	1
14	W ZMJ06002	1

Pos.-Nr. Item No. N° de pos. 序号	Teile-Nr. Part No. N° de pieza 零件号	Menge Freq. Cantidad 數量
15	W WA069001	1
16	W PC4192-0A	1
17	W ZSA15021	1
18	W PC4181-0A	1
19	W 3450158410	2
20	W 3450158420	2
21	W 3450158430	2
22	W 3450158440	2
23	W 3450158450	2
24	W RE000070	2
25	W 3450158300	2
26	W PC4184-0A	2
27	W ZSB11022	4

1.04

Freiarmteile
Cylinder bed parts
Piezas del brazo al aire
悬臂部分的零件

PFAFF 3371-1/..

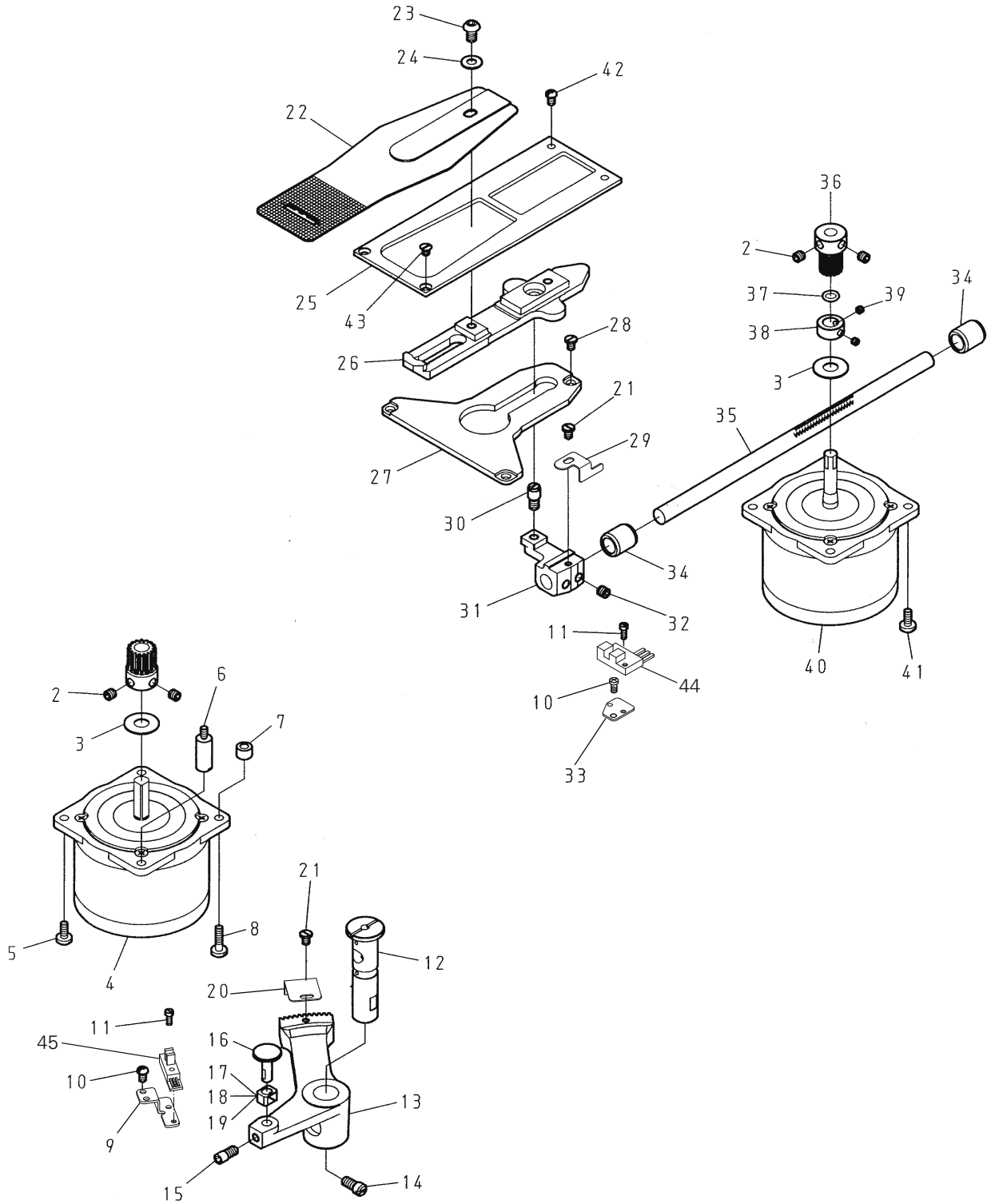

Pos.-Nr. Item No. N° de pos. 序号	Teile-Nr. Part No. N° de pieza 零件号	Menge Freq. Cantida 數量
1	W 3450257800	1
2	W ZMH06008	4
3	W 3450740300	2
4	W 3450730100-B	1
5	W ZSB11114	3
6	W 3450740100	1
7	W 3450740200	1
8	W ZSB11066	1
9	W 3450257003	1
10	W ZSB11029	4
11	W ZMB03011	2
12	W PC4271-0A	1
13	W 3450255300	1
14	W ZSB15046	1
15	W ZSJ15001	1
16	W PC6062-0A	1
17	W 3450141010	1
18	W 3450141020	1
19	W 3450141030	1
20	W 3450257203	1
21	W ZSB11082	2
22	W PC6051-0A (-1/01)	1
22	W 34501532A3 (-1/11)	1

Pos.-Nr. Item No. N° de pos. 序号	Teile-Nr. Part No. N° de pieza 零件号	Menge Freq. Cantida 數量
23	W ZMQ06003	1
24	W WA069001	1
25	W 3450256200	1
26	W 3450257700	1
27	W 3450256500	1
28	W ZSB11082	3
29	W 3450257303	1
30	W PC4272-0A	1
31	W 3450255700	1
32	W ZSH16001	2
33	W 3450257103	1
34	W 3450257600	2
35	W 3450256000	1
36	W 3450257900	1
37	W OPP00680	1
38	W 3450740400	1
39	W ZSA11004	2
40	W 3450730200-B	1
41	W ZSB11114	4
42	W ZSB11029	2
43	W ZSC11019	2
44	W 3450606600	1
45	W 3450606500	1

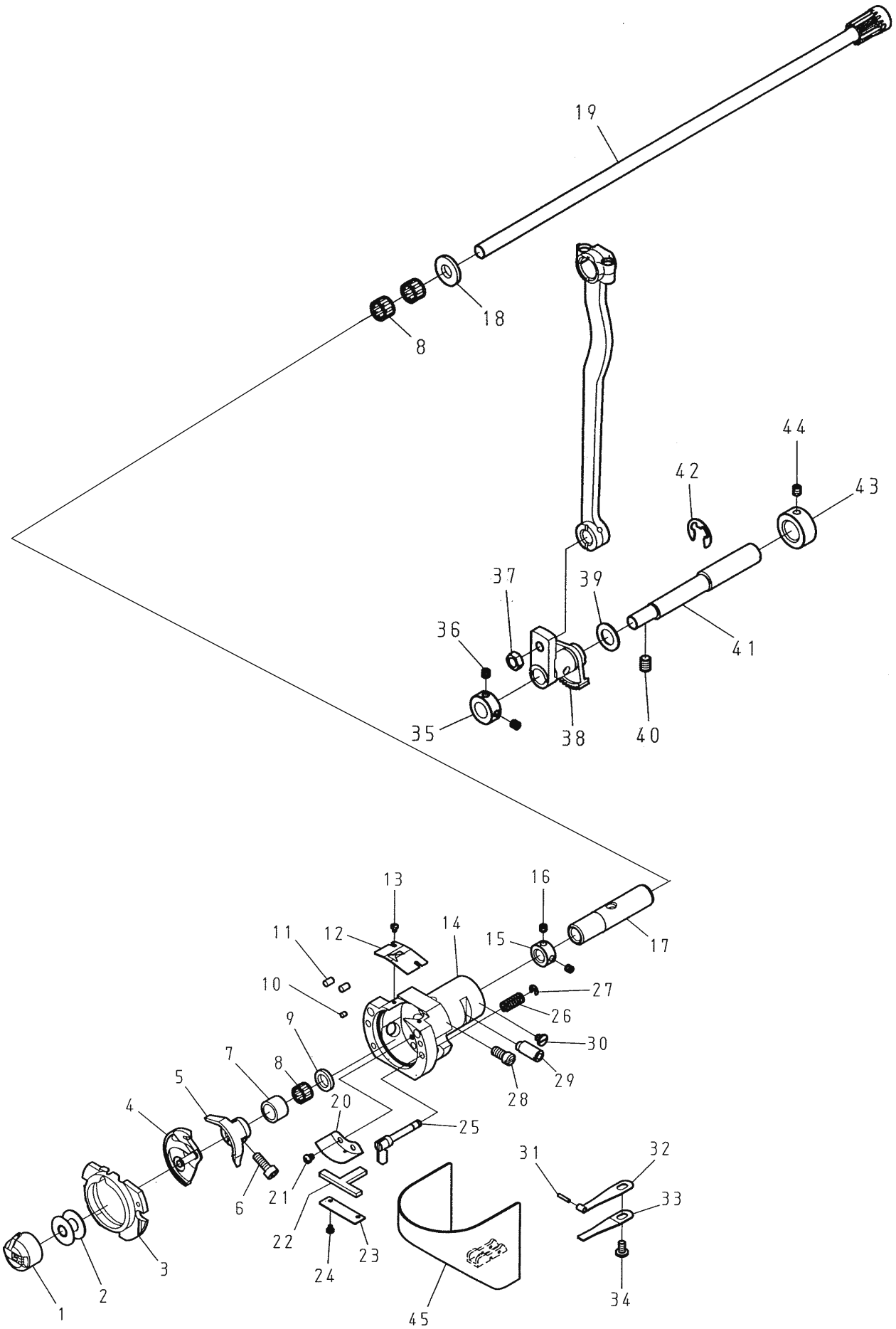

Pos.-Nr. Item No. N° de pos. 序号	Teile-Nr. Part No. N° de pieza 零件号	Menge Freq. Cantida 數量
1	W 3450185300	1
2	W 3450183200	1
3	W 3450185804	1
4	W 3450181300	1
5	W PC6106-0A	1
6	W ZSJ12006	1
7	W 3450180300	1
8	W BN081110	3
9	W WA090007	1
10	W XB103002	1
11	W XB104001	2
12	W PC6101-0A	1
13	W ZSB06019	2
14	W 3450181400	1
15	W 3450245600	1
16	W ZSA11011	2
17	W PC4013-0A	1
18	W WA080015	1
19	W 3450180104	1
20	W PC6107-0A	1
21	W ZSB09024	2
22	W XB400053	1
23	W 3450352800	1

Pos.-Nr. Item No. N° de pos. 序号	Teile-Nr. Part No. N° de pieza 零件号	Menge Freq. Cantida 數量
24	W ZSB06019	2
25	W 3450185604	2
26	W 3450185700	2
27	W RE000030	2
28	W ZSB15046	1
29	W 3450185000	1
30	W ZSB11093	1
31	W YA020100	1
32	W PC6032-0A	1
33	W PC6031-0A	1
34	W ZSB11032	1
35	W 3450184700	1
36	W ZSA11012	2
37	W ZSL16005	1
38	W 3450182500	1
39	W WH210012	1
40	W ZSH15002	1
41	W 3450182300	1
42	W RE000090	1
43	W 34550189100	1
44	W ZSA11005	1
45	W PC6030-0A	1

1.04
 Freiarnteile
 Cylinder bed parts
 Piezas del brazo al aire
 悬臂部分的零件

PFAFF 3371-1/..

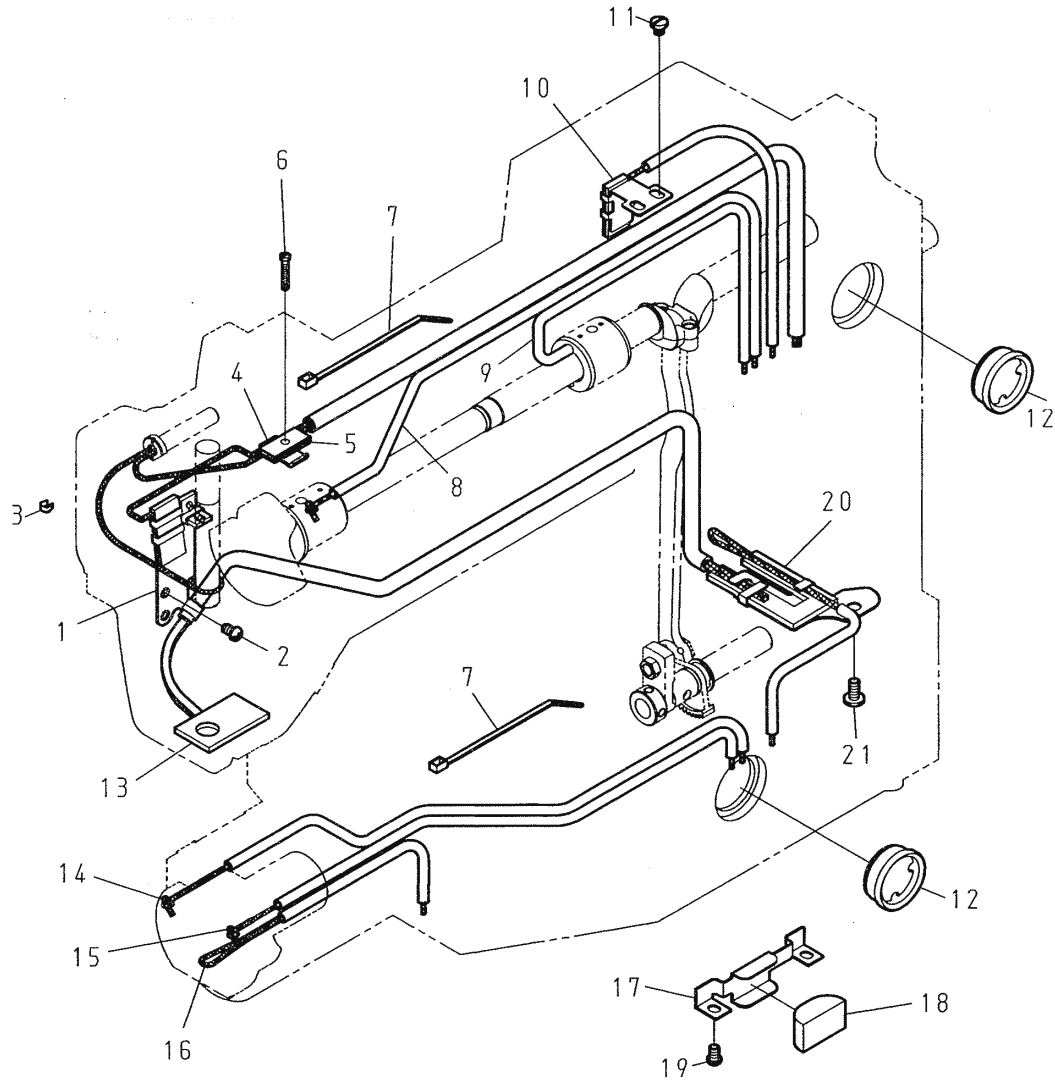

Pos.-Nr. Item No. N° de pos. 序号	Teile-Nr. Part No. N° de pieza 零件号	Menge Freq. Cantidad 數量
1	W 3450352905	1
2	W ZSB11029	2
3	W PC1144-0A	2
4	W PC1145-0A	1
5	W XB400012	1
6	W ZSB09048	1
7	W RU010100	2
8	W 3450357505	1
9	W 3450357605	1
10	W 3450352605	1
11	W ZSB11008	2

Pos.-Nr. Item No. N° de pos. 序号	Teile-Nr. Part No. N° de pieza 零件号	Menge Freq. Cantidad 數量
12	W PA1371-0A	2
13	W XB323001	1
14	W 3450356305	1
15	W 3450356305	1
16	W 3450356405	1
17	W 3450353500	1
18	W XB400051	1
19	W ZSB1029	2
20	W 3450352705	1
21	W ZSB12008	1

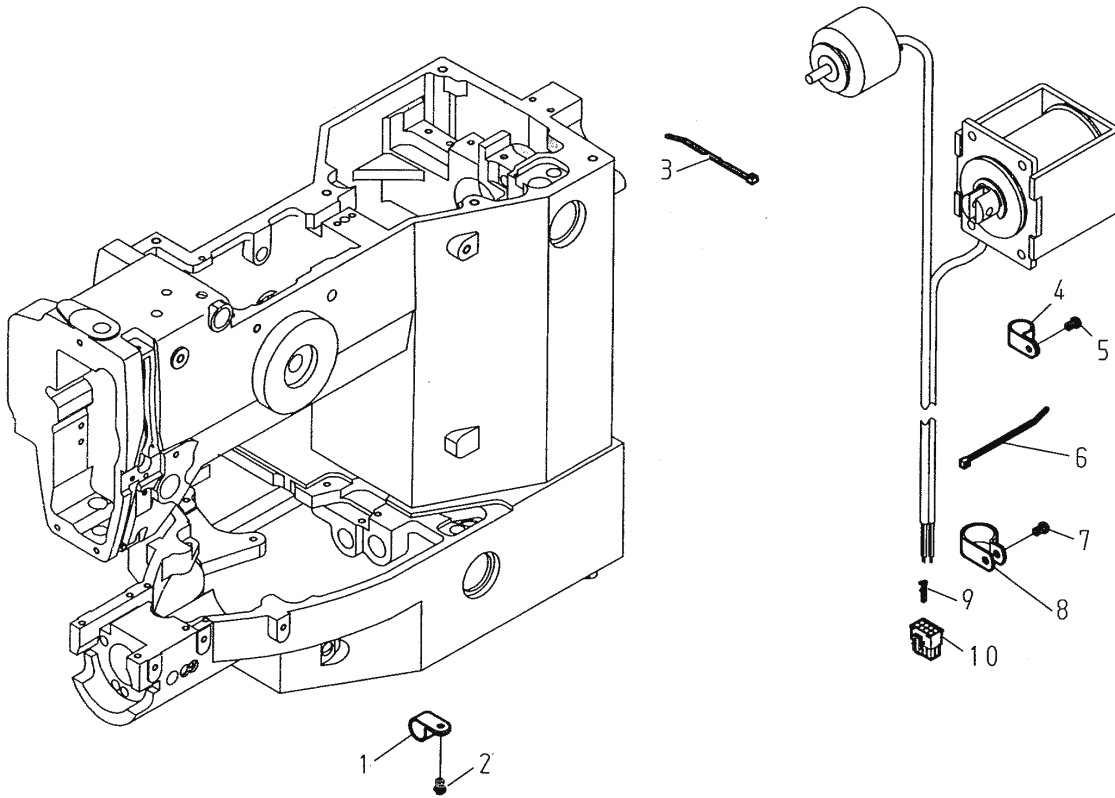

Pos.-Nr. Item No. N° de pos. 序号	Teile-Nr. Part No. N° de pieza 零件号	Menge Freq. Cantidad 數量
1	W RU20UC-3	1
2	W ZSB11029	1
3	W RU010100	1
4	W RU20UC-3	1
5	W RU20UC-3	1

Pos.-Nr. Item No. N° de pos. 序号	Teile-Nr. Part No. N° de pieza 零件号	Menge Freq. Cantidad 數量
6	W RU010100	1
7	W ZSB11029	1
8	W RU20UC-4	1
9	W VJT6657-B1	4
10	W VJT6657-08	1

2.01 Kabelbaum zum Oberteil
Cable tree to sewing head
Mazo de cables para el cabezal
上部机器电缆束

PFAFF 3371-1/..

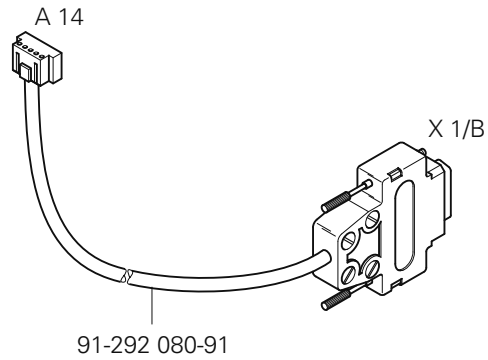
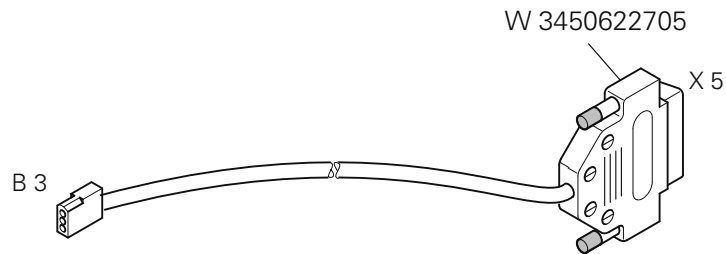
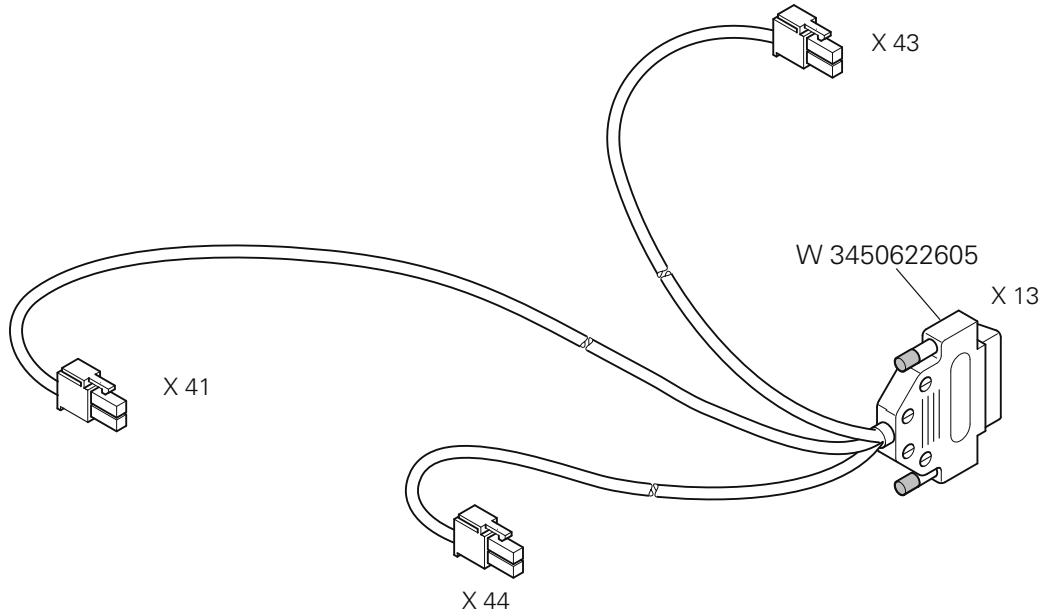

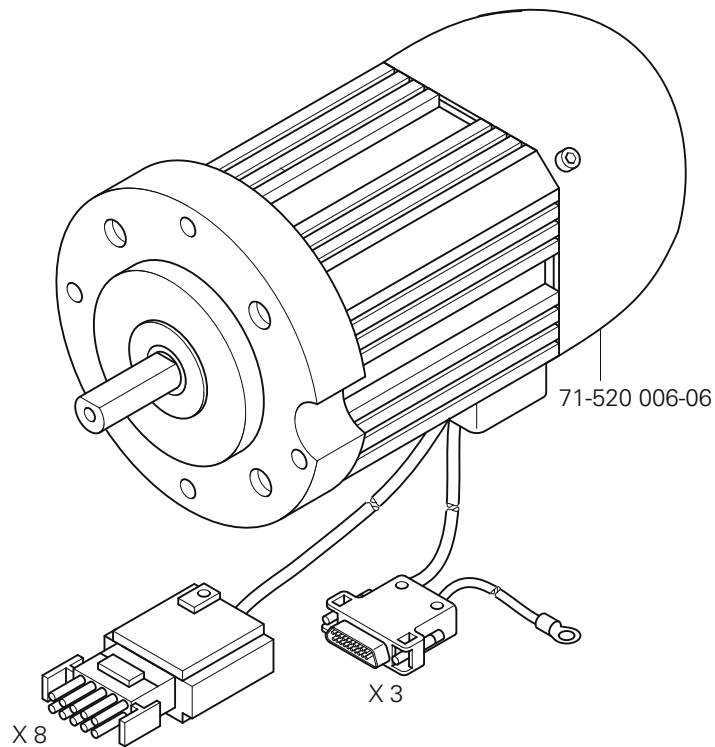
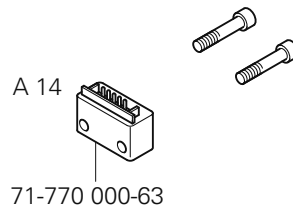

2.04

Bedienfeld
Control panel
Panel de mandos
操作板

PFAFF 3371-1/..

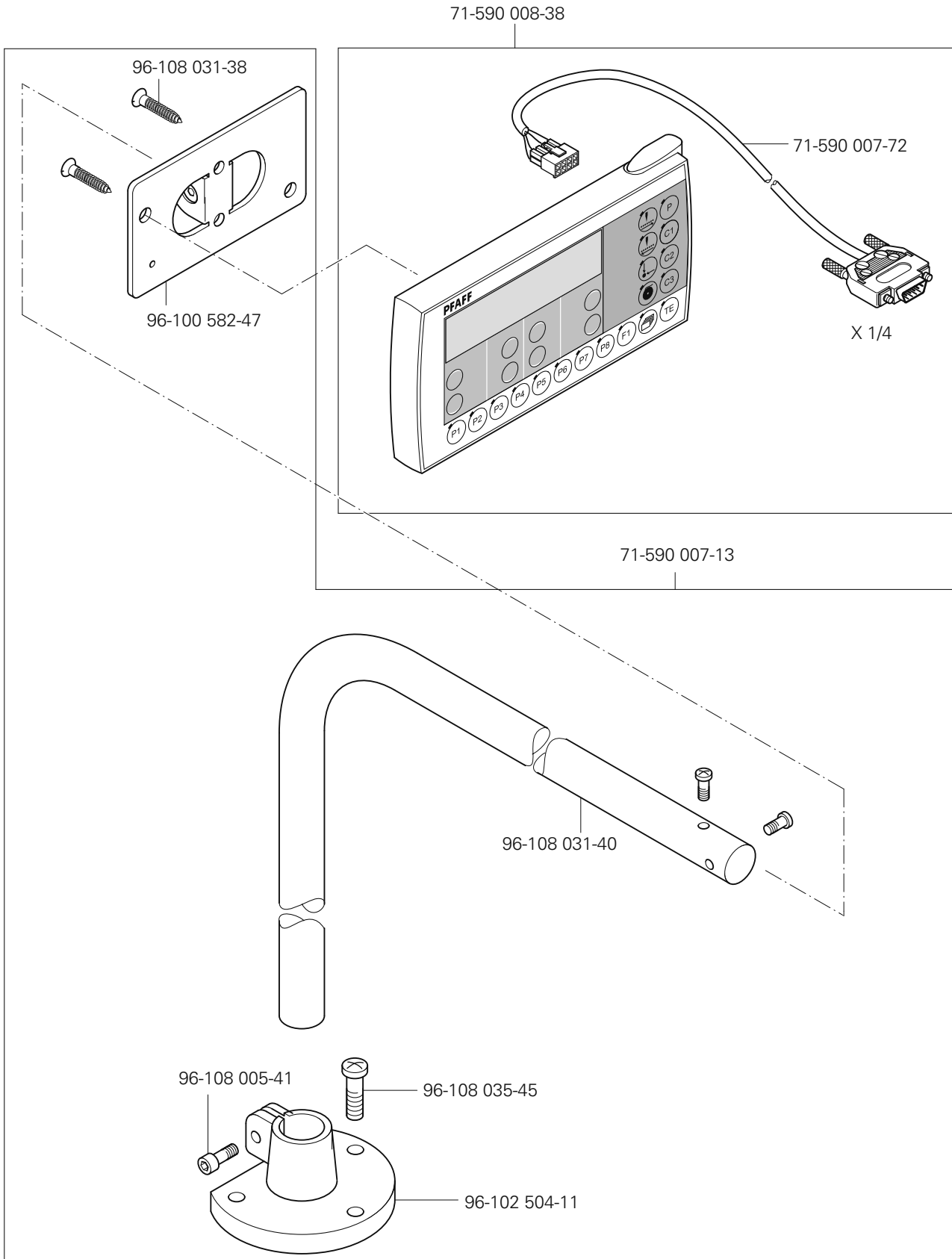

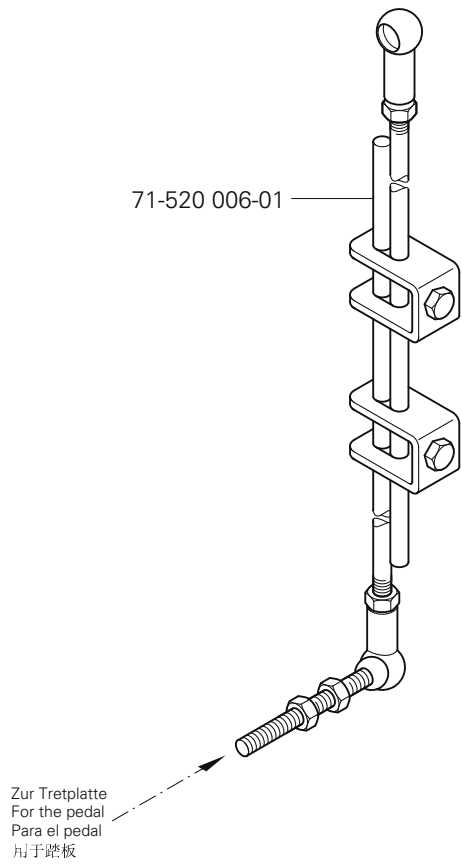
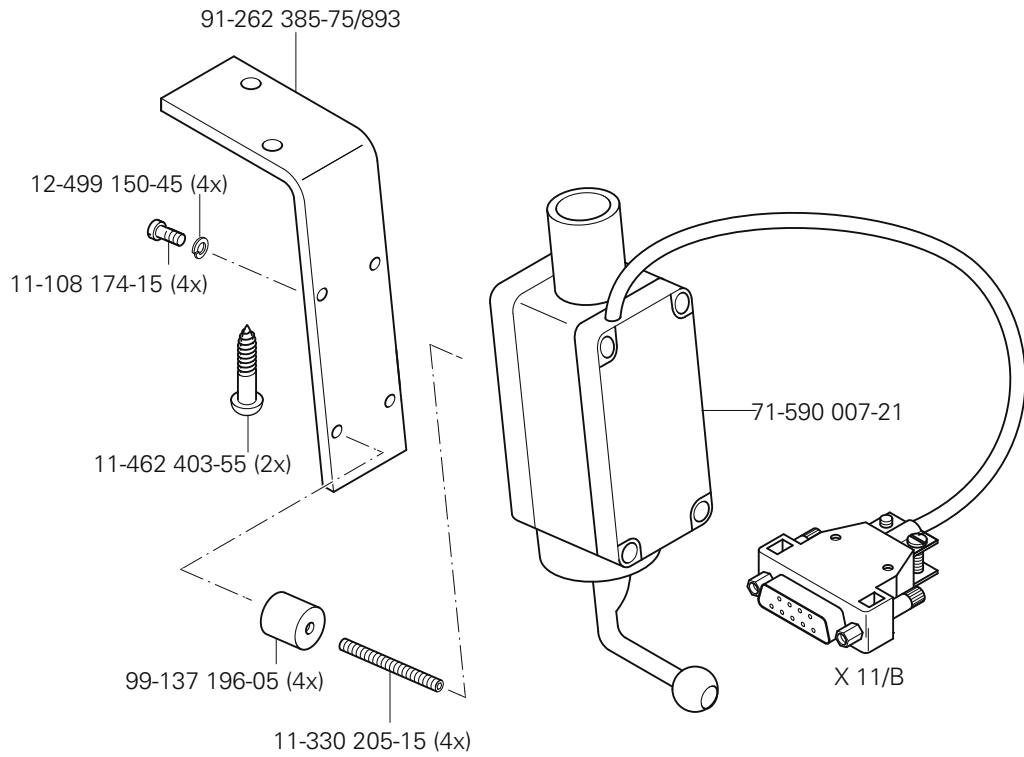

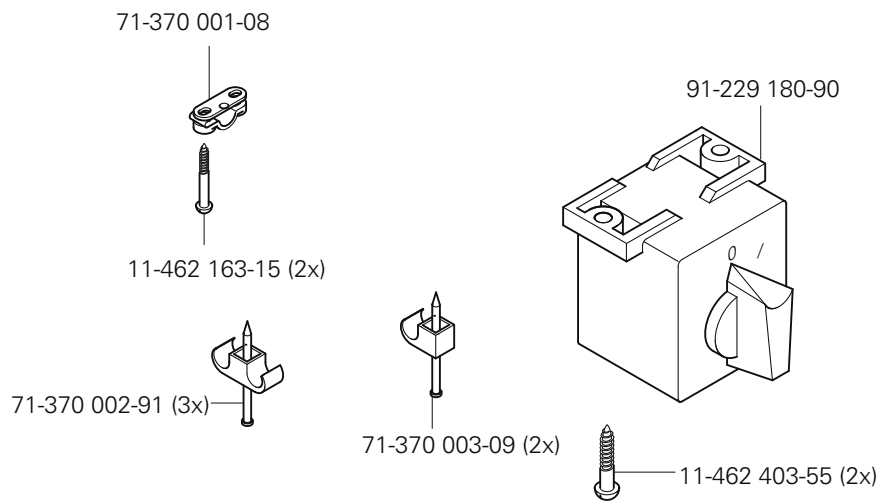

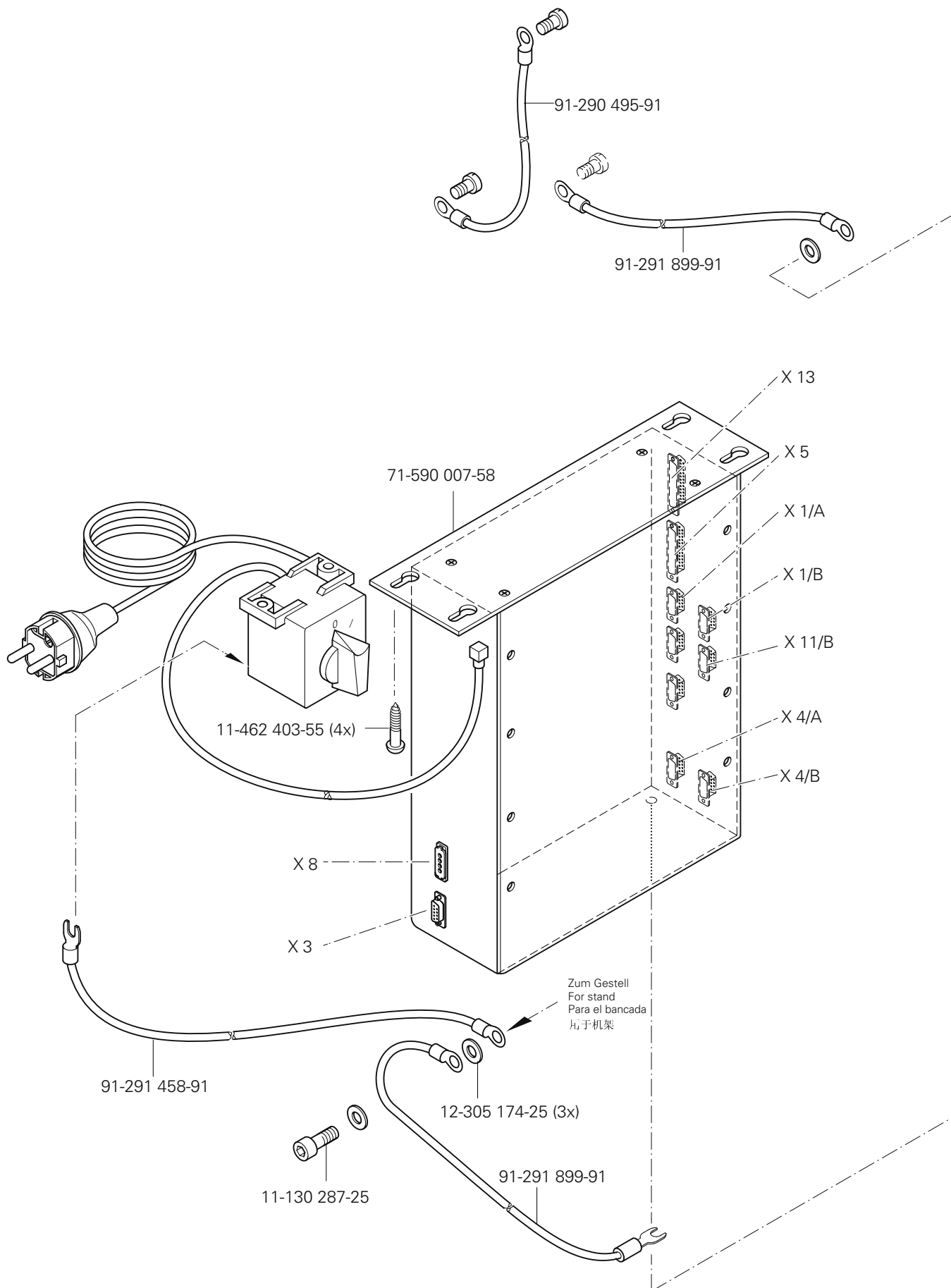

91-229 070-70/895

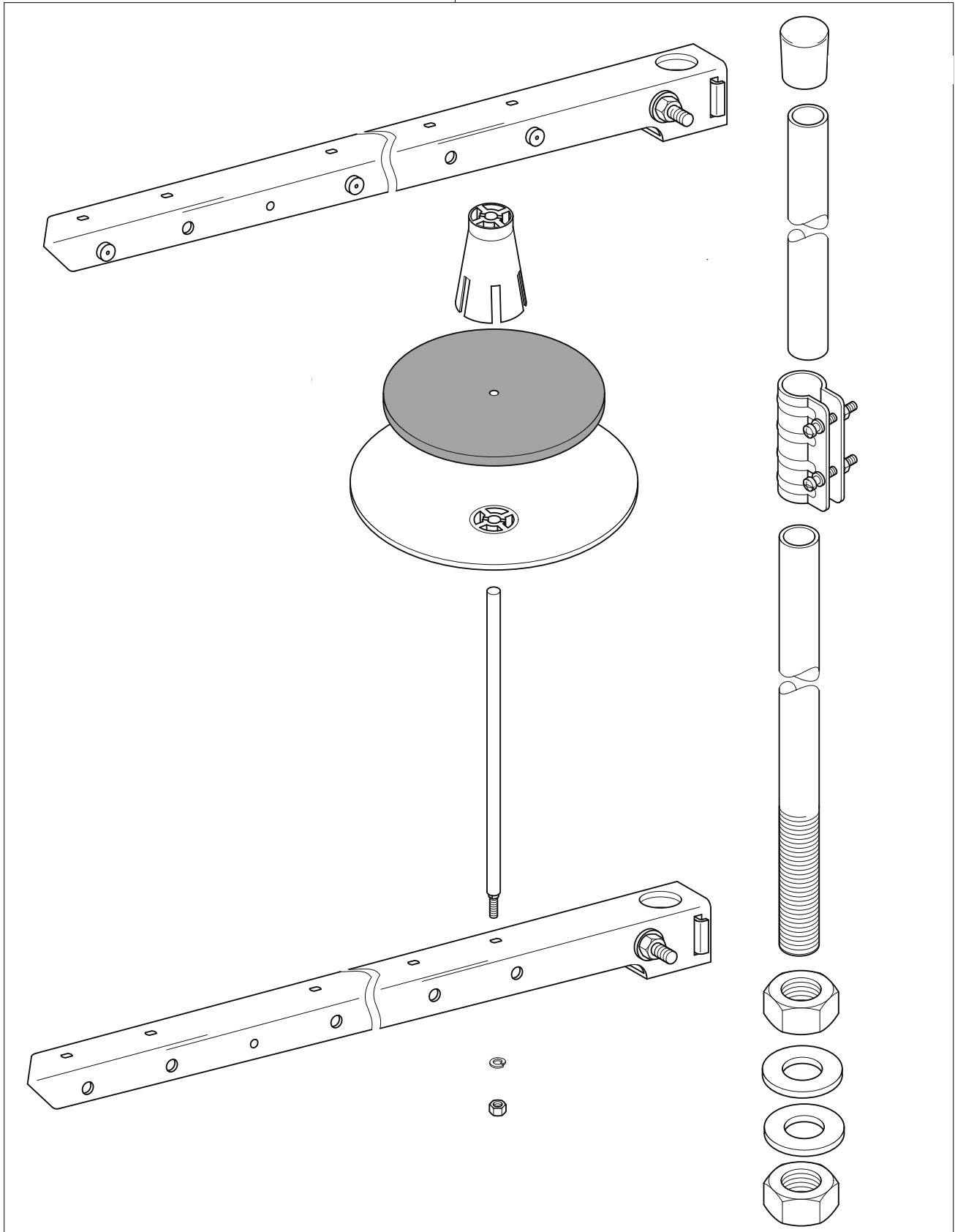

Öl Oil Aceite 油	Mittelpunkts-Viskosität bei: Mean viscosity at: Viscosidad media a: 中点粘度:		Dichte bei: Density of: Densidad a: 密度, 在:		Bestellnummer für Behälter mit: Part number for can with: Número de pedido para recipientes con: 订货号用于油箱, 带:		
	°C	mm ² /s	°C	g/cm ³ (g/ml)	1 Liter 1 Litre 1 Litro 1 升	5 Liter 5 Litre 5 Litros 5 升	10 Liter 10 Litre 10 Litros 10 升
28-011 201-05	40	10,0	15	0,847	91-027 975-91		

Fett Grease Grasa 脂	Penetration Penetration Penetración 贯入度	Tropfpunkt Drip-point Punto de goteo 滴点	Bestellnummer für Behälter mit: Part number for can with: Número de pedido para recipientes con: 订货号用于油箱, 带:		
	mm/10	°C	0,25 kg	0,5 kg	1 kg

Reinigungsmittel Cleansing agent Limpiadores 清洁剂	Bestellnummer für Behälter mit: Part number for can with: Número de pedido para recipientes con: 订货号用于油箱, 带:
	240 ml

No. 零件号	Seite Page Página 页号	No. 零件号	Seite Page Página 页号	No. 零件号	Seite Page Página 页号	No. 零件号	Seite Page Página 页号
11-108 174-15	29	96-102 504-11	28	W 3450140700	10	W 3450158410	19
11-130 287-25	31	96-108 005-41	28	W 3450141010	10, 21	W 3450158420	19
11-330 205-15	29	96-108 031-38	28	W 3450141020	10, 21	W 3450158430	19
11-462 163-15	30	96-108 031-40	28	W 3450141030	10, 21	W 3450158440	19
11-462 403-55	29, 30, 31	96-108 035-45	28	W 3450141200	19	W 3450158450	19
12-305 174-25	31	99-137 196-05	29	W 34501532A1	19	W 3450180104	23
12-499 150-45	29	W 3450110401	7	W 34501532A2	19	W 3450180300	23
28-011 201-05	33	W 3450110500	9	W 34501532A3	21	W 3450181300	23
71-370 001-08	30	W 3450110801	7	W 3450155100	17	W 3450181400	23
71-370 002-91	30	W 3450111000	7	W 3450155605	17	W 3450181800	15
71-370 003-09	30	W 3450111100	7	W 3450155800	17	W 3450182300	23
71-520 006-01	29	W 3450112500	18	W 3450156000	17	W 3450182500	23
71-520 006-06	27	W 3450114300	7	W 3450156100	17	W 3450183200	23
71-590 007-13	28	W 3450114800	7	W 3450156200	17	W 3450184700	23
71-590 007-21	29	W 3450119000	9	W 3450156300	17	W 3450185000	23
71-590 007-58	31	W 3450120100	15	W 3450156400	17	W 3450185300	23
71-590 007-72	28	W 3450120200	15	W 3450156600	17	W 3450185604	23
71-590 008-38	28	W 3450120300	15	W 3450156700	17	W 3450185700	23
71-770 000-63	27	W 3450121000	10	W 3450156803	17	W 3450185804	23
91-027 975-91	33	W 3450121300	10	W 3450156903	17	W 3450189100	23
91-229070- 70/89532		W 3450122700	15	W 3450157000	17	W 3450190105	10
91-229 180-90	30	W 3450123400	15	W 3450157300	17	W 3450190700	10
91-262385- 75/89329		W 3450123500	15	W 3450157400	17	W 3450215104	11
91-290 495-91	31	W 3450123600	15	W 3450157500	17	W 3450215500	12
91-291 458-91	31	W 3450123700	15	W 3450157600	17	W 3450215604	11
91-291 899-91	31	W 3450123800	15	W 3450157700	17	W 3450216900	11
91-292 080-91	26	W 3450140100	10	W 3450157800	17	W 3450240500	15
96-100 582-47	28	W 3450140500	10	W 3450158300	19	W 3450240600	13

No. 零件号	Seite Page Página 页号	No. 零件号	Seite Page Página 页号	No. 零件号	Seite Page Página 页号	No. 零件号	Seite Page Página 页号
W 3450240900	13	W 3450257003	21	W 3450322000	9	W 3450730100-B	21
W 3450241000	13	W 3450257103	21	W 3450322100	9	W 3450730200-B	21
W 3450241200	13	W 3450257203	21	W 3450322404	9	W 3450740100	21
W 3450241304	13	W 3450257303	21	W 3450322600	9	W 3450740200	21
W 3450241400	13	W 3450257600	21	W 3450322800	9	W 3450740300	21
W 3450241500	13	W 3450257700	21	W 3450322900	9	W 3450740400	21
W 3450241600	13	W 3450257800	21	W 3450335400	15	W 3450911500	9
W 3450241700	13	W 3450257900	21	W 3450336100	9	W 3450911700	9
W 3450241905	13	W 3450310700	15	W 3450339000	9	W 3450913700	9
W 3450242000	18	W 3450310800	12	W 3450350100	9	W 4710320400	9
W 3450242200	18	W 3450312200	12	W 3450352605	24	W 5100122600	15
W 3450243005	18	W 3450312300	12	W 3450352705	24	W 5100140900	10
W 3450243210	18	W 3450312700	12	W 3450352800	23	W 5100184900	17
W 3450243220	18	W 3450313300	7	W 3450352905	24	W 51002408TO	13
W 3450243230	18	W 3450313400	7	W 3450353500	24	W 51002448TO	13
W 3450243240	18	W 3450313700	12	W 3450356305	24	W 5100311600	7
W 3450243250	18	W 3450317100	13	W 3450356405	24	W 5100315300	9
W 3450243300	18	W 3450317200	13	W 3450357505	24	W 51003155TO	9
W 3450243405	18	W 3450318100	12	W 3450357605	24	W 5100351700	17
W 3450243700	18	W 3450320104	9	W 3450602405	15	W A1022-0A	12
W 3450243900	13	W 3450320105	9	W 3450602406	15	W BB6302ZZNR	15
W 3450245005	18	W 3450320500	15	W 3450603700	15	W BN081110	10, 23
W 3450245600	13, 23	W 3450320904	9	W 3450606500	20	W BNKT8128	10
W 3450255300	21	W 3450321100	9	W 3450606600	16, 20	W EJ1021-0A	12
W 3450255700	21	W 3450321200	9	W 3450622605	26	W H1042-0A	12
W 3450256000	21	W 3450321500	9	W 3450622705	26	W H7151-0A	7
W 3450256200	21	W 3450321700	9	W 3450710100	15	W HB1022-0A	12
W 3450256500	21	W 3450321800	9	W 3450720203	27	W HB1025-0A	7, 12

No. 零件号	Seite Page Página 页号	No. 零件号	Seite Page Página 页号	No. 零件号	Seite Page Página 页号	No. 零件号	Seite Page Página 页号
W HB1028-0A	12	W PC1332-0A	12	W PC6111-0A	18	W WA060017	7
W HB1054-0A	7	W PC1751-0A	17	W PC6118-0A	18	W WA069001	19, 21
W HB1086-0A	7	W PC1753-0A	11	W PC7150-0A	7	W WA069002	12
W HB1088-0A	7	W PC1755-0A	11	W PC7152-0A	7	W WA069005	9
W INDPx17-19	10	W PC1756-0A	11	W RB200050	11	W WA080015	23
W OBS00080	19	W PC1758-0A	11	W RB200060	9	W WA090007	23
W OP001600	15	W PC4013-0A	23	W RE000030	23	W WARN000500	7
W OPP0040100	9	W PC4181-0A	19	W RE000050	9	W WH208002	10, 13
W OPP00500	17	W PC4182-0A	19	W RE000050	13	W WH210012	23
W OPP00680	21	W PC4183-0A	19	W RE000070	19	W XA301000	9
W OPP0092270	9	W PC4184-0A	19	W RE000090	23	W XB103002	23
W PA1371-0A	24	W PC4185-0A	17	W RU010100	24, 25	W XB104001	23
W PC1013-0A	7	W PC4185-1A	17	W RU20UC-3	25	W XB323001	24
W PC1021-1A	7	W PC4186-0A	19	W RU20UC-4	25	W XB400012	24
W PC1026-0A	12	W PC4188-0A	19	W SEN0700700	7	W XB400051	24
W PC1026-1A	7	W PC4190-0A	19	W SEN1000500	7, 9	W XB400053	23
W PC1029-0A	12	W PC4192-0A	19	W SEN1205400	7	W YA020100	23
W PC1053-0A	7	W PC4271-0A	21	W SEN1250400	7	W YA079310	9
W PC1055-0A	7	W PC4272-0A	21	W SEN1407000	7	W YD020006	7
W PC1064-0A	10	W PC6030-0A	23	W VJT6657-08	25	W YD040014A	15
W PC1071-0A	10	W PC6031-0A	23	W VJT6657-B1	25	W YR000060	17
W PC1083-0A	7	W PC6032-0A	23	W WA040008	12	W ZMB03011	17, 21
W PC1085-0A	10	W PC6050-0A	18	W WA040010	18	W ZMB06018	15
W PC1106-0A	15	W PC6051-0A	21	W WA0449003	13	W ZMB06019	15
W PC1144-0A	24	W PC6062-0A	21	W WA049006	7	W ZMD04010	17
W PC1145-0A	24	W PC6101-0A	23	W WA050015	17	W ZME04003	15
W PC1206-0A	19	W PC6106-0A	23	W WA050016	13	W ZMH05011	18
W PC1330-0A	12	W PC6107-0A	23	W WA059005	13	W ZMH06005	15

No. 零件号	Seite Page Página 页号	No. 零件号	Seite Page Página 页号	No. 零件号	Seite Page Página 页号	No. 零件号	Seite Page Página 页号
W ZMH06008	15, 21	W ZSB1029	24	W ZSG11025	11, 12	W ZSK12028	7
W ZMJ04008	15	W ZSB11008	17, 24	W ZSG11062	7	W ZSK16036	18
W ZMJ06002	17, 19	W ZSB11009	13	W ZSG11095	13	W ZSL09001	7
W ZMJ06018	9	W ZSB11010	15	W ZSG11096	12	W ZSL11002	13, 18
W ZML04002	13	W ZSB11012	13	W ZSG11097	13	W ZSL11007	7, 9
W ZML05001	18	W ZSB11022	19	W ZSG11098	13	W ZSL12004	7, 12, 18
W ZML06001	9	W ZSB11028	7, 15	W ZSG12010	11	W ZSL15002	13, 17
W ZMQ06003	21	W ZSB11029	7, 9, 18, 21, 24	W ZSG12013	12, 17	W ZSL16005	13, 23
W ZMT03008	9	W ZSB11032	7, 11, 13, 17, 23	W ZSG12066	18	W ZSL16015	13
W ZSA08003	19	W ZSB11043	18	W ZSG12071	12	W ZSN16004	7
W ZSA11004	21	W ZSB11066	21	W ZSG15027	17	W ZSR16009	12
W ZSA11005	23	W ZSB11082	7, 17, 21	W ZSG15068	18		
W ZSA11009	15	W ZSB11093	23	W ZSG15069	17		
W ZSA11011	23	W ZSB11109	12	W ZSG16025	17		
W ZSA11012	23	W ZSB11114	9, 21	W ZSG16041	11		
W ZSA11016	15	W ZSB12006	13	W ZSG16042	15		
W ZSA15021	19	W ZSB15005	9	W ZSH11004	9		
W ZSA16008	15	W ZSB15007	10	W ZSH15002	13, 17, 23		
W ZSA16025	15	W ZSB15014	17	W ZSH16001	21		
W ZSB06019	23	W ZSB15027	7	W ZSH16004	15		
W ZSB08010	10	W ZSB15046	21, 23	W ZSJ12006	23		
W ZSB09014	10	W ZSC06011	18	W ZSJ15001	21		
W ZSB09020	7,9	W ZSC11001	19	W ZSJ15002	15		
W ZSB09024	23	W ZSC11017	19	W ZSJ15007	12		
W ZSB09025	12	W ZSC11019	18, 21	W ZSJ18001	15		
W ZSB09040	18	W ZSD11001	12	W ZSK09005	10		
W ZSB09048	24	W ZSE11002	7	W ZSK11021	18		
W ZSB10029	25	W ZSG09037	18	W ZSK11042	12		





3371-1/..

Unterklassen-Ausstattung

Subclass parts

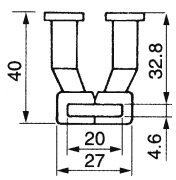
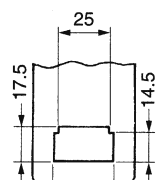
Composición de las subclases

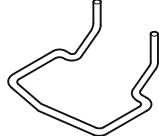
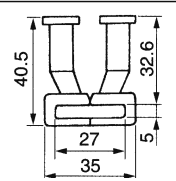
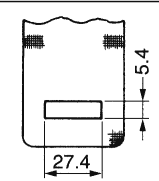
子机型-设备

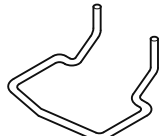
Unterklasse Subclasse Subclase 子机型	Verwendungszweck Applications Fin de empleo 使用目的	Klammerfuß Work clamp foot Pinza-prensateles 夹脚	Auflageplatte Feed plate Placa de apoyo 垫板	Stichplatteneinsatz Needle plate insert Suplemento de la placa de aguja 针板部件	Fingerschutz Finger guard Protector de dedos 护指器	Teilesatz komplett Complete parts set Juego de organos de costura 成套组件
-1 /01 Teile-Nr. Part No. N° de pieza 零件号	Standard Material Standard material Material estandard 标准缝料	 W PC4185-0A ❶ W PC4185-1A ❷	 W PC6051-0A	 W 3450112500	 W 3450141200	
-1 /11 Teile-Nr. Part No. N° de pieza 零件号	Schweres Material Heavy material Material pesado 厚缝料	 W 34501532A1 ❶ W 34501532A2 ❷	 W 34501532A3	 W PC6049-OH	 W 3450141200	



Europäische Union
Wachstum durch Innovation – EFRE



PFAFF Industriesysteme und Maschinen AG

Hans-Geiger-Str. 12 - IG Nord
D-67661 Kaiserslautern

Telefon: +49-6301 3205 - 0
Telefax: +49-6301 3205 - 1386
E-mail: info@pfaff-industrial.com