

# PFAFF



441R -705/03  
-755/03

Teilleiste

Parts list

Liste de pièces

Lista de piezas



Die Inhaltsübersicht auf Seite 3 gibt einen Überblick über die Aufgliederung der Liste. Alle Teile sind so abgebildet, wie sie in der Maschine funktionsmäßig zusammengehören. Die gestrichelten Abbildungen zeigen, wo die daneben abgebildeten Teile hingehören. Einrahmungen auf den Bildseiten zeigen, aus welchen Einzelteilen sich die Gruppenteile zusammensetzen. Nähwerkzeuge und Apparate sind der Unterklassen-Ausstattung zu entnehmen. Die auf den Bildseiten verwendeten Schlüsselzeichen (  ;  ;  usw.) sind in Register "A - 99" erläutert.

Konstruktionsänderungen vorbehalten.



**Achtung!**

Wir machen ausdrücklich darauf aufmerksam, daß Ersatz- und Zubehörteile, die nicht von uns geliefert werden, auch nicht von uns geprüft und freigegeben sind. Der Einbau und / oder die Verwendung solcher Produkte kann daher u. Umständen konstruktiv vorgegebene Eigenschaften Ihrer Maschine negativ verändern. Für Schäden, die durch die Verwendung von Nicht-Originalteilen entstehen, übernehmen wir keine Haftung!



For the various sections of this catalogue, please refer to the "Contents" on page 3. The parts are illustrated as they belong together in the machine. The dashed illustrations show where the adjacent parts belong. The framed-in sections on the illustration pages show the individual parts comprising a group. For gauge parts and attachments please refer to the subclass listing. The keys used on the illustration pages (  ;  ;  etc.) are listed and explained in section "A - 99".

Subject to alterations in design.



**Caution!**

We warn you expressively that spare parts and accessories that are not supplied by us are not tested and released by us. Fitting or using these products may therefore have negative influences on features that depend on the machine design. We are not liable for any damage caused by the use of non-Pfaff parts.



La table des matières, page 3, donne un aperçu de la subdivision de la liste. Les pièces figurent sur l'illustration comme elles vont ensemble. Les figures en tirets montrent le lieu de montage des pièces figurant à côté. Les parties encadrées sur les pages à illustrations représentent les pièces individuelles formant groupe. Pour les organes de couture et les appareils, veuillez vous référer à la fiche équipement de sous-classes. Les symboles (  ;  ;  etc.) utilisés sur les pages illustrées sont regroupés et expliqués au registre "A - 99".

Sous réserve de modifications.



**Attention!**

Nous attirons expressément votre attention sur le fait que les pièces de rechange et accessoires qui n'ont pas été livrés par nous n'ont pas non plus été contrôlés et agréés par nous. C'est pourquoi le montage et/ou l'utilisation de telles pièces peut éventuellement entraîner l'altération des caractéristiques de construction de votre machine. Par conséquent, nous n'assumons aucune responsabilité pour les dommages causés par l'emploi de pièces qui ne sont pas d'origine!

En la página 3, bajo el título "contenido", puede verse un resumen de la división de la "lista de piezas". Las piezas están ilustradas conforme se hallan montadas en la máquina. Las figuras a base de líneas entrecortadas muestran dónde y cómo van montadas las piezas ilustradas al lado. Los recuadros en las páginas ilustradas indican las piezas individuales de que se componen los grupos. Para los órganos de costura y aparatos, véase la "Composición de las subclases". Los símbolos clave (  ;  ;  etc.) utilizados en las páginas ilustradas se hallan recopilados y explicados en el registro "A - 99".

Salvo modificaciones técnicas.



**¡Atención!**

Se hace observar que en el caso de piezas de recambio y accesorios que no hayan sido suministrados por nosotros, quiere decir que no han sido sometidas por nuestra parte a un control y que no se les ha dado el visto bueno. Por esta razón, el montaje y/o empleo de tales productos puede repercutir negativamente en las características constructivas previstas en su máquina. ¡Para los daños que eventualmente pudiesen presentarse al utilizar piezas no originales, no asumimos ninguna garantía!

Erläuterung der Schlüsselzeichen  
Explanation of codes  
Explication des codes  
Explicaciones de los códigos

---

Kopf-, Arm-, Grundplatten- und Gehäuseteile  
Needle head parts, arm-, base plate-, and housing parts  
Pièce de tête, bras, plaque fondamentale et carcasse  
Piezas de la cabeza, del brazo, de la placa base y de la carcasa

---

Fadenabschneid-Einrichtung  
Thread trimmer -900/61  
Coupe-fil  
Cortahilos

---

Presserfuß-Automatik  
Automatic presser foot lift -910/15  
Relève-pied automatique  
Alzaprensateclas

---

Wartungseinheit  
Air filter / lubricator -925/03  
Conditionneur d'air comprimé  
Grupo acondicionador del aire comprimido

---

Wartungseinheit  
Air filter / lubricator  
Conditionneur d'air comprimé  
Grupo acondicionador del aire comprimido

---

Zubehörteile, Fadenöler, Einstellehren  
Accessory parts, table of thread-lubricants, Adjustment gauges  
Accessoires, tableau des lubrifiants, calibres  
Accesorios, Tabla de lubricantes, Calibres de ajuste

---

Keilriemenscheiben- und Schmiermitteltabelle  
Table of pulleys and lubricants  
Tableau des poulie pour courroie trapézoïdales et des lubrifiants  
Tabla de poleas para correas trapezoidales y lubricantes

---

Index ( Teilenummern / Seitenzahlen )  
Index ( part numbers / page numbers )  
Index ( numéros de pièces, de pages )  
Index ( números de pieza / números de página )

---

Nähwerkzeuge und Apparate  
Gauge parts and attachments  
Organes de couture et guides  
Organos de costure y aparatos

- A** Ausführung A  
Model A  
Version A  
Tipo A
- B** Ausführung B  
Model B  
Version B  
Tipo B
- B/C** Ausführung B/C  
Model B/C  
Version B/C  
Tipo B/C
- Unterklassenabhängig, Teilenummer siehe Nähwerkzeuge und Apparate.  
Subclass-dependent, for part number see gauge parts and attachments.  
Fonction de la sous-classe; pour le numéro de la pièce, voir "organes de couture et guides".  
Dependientes de la subclase, para el número de pieza véase "órganos de costura y aparatos".
- 2** Markierung (Punkte, Striche oder Zahl) bei Bestellung angeben.  
Marking (dots, strokes or numbers) to be stated on order.  
Préciser les repères (points, traits ou chiffres) à la commande.  
Señales (puntos, rayas o cifras), indiquese en los pedidos.
- 3/1** Gesichert mit Loctite.  
Secured with Loctite.  
Bloqué par Loctite.  
Asegurado con Loctite.
- 4** Ausführungsart bei Bestellung angeben.  
Model to be stated on order.  
Préciser le modèle à la commande.  
Indíquese el tipo en los pedidos.
- 6** Nadeldicke und Spitzenform bei Bestellung angeben.  
Needle size and style of point to be stated on order.  
Préciser la grosseur de l'aiguille et la forme de la pointe à la commande.  
Grosor de aguja y forma de la punta, indiquese en los pedidos.
- 28** Sonderausführung  
Special version  
Version spéciale  
Tipo especial

32

Beim Einbau dieses Teiles wird für die Paßgenauigkeit zum Anschlußteil keine Garantie übernommen; zweckmäßig vollständiges Aggregat bestellen.  
No guarantee is assumed that this part will fit the mating part; it is best to order a complete assembly.  
Aucune garantie ne pourra être assurée quant à la précision d'ajustage de cette pièce avec la pièce correspondante; il est indiqué de commander un mécanisme complet.  
Al montar esta pieza no se asume garantía alguna en cuanto a la tolerancia y precisión de ajuste respecto a la pieza correspondiente; por esta razón, se recomienda pedir el grupo completo.

32/1

Beim Einbau dieses Teiles ist Nacharbeit erforderlich.  
When fitting this part re-work is required.  
Retouches nécessaires au montage.  
Al montar esta pieza hay que retocarla antes.

40/2

Tränken mit 280-1-120 144; Bestellnummer siehe Seite 40.  
Soak with 280-1-120 144; for part number see page 40.  
Imbiber d'huile 280-1-120 144; n° de commande, voir page 40.  
Empape con aceite 280-1-120 144; para el número de pedido véase la página 40.

40/3

Fetten mit 280-1-120 247; Bestellnummer siehe Seite 40.  
Grease with 280-1-120 247; for part number see page 40.  
Graisser avec de la graisse 280-1-120 247; n° de commande, voir page 40.  
Engrase con grasa 280-1-120 247; para el número de pedido véase la página 40.

40/4

Fetten mit 280-1-120 243; Bestellnummer siehe Seite 40.  
Grease with 280-1-120 243; for part number see page 40.  
Graisser avec de la graisse 280-1-120 243; n° de commande, voir page 40.  
Engrase con grasa 280-1-120 243 para el número de pedido véase la página 40.

40/6

Füllen mit 280-1-120 217, Bestellnummer siehe Seite 40.  
Top up with 280-1-120 217; for part number see page 40.  
Remplir de 280-1-120 217; n° de commande, voir page 40.  
Rellene con 280-1-120 217; para el número de pedido véase la página 40.

40/13

Fetten mit 280-1-120 205; Bestellnummer siehe Seite 40.  
Grease with 280-1-120 205; for part number see page 40.  
Graisser avec de la graisse 280-1-120 205; n° de commande, voir page 40.  
Engrase con grasa 280-1-120 205; para el número de pedido véase la página 40.

70/1

Rollfuß 35mm ø, 4,0 mm breit, gezahnt.  
Roller presser, with 35 mm dia., 4,0 mm wide, toothed.  
Pied à roulette, diamètre 35 mm, largeur 4,0 mm, denté.  
Pie rodante de 35 mm ø, 4,0 de ancho, dentado.

70/2

Rollfuß 35mm  $\varnothing$ , 2,6 mm breit, glatt.  
Roller presser, with 35 mm dia., 2,6 mm wide, smooth.  
Pied à roulette, diamètre 35 mm, largeur 2,6 mm, lisse.  
Pie rodante de 35 mm  $\varnothing$ , 2,6 de ancho, liso.

70/3

Rollfuß 25mm  $\varnothing$ , 4,0 mm breit, gezahnt.  
Roller presser, with 25 mm dia., 4,0 mm wide, toothed.  
Pied à roulette, diamètre 25 mm, largeur 4,0 mm, denté.  
Pie rodante de 25 mm  $\varnothing$ , 4,0 de ancho, dentado.

70/4

Rollfuß 25mm  $\varnothing$ , 2,6 mm breit, gezahnt.  
Roller presser, with 25 mm dia., 2,6 mm wide, toothed.  
Pied à roulette, diamètre 25 mm, largeur 2,6mm, denté.  
Pie rodante de 25 mm  $\varnothing$ , 2,6 de ancho, dentado.

70/5

Rollfuß 25mm  $\varnothing$ , 2,6 mm breit, glatt.  
Roller presser, with 25 mm dia., 2,6 mm wide, smooth.  
Pied à roulette, diamètre 25 mm, largeur 2,6 mm, lisse.  
Pie rodante de 25 mm  $\varnothing$ , 2,6 de ancho, liso.

96

Länge angeben.  
State length.  
Préciser longueur.  
Indiquese la largura.

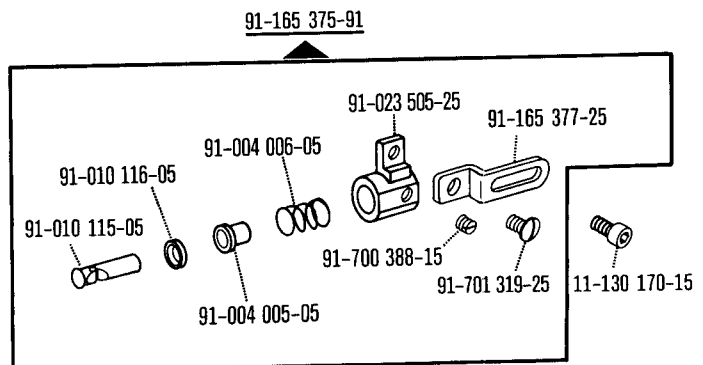
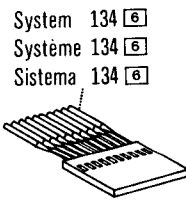
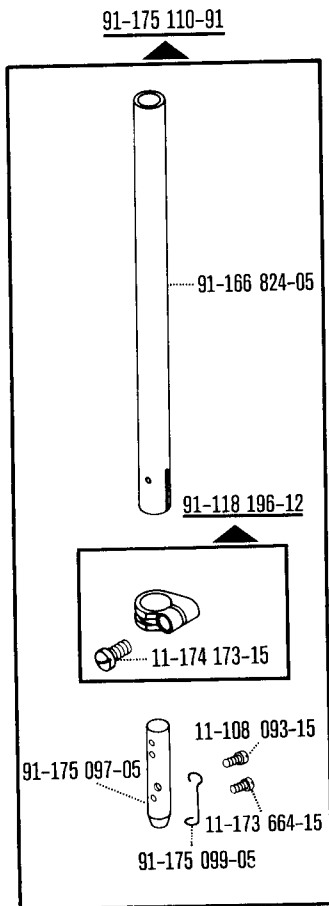
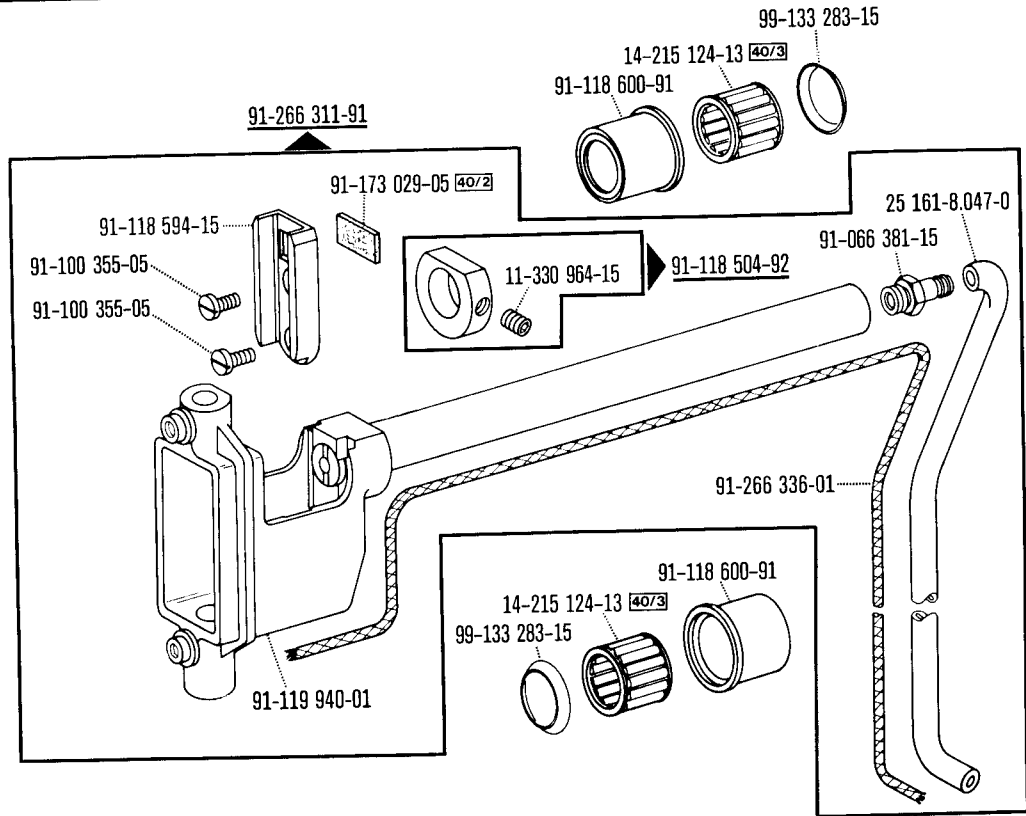

☐ siehe Erläuterungen Register [A] - [99]  
 see explanations in section [A] - [99]  
 voir légende registre [A] - [99]  
 ver explicaciones del registro [A] - [99]

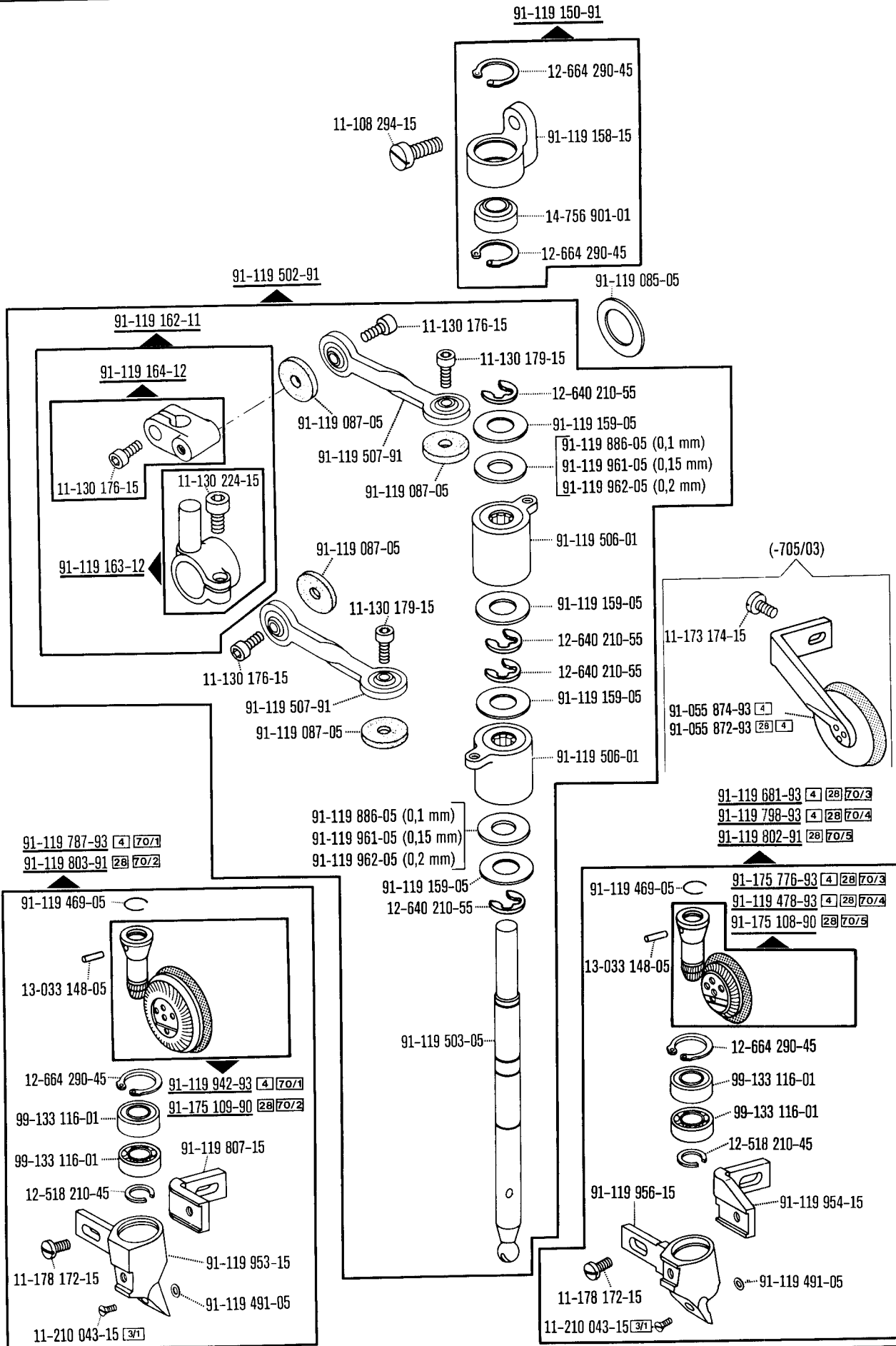

☐ siehe Erläuterungen Register [A] [99]  
 see explanations in section [A] [99]  
 voir légende registre [A] [99]  
 ver explicaciones del registro [A] [99]



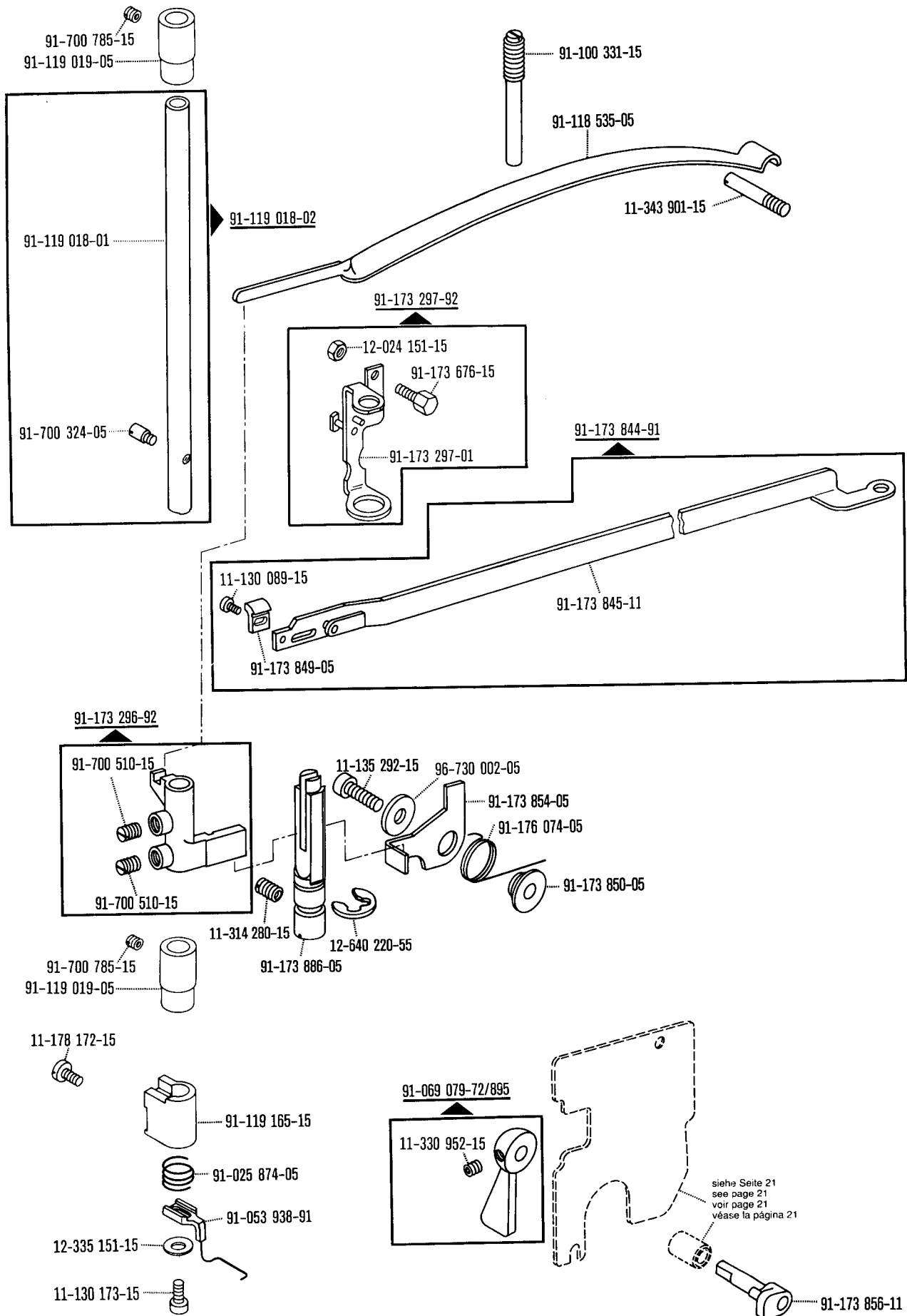

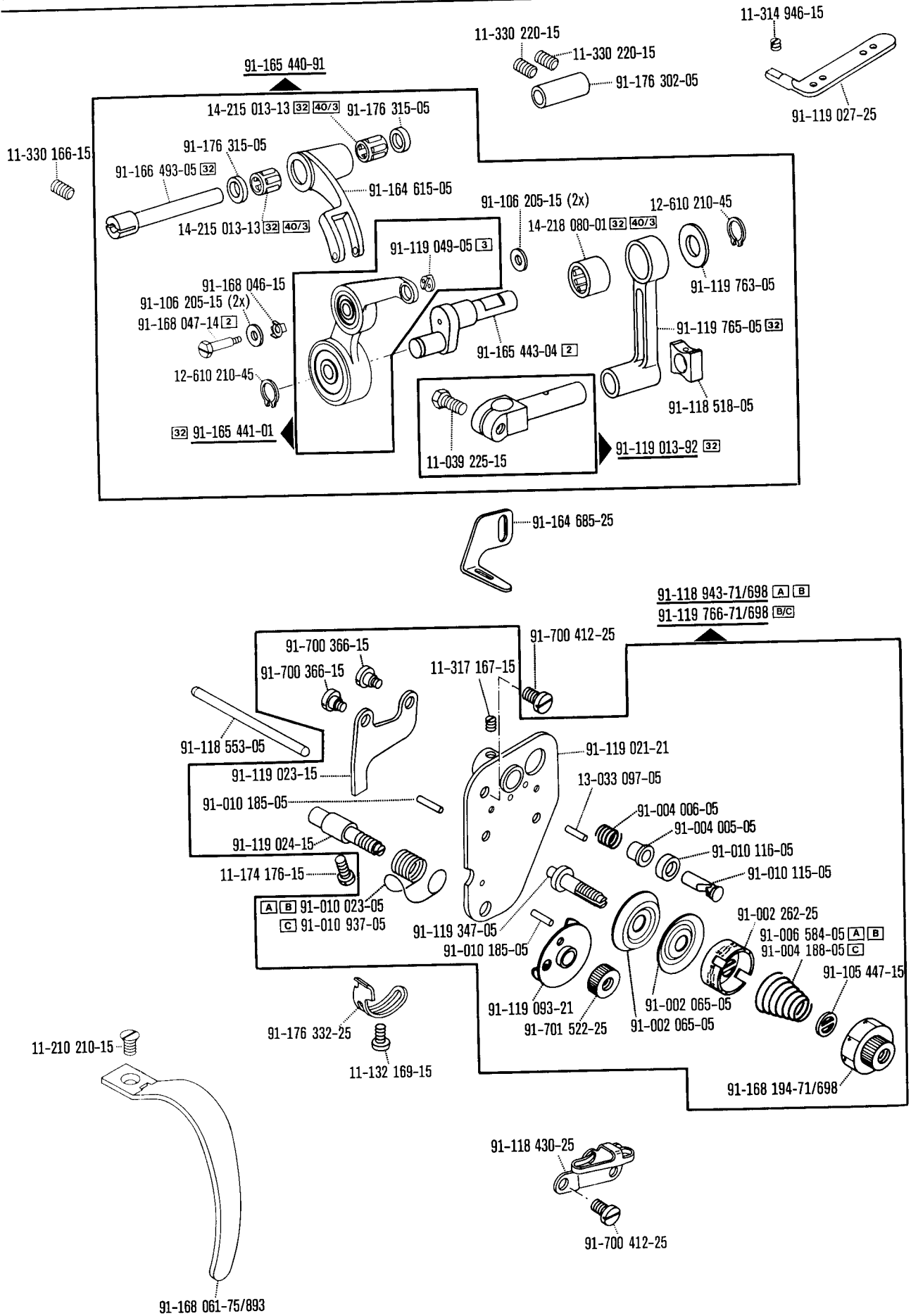

Basisteile  
 Basic parts  
 Pièces de base  
 Piezas básicas

□ siehe Erläuterungen Register [A] [99]  
 see explanations in section [A] [99]  
 voir légende registre [A] [99]  
 ver explicaciones del registro [A] [99]

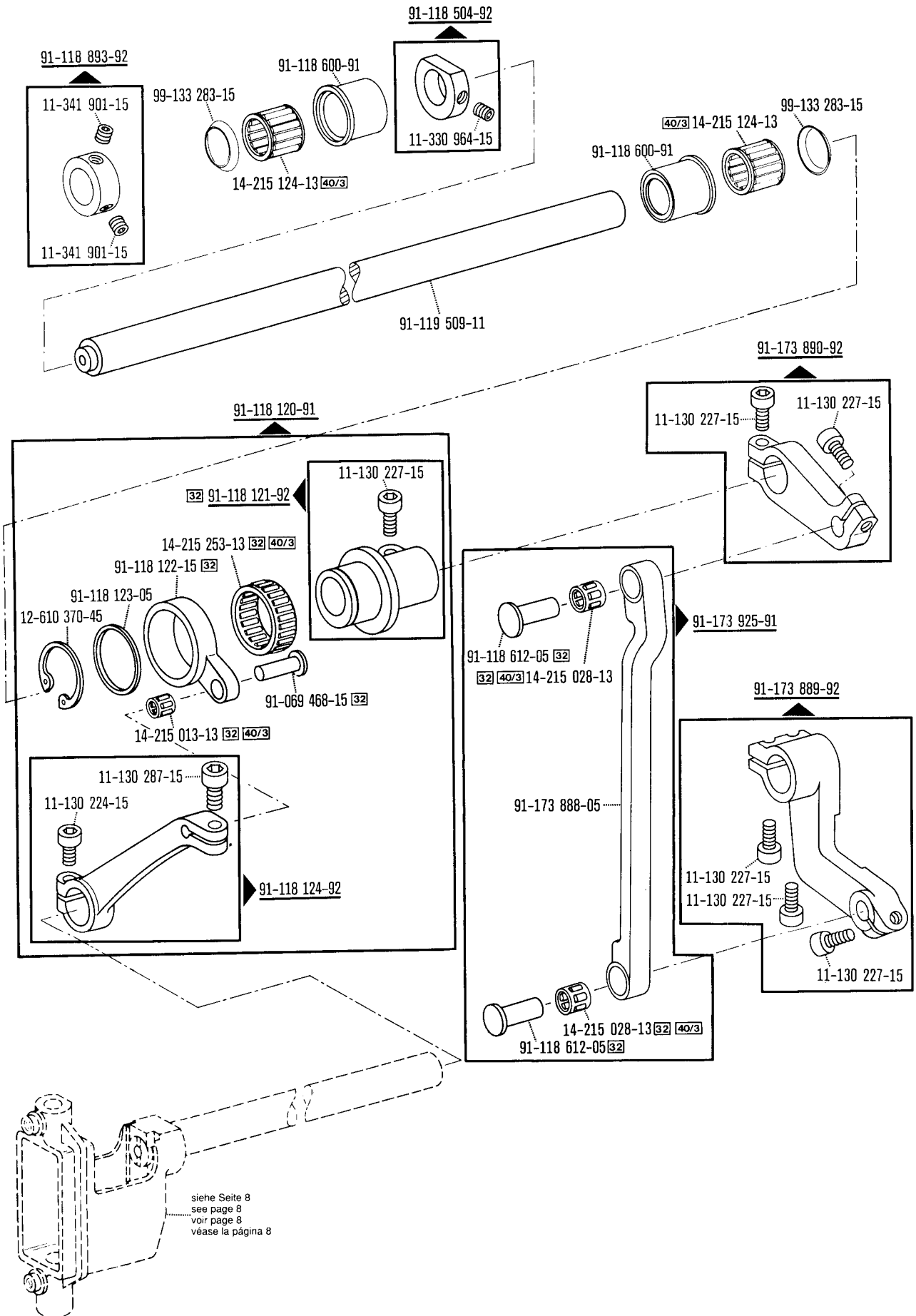

Basisteile  
 Basic parts  
 Pièces de base  
 Piezas básicas

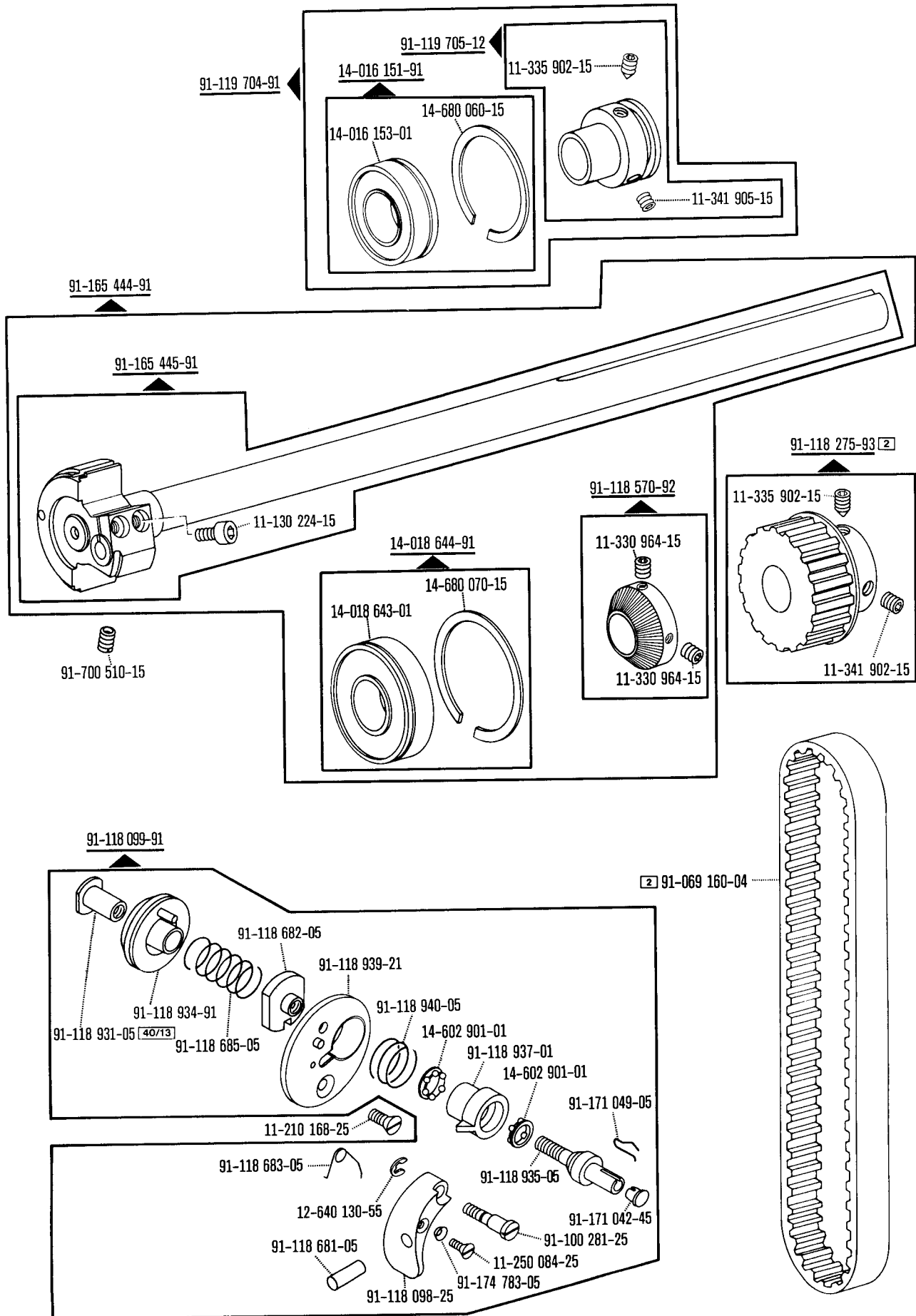

□ siehe Erläuterungen Register **A**-**99**  
 see explanations in section **A**-**99**  
 voir légende registre **A**-**99**  
 ver explicaciones del registro **A**-**99**

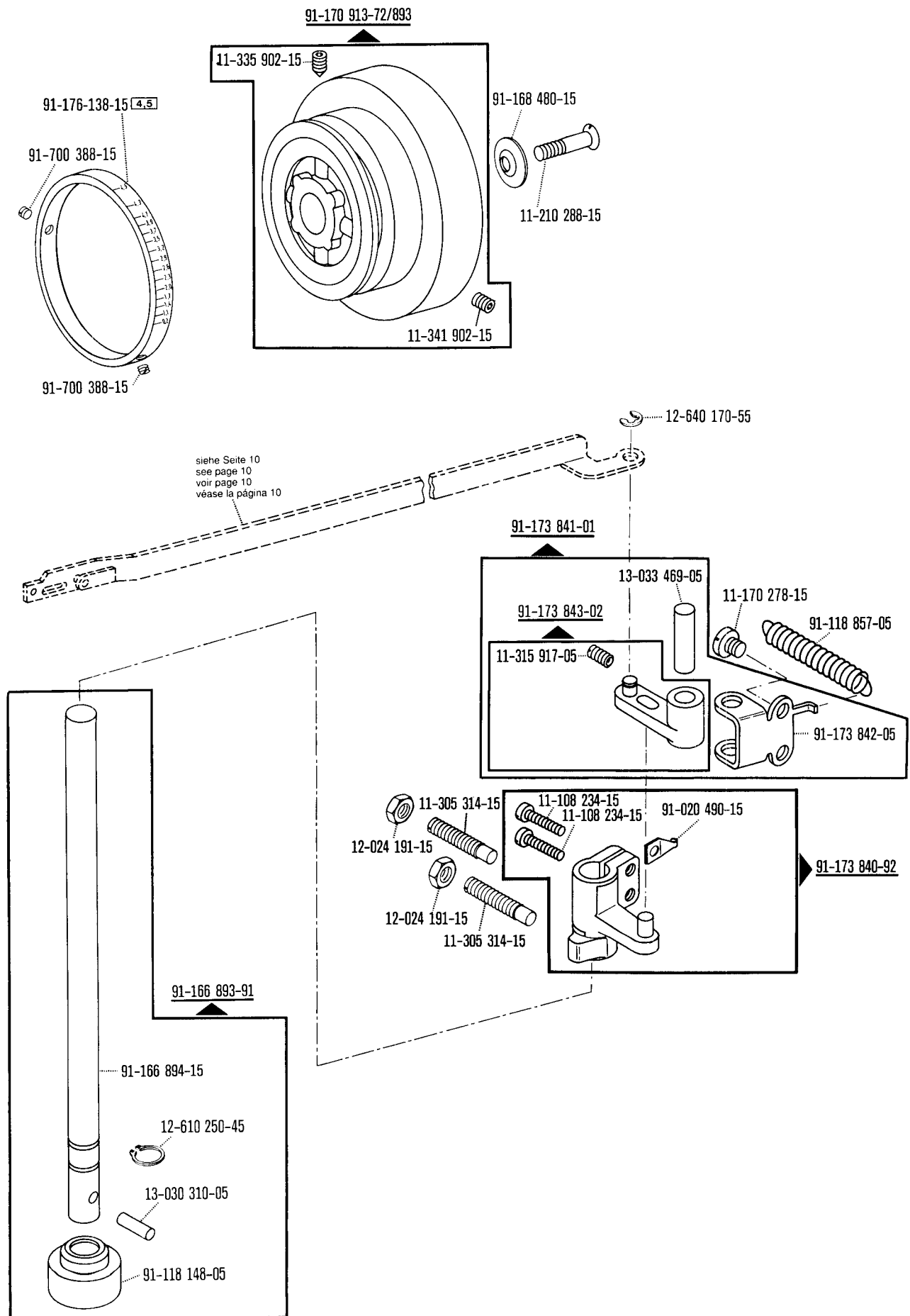

Grundplattenteile  
Bedplate parts  
Pièces du plateau fondamental  
Piezas de la placa-base

PFAFF 441-R-705/03; -755/03

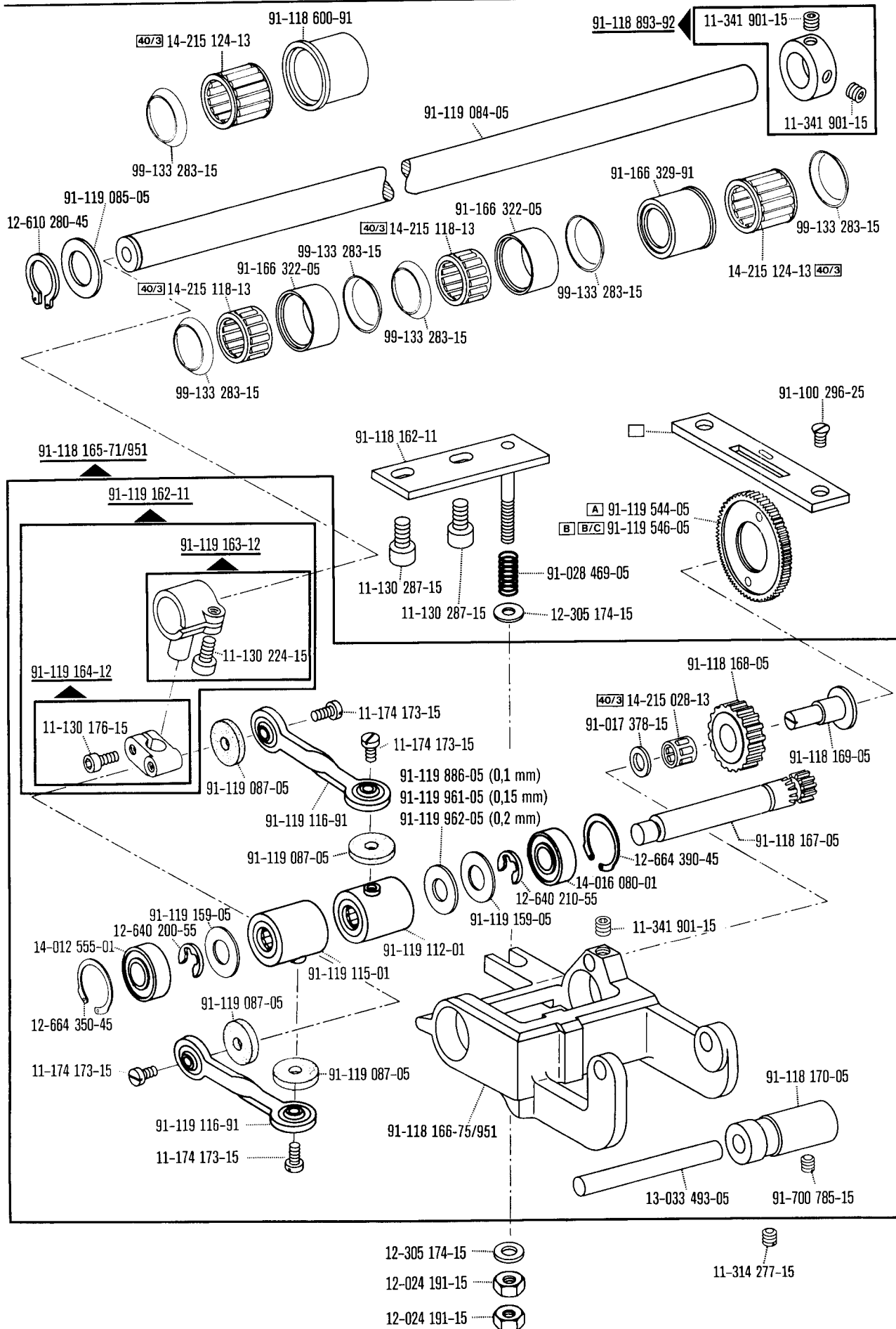

Basisteile  
Basic parts  
Pièces de base  
Piezas básicas

☐ siehe Erläuterungen Register A-99  
see explanations in section A-99  
voir légende registre A-99  
ver explicaciones del registro A-99

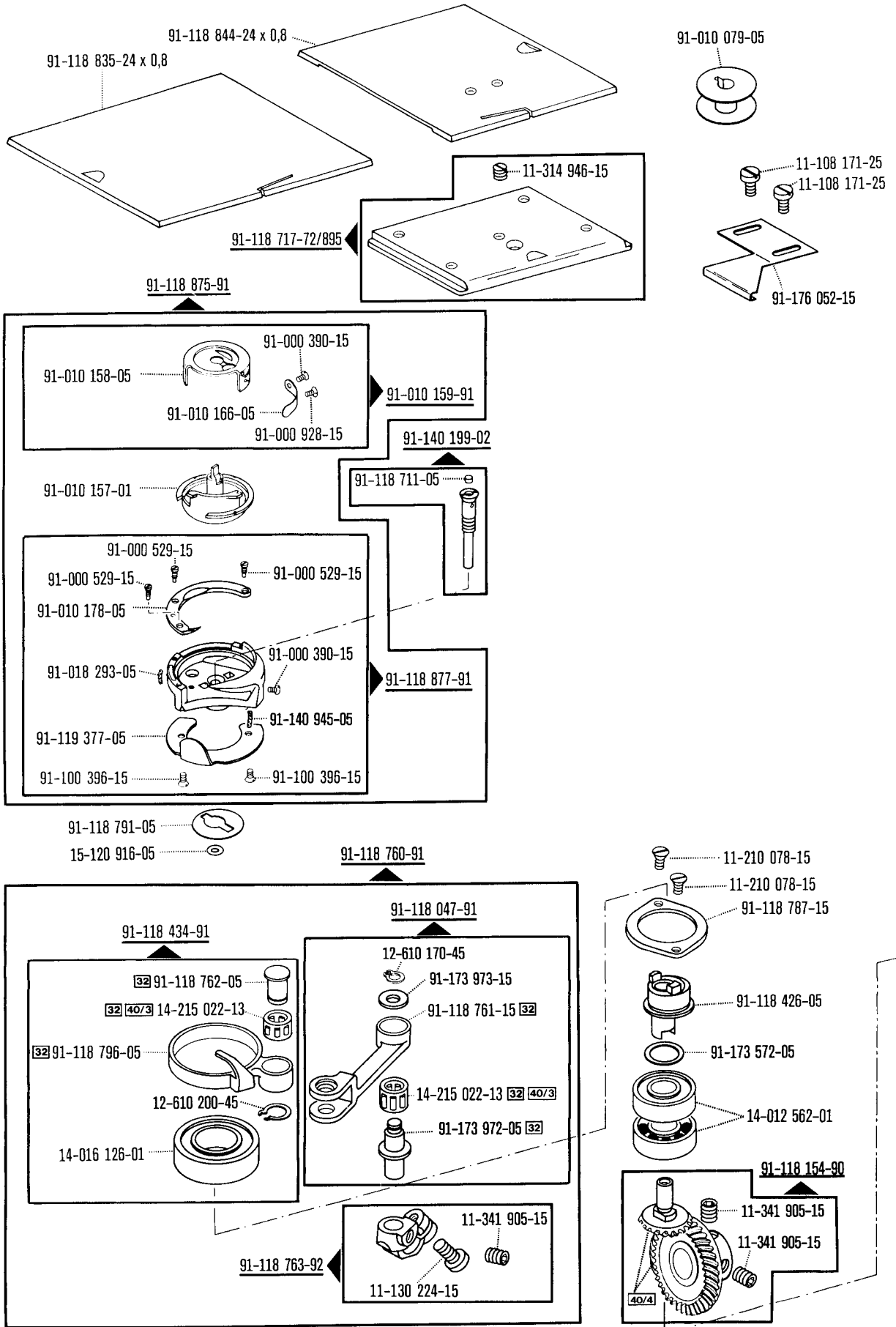

Basisteile  
 Basic parts  
 Pièces de base  
 Piezas básicas

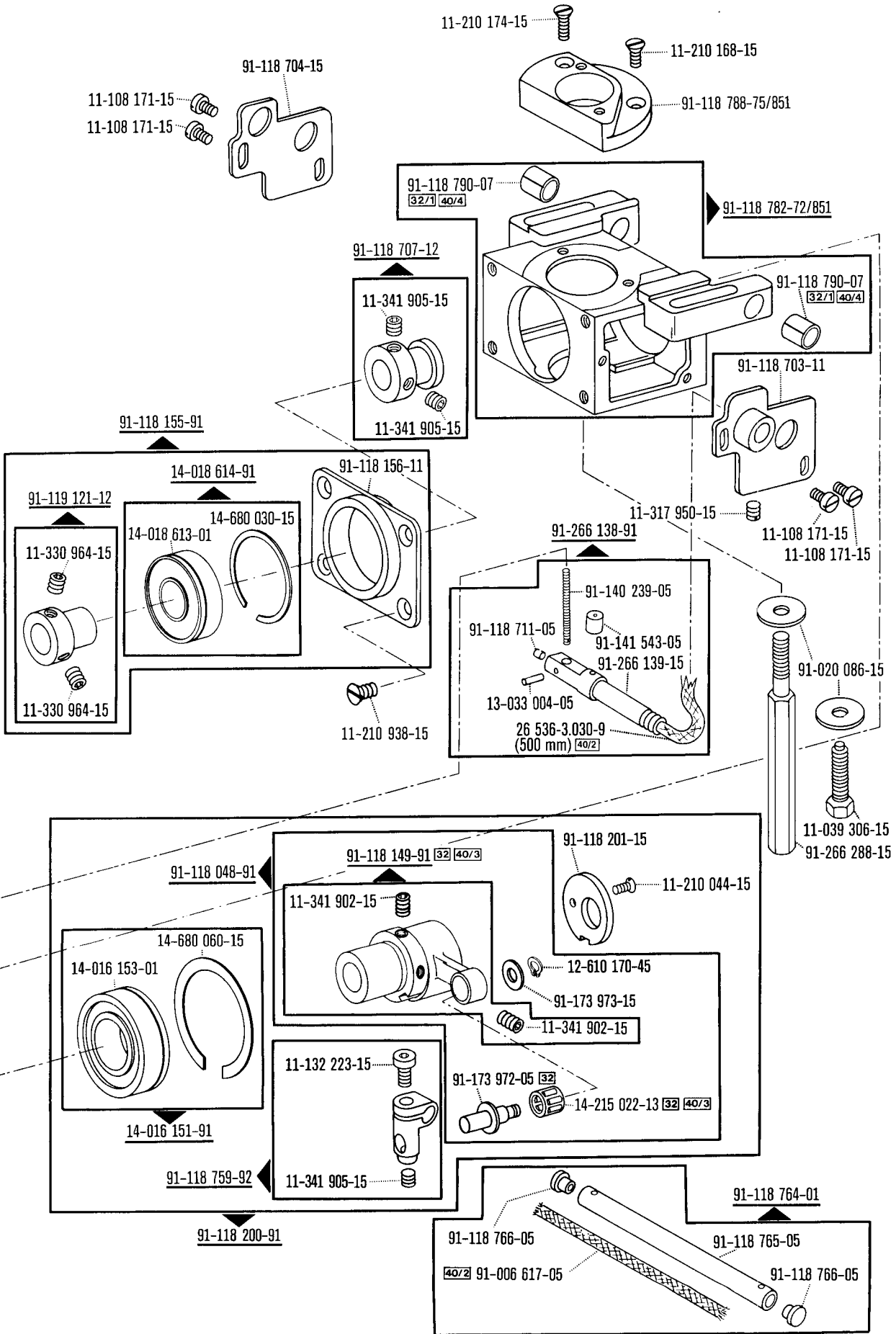

☐ siehe Erläuterungen Register [A]·[99]  
 see explanations in section [A]·[99]  
 voir légende registre [A]·[99]  
 ver explicaciones del registro [A]·[99]



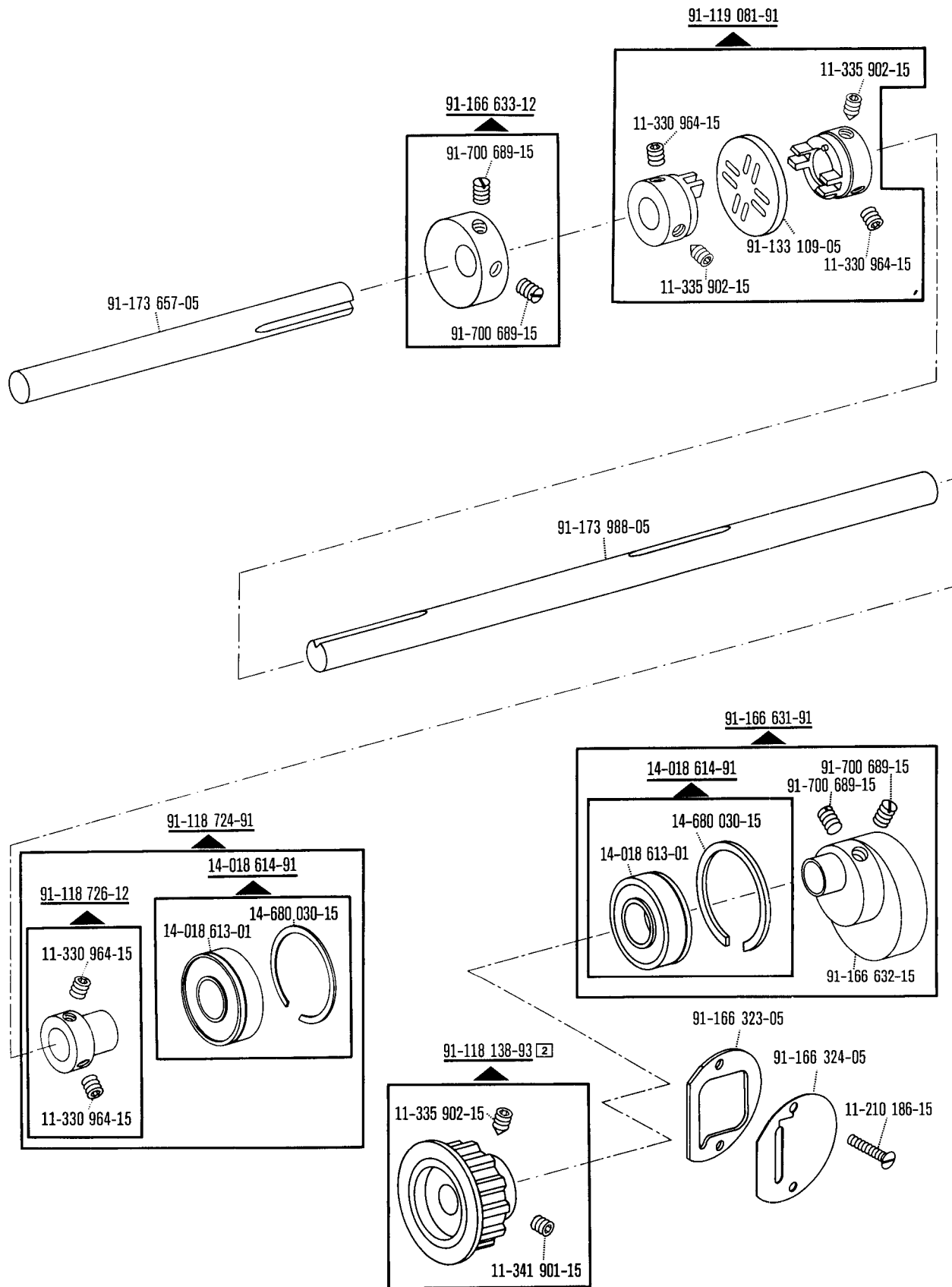

Basisteile  
 Basic parts  
 Pièces de base  
 Piezas básicas

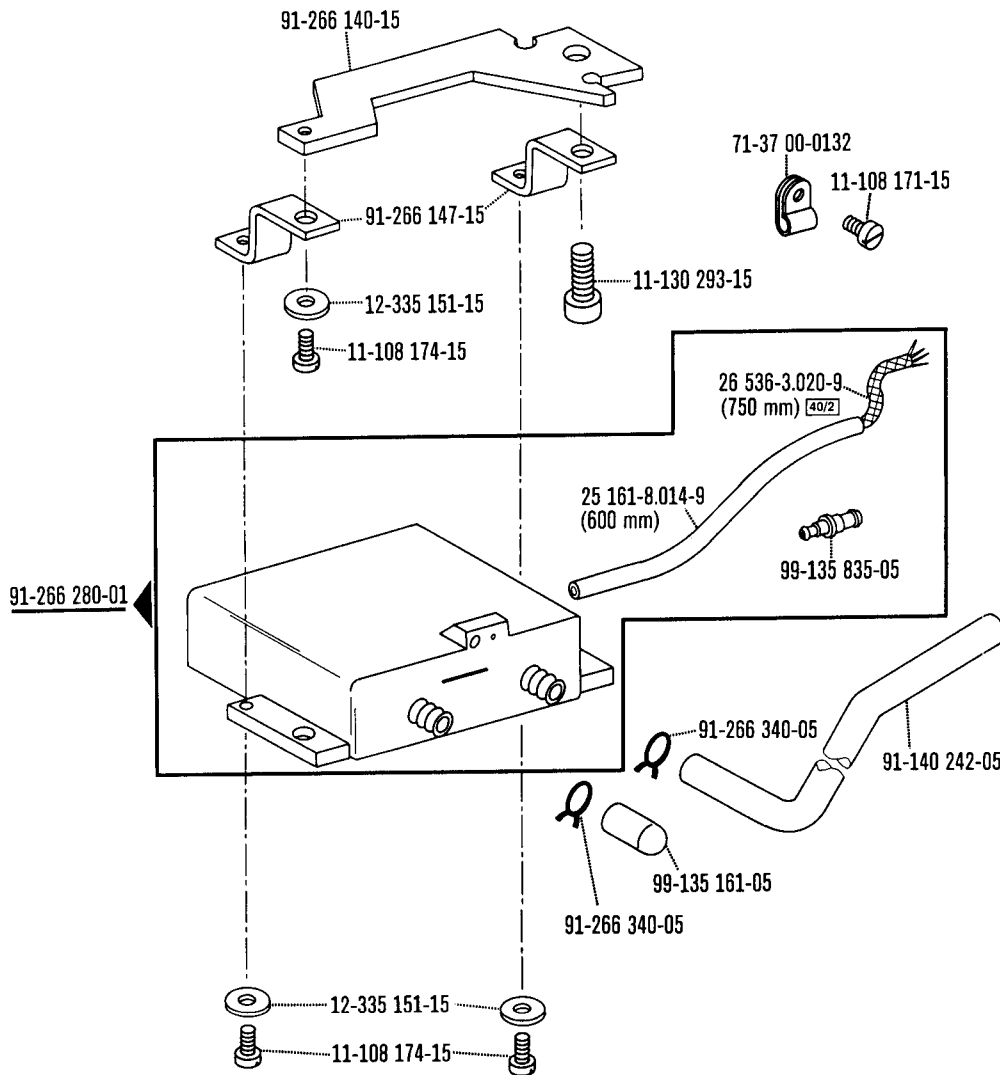

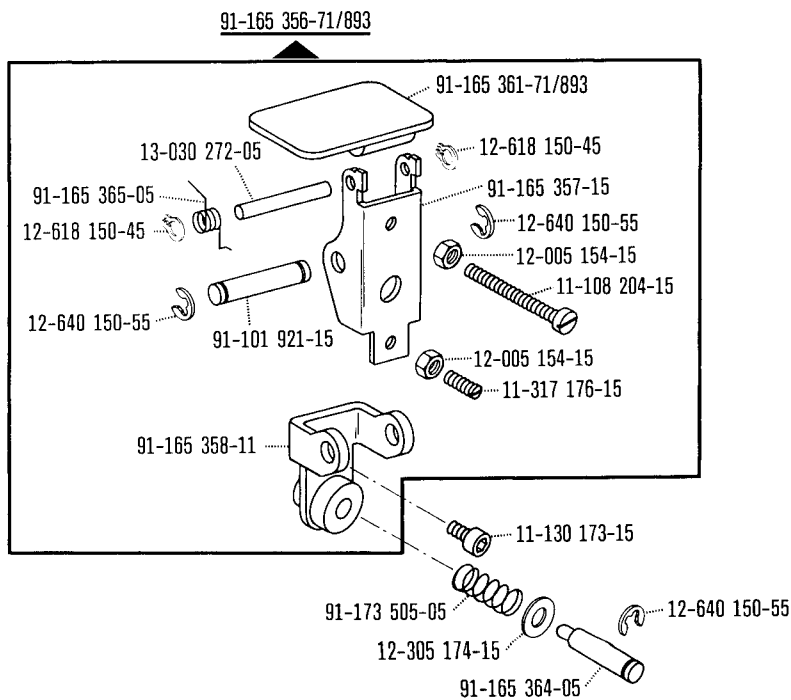
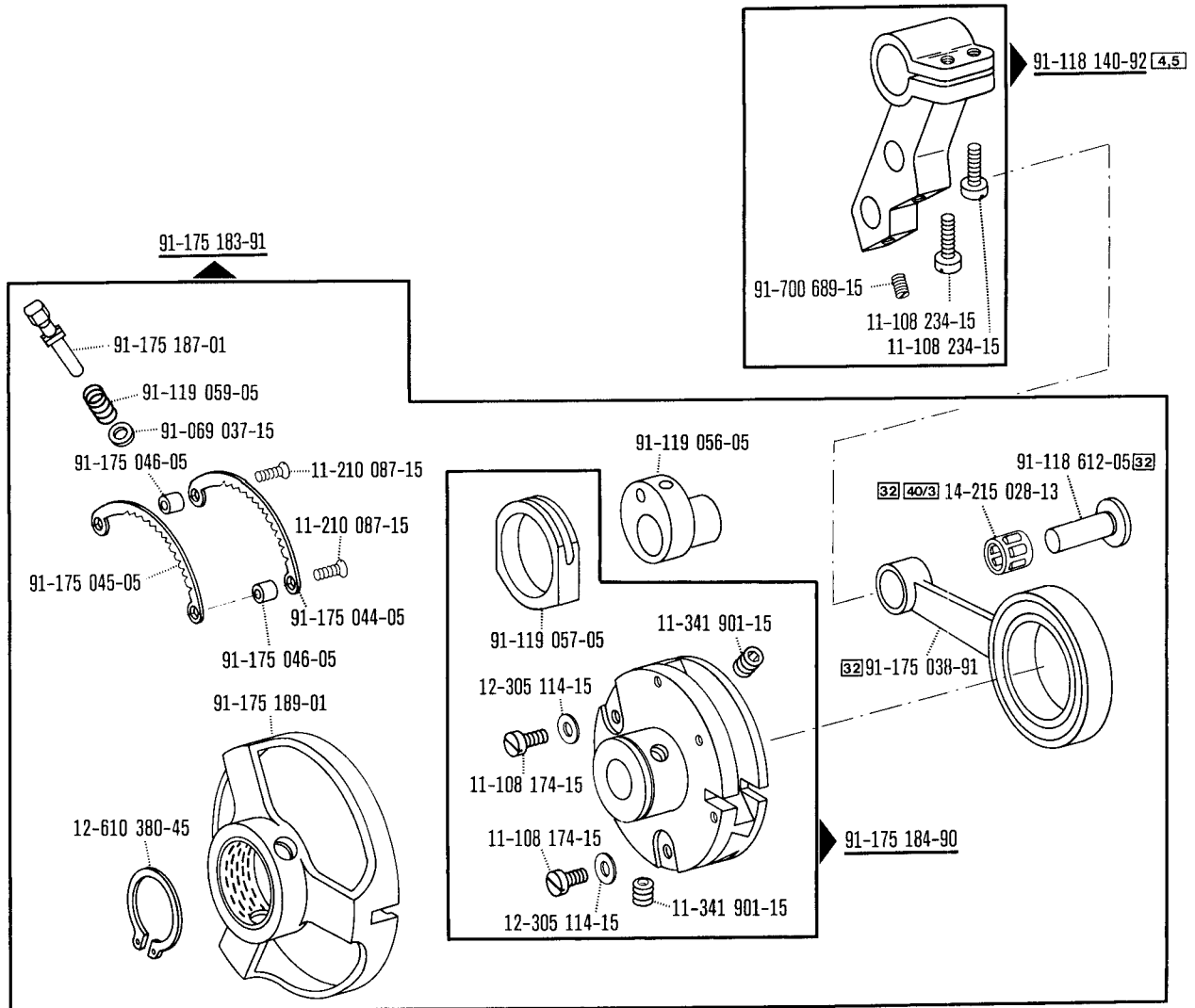

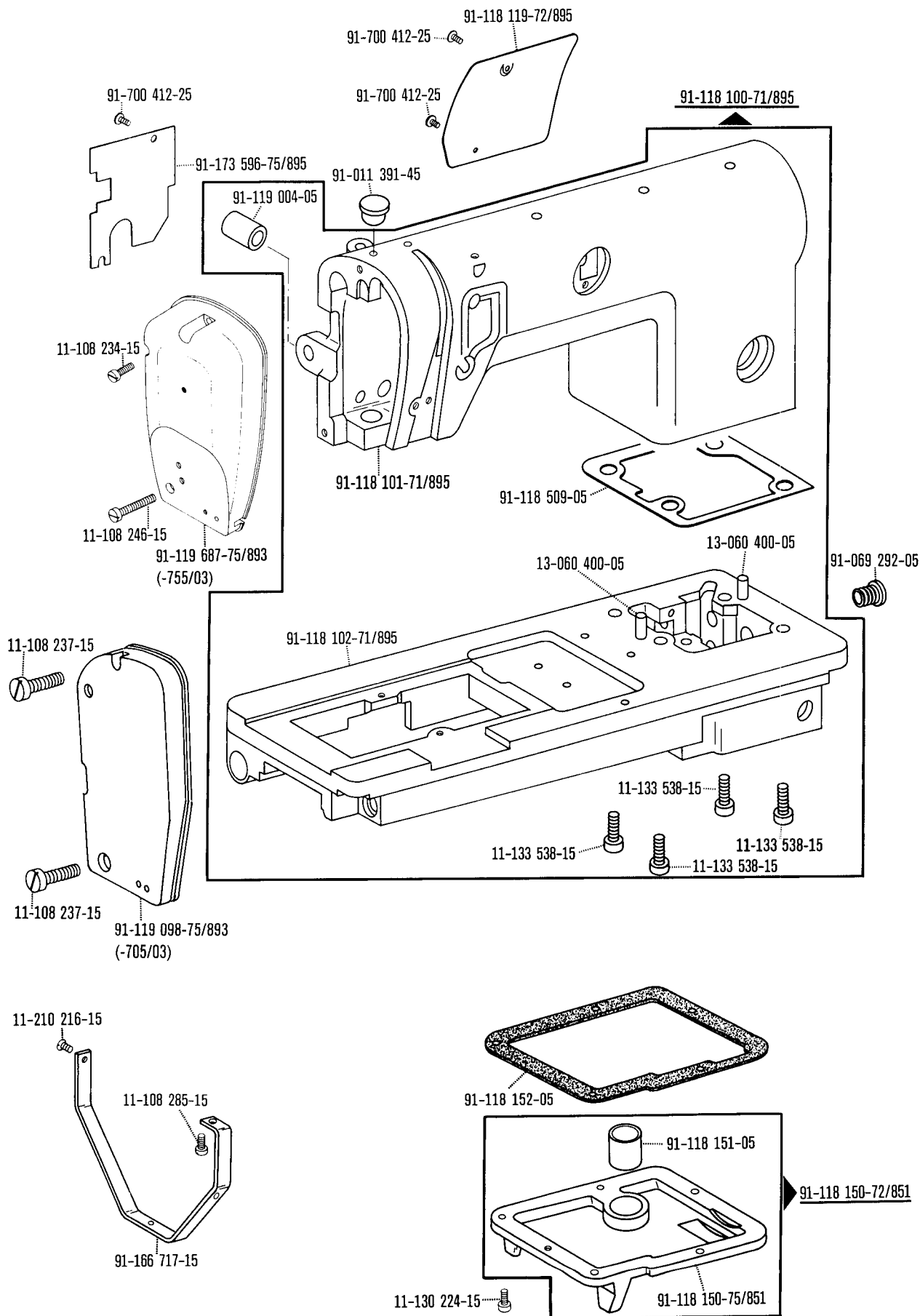

☐ siehe Erläuterungen Register **A** · 99  
see explanations in section **A** · 99  
voir légende registre **A** · 99  
ver explicaciones del registro **A** · 99

-900/..

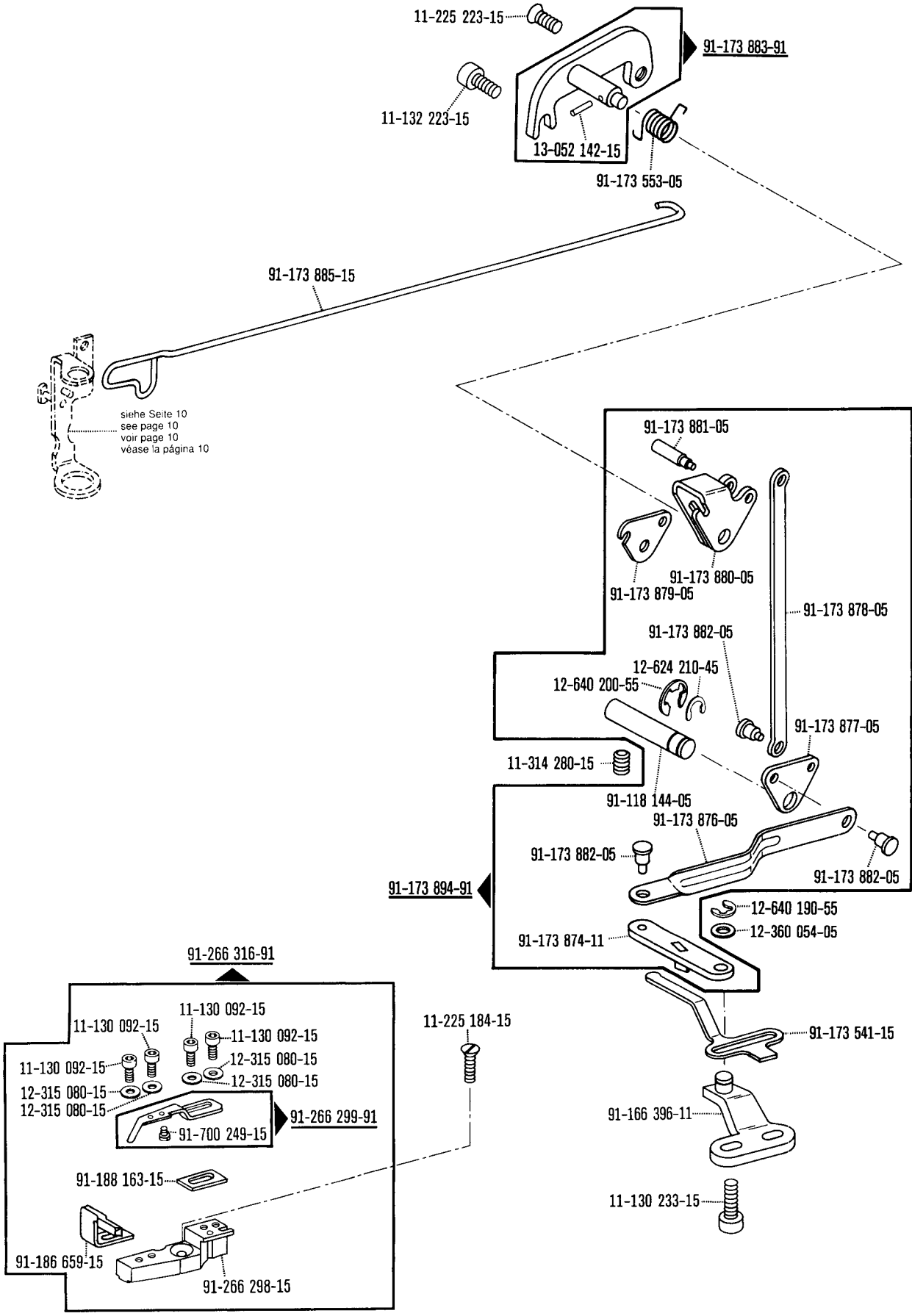

siehe Seite 10  
 see page 10  
 voir page 10  
 véase la página 10

☐ siehe Erläuterungen Register **A** · 99  
 see explanations in section **A** · 99  
 voir légende registre **A** · 99  
 ver explicaciones del registro **A** · 99

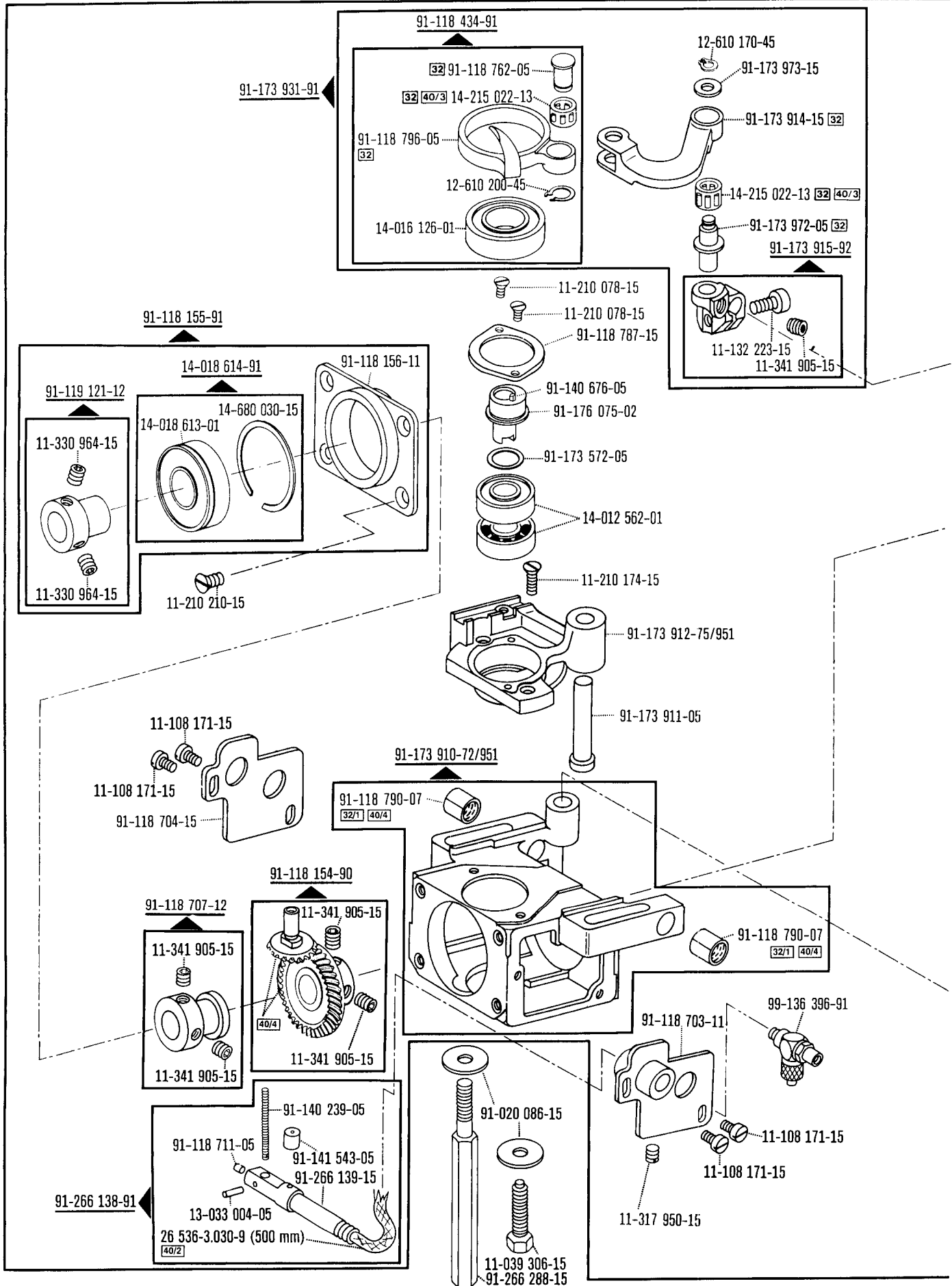

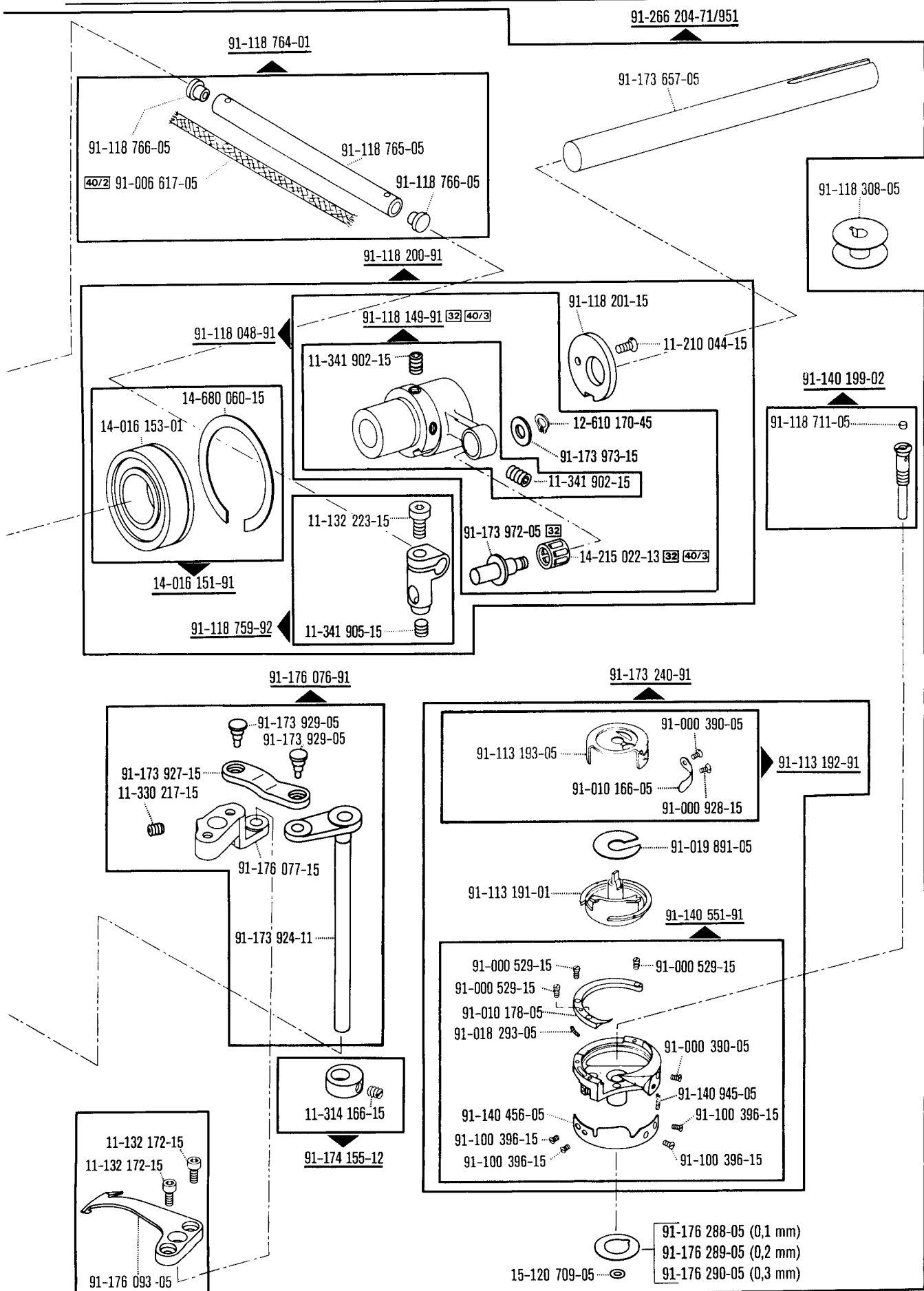

**-900/..**

☐ siehe Erläuterungen Register **A** · **99**  
see explanations in section **A** · **99**  
voir légende registre **A** · **99**  
ver explicaciones del registro **A** · **99**

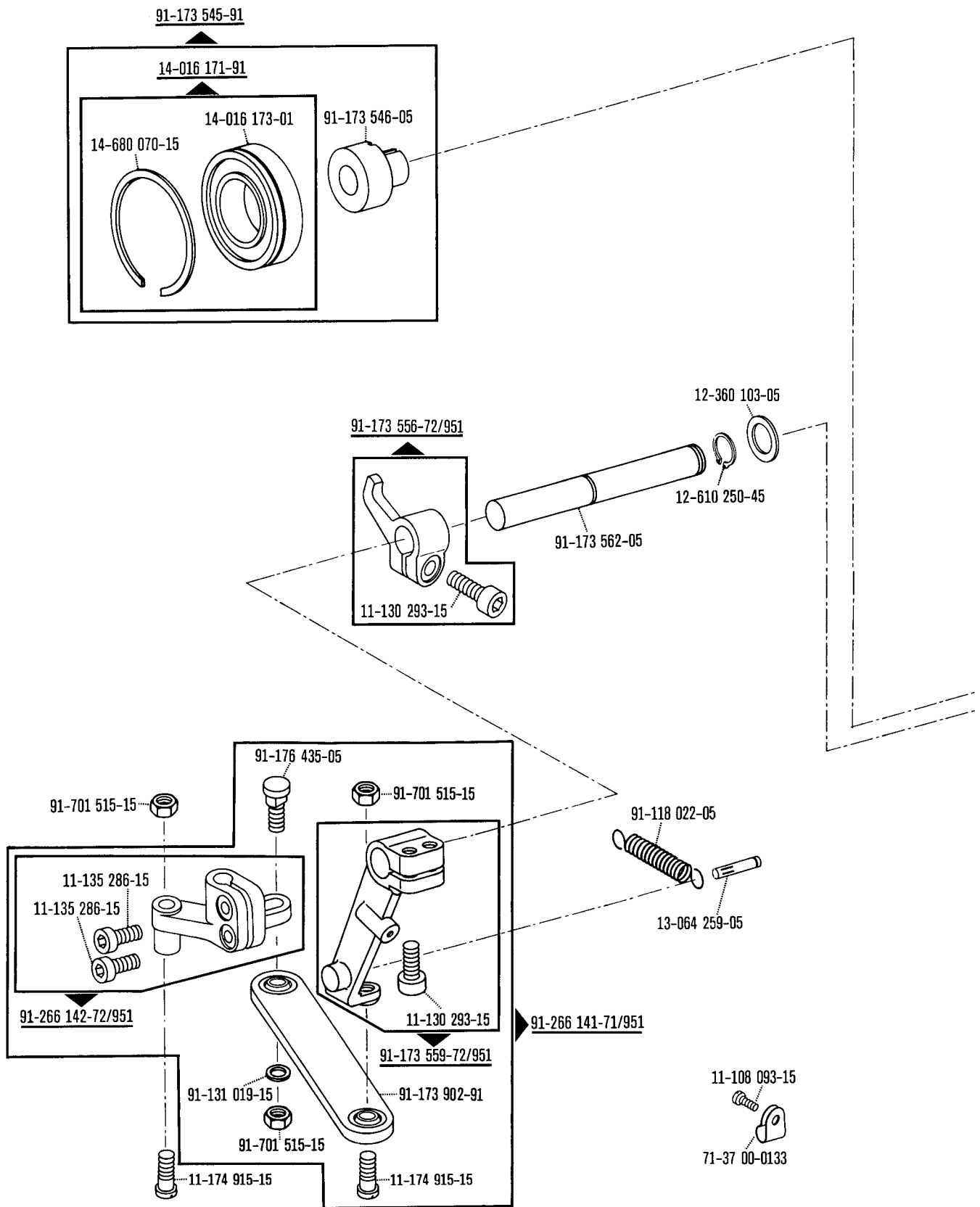



91-176 088-91

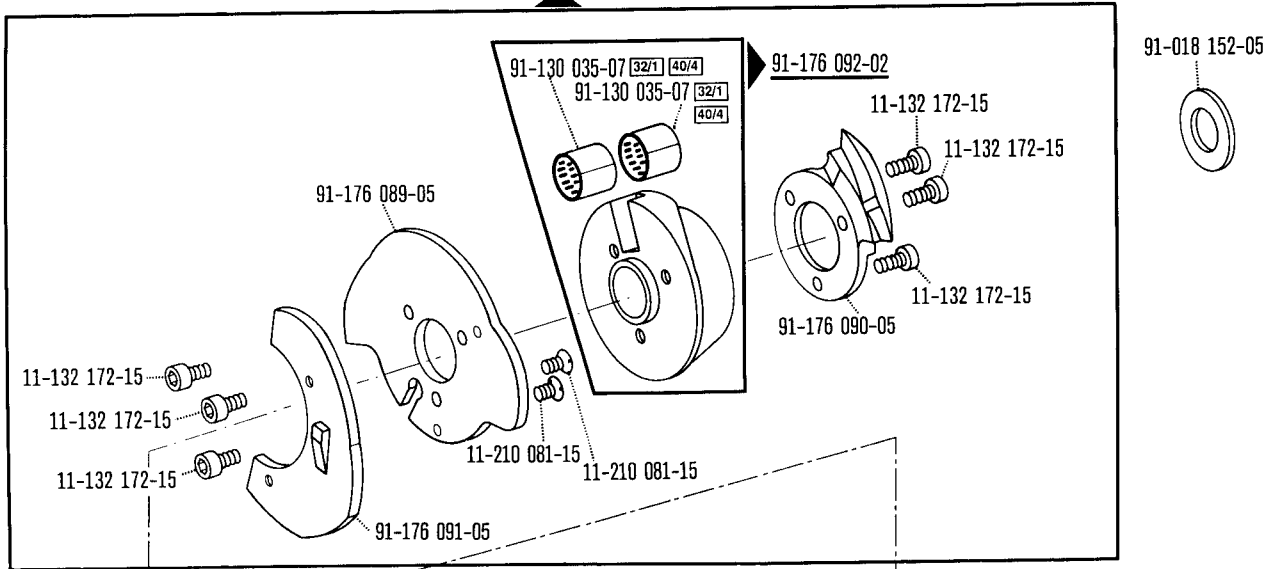

-900/..

91-176 095-91

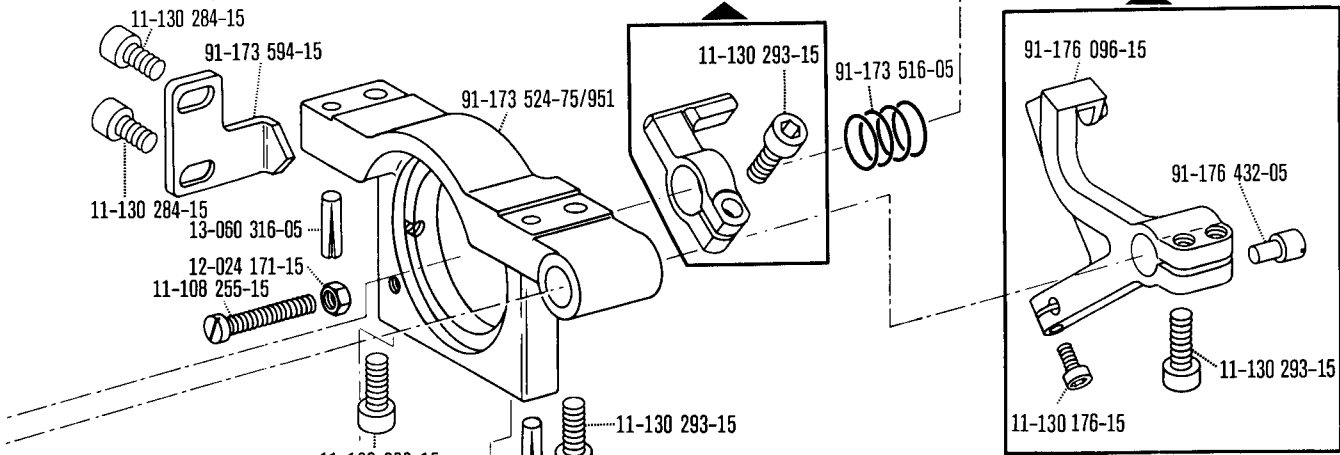

91-173 501-71/951

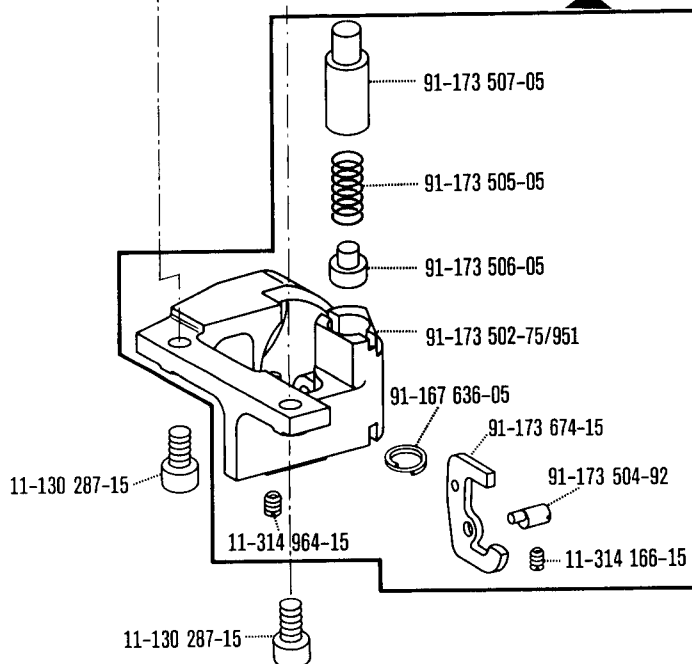

91-090 823-91

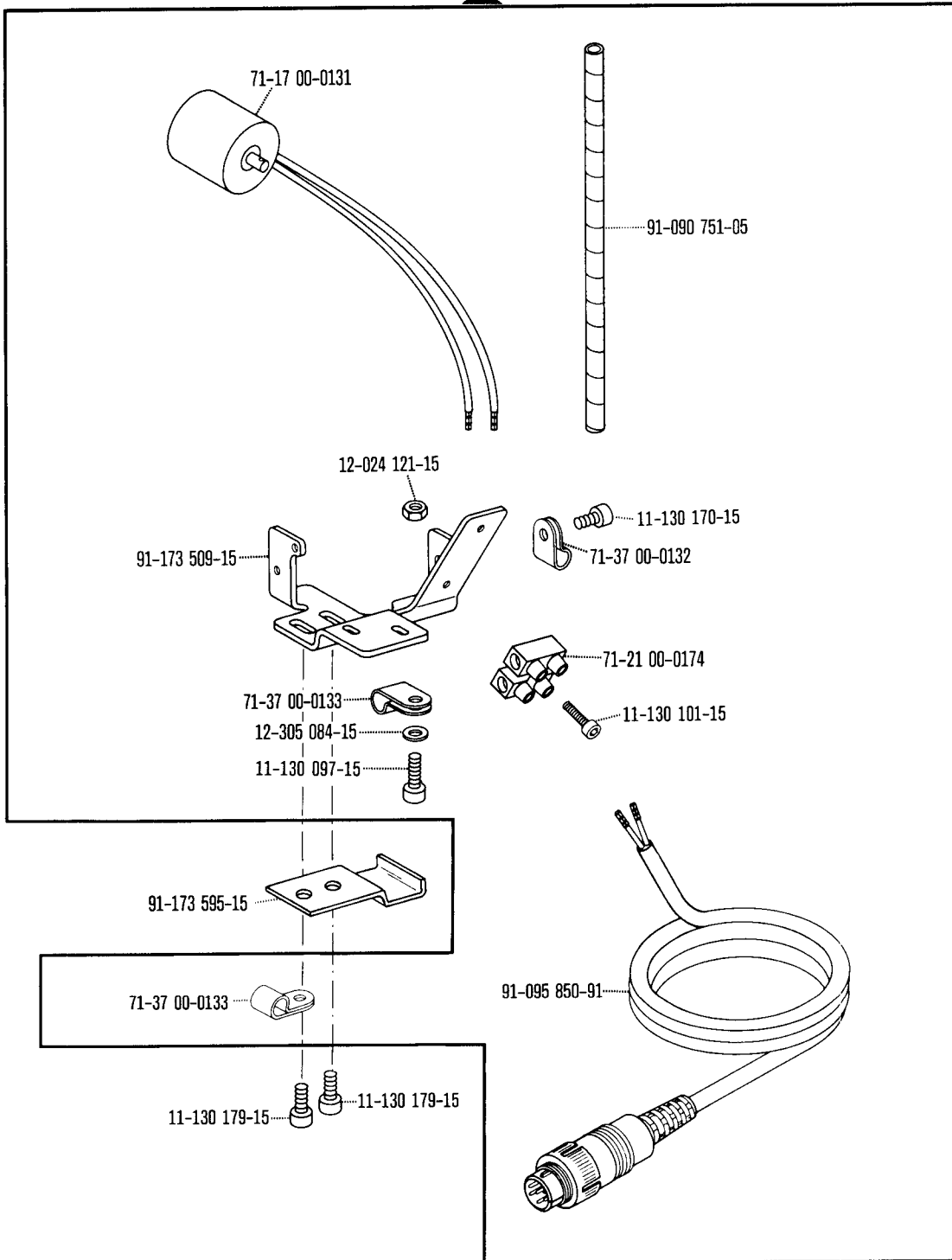

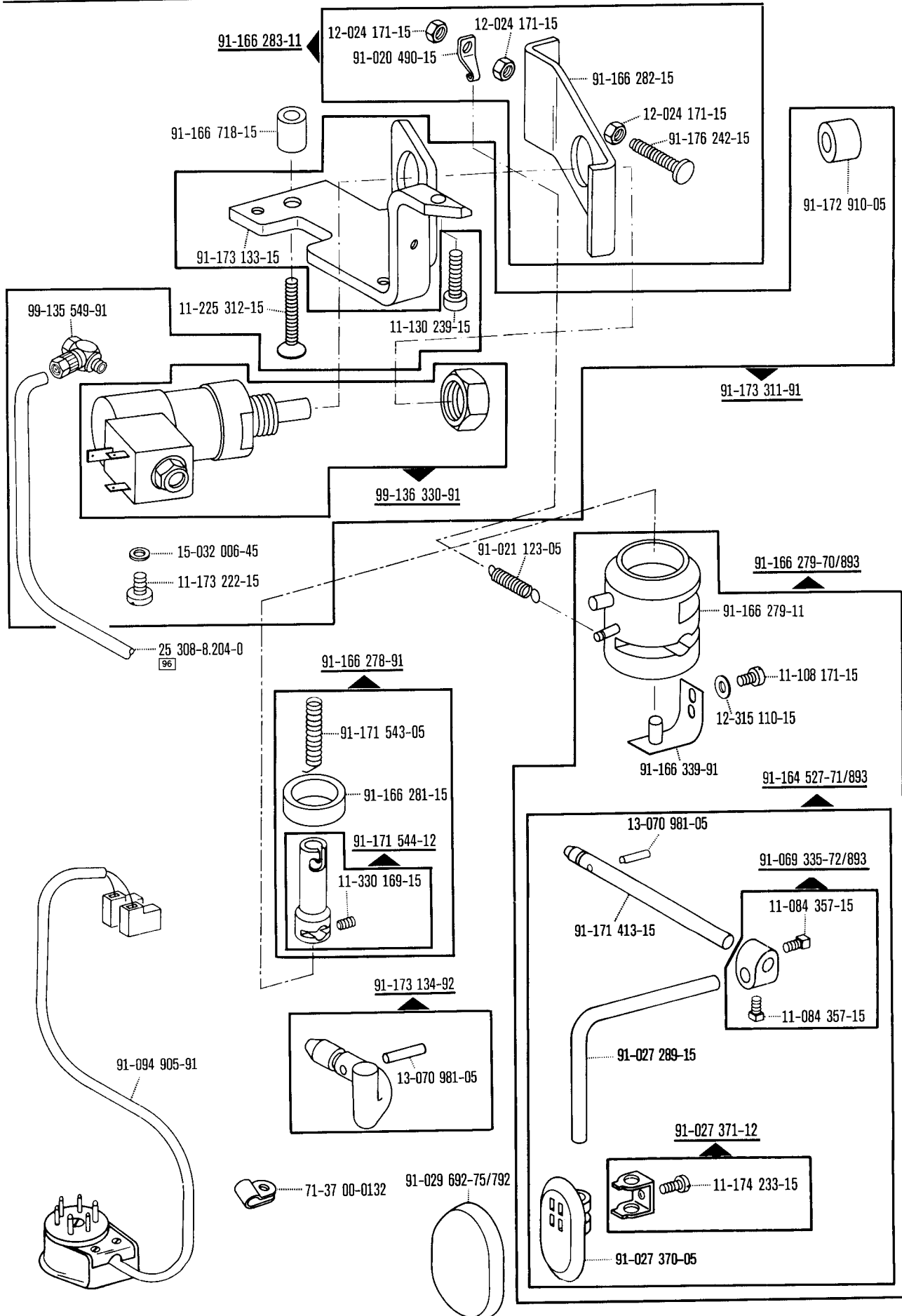

-910/..

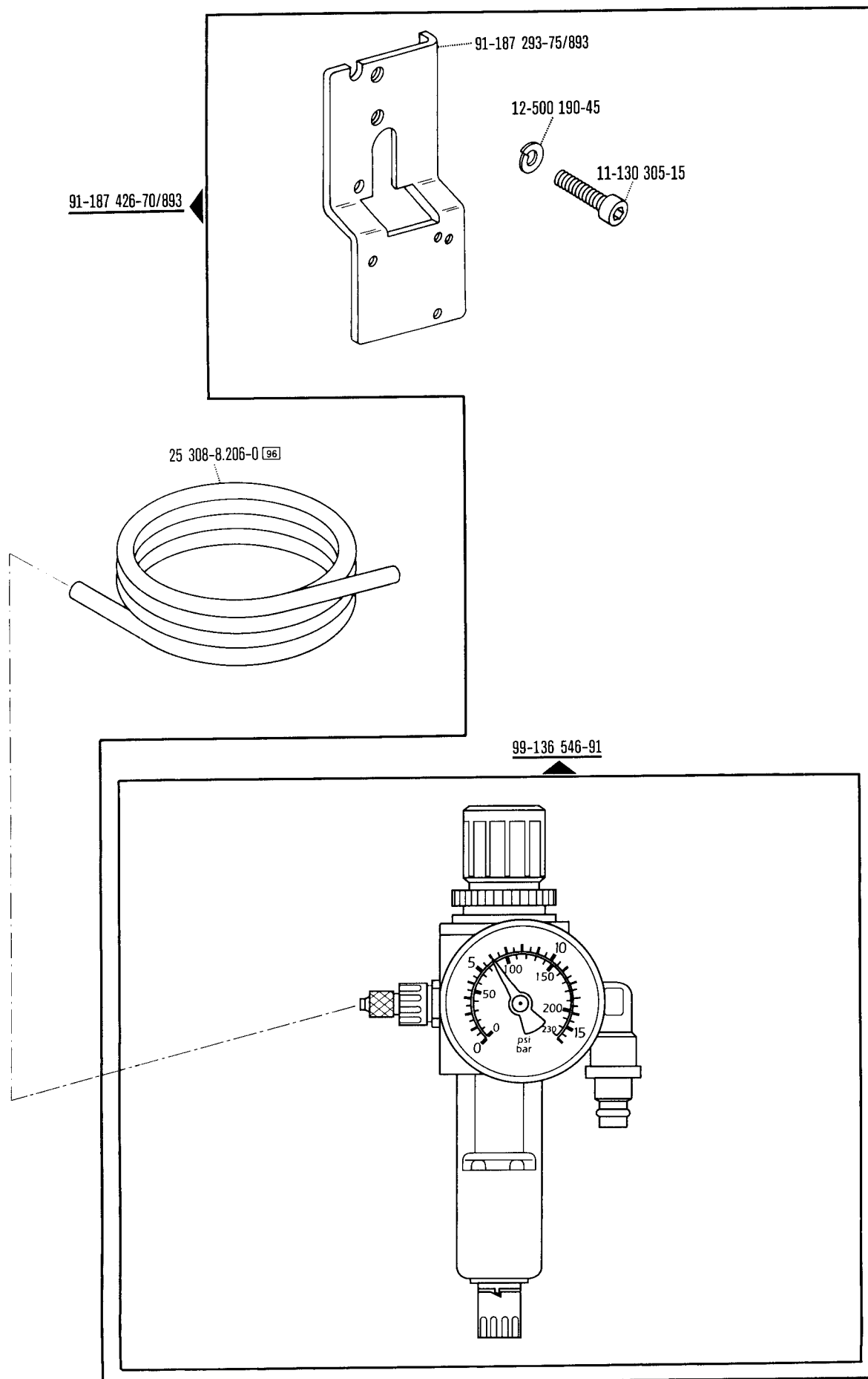

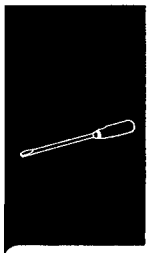
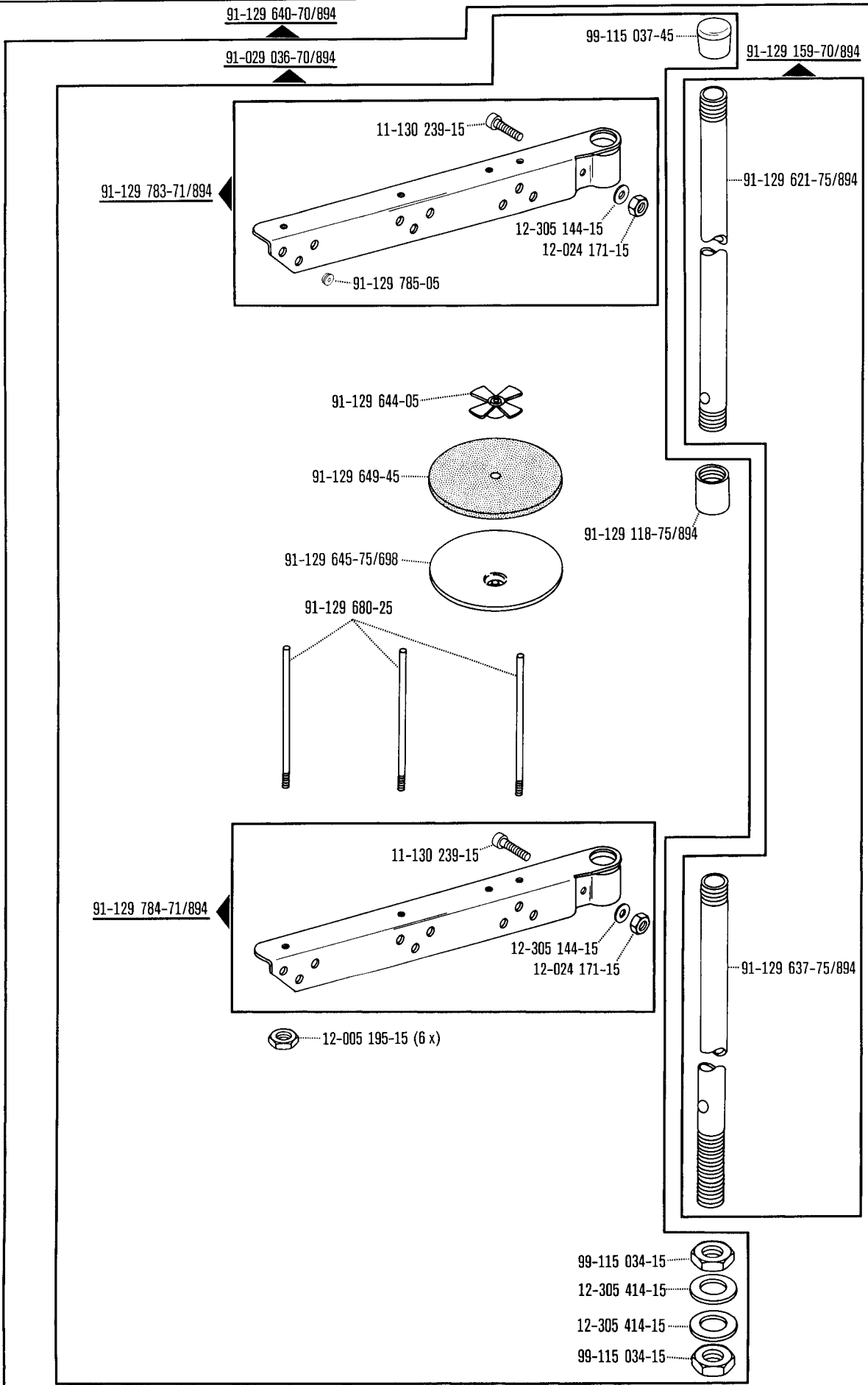

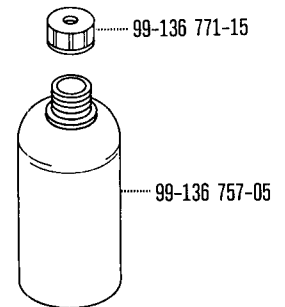
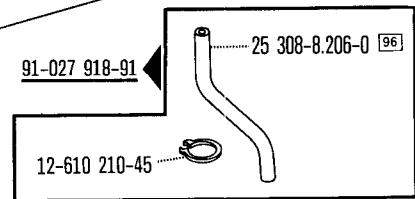
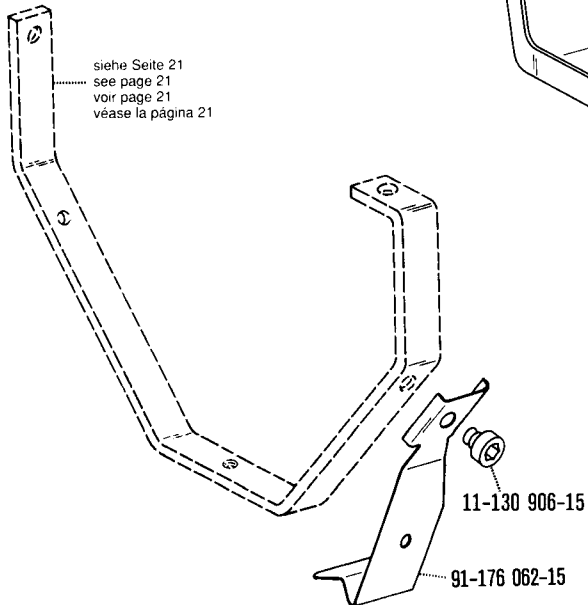
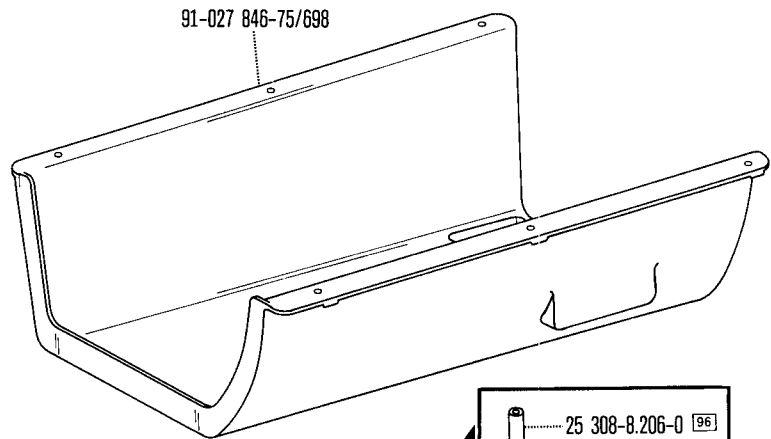
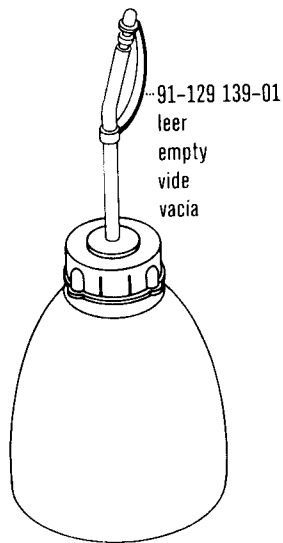
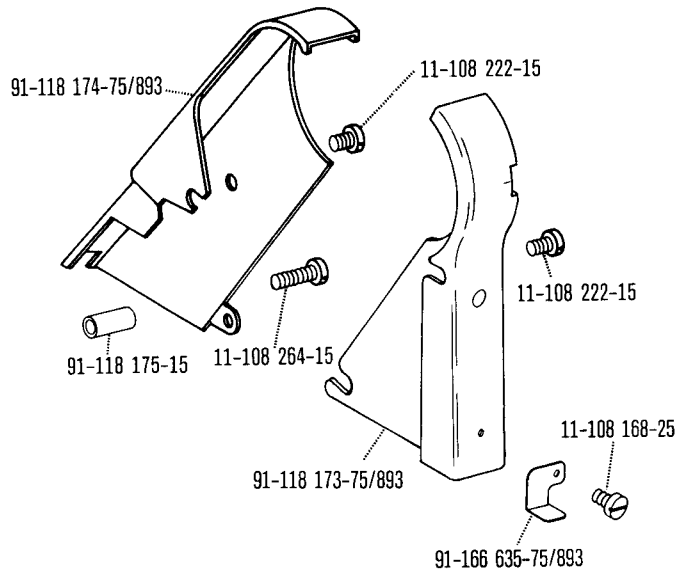
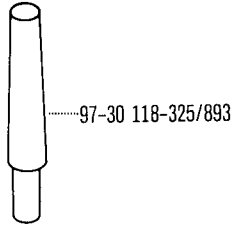

91-056 578-91

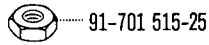
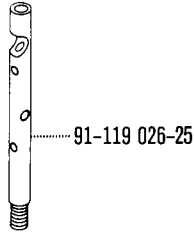
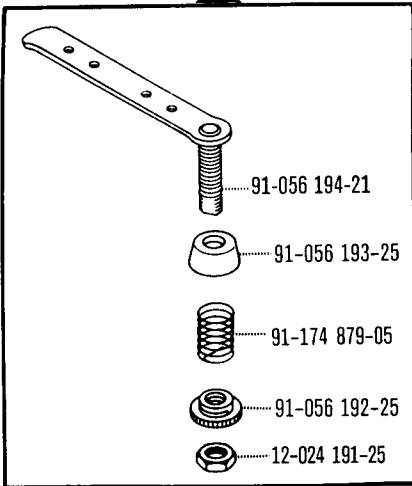

91-038 800-71/699

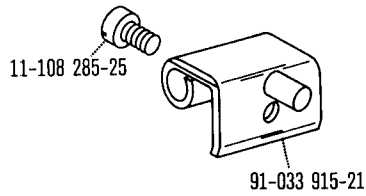
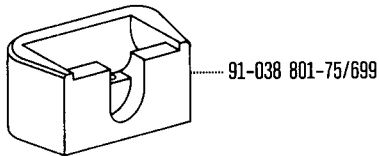
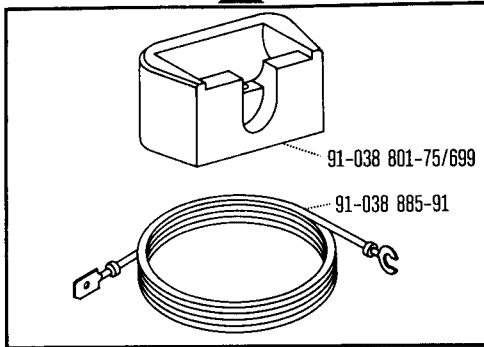

91-027 651-75/699

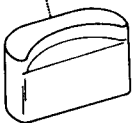

91-029 692-75/792



91-171 412-71/893

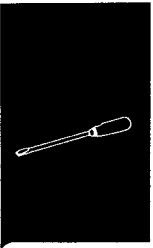
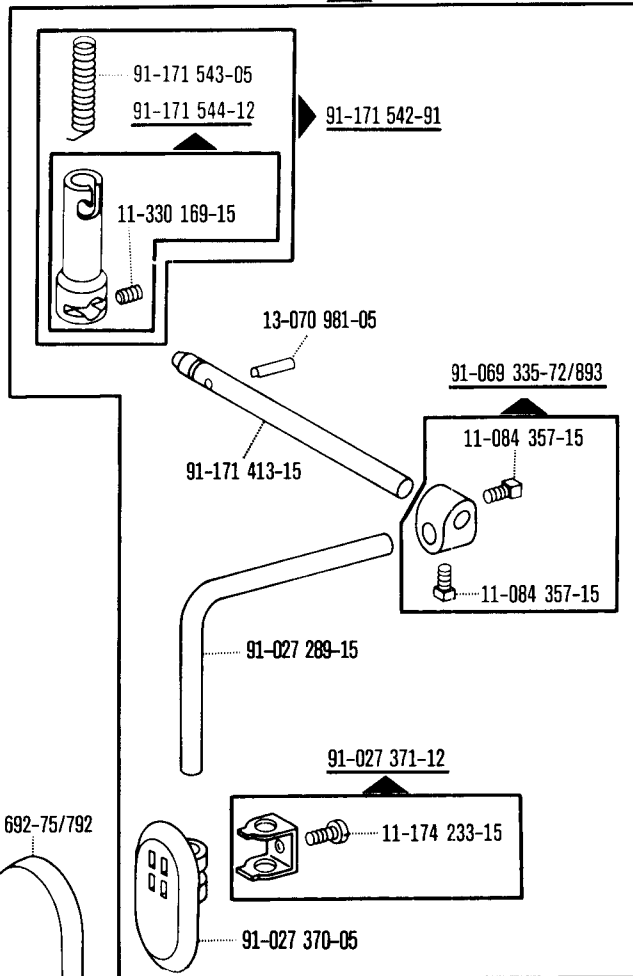

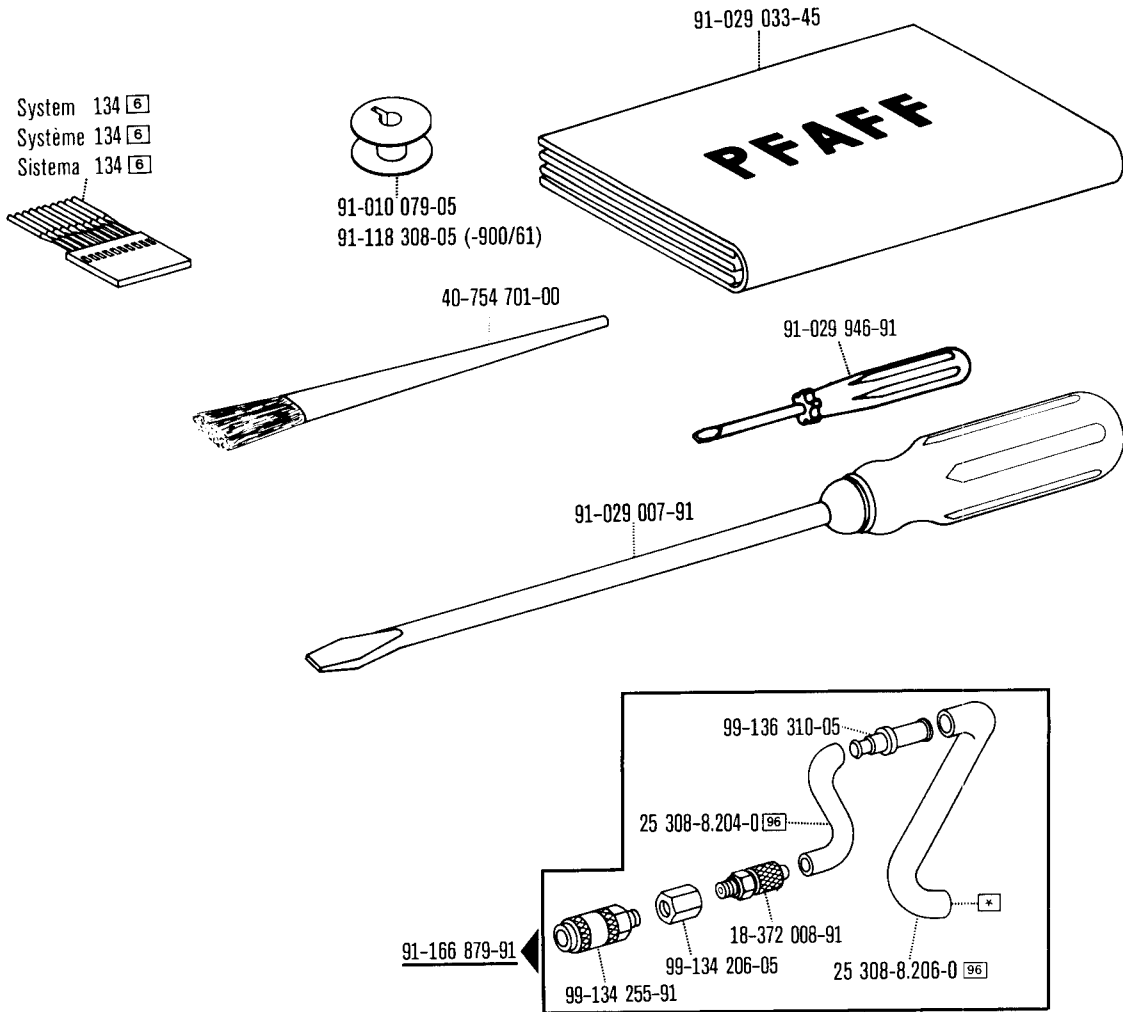

Einstellehren  
 Adjustment gauges  
 Calibres  
 Calibres de ajuste

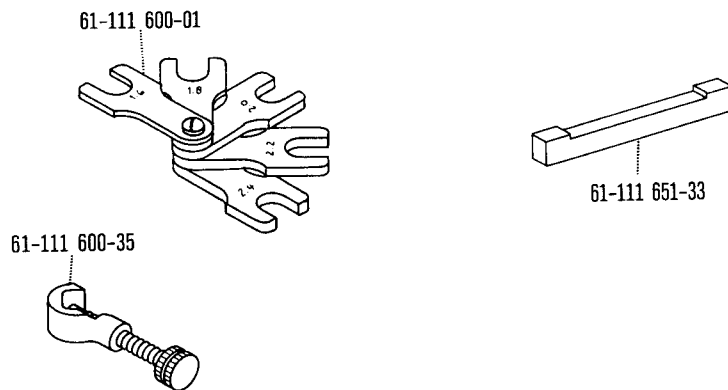



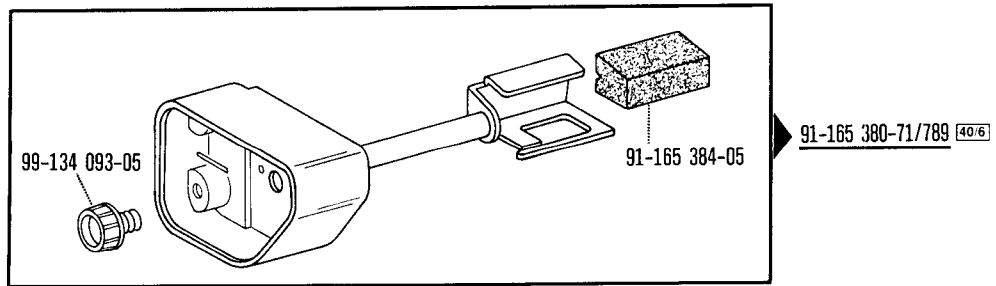
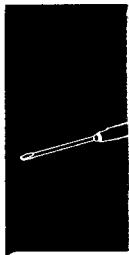
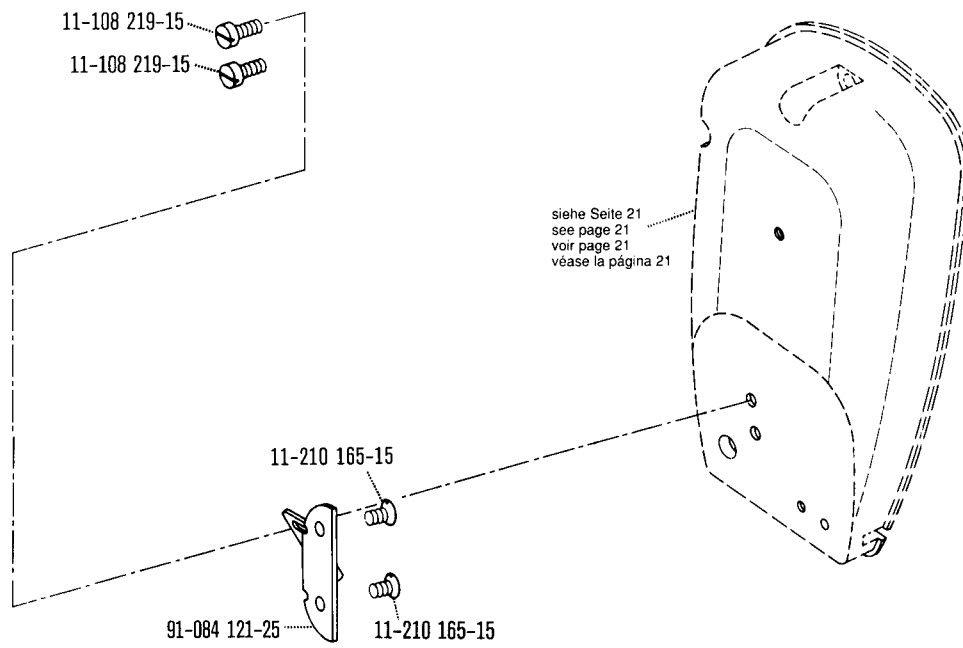

**Keilriemenscheiben-Tabelle**

**Table of V-belt pulleys**

**Tableau des poulies à gorge en V**

**Tabla de poleas para correas en "V" PFAFF 441-R-705/03; -755/03**

Nähgeschwindigkeit max., Stiche/min Maximum sewing speed in s.p.m. Nombre de points max./mn Número máx. de puntadas por minuto	Motordrehzahl U/min Motor speed in r.p.m. Régime moteur en tours/mn Régimen del motor en r.p.m.	Frequenz Frequency Fréquence Frecuencia	Handrad-Durchmesser <sup>1)</sup> in mm Balance wheel diameter <sup>1)</sup> in mm Diamètre du volant <sup>1)</sup> en mm Diámetro del volante <sup>1)</sup> en mm	Keilriemenscheiben-Durchmesser <sup>1)</sup> in mm V-belt pulley diameter <sup>1)</sup> in mm Diamètre de la poulie à gorge <sup>1)</sup> en mm Diámetro de la polea para correa en "V" <sup>1)</sup> en mm	Teilenummer der Keilriemenscheibe Part number of V-belt pulley Numéro de pièce des poulies à gorge en V Nº de las piezas de poleas para correas en "V"
2500	1700	60 Hz	65	95	16-437 080-55
2500	1400	50 Hz	65	118	16-437 120-55
2000	1700	60 Hz	65	75	16-437 040-55
2000	1400	50 Hz	65	95	16-437 080-55
1700	1700	60 Hz	65	67	16-437 020-55
1700	1400	50 Hz	65	80	16-437 050-55



<sup>1)</sup> Wirksamer Durchmesser  
Effective diameter  
Diamètre effectif  
Diámetro efectivo

Öl Oil Huile Aceite	Mittelpunkts- Viskosität bei: Mean viscosity at: Viscosité moyenne à: Viscosidad media a:		Dichte bei: Density of: Densité à: Densidad a:		Bestellnummer für Behälter mit: Part number for can with: Numéro de commande pour récipients avec: Número de pedido para recipientes con:		
	°C	mm <sup>2</sup> /s	°C	g/cm <sup>3</sup> (g/ml)	1 Liter 1 Litre 1 Litros	5 Liter 5 Litre 5 Litros	10 Liter 10 Litre 10 Litros
280-1-120 144	40	22,0	15	0,865	91-129 917-91	91-129 919-91	91-129 920-91
280-1-120 217			21	0,810	91-129 941-91		

Fett Grease Graisse Grasa	Penetration Penetration Pénétración Penetración	Tropfpunkt Drip-point Point de suintement Punto de goteo	Bestellnummer für Behälter mit: Part number for can with: Numéro de commande pour récipients avec: Número de pedido para recipientes con:	
			mm/10	°C
280-1-120 243	375-405	150	280-1-120 243	
280-1-120 247	220-250	185		280-1-120 247
280-1-120 205				280-1-120 205

**PFAFF 441-R-705/03; -755/03**

No.	Seite Page Pages Página	No.	Seite Page Pages Página	No.	Seite Page Pages Página	No.	Seite Page Pages Página
11-039 225-15	11	11-130 293-15	19, 26, 27	11-210 938-15	17	12-305 084-15	28
11-039 306-15	17, 24	11-130 305-15	31	11-225 184-15	23	12-305 114-15	20
11-084 357-15	29, 35	11-130 906-15	34	11-225 223-15	23	12-305 144-15	33
11-108 093-15	8, 26	11-132 169-15	11	11-225 312-15	29	12-305 174-15	15, 20
11-108 168-25	34	11-132 172-15	25, 27	11-250 084-25	13	12-305 414-15	33
11-108 171-15	17, 19, 24, 29	11-132 223-15	23, 24, 25	11-305 314-15	14	12-315 080-15	23
11-108 171-25	16	11-133 538-15	21	11-314 166-15	25, 27	12-315 110-15	29
11-108 174-15	19, 20	11-135 223-15	17	11-314 277-15	15	12-335 151-15	10, 19
11-108 204-15	20	11-135 286-15	26	11-314 280-15	10, 23	12-360 054-05	23
11-108 219-15	37	11-135 292-15	10	11-314 946-15	11, 16	12-360 103-05	26
11-108 222-15	34	11-170 278-15	14	11-314 964-15	27	12-500 190-45	31
11-108 234-15	14, 20, 21	11-173 174-15	9	11-315 917-05	14	12-518 210-45	9
11-108 237-15	21	11-173 222-15	29	11-317 167-15	11	12-610 170-45	16, 17, 24, 25
11-108 246-15	21	11-173 664-15	8	11-317 176-15	20	12-610 200-45	16, 24
11-108 255-15	27	11-174 173-15	8, 15	11-317 950-15	17, 24	12-610 210-45	11, 34
11-108 264-15	34	11-174 176-15	11	11-330 166-15	11	12-610 250-45	14, 26
11-108 285-15	21	11-174 233-15	29, 35	11-330 169-15	29, 35	12-610 280-45	15
11-108 285-25	35	11-174 915-15	26	11-330 217-15	25	12-610 370-45	12
11-108 294-15	9	11-178 172-15	9, 10	11-330 220-15	11	12-610 380-45	20
11-130 089-15	10	11-210 043-15	9	11-330 952-15	10	12-618 150-45	20
11-130 092-15	23	11-210 044-15	17, 25	11-330 964-15	8, 12, 13, 17, 18, 24	12-624 210-45	23
11-130 097-15	28	11-210 078-15	16, 24	11-335 902-15	13, 14, 18	12-640 130-55	13
11-130 101-15	28	11-210 081-15	27	11-341 901-15	12, 15, 18, 20	12-640 150-55	20
11-130 170-15	8, 28	11-210 087-15	20	11-341 902-15	13, 14, 17, 25	12-640 170-55	14
11-130 173-15	10, 20	11-210 165-15	37	11-341 905-15	13, 16, 17, 24, 25	12-640 190-55	23
11-130 176-15	9, 15, 27	11-210 165-25	13	11-343 901-15	10	12-640 200-55	15, 23
11-130 179-15	9, 28	11-210 168-15	17	12-005 154-15	20	12-640 210-55	9, 15
11-130 224-15	9, 12, 13, 15, 16, 21	11-210 168-25	13	12-005 195-15	33	12-640 220-55	10
11-130 227-15	12	11-210 174-15	17, 24	12-024 121-15	28	12-664 290-45	9
11-130 233-15	23	11-210 186-15	18	12-024 151-15	10	12-664 350-45	15
11-130 239-15	29, 33	11-210 210-15	11, 24	12-024 171-15	27, 29, 33	12-664 390-45	15
11-130 284-15	27	11-210 216-15	21	12-024 191-15	14, 15	13-030 272-05	20
11-130 287-15	12, 15, 27	11-210 288-15	14	12-024 191-25	35	13-030 310-05	14

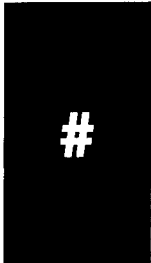

**PFAFF 441-R-705/03; -755/03**

No.	Seite Page Pages Página	No.	Seite Page Pages Página	No.	Seite Page Pages Página	No.	Seite Page Pages Página
13-033 004-05	17, 24	14-756 901-01	9	91-010 157-01	16	91-038 885-91	35
13-033 097-05	11	15-032 006-45	29	91-010 158-05	16	91-053 938-91	10
13-033 148-05	9	15-120 709-05	25	91-010 159-91	16	91-055 872-93	9
13-033 469-05	14	15-120 916-05	16	91-010 166-05	16, 25	91-055 874-93	9
13-033 493-05	15	16-437 020-55	39	91-010 178-05	16, 25	91-056 192-25	35
13-052 142-15	23	16-437 040-55	39	91-010 185-05	11	91-056 193-25	35
13-060 316-05	27	16-437 050-55	39	91-010 937-05	11	91-056 194-21	35
13-060 400-05	21	16-437 080-55	39	91-011 391-45	21	91-056 578-91	35
13-064 259-05	26	16-437 120-55	39	91-017 378-15	15	91-066 381-15	8
13-070 981-05	29, 35	18-372 008-91	36	91-018 152-05	27	91-069 037-15	20
14-012 555-01	15	40-754 701-00	36	91-018 293-05	16, 25	91-069 079-72/895	10
14-012 562-01	16, 24	61-111 600-01	36	91-019 891-05	25	91-069 160-04	13
14-016 080-01	15	61-111 600-35	36	91-020 086-15	17, 24	91-069 292-05	21
14-016 126-01	16, 24	61-111 651-33	36	91-020 490-15	14, 29	91-069 335-72/893	29, 35
14-016 151-91	13, 17, 25	71-17 00-0131	28	91-021 123-05	29	91-069 468-15	12
14-016 153-01	13, 17, 25	71-21 00-0174	28	91-023 505-25	8	91-084 121-25	37
14-016 171-91	26	71-37 00-0132	19, 28, 29	91-025 874-05	10	91-090 751-05	28
14-016 173-01	26	71-37 00-0133	26, 28	91-027 289-15	29, 35	91-090 823-91	28
14-018 613-01	17, 18, 24	91-000 390-05	25	91-027 370-05	29, 35	91-094 905-91	29
14-018 614-91	17, 18, 24	91-000 390-15	16	91-027 371-12	29, 35	91-095 850-91	28
14-018 643-01	13	91-000 529-15	16, 25	91-027 651-75/699	35	91-100 281-25	13
14-018 644-91	13	91-000 928-15	16, 25	91-027 846-75/698	34	91-100 296-25	15
14-215 013-13	11, 12	91-002 065-05	11	91-027 918-91	34	91-100 331-15	10
14-215 022-13	16, 17, 24, 25	91-002 262-25	11	91-028 469-05	15	91-100 355-05	8
14-215 028-13	12, 15, 20	91-004 005-05	8, 11	91-029 007-91	36	91-100 396-15	16, 25
14-215 118-13	15	91-004 006-05	8, 11	91-029 033-45	36	91-101 921-15	20
14-215 124-13	8, 12, 15	91-004 188-05	11	91-029 036-70/894	33	91-105 447-15	11
14-215 253-13	12	91-006 584-05	11	91-029 412-71/893	35	91-106 205-15	11
14-218 080-01	11	91-006 617-05	17, 25	91-029 692-75/792	29, 35	91-113 191-01	25
14-602 901-01	13	91-010 023-05	11	91-029 946-91	36	91-113 192-91	25
14-680 030-15	17, 18, 24	91-010 079-05	16, 36	91-033 915-21	35	91-113 193-05	25
14-680 060-15	13, 17, 25	91-010 115-05	8	91-038 800-71/699	35	91-118 022-05	26
14-680 070-15	13, 26	91-010 116-05	8, 11	91-038 801-75/699	35	91-118 047-91	16

**PFAFF 441-R-705/03; -755/03**

No.	Seite Page Pages Página	No.	Seite Page Pages Página	No.	Seite Page Pages Página	No.	Seite Page Pages Página
91-118 048-91	17, 25	91-118 175-15	34	91-118 763-92	16	91-119 049-05	11
91-118 098-25	13	91-118 196-12	8	91-118 764-01	17, 25	91-119 056-05	20
91-118 099-91	13	91-118 200-91	17, 25	91-118 765-05	17, 25	91-119 057-05	20
91-118 100-71/895	21	91-118 201-15	17, 25	91-118 766-05	17, 25	91-119 059-05	20
91-118 101-71/895	21	91-118 275-93	13	91-118 782-72/851	17	91-119 081-91	18
91-118 102-71/895	21	91-118 308-05	25, 36	91-118 787-15	16, 24	91-119 084-05	15
91-118 119-72/895	21	91-118 426-05	16	91-118 788-75/851	17	91-119 085-05	9, 15
91-118 120-91	12	91-118 430-25	11	91-118 790-07	17, 24	91-119 087-05	9, 15
91-118 121-92	12	91-118 434-91	16, 24	91-118 791-05	16	91-119 093-21	11
91-118 122-15	12	91-118 504-92	8, 12	91-118 796-05	16, 24	91-119 098-75/893	21
91-118 123-05	12	91-118 509-05	21	91-118 835-24	16	91-119 112-01	15
91-118 124-92	12	91-118 518-05	11	91-118 844-24	16	91-119 115-01	15
91-118 138-93	18	91-118 535-05	10	91-118 857-05	14	91-119 116-91	15
91-118 140-92	20	91-118 553-05	11	91-118 875-91	16	91-119 121-12	17, 24
91-118 144-05	23	91-118 570-92	13	91-118 877-91	16	91-119 150-91	9
91-118 148-05	14	91-118 594-15	8	91-118 893-92	12, 15	91-119 158-15	9
91-118 149-91	17, 25	91-118 600-91	8, 12, 15	91-118 931-05	13	91-119 159-05	9, 15
91-118 150-72/851	21	91-118 612-05	12, 20	91-118 934-91	13	91-119 162-11	9, 15
91-118 150-75/851	21	91-118 681-05	13	91-118 935-05	13	91-119 163-12	9, 15
91-118 151-05	21	91-118 682-05	13	91-118 937-01	13	91-119 164-12	9, 15
91-118 152-05	21	91-118 683-05	13	91-118 939-21	13	91-119 165-15	10
91-118 154-90	16, 24	91-118 685-05	13	91-118 940-05	13	91-119 347-05	11
91-118 155-91	17, 24	91-118 703-11	17, 24	91-118 943-71/698	11	91-119 377-05	16
91-118 156-11	17, 24	91-118 704-15	17, 24	91-119 004-05	21	91-119 469-05	9
91-118 162-11	15	91-118 707-12	17, 24	91-119 013-92	11	91-119 478-93	9
91-118 165-71/951	15	91-118 711-05	16, 17, 24, 25	91-119 018-01	10	91-119 491-05	9
91-118 166-75/951	15	91-118 717-72/895	16	91-119 018-02	10	91-119 502-91	9
91-118 167-05	15	91-118 724-91	18	91-119 019-05	10	91-119 503-05	9
91-118 168-05	15	91-118 726-12	18	91-119 021-21	11	91-119 506-01	9
91-118 169-05	15	91-118 759-92	17, 25	91-119 023-15	11	91-119 507-91	9
91-118 170-05	15	91-118 760-91	16	91-119 024-15	11	91-119 509-11	12
91-118 173-75/893	34	91-118 761-15	16	91-119 026-25	35	91-119 544-05	15
91-118 174-75/893	34	91-118 762-05	16, 24	91-119 027-25	11	91-119 546-05	15

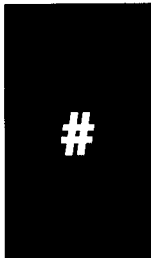

**PFAFF 441-R-705/03; -755/03**

No.	Seite Page Pages Página	No.	Seite Page Pages Página	No.	Seite Page Pages Página	No.	Seite Page Pages Página
91-119 681-93	9	91-129 917-91	40	91-166 278-91	29	91-171 542-91	35
91-119 687-75/893	21	91-129 919-91	40	91-166 279-11	29	91-171 543-05	29, 35
91-119 704-91	13	91-129 920-91	40	91-166 279-70/893	29	91-171 544-12	29, 35
91-119 705-12	13	91-129 941-91	40	91-166 281-15	29	91-172 910-05	29
91-119 763-05	11	91-130 035-07	27	91-166 282-15	29	91-173 029-05	8
91-119 765-05	11	91-131 019-15	26	91-166 283-11	29	91-173 133-15	29
91-119 766-71/698	11	91-133 109-05	18	91-166 322-05	15	91-173 134-92	29
91-119 787-93	9	91-140 199-02	16, 25	91-166 323-05	18	91-173 240-91	25
91-119 798-93	9	91-140 239-05	17, 24	91-166 324-05	18	91-173 296-92	10
91-119 802-91	9	91-140 242-05	19	91-166 329-91	15	91-173 297-01	10
91-119 803-91	9	91-140 456-05	25	91-166 339-91	29	91-173 297-92	10
91-119 807-15	9	91-140 551-91	25	91-166 396-11	23	91-173 311-91	29
91-119 886-05	9, 15	91-140 676-05	24	91-166 493-05	11	91-173 501-71/951	27
91-119 940-01	8	91-140 945-05	16, 25	91-166 631-91	18	91-173 502-75/951	27
91-119 942-93	9	91-141 543-05	17, 24	91-166 632-15	18	91-173 504-92	27
91-119 953-15	9	91-164 527-71/893	29	91-166 633-12	18	91-173 505-05	20, 27
91-119 954-15	9	91-164 615-05	11	91-166 635-75/893	34	91-173 506-05	27
91-119 956-15	9	91-164 685-25	11	91-166 717-15	21	91-173 507-05	27
91-119 961-05	9, 15	91-165 356-71/893	20	91-166 718-15	29	91-173 509-15	28
91-119 962-05	9, 15	91-165 357-15	20	91-166 824-05	8	91-173 516-05	27
91-129 118-75/894	33	91-165 358-11	20	91-166 879-91	36	91-173 517-92	27
91-129 139-01	34	91-165 361-71/893	20	91-166 893-91	14	91-173 524-75/951	27
91-129 159-70/894	33	91-165 364-05	20	91-166 894-15	14	91-173 541-15	23
91-129 621-75/894	33	91-165 365-05	20	91-167 636-05	27	91-173 545-91	26
91-129 637-75/894	33	91-165 375-91	8	91-168 046-15	11	91-173 546-05	26
91-129 640-70/894	33	91-165 377-25	8	91-168 047-14	11	91-173 553-05	23
91-129 644-05	33	91-165 380-71/789	37	91-168 061-75/893	11	91-173 556-72/951	26
91-129 645-75/698	33	91-165 384-05	37	91-168 194-71/698	11	91-173 559-72/951	26
91-129 649-45	33	91-165 440-91	11	91-168 480-15	14	91-173 562-05	26
91-129 680-25	33	91-165 441-01	11	91-170 913-72/893	14	91-173 572-05	16, 24
91-129 783-71/894	33	91-165 443-04	11	91-171 042-45	13	91-173 594-15	27
91-129 784-71/894	33	91-165 444-91	13	91-171 049-05	13	91-173 595-15	28
91-129 785-05	33	91-165 445-91	13	91-171 413-15	29, 35	91-173 596-75/895	21

**PFAFF 441-R-705/03; -755/03**

No.	Seite Page Pages Página	No.	Seite Page Pages Página	No.	Seite Page Pages Página	No.	Seite Page Pages Página
91-173 657-05	18, 25	91-173 915-92	24	91-176 089-05	27	91-266 316-91	23
91-173 674-15	27	91-173 924-11	25	91-176 090-05	27	91-266 336-01	8
91-173 676-15	10	91-173 925-91	12	91-176 091-05	27	91-266 340-05	19
91-173 840-92	14	91-173 927-15	25	91-176 092-02	27	91-700 249-15	23
91-173 841-01	14	91-173 929-05	25	91-176 093-05	25	91-700 324-05	10
91-173 842-05	14	91-173 931-91	24	91-176 095-91	27	91-700 366-15	11
91-173 843-02	14	91-173 972-05	16, 17, 24, 25	91-176 096-15	27	91-700 388-15	8, 14
91-173 844-91	10	91-173 973-15	16, 17, 24, 25	91-176 138-15	14	91-700 412-25	11, 21
91-173 845-11	10	91-173 988-05	18	91-176 242-15	29	91-700 510-15	10, 13
91-173 849-05	10	91-174 155-12	25	91-176 288-05	25	91-700 689-15	18, 20
91-173 850-05	10	91-174 783-05	13	91-176 289-05	25	91-700 785-15	10, 15
91-173 854-05	10	91-174 879-05	35	91-176 290-05	25	91-701 319-25	8
91-173 856-11	10	91-175 038-91	20	91-176 302-05	11	91-701 515-15	26
91-173 874-11	23	91-175 044-05	20	91-176 315-05	11	91-701 515-25	35
91-173 876-05	23	91-175 045-05	20	91-176 332-25	11	91-701 522-25	11
91-173 877-05	23	91-175 046-05	20	91-176 432-05	27	96-730 002-05	10
91-173 878-05	23	91-175 097-05	8	91-176 435-05	26	97-30 118-325/893	34
91-173 879-05	23	91-175 099-05	8	91-186 659-15	23	99-115 034-15	33
91-173 880-05	23	91-175 108-90	9	91-187 293-75/893	31	99-115 037-45	33
91-173 881-05	23	91-175 109-90	9	91-187 426-70/893	31	99-133 116-01	9
91-173 882-05	23	91-175 110-91	8	91-188 163-15	23	99-133 283-15	8, 12, 15
91-173 883-91	23	91-175 183-91	20	91-266 138-91	17, 24	99-134 093-05	37
91-173 885-15	23	91-175 184-90	20	91-266 139-15	17, 24	99-134 206-05	36
91-173 886-05	10	91-175 187-01	20	91-266 140-15	19	99-134 255-91	36
91-173 888-05	12	91-175 189-01	20	91-266 141-71/951	26	99-135 161-05	19
91-173 889-92	12	91-175 776-93	9	91-266 142-72/951	26	99-135 549-91	29
91-173 890-92	12	91-176 052-15	16	91-266 147-15	19	99-135 835-05	19
91-173 894-91	23	91-176 062-15	34	91-266 204-71/951	25	99-136 310-05	36
91-173 902-91	26	91-176 074-05	10	91-266 280-01	19	99-136 330-91	29
91-173 910-72/951	24	91-176 075-02	24	91-266 288-15	17, 24	99-136 396-91	24
91-173 911-05	24	91-176 076-91	25	91-266 298-15	23	99-136 546-91	31
91-173 912-75/951	24	91-176 077-15	25	91-266 299-91	23	99-136 757-05	34
91-173 914-15	24	91-176 088-91	27	91-266 311-91	8	99-136 771-15	34

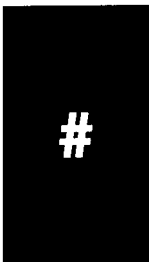



**PFAFF 441-R-705/03; -755/03**

No.	Seite Page Pages Página	No.	Seite Page Pages Página	No.	Seite Page Pages Página	No.	Seite Page Pages Página
280-1-120 144	40						
280-1-120 205	40						
280-1-120 217	40						
280-1-120 243	40						
280-1-120 247	40						
25 161-8.014-9	19						
25 161-8.047-0	8						
25 308-8.204-0	29, 36						
25 308-8.206-0	31, 34, 36						
26 536-3.020-9	19						
26 536-3.030-9	17, 24						

# PFAFF

441-R <sup>-705/03</sup>  
<sup>-755/03</sup>

Unterklassen-Ausstattung

Subclass parts

Composition des sous-classes

Composición de las subclases



**Unterklassen-Übersicht**  
**Table of subclasses**  
**Table des sous-classes**  
**Tabla de subclases**

**PFAFF 441-R-705/03**







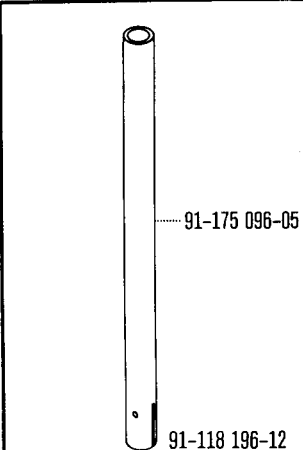
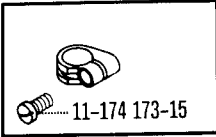
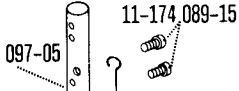

Unterklasse Subclass Sous-classe Subclase	<b>-705/03</b>				
Ausführung Model Version Tipo de máquina	AN 2,5	BN 2,5	A	B	BC
Nadelstange Needle bar Barre à aiguille Barra de aguja	91-175 110-91	91-175 110-91	91-175 110-91	91-175 110-91	91-175 110-91
Stoffschieber <sup>4</sup> Feed dog Griffe Transportador inferior	91-119 544-05	91-119 546-05	91-119 544-05	91-119 546-05	91-119 546-05
Stichplatte <sup>4</sup> Needle plate Plaque à aiguille Placa de aguja	91-058 517-04	91-058 517-04	91-058 518-04	91-058 518-04	91-058 519-04
Nähfuß <sup>4</sup> Presser foot Pied presseur Pie prensateelas	91-055 874-93	91-055 874-93	91-055 874-93	91-055 874-93	91-055 874-93
Fingerschutz Finger guard Protège-doigts Salvadedos	91-053 938-91	91-053 938-91	91-053 938-91	91-053 938-91	91-053 938-91
Unterklasse Subclass Sous-classe Subclase	<b>-705/03-900/61</b>				
Ausführung Model Version Tipo de máquina	AN 2,5	BN 2,5	A	B	BC
Nadelstange Needle bar Barre à aiguille Barra de aguja	91-175 110-91	91-175 110-91	91-175 110-91	91-175 110-91	91-175 110-91
Stoffschieber <sup>4</sup> Feed dog Griffe Transportador inferior	91-119 544-05	91-119 546-05	91-119 544-05	91-119 546-05	91-119 546-05
Stichplatte <sup>4</sup> Needle plate Plaque à aiguille Placa de aguja	91-158 808-04	91-158 808-04	91-158 808-04	91-158 808-04	91-158 809-04
Nähfuß <sup>4</sup> Presser foot Pied presseur Pie prensateelas	91-055 874-93	91-055 874-93	91-055 874-93	91-055 874-93	91-055 874-93
Fingerschutz Finger guard Protège-doigts Salvadedos	91-053 938-91	91-053 938-91	91-053 938-91	91-053 938-91	91-053 938-91

**Unterklassen-Übersicht**  
**Table of subclasses**  
**Table des sous-classes**  
**Tabla de subclases**

**PFAFF 441-R-755/03**

Unterklasse Subclass Sous-classe Subclase	<b>-755/03</b>				
Ausführung Model Version Tipo de máquina	AN 2,5	BN 2,5	A	B	BC
Nadelstange Needle bar Barre à aiguille Barra de aguja	91-175 110-91	91-175 110-91	91-175 110-91	91-175 110-91	91-175 110-91
Stoffschieber <input type="checkbox"/> 4 Feed dog Griffe Transportador inferior	91-119 544-05	91-119 546-05	91-119 544-05	91-119 546-05	91-119 546-05
Stichplatte <input type="checkbox"/> 4 Needle plate Plaque à aiguille Placa de aguja	91-058 517-04	91-058 517-04	91-058 518-04	91-058 518-04	91-058 519-04
Nähfuß <input type="checkbox"/> 4 Presser foot Pied presseur Pie prensatelas	91-119 787-93	91-119 787-93	91-119 787-93	91-119 787-93	91-119 787-93
Fingerschutz Finger guard Protège-doigts Salvadedos	91-053 938-91	91-053 938-91	91-053 938-91	91-053 938-91	91-053 938-91
Unterklasse Subclass Sous-classe Subclase	<b>-755/03-900/61</b>				
Ausführung Model Version Tipo de máquina	AN 2,5	BN 2,5	A	B	BC
Nadelstange Needle bar Barre à aiguille Barra de aguja	91-175 110-91	91-175 110-91	91-175 110-91	91-175 110-91	91-175 110-91
Stoffschieber <input type="checkbox"/> 4 Feed dog Griffe Transportador inferior	91-119 544-05	91-119 546-05	91-119 544-05	91-119 546-05	91-119 546-05
Stichplatte <input type="checkbox"/> 4 Needle plate Plaque à aiguille Placa de aguja	91-158 808-04	91-158 808-04	91-158 808-04	91-158 808-04	91-158 809-04
Nähfuß <input type="checkbox"/> 4 Presser foot Pied presseur Pie prensatelas	91-119 787-93	91-119 787-93	91-119 787-93	91-119 787-93	91-119 787-93
Fingerschutz Finger guard Protège-doigts Salvadedos	91-053 938-91	91-053 938-91	91-053 938-91	91-053 938-91	91-053 938-91

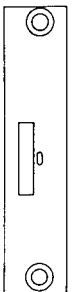
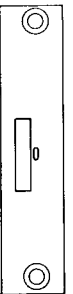
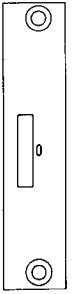
siehe Erläuterungen Register  A-1-1  
see explanations in section  A-1-1  
voir légende registre  A-1-1  
ver explicaciones del registro  A-1-1

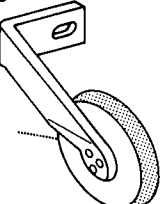
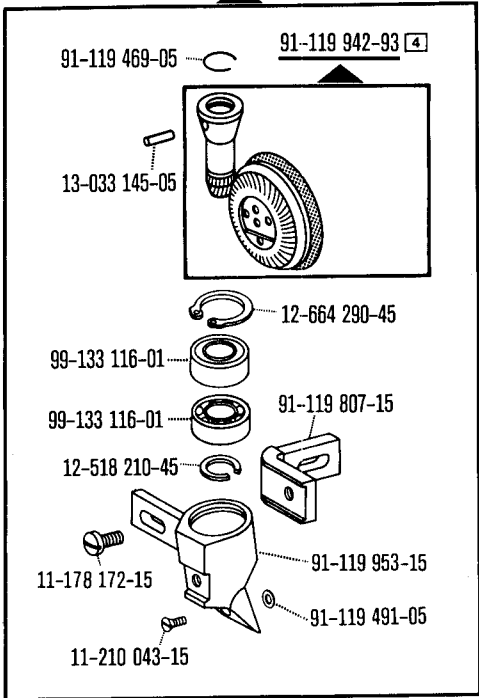
<p>91-175 110-91</p>  <p>91-175 096-05</p> <p>91-118 196-12</p>  <p>11-174 173-15</p>  <p>91-175 097-05</p> <p>11-174 089-15</p>  <p>91-175 098-05</p>	<p>91-119 544-05</p>  <p>-705/03 AN2,5; A          -705/03-900/61 AN2,5; A          -755/03 AN2,5; A          -755/03-900/61 AN2,5; A</p>	<p>91-119 546-05</p>  <p>-705/03 BN2,5; B; B/C          -705/03-900/61 BN2,5; B; B/C          -755/03 BN2,5; B; B/C          -755/03-900/61 BN2,5; B; B/C</p>	<p>91-058 517-04 <span style="border: 1px solid black; padding: 0 2px;">4</span></p>  <p>-705/03 AN2,5; BN2,5          -755/03 AN2,5; BN2,5</p>
<p>91-158 808-04 <span style="border: 1px solid black; padding: 0 2px;">4</span></p>  <p>-705/03-900/61 A; B; AN2,5; BN2,5          -755/03-900/61 A; B; AN2,5; BN2,5</p>	<p>91-158 809-04 <span style="border: 1px solid black; padding: 0 2px;">4</span></p>  <p>-705/03-900/61 B/C          -755/03-900/61 B/C</p>	<p>91-058 518-04 <span style="border: 1px solid black; padding: 0 2px;">4</span></p>  <p>-705/03 A; B          -755/03 A; B</p>	<p>91-058 519-04 <span style="border: 1px solid black; padding: 0 2px;">4</span></p>  <p>-705/03 B/C          -755/03 B/C</p>
<p>91-053 938-91</p>  <p>-705/03          -705/03-900/61          -755/03          -755/03-900/61</p>	<p>11-173 174-15</p>  <p>91-055 874-93 <span style="border: 1px solid black; padding: 0 2px;">4</span></p>  <p>-705/03          -705/03-900/61</p>	<p>91-119 787-93 <span style="border: 1px solid black; padding: 0 2px;">4</span></p>  <p>91-119 469-05</p> <p>13-033 145-05</p> <p>91-119 942-93 <span style="border: 1px solid black; padding: 0 2px;">4</span></p> <p>12-664 290-45</p> <p>99-133 116-01</p> <p>99-133 116-01</p> <p>12-518 210-45</p> <p>91-119 807-15</p> <p>11-178 172-15</p> <p>11-210 043-15</p> <p>91-119 953-15</p> <p>91-119 491-05</p> <p>-755/03          -755/03-900/61</p>	

# PFAFF

**G.M. PFAFF KAISERSLAUTERN  
INDUSTRIEMASCHINEN AG**

Postfach 3020  
D-67653 Kaiserslautern

Königstr. 154  
D-67655 Kaiserslautern

Telefon: (0631) 200-0  
Telefax: (0631) 17202  
E-Mail: [info@pfaff-industrial.com](mailto:info@pfaff-industrial.com)

Gedruckt in der BRD  
Printed in Germany  
Imprimé en R.F.A.  
Impreso en la R.F.A.