

Cylinder-Bed,1-Needle,Unison-Feed Lockstitch
Machine with an Automatic Thread Trimmer

筒型一本針本縫総合送り自動糸切りミシン

DSC-244

DSC-244-4,-6,-7

PARTS LIST

HOW TO MAKE USE OF THIS PARTS LIST

1. As to "#01" and "#02" refer to the "Note" given at the bottom of the respective pages.
2. Codes on the "Qty" column
 - Each numeral indicates the number of parts required.
 - "0.1" and "2.5" indicate the length (in meters) of the respective parts.
3. Parentheses mean that the corresponding part is a subpart that constructs an assembly part.
4. Dotted lines on the Figures indicate assembly parts.

パーツリストご利用に際して

1. リストページの#01、#02等の印は、ページ下の"注記"の説明をご参照下さい。
2. 数量欄の数字は、個数を表し、0.1、2.5等の数値は、長さ(単位メートル)を表します。
3. 数量欄の()は、組部品を構成している子部品であることを意味します。
4. イラストページの-----枠は、組構成であることを意味します。

CONTENTS

目次

1. FRAME & MISCELLANEOUS COVER COMPONENTS	1
頭部・外装関係	
2. MAIN SHAFT & ARM SHAFT COMPONENTS	3
上軸・立軸関係	
3. NEEDLE BAR, THREAD TAKE-UP LEVER & PRESSER BAR COMPONENTS	5
針棒・天秤・押え棒関係	
4. FEED MECHANISM COMPONENTS	7
送り関係	
5. REVERSE FEED MECHANISM COMPONENTS	9
逆送り関係	
6. UPPER FEED MECHANISM & HOOK DRIVING SHAFT COMPONENTS	11
上送り・下軸関係	
7. THREAD TRIMMER COMPONENTS	13
糸切り関係	
8. THREAD TENSION COMPONENTS	15
糸調子関係	
9. LUBRICATION COMPONENTS	17
給油関係	
10. KNEE LIFTER COMPONENTS	18
膝上げ関係	
11. BELT COVER & THREAD WINDER COMPONENTS	19
ベルトカバー・糸巻き関係	
12. THREAD STAND COMPONENTS(For DSC-244)	20
糸立て関係 (DSC-244用)	
13. THREAD STAND COMPONENTS(For DSC-244-4,-6,-7)	21
糸立て関係 (DSC-244-4, -6, -7用)	
14. TABLE COMPONENTS	22
脚卓関係	
15. ACCESSORIES PARTS COMPONENTS	23
付属品関係	
16. GAUGE COMPONENTS	25
ゲージ関係	
17. OPTION COMPONENTS(For DSC-244)	26
オプション関係 (DSC-244用)	
NUMERICAL INDEX OF PARTS	27
索引	

1. FRAME & MISCELLANEOUS COVER COMPONENTS

頭部・外装関係

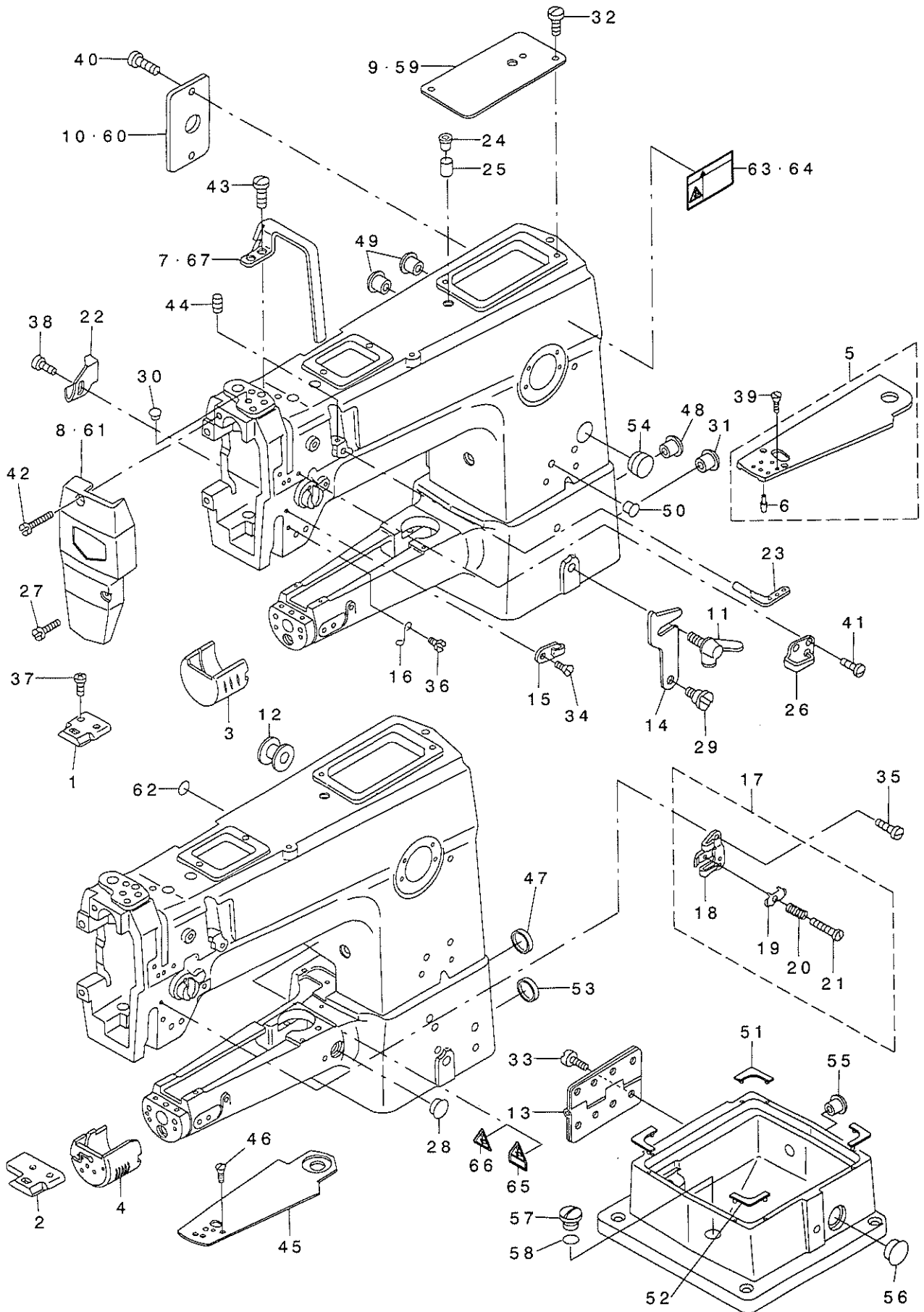

REF. NO	NOTE	PART NO.	DESCRIPTION	品名	Qty
1	#01	B1105-245-000	THROAT PLATE	ハリイタ	1
2	#02	D1105-245-E00	THROAT PLATE	ハリイタ	1
3	#01	B1171-245-000	HOOK COVER	カマカハ -	1
4	#02	D1171-245-E00	HOOK COVER	カマカハ -	1
5	#01	B1173-245-0A0	TOP COVER ASM.	ハットシヨウメンカハ -(クミ)	1
6	#01	B1174-245-000	SET PIN	ハットシヨウメンカハ -トメピン	(1)
7		D1158-241-E00	THREAD TAKE-UP LEVER COVER	デンビシカハ -	1
8		B1121-245-0A0	FACE PLATE ASM.	メンイタ,クミ	1
9		D1150-241-E00	TOP COVER	デンイタ	1
10		B1118-241-H00	SIDE PLATE	マトイタ	1
11		B1116-246-000	WING BOLT	カガカネトメチヨウネジ	1
12	#02	D2414-141-E00	LORD BUSHING	ゴムアツク	1
13		B1128-246-000	HINGE	チヨウハン	1
14		B1117-246-000	HOOK	カガカネ	1
15	#01	B1130-051-000	FRAME THREAD GUIDE, MIDDLE	イトアンナイ	1
16	#01	B1131-562-000	FRAME THREAD GUIDE, LOWER	イトアンナイ ヌタ	1
17	#02	B1130-521-0A0	THREAD GUIDE ASM., LOWER	イトアンナイ ヌタ クミ	1
18		B1130-521-000	THREAD GUIDE	イトアンナイ ヌタ	(1)
19		B1131-521-000	THREAD PRESSER PLATE	ハリイタ オサエイタ	(1)
20		B1132-521-000	THREAD PRESSER PLATE SPRING	ハリイタ オサエイタ ハネ	(1)
21		SD-0380551-SL	HINGE SCREW D= 3.80 H= 5.5	タメネジ D=3.8 H=5.5	(1)
22		B1140-051-000	TAKE-UP OIL SPLASHER	デンビシ ユホ -イタ	1
23	#01	B1128-522-000	THREE HOLE THREAD EYELET	ミツメイトカ	1
24		B1156-115-000	RUBBER PLUG	ウツシク アブラダ マリ フタ	1
25		B3517-009-000	OIL FELT REAR	ゴ-ア アブラダ メフェルト	1
26		B1129-563-000	FRAME THREAD GUIDE, UPPER	イトアンナイ ヌタ	1
27		SS-6092120-SP	SCREW 9/64-40 L=21.2	ヒラネジ 9/64-40 L=21.2	1
28	#02	TA-1250406-RO	RUBBER PLUG D=12.5 L=4	トメピン D=12.5 L=4	1
29		SD-0800352-SP	HINGE SCREW D= 8 H= 3.5	タメネジ D=8 H=3.5	1
30		TA-1050504-RO	RUBBER PLUG	トメピン	2
31		TA-2100904-RO	RUBBER PLUG	トメピン	1
32		SS-7110710-SP	SCREW 11/64-40 L=7	マルヒラネジ 11/64-40 L=7	2
33		SM-6081552-TP	SCREW M8 L=15	ロツカクアホルト	8
34	#01	SS-2090710-SP	SCREW 9/64-40 L=7	マルサラネジ 9/64-40 L=7	1
35	#02	SS-2090710-SP	SCREW 9/64-40 L=7	マルサラネジ 9/64-40 L=7	2
36	#01	SS-3090610-SP	SCREW 9/64-40 L=6	マルネジ 9/64-40 L=6	1
37		SS-2110915-SP	SCREW 11/64-40 L=8.5	マルサラネジ 11/64-40 L=8.5	2
38		SS-3090520-SP	SCREW 9/64-40 L=4.5	マルネジ 9/64-40 L=4.5	1
39		SS-2090710-SP	SCREW 9/64-40 L=7	マルサラネジ 9/64-40 L=7	3
40		SS-7110710-SP	SCREW 11/64-40 L=7	マルヒラネジ 11/64-40 L=7	2
41		SS-2090710-SP	SCREW 9/64-40 L=7	マルサラネジ 9/64-40 L=7	2
42		SS-7110710-SP	SCREW 11/64-40 L=7	マルヒラネジ 11/64-40 L=7	2
43		SS-7150940-SP	SCREW 15/64-28 L=9	マルヒラネジ 15/64-28 L=9	1
44	#01	SS-8110510-SP	SCREW 11/64-40 L=5	トメネジ 11/64-40 L=5	1
45	#02	D1173-245-E00	TOP COVER	ウツメンカハ -	1
46	#02	SS-2090710-SP	SCREW 9/64-40 L=7	マルサラネジ 9/64-40 L=7	1
47	#02	B1180-245-000	PLUG	トメピン	1
48		TA-1120804-RO	RUBBER PLUG	トメピン	1
49		TA-0550604-RO	RUBBER PLUG	トメピン	2
50		TA-0750704-RO	RUBBER PLUG	トメピン	1
51		B1183-245-00A	GASKET, A	スパ -サ (A)	3
52		B1183-245-00B	GASKET, B	スパ -サ (B)	1
53	#02	B1180-245-000	PLUG	トメピン	1
54		TA-1550902-RO	PLUG	トメピン D=15.5 L=9	1
55		TA-0750404-RO	PLUG D=7.5 L=3.5	トメピン D=7.5 L=3.5	1
56		TA-2050406-RO	RUBBER PLUG	トメピン	1
57		SS-7680870-SP	SCREW 9/32 L= 8.0	マルヒラネジ 9/32-28 L=8	1
58		RO-0611801-00	RUBBER RING	0ツツク	1
59	#03	D1150-241-E0A	TOP COVER	デンイタ	1
60	#03	B1118-241-H0A	SIDE PLATE	マトイタ	1
61	#03	B1121-245-0AA	FACE PLATE ASM.	メンイタ(クミ)	1
62		100-04109	GROUND MARK	ク ラット マーク	1
63	#04	CM-3002001-01	SAFETY LABEL, 1(SMALL).	アンゼンラベル 1(シヨウ)	1
64	#05	CM-3002001-A1	SAFETY LABEL 3	アンゼンラベル 3(シヨウ)	1
65	#04	CM-3002000-B2	LABEL(25).	ハザミコミチュウイター(25)	1
66	#06	CM-3002000-B2	CAUTION LABEL(25)	エビケガ チョウイター(25)	1
67	#03	D1158-241-E0A	THREAD TAKE-UP LEVER COVER	デンビシカハ -	1

NOTE (注記)

#01...FOR DSC-244 DSC-244用
 #02...FOR DSC-244-4, -6, -7 DSC-244-4, -6, -7用
 #03...FOR URBAN WHITE アーバンホワイト用
 #04...FOR DOMESTIC USE 国内用
 #05...FOR EXPORT 輸出用
 #06...FOR DSC-244-4(URBAN WHITE)(JE), DSC-244-4(アーバンホワイト)(JE),
 -7(JE)用

2. MAIN SHAFT & ARM SHAFT COMPONENTS

上軸・立軸関係

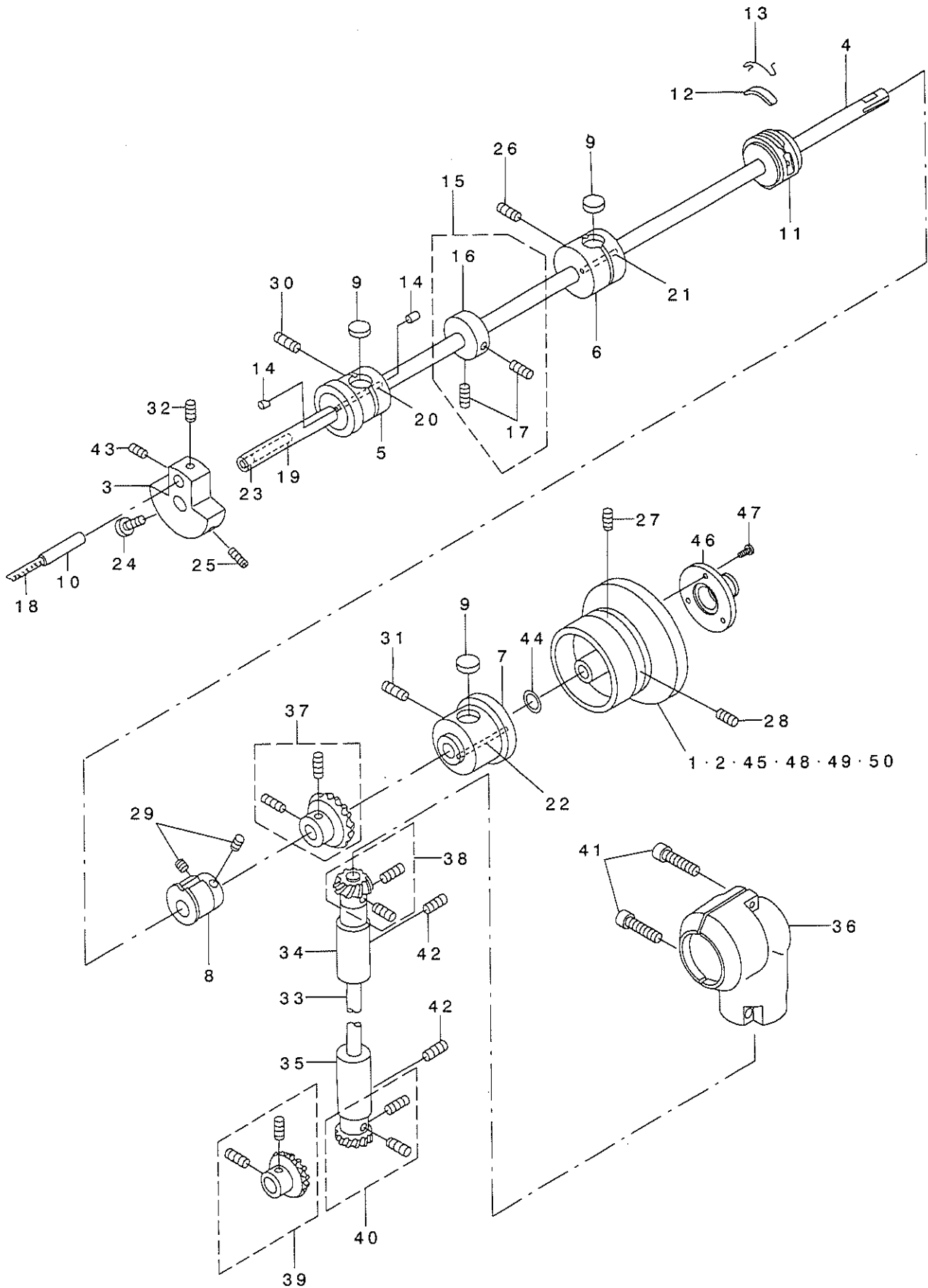

REF. NO	NOTE	PART NO.	DESCRIPTION	品名	Qty
1	#01	B1227-145-00A	HAND WHEEL	ハズミグ ルマ	1
2	#02	D1227-245-EOA	HAND WHEEL	ハズミグ ルマ	1
3		B1206-245-000	COUNTERWEIGHT	ツリアイダレ	1
4		D1201-241-E00	MAIN SHAFT	ウワシク	1
5		B1202-241-H00	MAIN SHAFT BUSHING, FRONT	ウワシク マエメタル	1
6		B1203-241-H00	BUSHING, INTERMEDIATE	ウワシク ナカメタル	1
7		B1204-241-H00	BUSHING, REAR	ウワシク クウシロメタル	1
8		B1211-141-H00	FEED ECCENTRIC CAM	スイハイ オクリ ハンツシ カム	1
9		B1203-051-000	OIL FELT	ウワシク マエメタル フェルト	3
10		B1210-051-000	NEEDLE BAR CRANK PIN	ハリホ - クランクピン	1
11		B1211-226-000	ECCENTRIC RETAINER HOUSING	フタマダサヤ	1
12		B1212-012-000	OIL FELT	フェルト	1
13		B1213-012-000	FELT RETAINER	フェルト オサエ	1
14		TA-0500000-R0	PLUG	トメセン	2
15		CS-127101A-SH	THRUST COLLAR ASM. D=12.7 W=10	スラストウケ D=12.7 W=10 クミ	1
16		CS-1271012-SH	THRUST COLLAR D=12.7 W=10	スラストウケ D=12.7 W=10	(1)
17		SS-8660610-TP	SCREW 1/4-40 L=6	トメネジ 1/4-40 L=6	(2)
18		CQ-5050000-00	OIL WICK	ユツシ	0.1
19		CQ-3030000-00	OIL WICK	ユツシ	0.1
20		CQ-2520000-00	OIL WICK	ユツシ	0.1
21		CQ-2520000-00	OIL WICK	ユツシ	0.1
22		CQ-2520000-00	OIL WICK	ユツシ	0.1
23		TA-0500601-M0	PLUG D=5X5.4 L=6	トメセン D=5X5.4 L=6	1
24		SS-7681750-TP	SCREW 9/32-28 L=16.5	マルヒラネジ 9/32-28 L=16.5	1
25		SS-8681660-TP	SCREW 9/32-28 L=16	トメネジ 9/32-28 L=16	1
26		SS-8151550-SP	SCREW 15/64-28 L=15	トメネジ 15/64-28 L=15	1
27		SS-8151780-SP	SCREW 15/64-28 L=17.0	トメネジ 15/64-28 L=17	1
28		SS-8151550-SP	SCREW 15/64-28 L=15	トメネジ 15/64-28 L=15	1
29		SS-8150710-SP	SCREW 15/64-28 L=7	トメネジ 15/64-28 L=7	2
30		SS-8151550-SP	SCREW 15/64-28 L=15	トメネジ 15/64-28 L=15	1
31		SS-8150710-SP	SCREW 15/64-28 L=7	トメネジ 15/64-28 L=7	1
32		SS-8680540-SP	SCREW 9/32-28 L= 4.5	トメネジ 9/32-28 L=4.5	1
33		B1301-241-H00	UPRIGHT SHAFT	タテシク	1
34		B1302-241-H00	BUSHING, UPPER	タテシク クウワメタル	1
35		B1303-271-000	BUSHING, LOWER	タテシク クシタメタル	1
36		B1305-271-0B0	GEAR CASE ASM.	ウエハク ルマケース (クミ)	1
37		B1305-012-0A0	GEAR ASM.	ウワカサハク ルマ ダイ クミ	1
38		B1306-155-0C0	GEAR & PINION ASM.	カサハク ルマ ショーケ クミ	1
39		B1307-155-0A0	GEAR ASM. LARGE	シタカサハク ルマ ダイ クミ	1
40		B1308-155-0A0	PINION ASM.	シタカサハク ルマ ショウ クミ	1
41		SM-6031202-TP	SCREW M3X0.5 L=12	ロツカクアナボルト	2
42		SS-8151550-SP	SCREW 15/64-28 L=15	トメネジ 15/64-28 L=15	2
43		SS-8680730-SP	SCREW 9/32-28 L=7	トメネジ 9/32-28 L=7	1
44		B1605-201-000	METAL WASHER	メタルサガネ	1
45	#03	213-02203	HAND WHEEL	ハズミグ ルマ	1
46	#03	D1230-552-B00	FLANGE	ハズミグ ルマ フランジ	1
47	#03	SS-7111120-SP	SCREW 11/64-40 L=10.5	マルヒラネジ 11/64-40 L=10.5	3
48	#05	D1227-245-G00	HAND WHEEL	ハズミグ ルマ	1
49	#04	B1227-145-00B	HAND WHEEL	ハズミグ ルマ	1
50	#06	213-08101	HAND WHEEL	ハズミグ ルマ	1

NOTE (注記)

#01	FOR DSC-244	DSC-244用
#02	FOR DSC-244-4, -6	DSC-244-4, -6用
#03	OPTIONAL PARTS FOR DSC-244	DSC-244用オプショナル部品
#04	FOR DSC-244(URBAN WHITE)	DSC-244(アールンホワイト)用
#05	FOR DSC-244-4(URBAN WHITE), -7	DSC-244-4(アールンホワイト), -7用
#06	OPTIONAL PARTS FOR DSC-244(URBAN WHITE)	DSC-244(アールンホワイト)用オプショナル部品

3. NEEDLE BAR, THREAD TAKE-UP LEVER & PRESSER BAR COMPONENTS

針棒・天秤・押え棒関係

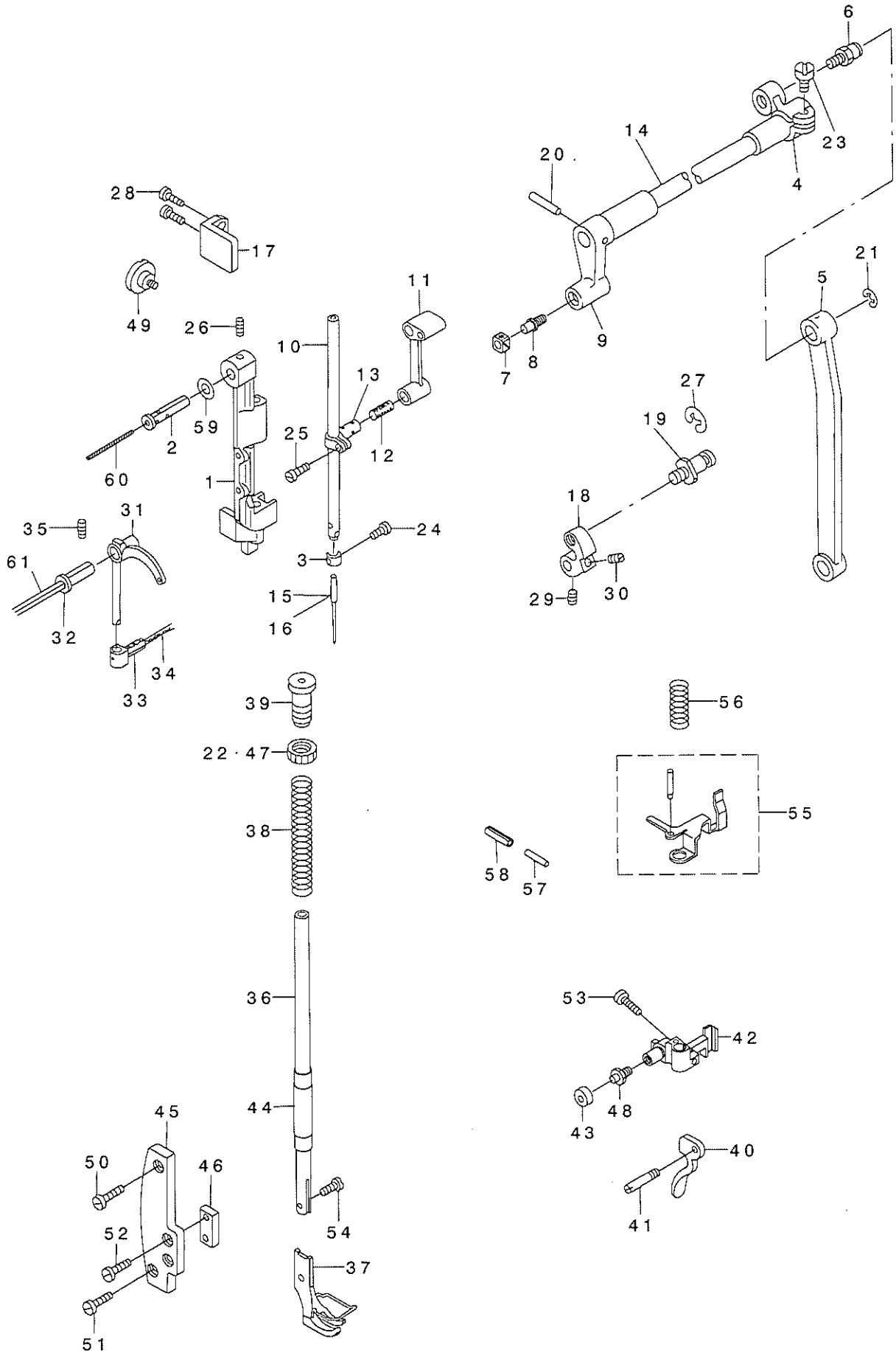

REF. NO	NOTE	PART NO.	DESCRIPTION	ヒョウメイ	Qty
1		B1420-563-000	NEEDLE BAR FRAME	ハリホウ ウヨウトウ ウダ イ	1
2		B1906-051-000	TAKE-UP LEVER PIN	テンビン ササエシク	1
3		B1419-245-000	NEEDLE BAR THREAD GUIDE	ハリホウ ウイトカケ	1
4		B1431-241-H00	ROCK SHAT REAR CRANK	ハリホウ -ヨート- - コ-フ ウデ	1
5		B1434-245-000	DRIVING ROD	ハリホウ ウヨウトウ ウロツト	1
6		B1424-158-000	HINGE SCREW	ハリホウ -ヨート- -オクリウデ ダンネジ	1
7		B1414-232-000	SQUARE BLOCK	カクゴ マ	1
8		B1410-771-000	STUD	ハリホウ - ヨート - カクゴ マジク	1
9		B1428-563-000	ROCK SHAFT FRONT CRANK	ハリホウ ウヨウトウ ウセソフ ウデ	1
10		D1401-245-E00	NEEDLE BAR	ハリホウ ウ	1
11		D1408-241-E00	NEEDLE BAR CRANK ROD	ハリホウ ウ クランクロツト	1
12		D1412-241-E00	FELT	ハリホウ ウダ キ フェルト	1
13		D1411-241-E00	NEEDLE BAR CONNECTION	ハリホウ ウダ キ	1
14		B1429-241-H00	NEEDLE BAR FRAME LOCK SHAFT	ハリホウ -ヨート- -ジク	1
15	#01	MDP-170B1800	NEEDLE DFX17 #18	ハリ DFX17 #18	1
16	#02	MC-3720011-00	NEEDLE 135X17 #110	ハリ SY3355 110	1
17		B1423-245-000	NEEDLE BAR FRAME GUIDE	ヨウトウ ウダ イソナイ	1
18		B1430-245-000	DRIVING ROD CRANK	ハリホウ ウヨウトウ ウオクリウデ	1
19		B1424-158-000	HINGE SCREW	ハリホウ -ヨート- -オクリウデ ダンネジ	1
20		PT-0301600-S0	TAPERED PIN 3.0X16	テ-ハ- ヒン 3X16	1
21		RE-0700000-K0	E-RING 7	エガ タトメワ 7	1
22	#04	110-71701	NUT	オサエ チョウセツ ネジ ナット	1
23		SS-7151210-SP	SCREW 15/64-28 L=12	マルヒラネジ 15/64-28 L=12	1
24		SS-7080510-TP	SCREW 1/8-44 L=4.5	マルヒラネジ 1/8-44 L=4.5	1
25		SS-7090910-SP	SCREW 9/64-40 L= 8.5	マルヒラネジ 9/64-40 L=8.5	1
26		SS-8151150-SP	SCREW 15/64-28 L=10.5	トメネジ 15/64-28 L=10.5	1
27		RE-0700000-K0	E-RING 7	エガ タトメワ 7	1
28		SS-7110910-TP	SCREW 11/64-40 L= 8.5	マルヒラネジ 11/64-40 L=8.5	2
29		SS-8150710-TP	SCREW 15/64-28 L=7	トメネジ 15/64-28 L=7	1
30		SS-8150830-SP	SCREW	トメネジ 15/64-28 L=8	1
31		B1905-245-000	THREAD TAKE-UP LEVER	テンビン	1
32		B1906-051-000	TAKE-UP LEVER PIN	テンビン ササエシク	1
33		D1907-241-E00	TAKE-UP LEVER THRUST PIN	テンビン スライト ジク	1
34		CQ-2020000-00	OIL WICK	ユツシ	0.1
35		SS-8151150-SP	SCREW 15/64-28 L=10.5	トメネジ 15/64-28 L=10.5	1
36		B1501-241-H00	PRESSER BAR	オサエホ-	1
37		B1524-245-0A0	PRESSER FOOT ASM.	オサエアシ クミ	1
38		B1510-141-H00	PRESSER SPRING	オサエチヨ-セツハネ	1
39		B1509-141-H00	PRESSER SPRING REGULATOR	オサエチヨ-セツネジ	1
40		B1512-141-H00	HAND LIFTER	オサエアケ	1
41		B1515-051-000	HAND LIFTER PIN	オサエアケ ジク	1
42		B1460-245-000	PRESSER LIFTING LEVER BASE	オサエアケ テコダ イ	1
43		D1462-241-E00	CONNECTING PIN ROLLER	オサエアケ テコダ イ ジク コロ	1
44		B1502-541-000	PRESSER BAR BUSHING, LOWER	オサエホ- シタメタル	1
45		D1464-241-E0A	GUIDE PLATE BASE	オサエアケ テコダ イト イタト ダ イ	1
46		D1463-241-E00	PRESSER BAR BRACKET GUIDE	オサエアケ テコ ガ イト	1
47		B1511-555-000	NUT	オサエチヨ-セツネジ ナット	1
48		B1461-245-000	GUIDE SHAFT HINGE SCREW	ガ イト ジク ダンネジ	1
49		SD-0800481-SP	HINGE SCREW D= 8 H= 4.9	ダンネジ D=8 H=4.9	1
50		SS-7150740-SP	SCREW 15/64-28 L=7	マルヒラネジ 15/64-28 L=7	1
51		SS-7621040-SP	SCREW 3/16-32 L= 9.5	マルヒラネジ 3/16-32 L=9.5	1
52		SS-7621040-SP	SCREW 3/16-32 L= 9.5	マルヒラネジ 3/16-32 L=9.5	2
53		SS-7111260-SP	SCREW 11/64-40 L=12	マルヒラネジ 11/64-40 L=12	1
54		SS-6090910-SP	SCREW 9/64-40 L=9	ヒラネジ 9/64-40 L=9	1
55		B1460-246-0A0	THREAD RELEASE GUIDE ASM.	イト エルメ ウケイタ (ケツコウ)	1
56		B1462-053-000	THREAD RELEASE SPRING	イトエルメ ウケイタ ハネ	1
57	#03	103-21107	TENSION RELEASE BAR	イトエルメ オサホ-	1
58	#03	PS-0600502-KP	SPRING PIN	スプリング ヒン	1
59		B1208-019-000	WASHER	ハリホウ - クランクロツト サカネ	1
60		CQ-2520000-00	OIL WICK	ユツシ	0.1
61		D3505-241-E00	OIL WICK	テンビン ササエシク ユツシ A	1

NOTE (注記) #01... FOR DSC-244,-4-1B,-4-1,-6-0B,-6-00,-7
#02... FOR DSC-244-4-1B(JE),-4-1(JE),-7(JE)
#03... FOR DSC-244-4,-6,-7
#04... FOR URBAN WHITE
DSC-244,-4-1B,-4-1,-6-0B,-6-00,-7用
DSC-244-4-1B(JE),-4-1(JE),-7(JE)用
DSC-244-4,-6,-7用
ア-ハ-ソホワイト用

4. FEED MECHANISM COMPONENTS

送り関係

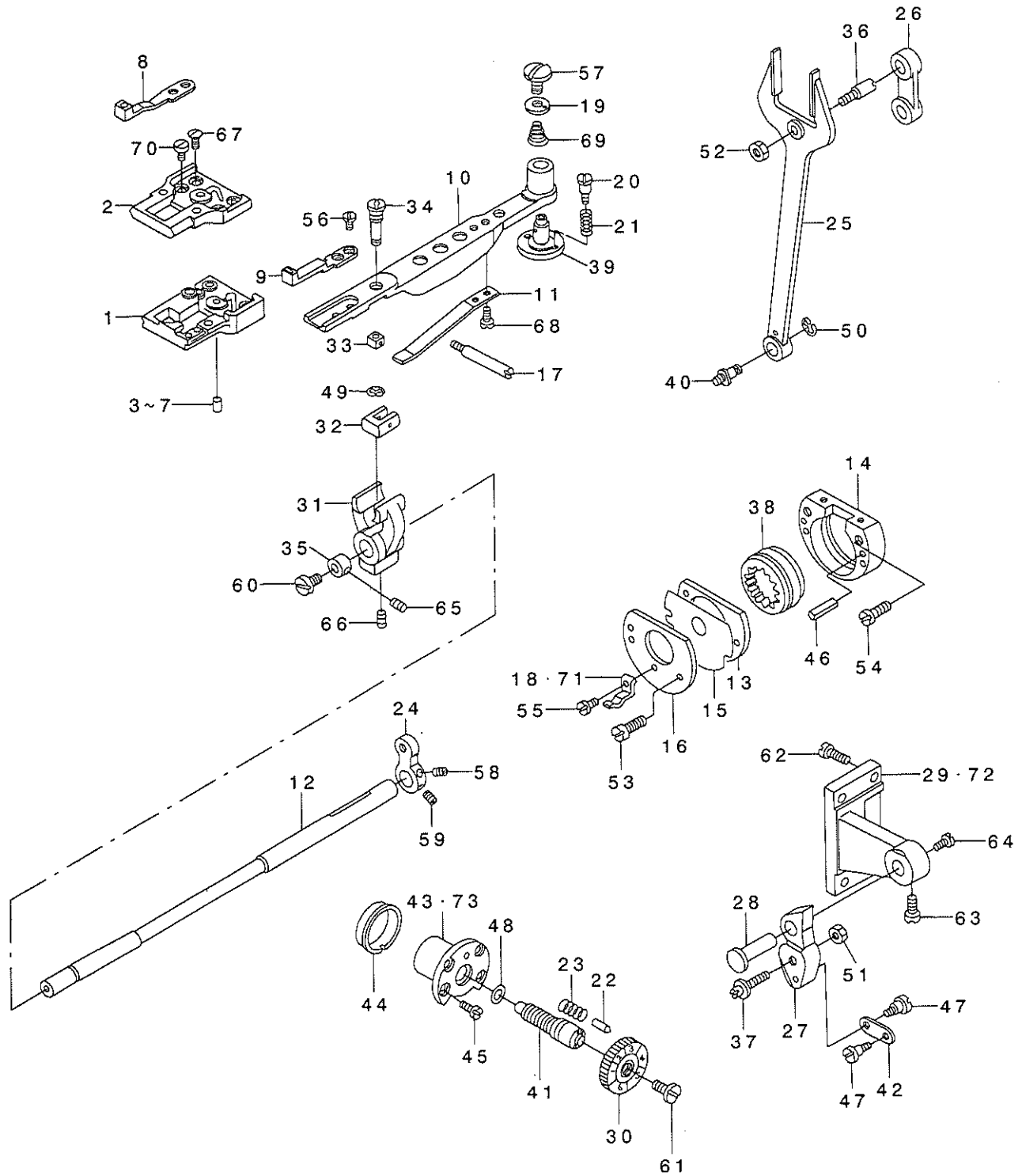

REF. NO	NOTE	PART NO.	DESCRIPTION	ヒョウメイ	Qty
1	#01	D1630-245-EA0-A	THROAT PLATE BASE ASM.	ハリイタ イ(クミ)	1
2	#02	B1630-245-0A0-A	THROAT PLATE BASE ASM.	ハリイタ イ(クミ)	1
3	#03	B1632-245-00A	FEED LIFTING PIN	ジ ヨウゲ オクリビ ン	1
4	#03	B1632-245-00B	VERTICAL FEED PIN	ジ ヨウゲ オクリビ ン	1
5		B1632-245-00C	PIN	ジ ヨウゲ オクリビ ン	1
6	#03	B1632-245-00D	PIN	ジ ヨウゲ オクリビ ン	1
7	#03	B1632-245-00E	PIN	ジ ヨウゲ オクリビ ン	1
8	#02	B1613-245-00E	FEED DOG	オクリ	1
9	#01	D1613-245-E0A	FEED DOG (FOR CLOTH)	オクリ(ヌノヨウ)	1
10	#01	D1606-245-E00	FEED BAR	オクリタ イ	1
11		B1633-245-000	SPRING	オクリタ イハネ	1
12		B1601-245-000	FEED ROCK SHAFT	スィハイオクリシク	1
13		B1654-245-000	FEED DRIVING HOLDER, A	ジ ヨウゲ カムウケイタA	1
14		B1635-245-000	FEED DRIVING CAM HOLDER, B	ジ ヨウゲ カムウケイタB	1
15		B1655-245-000	FEED DRIVING CAM HOLDER WASHER	ジ ヨウゲ カムウケイタガネ	1
16		B1637-245-000	FEED DRIVING CAM HOLDER PLATE	ジ ヨウゲ カムウケイタフタ	1
17		B1638-245-000	SCREW STUD	ハネサエシク	1
18	#02	B1172-245-000	HOOK COVER HOLDER	カマカハ トメ	1
19		B1640-245-000	BED COVER WASHER	オクリタ イシクフタ	1
20		B1641-245-000	HINGE SCREW	オクリタ イシク トメネジ	2
21		B1642-245-000	SPRING	オクリタ イシク トメネジハネ	2
22		B1147-141-H00	PIN	オクリ チヨウセツ ビン	1
23		B1148-141-H00	SPRING	オクリ チヨウセツ ビンハネ	1
24		B1605-245-000	FEED ROCKER SHAFT CRANK	スィハイオクリウデ	1
25		B1614-245-000	PITMAN	フタマタロツト	1
26		B1619-241-H00	FEED CONNECTING LINK	フタマタリツク	1
27		B1620-245-000	FEED REGULATOR	オクリチヨウセツタ イ	1
28		B1622-241-H00	HINGE PIN	オクリチヨウセツタ イ トメシク	1
29		B1650-245-000	FEED REGULATOR SUPPORTING BASE	オクリチヨウセツタ イ トメシク	1
30		B1623-245-0A0	STITCH DIAL ASM.	メモリアタクミ	1
31		B1603-245-000	FEED ROCKER	オクリタ イヨウウウデ	1
32		B1643-145-000	FEED BAR SLIDE BLOCK, A	オクリタ イコマA	1
33		B1644-245-000	FEED BAR SLIDE BLOCK, B	オクリタ イコマB	1
34		B1645-245-000	FEED BAR SLIDE SCREW STUD	オクリタ イコマシク	1
35		B1646-245-000	THRUST COLLAR	スィハイオクリシク スラストウケ	1
36		B1617-241-H00	HINGE SCREW, A	フタマタリツク タンネジ A	1
37		B1618-241-H00	HINGE SCREW, B	フタマタリツク タンネジ B	1
38		B1647-245-000	FEED DRIVING CAM	ジ ヨウゲ カム	1
39		B1639-245-000	FEED BAR SHAFT	オクリタ イシク	1
40		B1424-158-000	HINGE SCREW	ハリネ -エート- オクリウデ タンネジ	1
41		B1634-245-000	STITCH LENGTH REGULATING SCREW	オクリチヨウセツネジ	1
42		B2115-271-000	NEEDLE THROW LINK	フリハハ リツク	1
43		B1636-245-000	BUSHING	オクリチヨウセツネジ メタル	1
44		B1637-141-H00	ECCENTRIC BUSHING	ハンソウ アツツ	1
45		B1638-141-H00	SCREW	オクリチヨウセツネジ メタル トメネジ	4
46		PS-0400182-K0	SPRING PIN 4.0X18	スチリツク ビン 4.0X18	2
47		SD-0640231-SP	HINGE SCREW D= 6.35 H= 2.3	タンネジ D=6.35 H=2.3	2
48		RO-0742401-00	RUBBER RING	Oリング	1
49		RE-0300000-K0	E-RING 3	Eカ タメワ 3	1
50		RE-0700000-K0	E-RING 7	Eカ タメワ 7	1
51		NS-6680320-SP	NUT 9/32-28	ワツカクナツト 9/32-28	1
52		NS-6680410-SP	NUT 9/32-28	ワツカクナツト 9/32-28	1
53		SS-6081210-SP	SCREW 1/8-44 L=12	ヒラネジ 1/8-44 L=12	2
54		B1651-245-000	SCREW	フタマタリツク トメネジ	2
55		SS-6060210-SP	SCREW 3/32-56 L= 1.9	ヒラネジ 3/32-56 L=1.9	1
56		B1652-245-000	SCREW	オクリトメネジ	2
57		B1653-245-000	SCREW	オクリタ イシクフタネジ	1
58		SS-8150710-TP	SCREW 15/64-28 L=7	トメネジ 15/64-28 L=7	1
59		SS-8150830-SP	SCREW	トメネジ 15/64-28 L=8	1
60		SS-5110710-SP	SCREW 11/64-40 L=7	トラスネジ 11/64-40 L=7	1
61		SS-6121050-SP	SCREW 3/16-28 L= 9.5	ヒラネジ 3/16-28 L=9.5	1
62		SS-7151210-SP	SCREW 15/64-28 L=12	マルヒラネジ 15/64-28 L=12	4
63		SS-6151220-SP	SCREW 15/64-28 L=11.5	ヒラネジ 15/64-28 L=11.5	1
64		SS-7151330-SP	SCREW 15/64-28 L=13.0	マルヒラネジ 15/64-28 L=13	1
65		SS-8110410-SP	SCREW 11/64-40 L=3.5	トメネジ 11/64-40 L=6.5	2
66		SS-8701042-TP	SCREW 5/16-24 L=10.0	トメネジ 5/16-24 L=10	1
67		SS-2090810-SP	SCREW 9/64-40 L= 7.5	マルザラネジ 9/40 L=7.5	2
68		SS-7080520-SP	SCREW 1/8-44 L=4.9	マルヒラネジ 1/8-44 L=4.9	2
69		B1175-245-000	SPRING	ハツツヨウモンカハハネ	1
70		SS-6090610-SP	SCREW 9/64-40 L= 5.5	ヒラネジ 9/64-40 L=5.5	2
71	#01	D1172-245-E00	HOOK COVER HOLDER	カマカハ トメ	1
72	#04	B1650-245-00A	FEED REGULATOR SUPPORTING BASE	オクリチヨウセツタ イ トメシク	1
73	#04	B1636-245-00A	BUSHING	オクリチヨウセツネジ メタル	1

NOTE (注記)

#01... FOR DSC-244-4,-6,-7
 #02... FOR DSC-244
 #03... SELECTIVEPART
 #04... FOR URBAN WHITE

DSC-244-4,-6,-7用
 DSC-244用
 選択部品
 アーバンホワイト用

5. REVERSE FEED MECHANISM COMPONENTS

逆送り関係

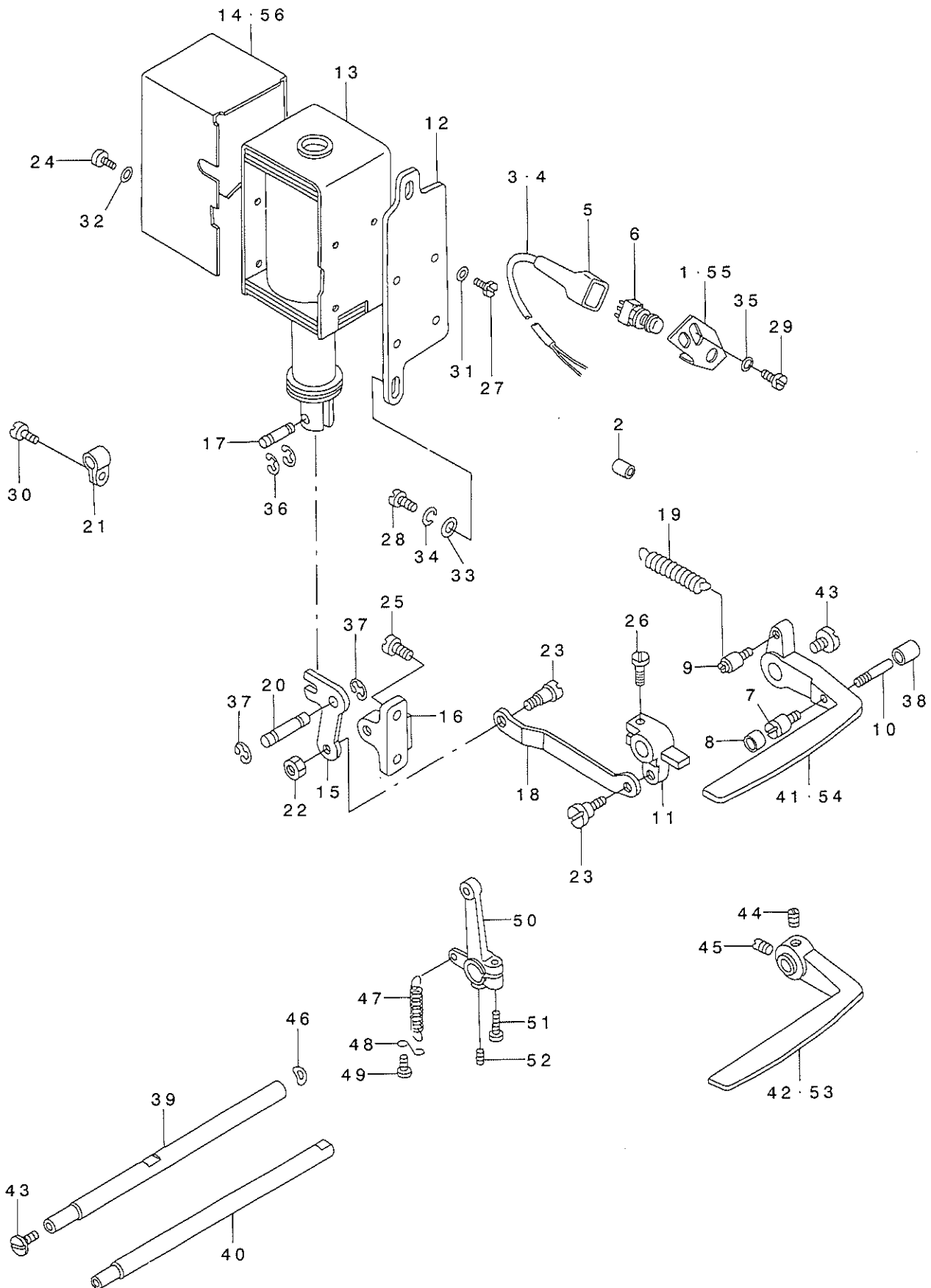

REF. NO	NOTE	PART NO.	DESCRIPTION	ヒョウメイ	Qty
1	#07	D1681-241-E00	SWITCH INSTALLING BASE	スイッチトリツケダ イ	1
2	#01	EA-9570B02-00	TUBE	ネツクユウシク チューブ	2
3	#03	HW-5001400-00	2-C CABLE	キヤブ タイヤコート 0.18X12X2	1
4	#04	HW-5001400-00	2-C CABLE	キヤブ タイヤコート 0.18X12X2	1
5	#01	MAT-81126T00	2-POLE PLUG COVER	2P プラグ カハ	1
6	#01	D1680-141-E00	REVERSE FEED SWITCH	キヤクオクリ スイッチ	1
7	#01	B1114-280-000	PIN	ピン	1
8	#01	101-19907	CUSHION	キヤクオクリレハ - コムク	1
9	#01	101-20004	SPRING SUSPENSION	キヤクオクリレハ - ハネカケ	1
10	#01	B2733-761-000	PIN	ピン	1
11	#01	101-19709	REVERSE FEED CONNECTING ARM	キヤクオクリレソクツウデ	1
12	#01	101-19204	SOLENOID INSTALLING PLATE	マグ ネットトリツケダ イ	1
13	#01	101-19105	REVERSE FEED SOLENOID, AC24V	キヤクオクリマグ ネット 24V	1
14	#07	101-19303	SOLENOID COVER	マグ ネットカハ	1
15	#01	101-19402	LINK	キヤクオクリ フタマタリンク	1
16	#01	D1684-141-E00-A	LINK INSTALLING BASE	キヤクオクリフタマタリンクトリツケダ イ	1
17	#01	D2464-555-B00	LINK DRIVING MAGNET PIN	マグ ネット リンクピン	1
18	#01	D1686-241-E00	REVERSE FEED ROD	キヤク オクリ ロツト	1
19	#01	D1685-141-E00	LEVER SPRING	キヤクオクリ レハ - ハネ	1
20	#01	D1687-141-E00	PIN	フタマタリンク シク	1
21	#01	GES-12155000	CLIP C	ソクセンバント C	4
22	#01	NS-6150430-SP	NUT 15/64-28	ロツカクナツ 15/64-28	1
23	#01	SD-0720331-SP	HINGE SCREW D= 7.24 H= 3.3	ダンネジ D=7.24 H=3.3	2
24	#01	SS-7110710-SP	SCREW 11/64-40 L=7	マルヒラネジ 11/64-40 L=7	1
25	#01	SS-7151210-SP	SCREW 15/64-28 L=12	マルヒラネジ 15/64-28 L=12	2
26	#01	SS-7121410-SP	SCREW 3/16-28 L=14	マルヒラネジ 3/16-28 L=14	1
27	#01	SS-9111010-SP	SCREW 11/64-40 L=9.5	ロツカクネツ 11/64-40 L=9.5	4
28	#01	SS-7151210-SP	SCREW 15/64-28 L=12	マルヒラネジ 15/64-28 L=12	2
29	#01	SS-7110710-SP	SCREW 11/64-40 L=7	マルヒラネジ 11/64-40 L=7	1
30	#01	SS-7110710-SP	SCREW 11/64-40 L=7	マルヒラネジ 11/64-40 L=7	4
31	#01	WP-0501016-SD	WASHER 5X10.5X1	ヒラサ カネ 5X10.5X1	4
32	#01	WP-0501016-SD	WASHER 5X10.5X1	ヒラサ カネ 5X10.5X1	4
33	#01	WP-0621016-SD	WASHER 6.2X13X1	ヒラサ カネ 6.2X13X1	2
34	#01	WS-0631510-KP	SPRING WASHER	ハネサ カネ	2
35	#01	WP-0501016-SD	WASHER 5X10.5X1	ヒラサ カネ 5X10.5X1	2
36	#01	RE-0400000-KO	E-RING 4	Eカ 外メツ 4	2
37	#01	RE-0600000-KO	E-RING 6	Eカ 外メツ 6	2
38	#01	BP-3000000-00	VINYL PIPE	ビニールパイプ	0.1
39	#01	D1621-241-E00	FEED CONTROL LEVER SHAFT	オクリ チョウセツ レハ - シク	1
40	#02	B1621-241-H00	REVERSE FEED CONTROL LEVER SHA	オクリチヨセツレハ - シク	1
41	#07	D1624-241-E00	REVERSE FEED CONTROL LEVER	キヤクオクリ レハ	1
42	#08	B1624-586-000	REVERSE FEED CONTROL LEVER	オクリレハ	1
43		SS-7620750-SP	SCREW 3/16-32 L= 6.5	マルヒラネジ 3/16-32 L=6.5	2
44	#02	SS-8661040-TP	SCREW 1/4-40 L=10	トメネジ 1/4-40 L=10	1
45	#02	SS-8660810-TP	SCREW 1/4-40 L=8	トメネジ 1/4-40 L=8	1
46	#02	WZ-1052010-KP	WAVED WASHER	ナミガ 外サ カネ 10.5X14.5X0.3	1
47		B1646-241-H00	TENSION SPRING	ヒツハ リハネ	1
48		B1648-122-000	SUSPENSION HOOK (B)	ヒツハ リハネカケ B	1
49		SS-7090710-SP	SCREW 9/64-40 L= 6.8	マルヒラネジ 9/64-40 L=6.8	1
50		B1627-241-H00	CONTROL LEVER CRANK	オクリチヨセツウデ	1
51		SS-6121210-SP	SCREW 3/16-28 L=12	ヒラネジ 3/16-28 L=12	1
52		SS-8150710-SP	SCREW 15/64-28 L=7	トメネジ 15/64-28 L=7	1
53	#06	B1624-586-00A	REVERSE FEED CONTROL LEVER	オクリレハ	1
54	#05	D1624-241-E0A	REVERSE FEED CONTROL LEVER	キヤクオクリレハ	1
55	#05	D1681-241-E0A	SWITCH INSTALLING BASE	スイッチトリツケダ イ	1
56	#05	101-61305	SOLENOID COVER	マグ ネットカハ	1

NOTE (注記)

#01...	FOR DSC-244-4-1B,-4-1B(JE), -6-0B,-7-0B	DSC-244-4-1B,-4-1B(JE), -6-0B,-7-0B用
#02...	FOR DSC-244,-4-1,-4-1(JE), -6-00,-7-00	DSC-244,-4-1,-4-1(JE), -6-00,-7-00用
#03...	FOR DSC-244-4-1B,-4-1B(JE), -7-0B,-7-0B(JE)	DSC-244-4-1B,-4-1B(JE), -7-0B,-7-0B(JE)用
#04...	FOR DSC-244-6-0B	DSC-244-6-0B用
#05...	FOR DSC-244-4-1B(URBAN WHITE), -7-0B	DSC-244-4-1B(7-ハ ソホワイト), -7-0B用
#06...	FOR DSC-244(URBAN WHITE), -4-1(URBAN WHITE),-7-00	DSC-244(7-ハ ソホワイト), -4-1(7-ハ ソホワイト),-7-00用
#07...	FOR DSC-244-4-1B,-4-1B(JE), -6-0B	DSC-244-4-1B,-4-1B(JE), -6-0B用
#08...	FOR DSC-244,-4-1,-4-1(JE),-6-00	DSC-244,-4-1,-4-1(JE),-6-00用

6. UPPER FEED MECHANISM & HOOK DRIVING SHAFT COMPONENTS

上送り・下軸関係

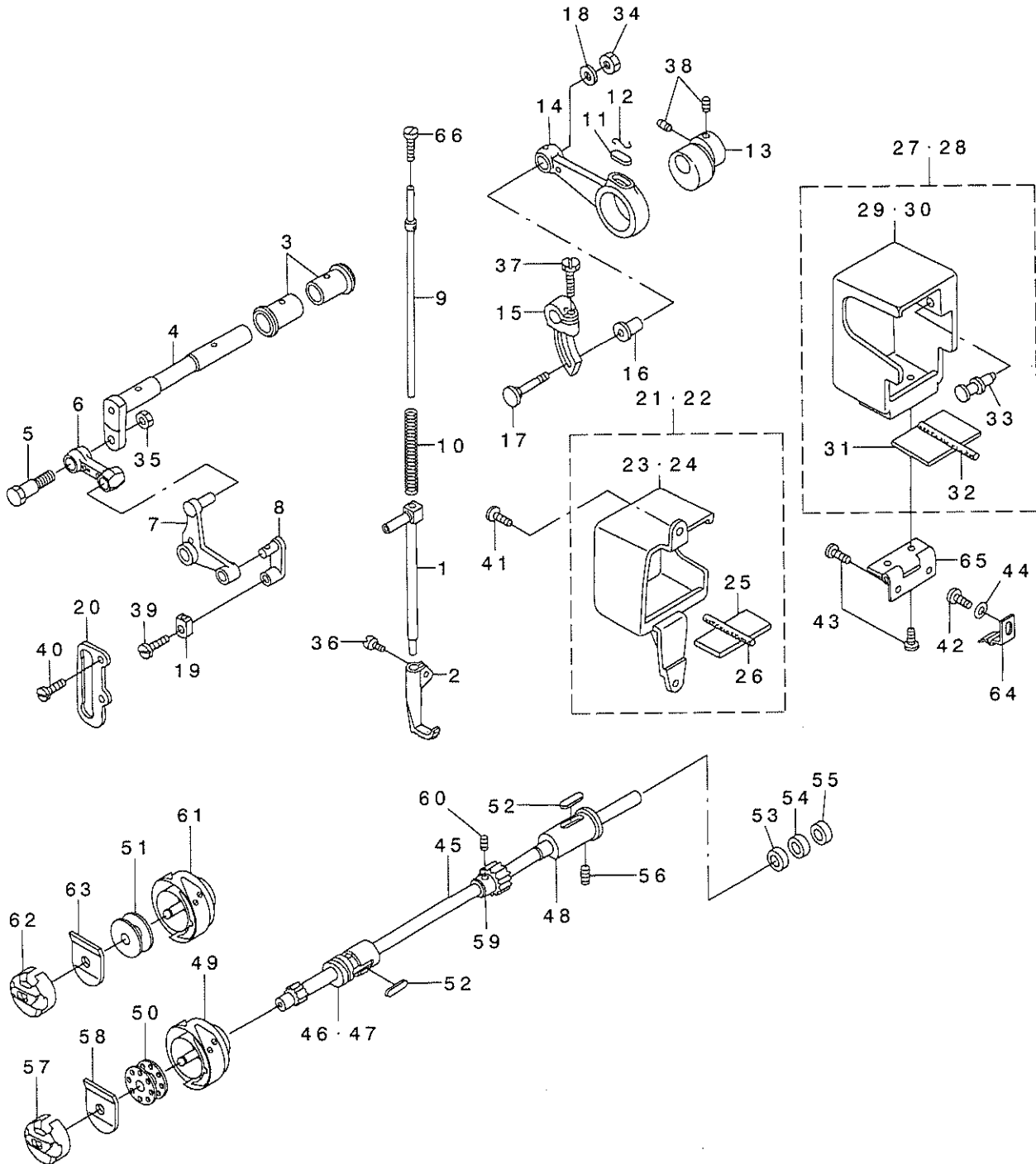

REF. NO	NOTE	PART NO.	DESCRIPTION	ヒソメイ	Qty
1		B1466-563-000	WALKING BAR	ウエオクリホウ	1
2		B1470-245-000	WALKING FOOT	ウオオクリアシ	1
3		B1455-053-000	BUSHING	ウオオクリシクメタル	2
4		103-14003	UPPER FEED DRIVING SHAFT	ウオオクリシク	1
5		B3008-141-H00	HINGE SCREW	カムロツトダシネジ	1
6		D1458-241-E00	CONNECTING LINK	ウオオクリレンケツリンク	1
7		D1459-241-E00	L SHAPED LINK	Lカクタリンク	1
8		103-14508	WALKING BAR DRIVING LINK	ウオオクリヨートリンク	1
9		B1467-053-0A0	WALKING BAR ASM.	ウオオクリカハネシクホクミ	1
10		B1468-053-000	WALKING BAR SPRING	ウオオクリホウオサエハネ	1
11		B1702-012-000	OIL FELT	フェルト	1
12		B1213-012-000	FELT RETAINER	フェルトオサエ	1
13		D1450-055-B00	UPPER FEED DRIVING CAM	ウオオクリカム	1
14		D1453-241-E00	UPPER FEED DRIVING ROD	ウオオクリロツト	1
15		B1454-245-000	UPPER FEED SPRING ROD	ウオオクリウヂ	1
16		D1455-055-B00	CONNECTING STUD	ウオオクリロツトレンケツシク	1
17		D1456-055-B00	HINGE SCREW	ウオオクリロツトダシネジ	1
18		WP-0482086-SD	WASHER 4.8X11.5X2	ヒラサカネ4.8X11.5X2	1
19		B1414-555-000	SLIDE BLOCK	ハリホウダキアンナイコロ	1
20		B1467-563-000	UPPER FEED BAR GUIDE	ウオオクリホウウガイト	1
21		D1480-241-EA0	UPPER FEED FRONT COVER ASM.	ウオオクリカハマエクミ	1
22	#04	D1480-241-EAA	UPPER FEED FRONT COVER ASM.	ウオオクリカハマエ(クミ)	1
23		D1480-241-E00	UPPER FEED FRONT COVER	ウオオクリカハマエ	(1)
24	#04	D1480-241-E0A	UPPER FEED FRONT COVER	ウオオクリカハマエ	(1)
25		D1481-241-E00	FELT	ウオオクリカハフェルト(マエ)	(1)
26		CQ-3030000-00	OIL WICK	ユツシ	(0.2)
27		D1482-241-EA0	UPPER FEED REAR COVER ASM.	ウオオクリカハウシロクミ	1
28	#04	D1482-241-EAA	UPPER FEED REAR COVER ASM.	ウオオクリカハウシロ(クミ)	1
29		D1482-241-E00	UPPER FEED REAR COVER	ウオオクリカハ(ウシロ)	(1)
30	#04	D1482-241-E0A	UPPER FEED REAR COVER	ウオオクリカハウシロ	(1)
31		D1483-241-E00	FELT	ウオオクリカハフェルト(ウシロ)	(1)
32		CQ-3030000-00	OIL WICK	ユツシ	(0.2)
33		D1484-241-E00	PIN	ウオオクリカハイタハネピン	(1)
34		NS-6110530-SP	NUT 11/64-40	ロツカクナツト11/64-40	1
35		NS-6660430-SP	NUT 1/4-40	ロツカクナツト1/4-40	1
36		SS-6110710-SP	SCREW 11/64-40 L=7	ヒラネジ	1
37		SS-9161610-SP	SCREW 1/4-24 L=16	ロツカクホルト1/4-24 L=16	1
38		SS-8660610-TP	SCREW 1/4-40 L=6	トメネジ1/4-40 L=6	2
39		SS-7110510-SP	SCREW 11/64-40 L=5	マルヒラネジ11/64-40 L=5	1
40		SS-7110910-SP	SCREW 11/64-40 L=8.5	マルヒラネジ11/64-40 L=8.5	2
41		SS-7111120-SP	SCREW 11/64-40 L=10.5	マルヒラネジ11/64-40 L=10.5	2
42		SS-7110710-SP	SCREW 11/64-40 L=7	マルヒラネジ11/64-40 L=7	1
43		SS-7110710-SP	SCREW 11/64-40 L=7	マルヒラネジ11/64-40 L=7	4
44		WP-0450000-SD	WASHER 4.5X8X0.5	ヒラサカネ4.5X8X0.5	1
45		213-02104	ROTATING HOOK SHAFT	シモシク	1
46		211-36205	BUSHING, FRONT	シタシクマエメタル	1
47	#01	211-36304	BUSHING, FRONT	シタシクマエメタル	1
48		211-36403	BUSHING, REAR	シタシクアトメタル	1
49		B1830-245-0A0	HOOK ASM.	カマ	1
50	#03	B9117-012-000	BOBBIN	ホピン	1
51	#02	B9117-552-A00	BOBBIN	ホピン	1
52		B1806-038-000	OIL FELT	シタシクウシロメタルフェルト	2
53	#01	B1839-245-00A	THRUST PLATE	シモシクストラストイタ	1
54		B1839-245-00B	THRUST PLATE	シモシクストラストイタ	1
55	#01	B1839-245-00C	THRUST PLATE	シモシクストラストイタ	1
56		SS-8151550-SP	SCREW 15/64-28 L=15	トメネジ15/64-28 L=15	1
57		B1837-245-0A0	BOBBIN CASE ASM.	ホピンケース	1
58	#03	B1838-245-000	SPRING	クウチンホウシハネ	1
59		D2405-245-E00	CAM SHAFT GEAR	カムシクキヤ	1
60		SS-8660530-TP	SCREW 1/4-40 L=4.5	トメネジ1/4-40 L=4.5	2
61	#02	212-09952	SEWING HOOK ASM.	カマ(クミ)	1
62	#02	212-10059	BOBBIN CASE ASM.	ホピンケース(クミ)	1
63	#02	212-10901	IDLING PREVENTION SPRING	クウチンホウシハネ	1
64		D1485-241-E00	UPPER FEED COVER SPRING	ウオオクリカハイタハネ	1
65		D1486-241-E00	UPPER FEED COVER HINGE	ウオオクリカハチヨウツガイ	1
66		SS-6151220-SP	SCREW 15/64-28 L=11.5	ヒラネジ15/64-28 L=11.5	1

NOTE (注記)

#01...SELECTIVE PART
 #02...FOR DSC-244-4,-6,-7
 #03...FOR DSC-244
 #04...FOR URBAN WHITE

選択部品
 DSC-244-4,-6,-7用
 DSC-244用
 アーバンホワイト用

7. THREAD TRIMMER COMPONENTS

糸切り関係

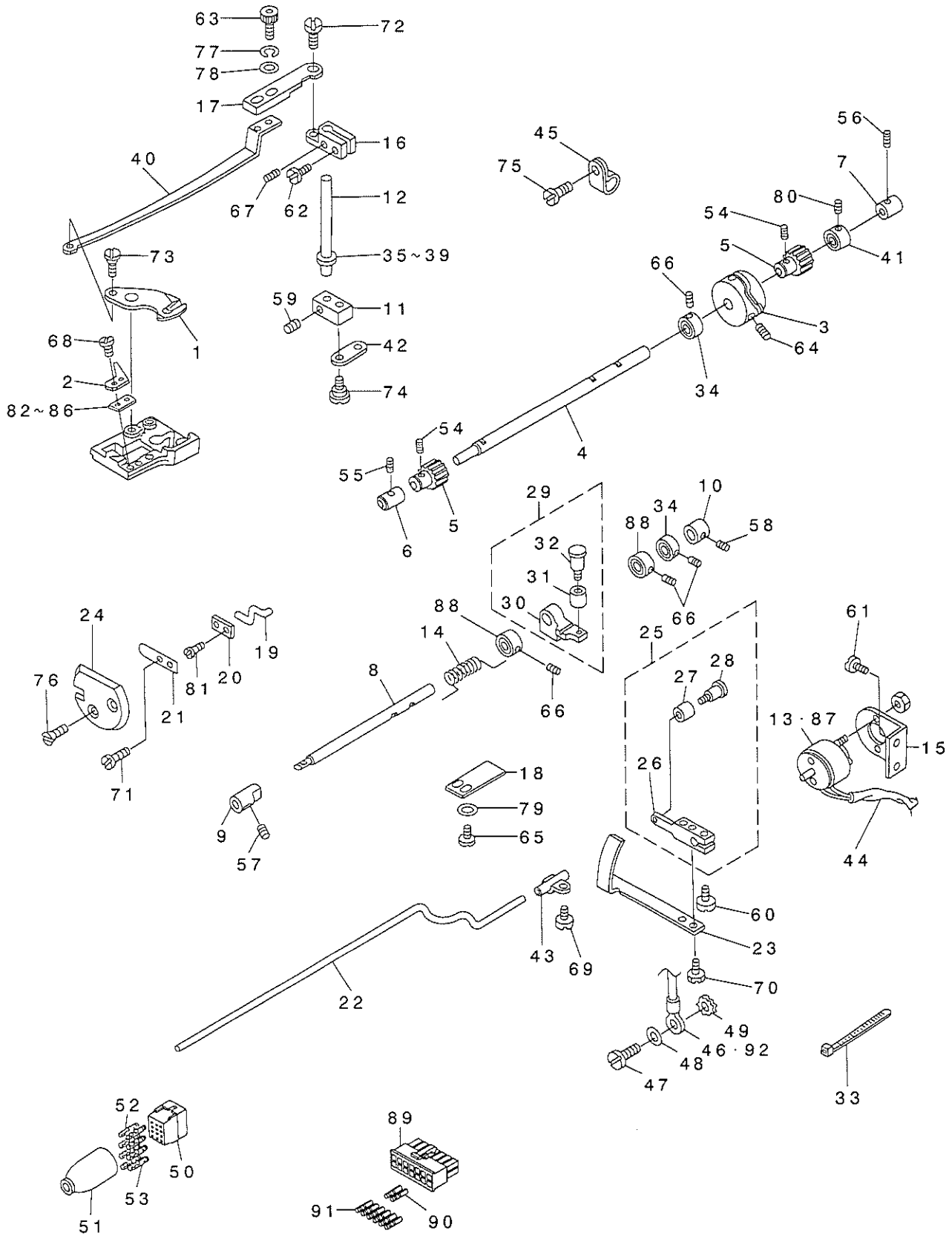

REF. NO	NOTE	PART NO.	DESCRIPTION	キヨメイ	Qty
1	#01	D2401-245-E00	MOVING KNIFE	トウメス	1
2	#01	D2402-245-E00	COUNTER KNIFE	コチメス	1
3	#01	D2403-245-E00	THREAD TRIMMER CAM	トキリカム	1
4	#01	D2404-245-E00	CAM SHAFT	カムシャフト	1
5	#01	D2405-245-E00	CAM SHAFT GEAR	カムシャフトギヤ	2
6	#01	D2406-245-E0A	HOOK SHAFT BUSHING, FRONT	フックシャフトブッシング	1
7	#01	211-36601	CAM SHAFT BUSHING, REAR	カムシャフトブッシング	1
8	#01	D2409-245-E00	DRIVING SHAFT, A	トキリシャフトウグA	1
9	#01	D2410-245-E00	BUSHING, FRONT	トキリシャフトウグAブッシング	1
10	#01	D2411-245-E00	BUSHING, REAR	トキリシャフトウグBブッシング	1
11	#01	D2412-245-E00	KNIFE DRIVING SHAFT ARM, A	メスグドウグウグA	1
12	#01	D2413-245-E00	DRIVING SHAFT, B	トキリシャフトウグB	1
13	#03	D2414-245-E00	SOLENOID	トキリソレノイド	1
14	#01	D2416-245-E00	SPRING	スプリング	1
15	#01	D2418-245-E00	SOLENOID BASE	トキリソレノイドコチハン	1
16	#01	D2419-245-E00	KNIFE DRIVING LINK, B	メスグドウグB	1
17	#01	D2420-245-E00	KNIFE DRIVING PLATE, B	メスグドウグB	1
18	#01	D2421-245-E00	CAM ROLLER ARM HOLDER	カムコロウグホルダ	1
19	#01	D2424-245-E00	PICKER	ピッカー	1
20	#01	D2425-245-E00	PICKER HOLDER PLATE	ピッカーホルダプレート	1
21	#01	D2426-245-E00	SPRING	ピッカーホルダプレート	1
22	#01	D2427-245-E00	PICKER DRIVING BAR	ピッカードライブバー	1
23	#01	D2428-245-E00	PICKER DRIVING PLATE	ピッカードライブプレート	1
24	#01	D2429-245-E00	PICKER COVER	ピッカーカバー	1
25	#01	D2415-245-EA0	SOLENOID ARM ASM.	トキリソレノイドウグ	1
26	#01	D2415-245-E00	SOLENOID ARM	トキリソレノイドウグ	(1)
27		B3031-141-H00	CONNECTING STUD	ダキカイトコ	(1)
28		D2423-245-E00	CAM ROLLER ARM	カムコロウグ	(1)
29	#01	D2417-245-EA0	CAM ROLLER ARM ASM.	カムコロウグ	1
30		D2417-245-E00	CAM ROLLER ARM	カムコロウグ	(1)
31		B3031-141-H00	CONNECTING STUD	ダキカイトコ	(1)
32		D2423-245-E00	CAM ROLLER ARM	カムコロウグ	(1)
33	#01	GES-12153000	OIL WICK HOLDER	ソクセンハントA	5
34	#01	D2432-245-E00	THRUST COLLAR	スラストウグ	2
35	#02	B1853-512-00A-A	HOOK SHAFT WASHER, A	カムシャフトワッシャーA	1
36	#02	B1853-512-00B-A	HOOK SHAFT WASHER, B	カムシャフトワッシャーB	1
37	#01	B1853-512-00C-A	HOOK SHAFT WASHER, C	カムシャフトワッシャーC	1
38	#02	B1853-512-00D	HOOK SHAFT WASHER	カムシャフトワッシャー	1
39	#02	B1853-512-00E	HOOK SHAFT WASHER	カムシャフトワッシャー	1
40	#01	D2431-245-E00	KNIFE DRIVING PLATE, A	メスグドウグA	1
41	#01	D1841-141-E00	THRUST COLLAR	スラストウグ	1
42	#01	D2436-141-E00	CONNECTING LINK	メスグドウグクレンクリンク	1
43	#01	D2430-245-EA0	PICKER DRIVING BAR HOLDER ASM.	ピッカードライブバーホルダ	1
44	#01	D2428-141-E00	CORD TUBE 5X0.4	コードチューブ(5X0.4)	1
45	#01	D2120-555-C00	CORD PRESSER (120V)	ナイロンクラッパ	4
46	#04	B6037-505-0A0	GROUND WIRE ASM.	アースコード(タミ)	1
47	#01	SS-7110710-SP	SCREW 11/64-40 L=7	マルヒラネジ 11/64-40 L=7	1
48	#01	WP-0501016-SD	WASHER 5X10.5X1	ヒラネジ 5X10.5X1	1
49	#01	WT-0530002-KS	TOOTHED WASHER D=5.3	ハツキネジ 5.3	1
50	#04	M9640-110-000	12-POLE PLUG	ナロンプラグ 12P	1
51	#04	M9637-110-000	12-POLE PLUG COVER	プラグカバー 12P	1
52	#05	B6043-555-B00	PIN TERMINAL, MALE	ピンターミナルオス	2
53	#06	B6043-555-B00	PIN TERMINAL, MALE	ピンターミナルオス	6
54	#01	SS-8660530-TP	SCREW 1/4-40 L=4.5	トメネジ 1/4-40 L=4.5	4
55	#01	SS-8151230-SP	SCREW 15/64-28 L=12	トメネジ 15/64-28 L=12	1
56	#01	SS-8151230-SP	SCREW 15/64-28 L=12	トメネジ 15/64-28 L=12	1
57	#01	SS-8151230-SP	SCREW 15/64-28 L=12	トメネジ 15/64-28 L=12	1
58	#01	SS-8151230-SP	SCREW 15/64-28 L=12	トメネジ 15/64-28 L=12	1
59	#01	SS-7110540-SP	SCREW 11/64-40 L=5	マルヒラネジ 11/64-40 L=5	2
60	#01	SS-7110910-SP	SCREW 11/64-40 L=8.5	マルヒラネジ 11/64-40 L=8.5	1
61	#01	SS-7110910-SP	SCREW 11/64-40 L=8.5	マルヒラネジ 11/64-40 L=8.5	2
62	#01	SS-7111410-TP	SCREW 11/64-40 L=14	マルヒラネジ 11/64-40 L=14	1
63	#01	SS-7091410-SP	SCREW 9/64-40 L=13.5	マルヒラネジ 9/64-40 L=13.5	2
64	#01	SS-8660612-TP	SCREW 1/4-40 L=6	トメネジ 1/4-40 L=6	2
65	#01	SS-6090810-SP	SCREW 9/64-40 L=7.5	ヒラネジ 9/64-40 L=7.5	2
66	#01	D2434-245-E00	SCREW	スラストウグネジ	8
67	#01	SS-8090410-SP	SCREW 9/64-40 L=3.5	トメネジ 9/64-40 L=3.5	1
68	#01	SS-7060310-SP	SCREW 3/32-56 L=3	マルヒラネジ 3/32-56 L=3	2
69	#01	SS-7110710-SP	SCREW 11/64-40 L=7	マルヒラネジ 11/64-40 L=7	1
70	#01	SS-9091010-SP	SCREW 9/64-40 L=10	ロウカクネジ 9/64-40 L=10	2
71	#01	SS-5060310-SP	SCREW 3/32-56 L=2.8	トメネジ 3/32-56 L=2.8	2
72	#01	D2433-245-E00	HINGE SCREW	メスグドウグネジ	1
73	#01	SD-0640321-SP	HINGE SCREW D=6.35 H=3.2	ダウネジ D=6.35 H=3.2	1
74	#01	D2441-141-E00	HINGE SCREW	メスグドウグクレンクリンクネジ	1
75	#01	SS-7110710-SP	SCREW 11/64-40 L=7	マルヒラネジ 11/64-40 L=7	1
76	#01	D2436-245-E00	SCREW	ピッカーホルダネジ	2
77	#01	WS-0410002-KN	SPRING WASHER	ハネネジ 3.7X7X1	2
78	#01	WP-0371026-SD	WASHER 3.7X7X1	ヒラネジ 3.7X7X1	2
79	#01	WP-0371026-SD	WASHER 3.7X7X1	ヒラネジ 3.7X7X1	2
80	#01	SS-8660410-SP	SCREW 1/4-40 L=4.2	トメネジ 1/4-40 L=4.2	2
81	#01	D2435-245-E00	SCREW	ピッカーホルダネジ	2
82	#02	212-12600	SUPPORT PLAT	メスアブチヨウセツイタ	1
83	#02	212-12709	SUPPORT PLAT	メスアブチヨウセツイタ	1
84	#01	212-12808	SUPPORT PLAT	メスアブチヨウセツイタ	1
85	#02	212-12907	SUPPORT PLAT	メスアブチヨウセツイタ	1
86	#02	212-13004	SUPPORT PLAT	メスアブチヨウセツイタ	1
87	#04	D2414-245-E0A	SOLENOID	トキリソレノイド	1
88	#01	D2432-245-E0A	THRUST COLLAR A	スラストウグA	2
89	#07	HK-0346101-40	HOUSING 14P	ハウジング 14P	1
90	#08	HK-0346400-0B	PIN CONTACT	ピンコンタクト	2
91	#09	HK-0346400-0E	PIN CONTACT	ピンコンタクト	6
92	#07	D6037-245-GA0	GROUND WIRE ASM.	アースコード(タミ)	1

NOTE (注記)

- #01... FOR DSC-244-4,-6,-7
- #02... SELECTIVE PART FOR DSC-244-4,-6
- #03... FOR DSC-244-4,-7
- #04... FOR DSC-244-6
- #05... FOR DSC-244-6-00
- #06... FOR DSC-244-6-0B
- #07... FOR DSC-244-7
- #08... FOR DSC-244-7-00
- #09... FOR DSC-244-7-0B

8. THREAD TENSION COMPONENTS

糸調子関係

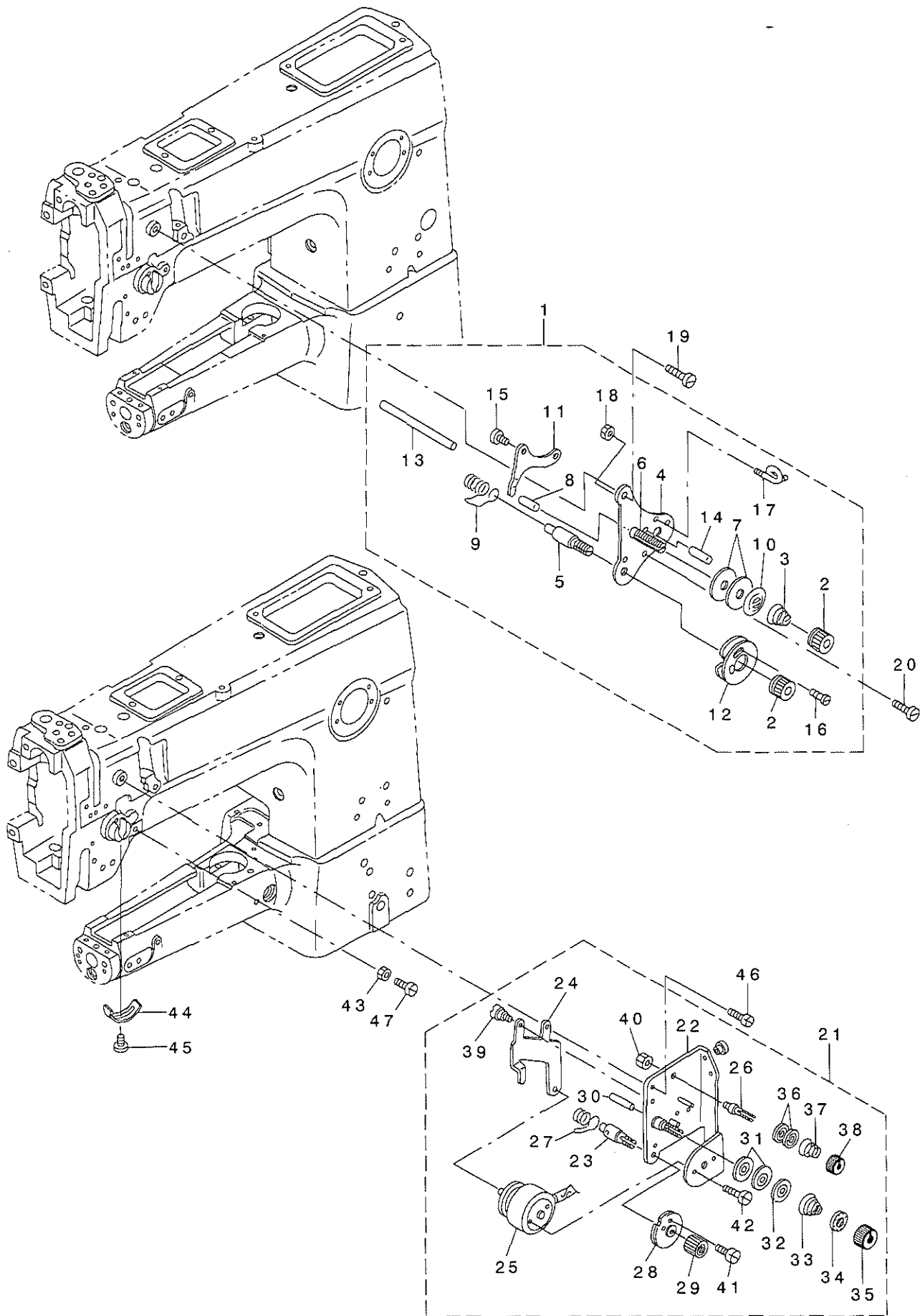

REF. NO	NOTE	PART NO.	DESCRIPTION	品名	Qty
1	#01	B3121-245-0AO	TENSION CONTROLLER ASM.	イトチヨウシクミ	1
2		B3125-012-000	THREAD TENSION NUT	イトチヨ-シ ナツト	(2)
3		B3129-053-000	TENSION SPRING	イトチヨ-シハネ	(1)
4		B3421-245-000	CHAIN	ヒザ アケ ヨウクサリ	(1)
5		B3123-051-000	TAKE-UP SPRING STUD	イトトリ ハネジク	(1)
6		B3124-051-000	TENSION STUD	イトチヨ-シホ-	(1)
7		B3126-051-000	TENSION DISC	イトチヨ-シ サラ	(2)
8		B3127-051-000	TENSION RELEASE PIN, SHORT	イトユルメ ビン	(1)
9		B3128-051-000	THREAD TAKE-UP SPRING, A	イトトリハネ	(1)
10		B3132-051-000	TENSION DISC HOLDER	イトチヨ-シサラ オサエ	(1)
11		B3134-051-000	TENSION RELEASE LEVER	イトユルメ イタ	(1)
12		B3137-051-0AO	TAKE-UP SPRING GUIDE DISC ASM.	イトトリハネ アンナイザラ クミ	(1)
13		B3122-053-000	TENSION RELEASE BAR	イトユルメ オソホ-	(1)
14		PS-0200122-KO	SPRING PIN 2.OX12	スア リンク ビン 2.OX12	(1)
15		SD-0470281-SP	HINGE SCREW D=4.7 H=2.8	タ'ンネジ D=4.7 H=2.8	(2)
16		SS-4080610-SP	SCREW 1/8-44 L=6.4	ナハネジ 1/8-44 L=6.4	(1)
17		B3114-761-000	FRAME THREAD GUIDE B	イトアンナイ B	(1)
18		NS-6060350-SP	NUT 3/32-56	ロツカクナツト 3/32-56	(1)
19	#01	SS-7110710-SP	SCREW 11/64-40 L=7	マルヒラネジ 11/64-40 L=7	1
20	#01	SS-2090710-SP	SCREW 9/64-40 L=7	マルサラネジ 9/64-40 L=7	1
21	#02	103-20075	TENSION POST ASM.	イトチヨ-シ クミ	1
22		103-20059	TENSION POST BASE ASM.	イトチヨウシイタ クミ	(1)
23		103-20109	SCREW STUD	イトトリハネジク	(1)
24		103-20505	TENSION RELEASE LEVER	イトユルメイタ	(1)
25		103-20703	TENSION RELEASE SOLENOID	イトユルメ ソレノイド	(1)
26		101-24204	THREAD TENSION POST, A	タ'イ1イトチヨ-シホ- A	(1)
27		B3128-051-000	THREAD TAKE-UP SPRING, A	イトトリハネ	(1)
28		B3137-527-0AO	TAKE-UP SPRING GUIDE ASM.	イトトリハネ アンナイ クミ	(1)
29		103-20208	THRED TENSION STUD NUT	イトトリハネジクナツト	(1)
30		B3127-051-000	TENSION RELEASE PIN, SHORT	イトユルメ ビン	(1)
31		B3126-051-000	TENSION DISC	イトチヨ-シ サラ	(2)
32		B3132-051-000	TENSION DISC HOLDER	イトチヨ-シサラ オサエ	(1)
33		B3129-053-000	TENSION SPRING	イトチヨ-シハネ	(1)
34		B3120-125-000	ROTATING STOPPER	イトチヨ-シサラ カイテントメ	(1)
35		110-72204	TENSION NUT	イトチヨウシ ナツト	(1)
36		B3214-047-000	BOBBIN WINDER TENSION DISC	イトチヨ-シ サラ	(2)
37		D3168-555-HOB	SPRING	タ'イ1 イトチヨウシハネ	(1)
38		110-72402	THREAD TENSION NUT	タ'イ1 イトチヨウシ ナツト	(1)
39		SD-0470281-SP	HINGE SCREW D=4.7 H=2.8	タ'ンネジ D=4.7 H=2.8	(2)
40		NS-6110310-SP	NUT 11/64-40	ロツカクナツト 11/64-40	(1)
41		SS-3090710-TP	SCREW 9/64-40 L=7	マルネジ 9/64-40 L=7	(1)
42		SS-7110570-SP	SCREW 11/64-40 L= 4.8	マルヒラネジ 11/64-40 L=4.8	(2)
43	#02	NS-6110350-SP	NUT 11/64-40	ロツカクナツト 11/64-40	1
44		B3138-512-000	TAKE-UP SPRING ADJUSTING PLATE	イトトリハネ アンナイ チヨ-セツハン	1
45		SS-7090520-SP	SCREW 9/64-40 L= 4.5	マルヒラネジ 9/64-40 L=4.5	1
46	#02	SS-7110710-SP	SCREW 11/64-40 L=7	マルヒラネジ 11/64-40 L=7	2
47	#02	SS-6111140-SP	SCREW 11/64-40 L=11	ヒラネジ 11/64-40 L=11	1
NOTE (注記)			#01...FOR DSC-244	DSC-244用	
			#02...FOR DSC-244-4,-6,-7	DSC-244-4,-6,-7用	

9. LUBRICATION COMPONENTS

給油関係

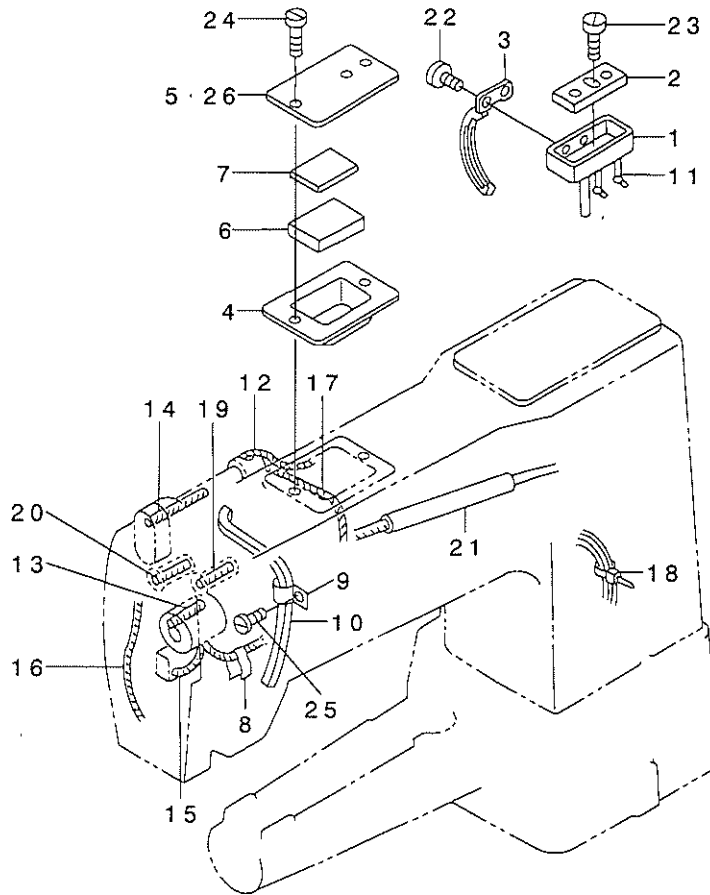

REF. NO	NOTE	PART NO.	DESCRIPTION	品名	Qty
1		B8217-241-H00	OIL RESERVOIR	アア'ラタ'マリ	1
2		B8218-241-H00	OIL PAD	アア'ラタ'マリ フェルト	1
3		B3502-115-000	OIL WICK RETAINER	ユツンササエカナク	1
4		D3501-241-E00	OIL TANK	オイル タンク	1
5		D3502-241-E00	OIL TANK COVER	タンクカバー	1
6		D3503-241-E00	FELT	タンク フェルト	1
7		D3504-241-E00	OIL SPONGE	カンリユウ コ' ミヨク	1
8		B1437-051-000	OIL WICK RETAINER	ヨ-ト' - セ'ンア'ウチ' ユツンササエ	1
9		B3508-512-000	OIL FELT HOLDER	カンリユ- フェルト A オサエ	1
10		211-36908	FELT	カンリユウフェルト	1
11		CQ-2020000-00	OIL WICK	ユツン	0.4
12		CQ-2020000-00	OIL WICK	ユツン	0.1
13		CQ-2020000-00	OIL WICK	ユツン	0.2
14		CQ-2020000-00	OIL WICK	ユツン	1
15		CQ-2020000-00	OIL WICK	ユツン	0.2
16		CQ-2020000-00	OIL WICK	ユツン	1
17		CQ-2020000-00	OIL WICK	ユツン	0.1
18		EA-9500B01-00	CABLE BAND	ソクセンバ'ント'	3
19		D3505-241-E00	OIL WICK	デンビ'ン ササエジ'ク ユツン A	1
20		CQ-2520000-00	OIL WICK	ユツン	0.1
21		BP-8000000-00	VINYL TUBE, WHITE D=8	ビ'ニ-ル ハ'イア' 8	0.4
22		SS-7080510-TP	SCREW 1/8-44 L=4.5	マルヒラネジ' 1/8-44 L=4.5	2
23		SS-7111810-SP	SCREW 11/64-40 L=18	マルヒラネジ' 11/64-40 L=18	1
24		SS-7111120-SP	SCREW 11/64-40 L=10.5	マルヒラネジ' 11/64-40 L=10.5	2
25		SS-7110710-SP	SCREW 11/64-40 L=7	マルヒラネジ' 11/64-40 L=7	1
26	#01	D3502-241-E0A	OIL TANK COVER	タンクカバー	1

NOTE (注記)

#01...FOR URBAN WHITE

ア-ハンホワイト用

10. KNEE LIFTER COMPONENTS

膝上げ関係

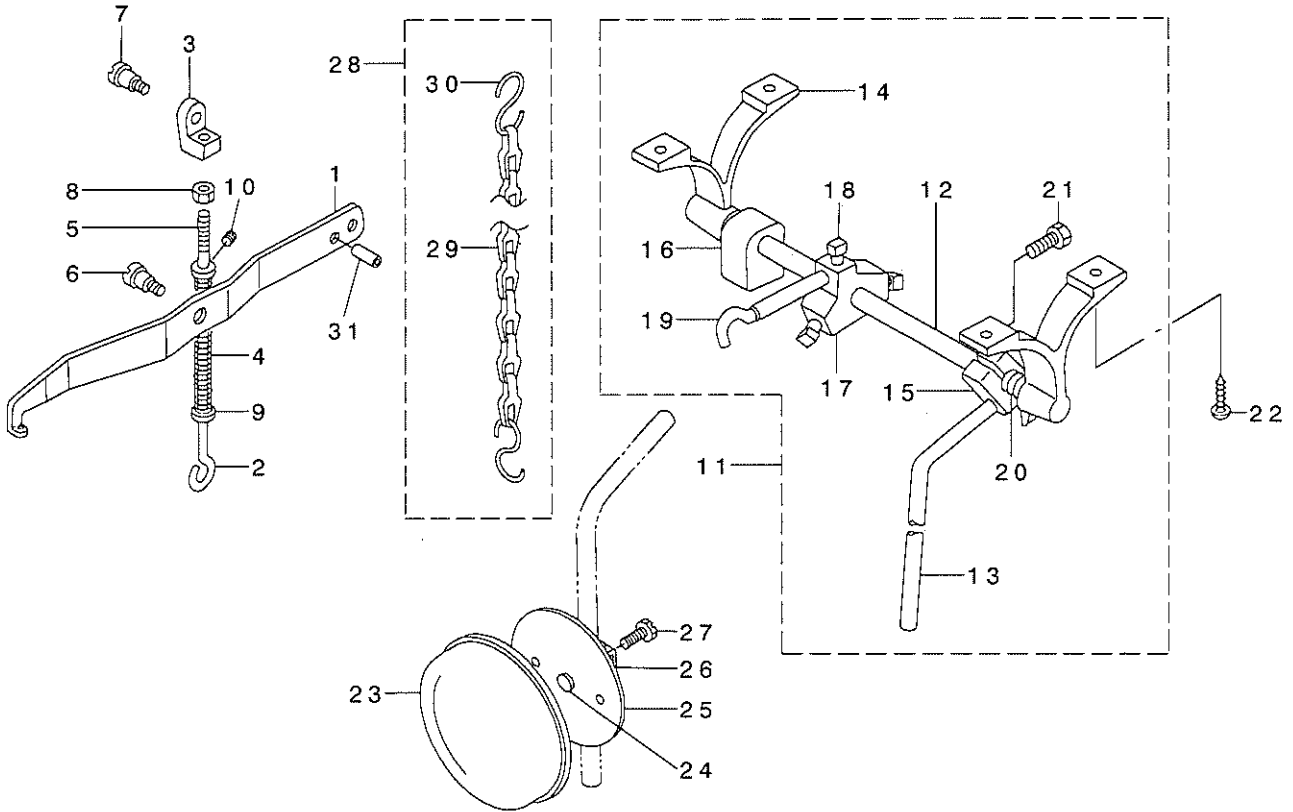

REF. NO	NOTE	PART NO.	DESCRIPTION	品名	Qty
1		D3410-241-E00	PRESSER BAR LIFTING LEVER	ヒサ' アケ' テコ	1
2		B3425-245-000	KNEE LIFTER ARM	ヒサ' アケ' カイテントメハ' ネ	1
3		B3416-141-H00-A	SWIVEL	ツリ ホ' ウ' タ' ルマ	1
4		B3414-245-000	SPRING	ウツロツリホ' ウオシハ' ネ	1
5		B3418-245-000	SPRING HOLDER	ヒサ' アケ' テコハ' ネウケ	1
6		SD-0790361-SP	HINGE SCREW D= 7.94 H= 3.6	タ' ソネジ' D=7.94 H=3.6	1
7		SD-0790351-SP	HINGE SCREW D=7.9 H=3.5	タ' ソネジ' D=7.9 H=3.5	1
8		NS-6620310-SP	NUT 3/16-32	ロツカクナツト 3/16-32	1
9		WP-0621016-SD	WASHER 6.2X13X1	ヒラサ' カ' ネ 6.2X13X1	1
10		SS-7110730-SP	SCREW 11/64-40 L= 6.5	マルヒラネジ' 11/64-40 L=6.5	1
11		B3420-245-0A0	KNEE LIFTER ASM.	ヒサ' アケ' ソウチクミ	1
12		B3420-245-000	MAIN SHAFT	シユジ' ク	(1)
13		B3422-245-000	KNEE LIFTER PLATE ROD	ヒサ' アケ' タチシ' ク	(1)
14		B3423-245-000	KNEE PRESS ROD HOLDER	ササエ	(2)
15		B3433-141-H0A	BRACKET	ヒサ' アケ' タチシ' ク' トリツケウテ'	(1)
16		B3434-141-H00	BRACKET	トメタ' ルマ	(1)
17		B3424-141-H00	MOUNTING BRACKET	マカ' リウテ' ササエ' タ' ルマ	(1)
18		B3425-141-H00	MOUNTING BRACKET SET SCREW	トメネジ'	(3)
19		B3424-245-000	KNEE LIFTER PLATE ARM	マカ' リウテ'	(1)
20		B3425-245-000-A	SPRING	ヒサ' アケ' カイテントメハ' ネ	(1)
21		SS-9182010-SN	SCREW 9/32-20 L=20	ロツカクネ' ルト 9/32-20 L=20	(2)
22		SK-1483200-SE	WOOD SCREW D=4.8 L=32	サラモクネジ' D=4.8 L=32	4
23		B3431-552-000-A	KNEE PRESS PLATE COVER	ヒサ' アケ' カハ' -	1
24		110-24403	RUBBER	ヒサ' アケ' コ' ム	1
25		110-23702	KNEE PRESS PLATE	ヒサ' アケ' カハ'	1
26		110-23801	KNEE PRESS PLATE HOLDER	ヒサ' アケ' ササエ	1
27		SS-9151540-SR	SCREW 15/64-28 L=15	ロツカクネ' ルト 15/64-28 L=15	1
28		B3421-245-0A0	CHAIN ASM.	ヒサ' アケ' ヨウクサリクミ	1
29		B3421-245-000	CHAIN	ヒサ' アケ' ヨウクサリ	(1)
30		B8133-019-000	S SHAPED HOOK	Sガ' タ' カナケ'	(2)
31		PS-0600241-00	SPRING PIN 6X24	スア' リンク' ビ' ッ 6.0X24	1

11. BELT COVER & THREAD WINDER COMPONENTS

ベルトカバー・糸巻き関係

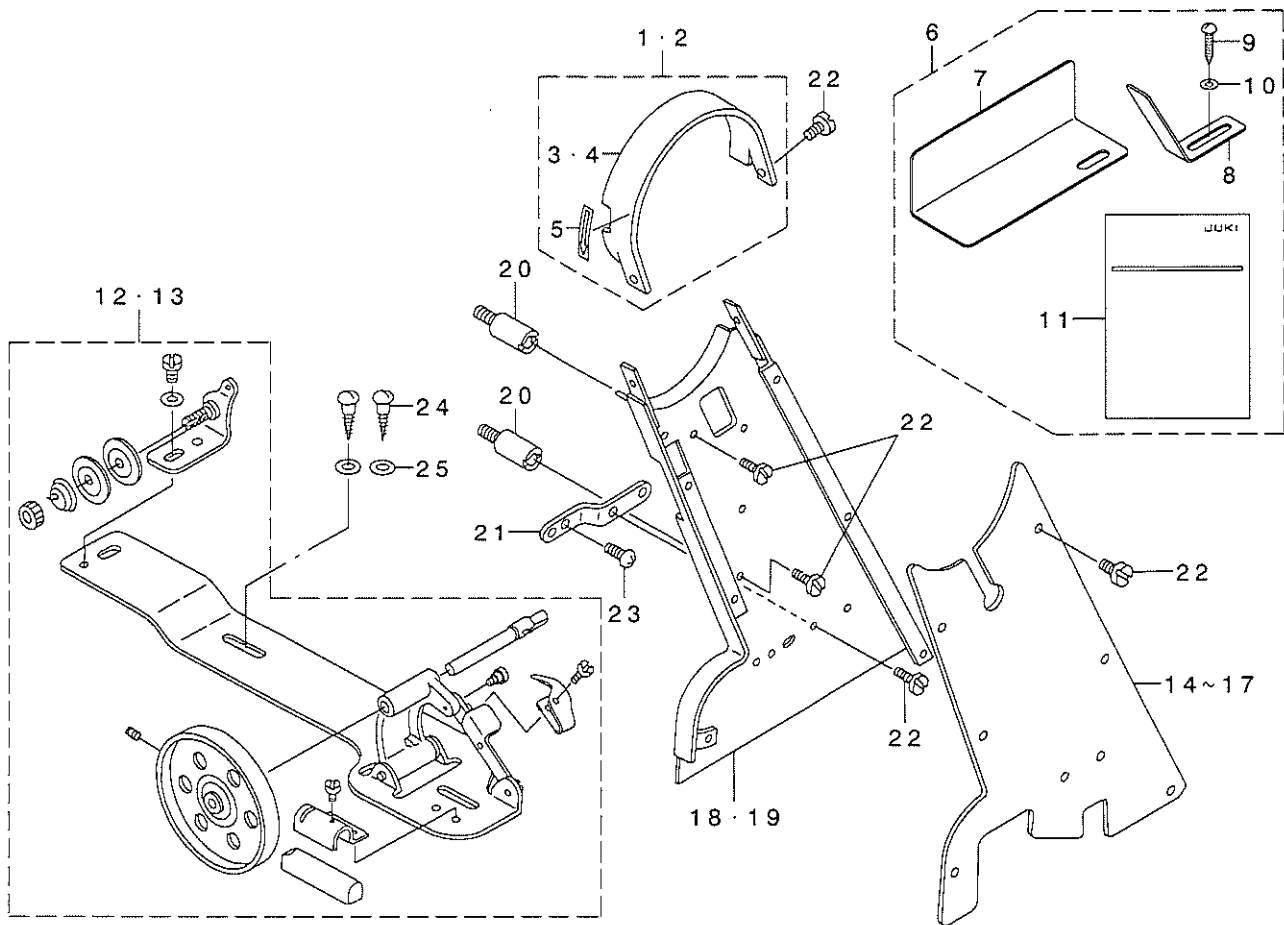

REF. NO	NOTE	PART NO.	DESCRIPTION	ヒョウメイ	Qty
1		B9101-245-OAO	TOP COVER(WITH LABEL)	トップカバー-(ラベル付き)	1
2	≠02	B9101-245-OAA	BELT COVER(WITH LABEL)	ベルトカバー-(ラベル付き)	1
3		B9101-245-000	TOP COVER	トップカバー-	(1)
4	≠02	B9101-245-00A	TOP COVER	トップカバー-	(1)
5		CM-5003000-01	DIRECTION LABEL	方向ラベル	(1)
6	≠03	B9112-245-OAA	BELT COVER ASM.	ベルトカバー-(クミ)	1
7		B9112-245-00A	SIDE COVER	サイドカバー-	(1)
8		B9113-245-00A	REAR COVER	リアカバー-	(1)
9		SK-3482500-SC	WOOD SCREW D=4.8 L=25	丸ネジ D=4.8 L=25	(1)
10		WP-0501016-SC	WASHER 5X10.5X1	ワッシャー 5X10.5X1	(1)
11		Z91-83803	BELT COVER INSTRUCTION MANUAL	DSC-245ベルトカバー-エイゼツ	(1)
12		B3201-012-OAO	BOBBIN WINDER ASM.	イトマキソーチ	1
13	≠02	B3201-245-OAO	THREAD WINDER	イトマキウチ(クミ)	1
14		B9104-245-OAO	BELT COVER ASM.	ベルトカバー-フタ(クツコウ)	1
15	≠01	B9104-246-000	BELT COVER, LOWER	ベルトカバー-(フタ)	1
16	≠02	B9104-245-OAA	BELT COVER ASM.	ベルトカバー-フタ(クツコウ)	1
17	≠04	B9104-246-00A	BELT COVER	ベルトカバー-フタ	1
18		B9102-245-OAO	BELT COVER ASM.	ベルトカバー-(クツコウ)	1
19	≠02	B9102-245-OAA	BELT COVER ASM.	ベルトカバー-(クツコウ)	1
20		B9106-245-000	BELT COVER SUPPORT BAR	ベルトカバー-シチユウ	2
21		E9108-245-000	BELT COVER SUPPORT	ベルトカバー-ササエタ	1
22		SS-6110480-SP	SCREW 11/64-40 L=4.3	ビス 11/64-40 L=4.3	12
23		SS-6111140-SP	SCREW 11/64-40 L=11	ビス 11/64-40 L=11	2
24		SK-3482500-SC	WOOD SCREW D=4.8 L=25	丸ネジ D=4.8 L=25	2
25		WP-0501016-SD	WASHER 5X10.5X1	ワッシャー 5X10.5X1	2

NOTE (注記)
 ≠01...OPTIONAL PARTS FOR DSC-244 DSC-244用オプション部品
 ≠02...FOR URBAN WHITE アーバンホワイト用
 ≠03...FOR DSC-244-4(URBAN WHITE)(JE), DSC-244-4(アーバンホワイト)(JE),
 -7(JE)用
 ≠04...OPTIONAL PARTS FOR DSC-244(URBAN WHITE) DSC-244(アーバンホワイト)用オプション部品

12. THREAD STAND COMPONENTS(For DSC-244)

糸立て関係 (DSC-244用)

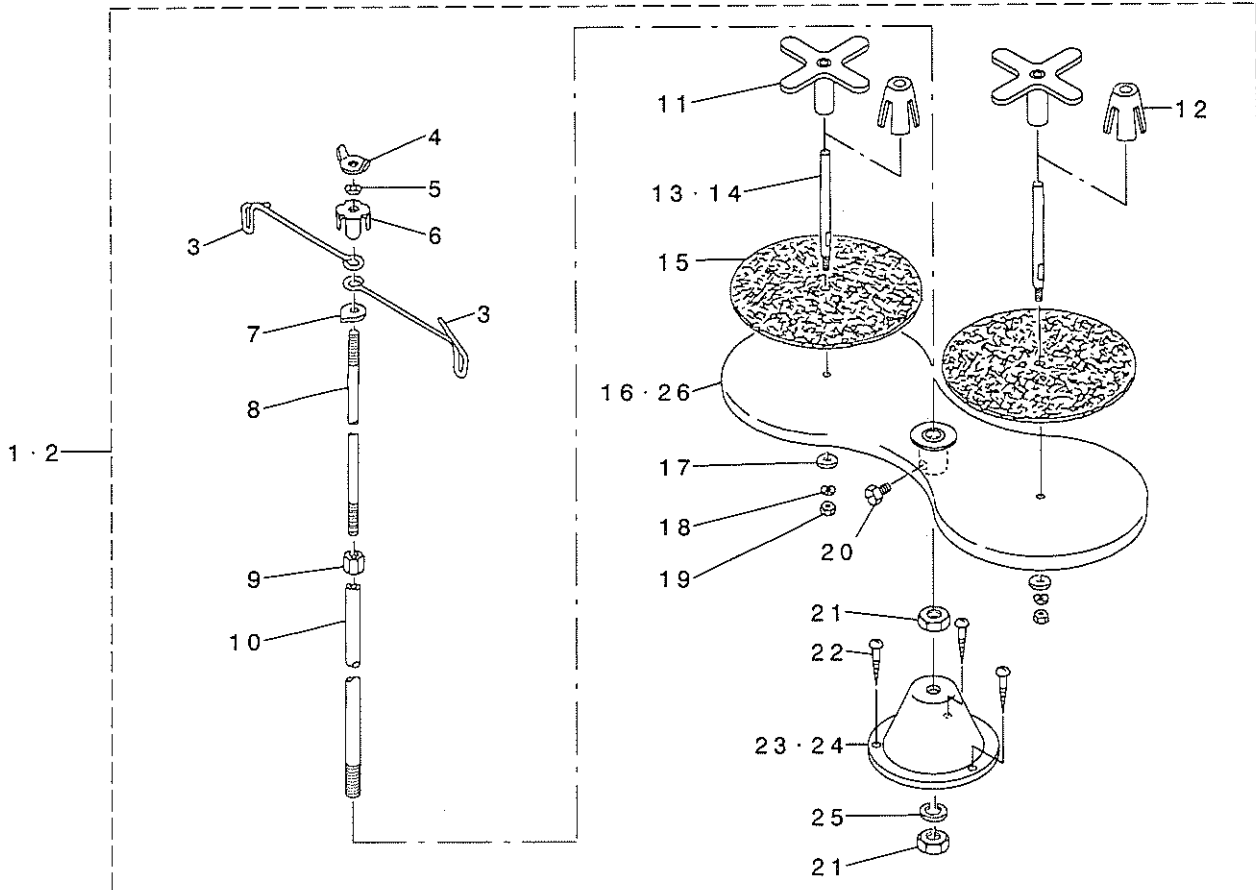

REF. NO	NOTE	PART NO.	DESCRIPTION	ヒョウメイ	Qty
1		B3301-012-0A0	THREAD STAND ASM.	イトダテ ソーチ クミ	1
2	#01	111-83159	THREAD STAND ASM.	イトダテソウチ(クミ)	1
3		B3307-012-000	THREAD GUIDE	イトダテ イトアンナイ	(1)
4		B3310-012-000	POSITION CUP SET SCREW	イトダテ イトアンナイ シメネジ	(1)
5		WS-0641560-KR	SPRING WASHER 6.4X11.9X1.5	ハネサガネ 6.4X11.9X1.5	(1)
6		B3309-012-000	POSITION CUP	イトダテ イトアンナイ マリトメ	(1)
7		B3308-012-000	ROD WASHER	イトダテ イトアンナイウケ	(1)
8		B3306-012-000	SPOOL ROD	イトダテ ウエカン	(1)
9		NM-6061061-SE	NUT M6	ロツカクナツト M6	(1)
10		B3302-012-000	SPOOL REST ROD	イトダテ シタカン	(1)
11		B3312-012-000	SPOOL RETAINER	イトマキ フルトメ	(2)
12	#01	111-84009	SPOOL RETAINER	イトマキ フルトメ	(2)
13		B3305-012-000	SPOOL PIN	イトマキ ウケホ	(2)
14	#01	B3320-704-L00-A	SPOOL PIN	イトマキウケホ ウ	(2)
15		B3311-012-000	SPOOL REST CUSHION	イトマキウケサ	(2)
16	#01	111-83209	SPOOL REST	イトマキウケ	(1)
17		WP-0560860-SE	WASHER 5.6X12X0.8	ヒラサガネ 5.6X12X0.8	(2)
18		WS-0531060-KR	SPRING WASHER 5.3X8.3X1	ハネサガネ 5.3X8.3X1	(2)
19		NS-6123881-SE	NUT 3/16-28	ロツカクナツト 3/16-28	(2)
20		SM-9061080-SE	SCREW M6 L=10	ロツカクホルト M6 L=10	(1)
21		NM-6100663-SE	NUT M10	ロツカクナツト M10	(2)
22		SK-3452000-SE	WOOD SCREW D=4.5 L=20	マルモクネジ D=4.5 L=20	(3)
23		B3301-012-000	SPOOL STAND	イトダテダイ	(1)
24	#01	111-83100	THREAD STAND	イトダテダイ	(1)
25		WS-1002560-KR	SPRING WASHER 10X18X2.5	ハネサガネ 10X18X2.5	(1)
26		B3303-012-000	SPOOL REST	イトマキウケ	(1)

NOTE (注記)

#01...FOR URBAN WHITE

ア-ハンホワイト用

13. THREAD STAND COMPONENTS(For DSC-244-4,-6,-7)

糸立て関係 (DSC-244-4, -6, -7用)

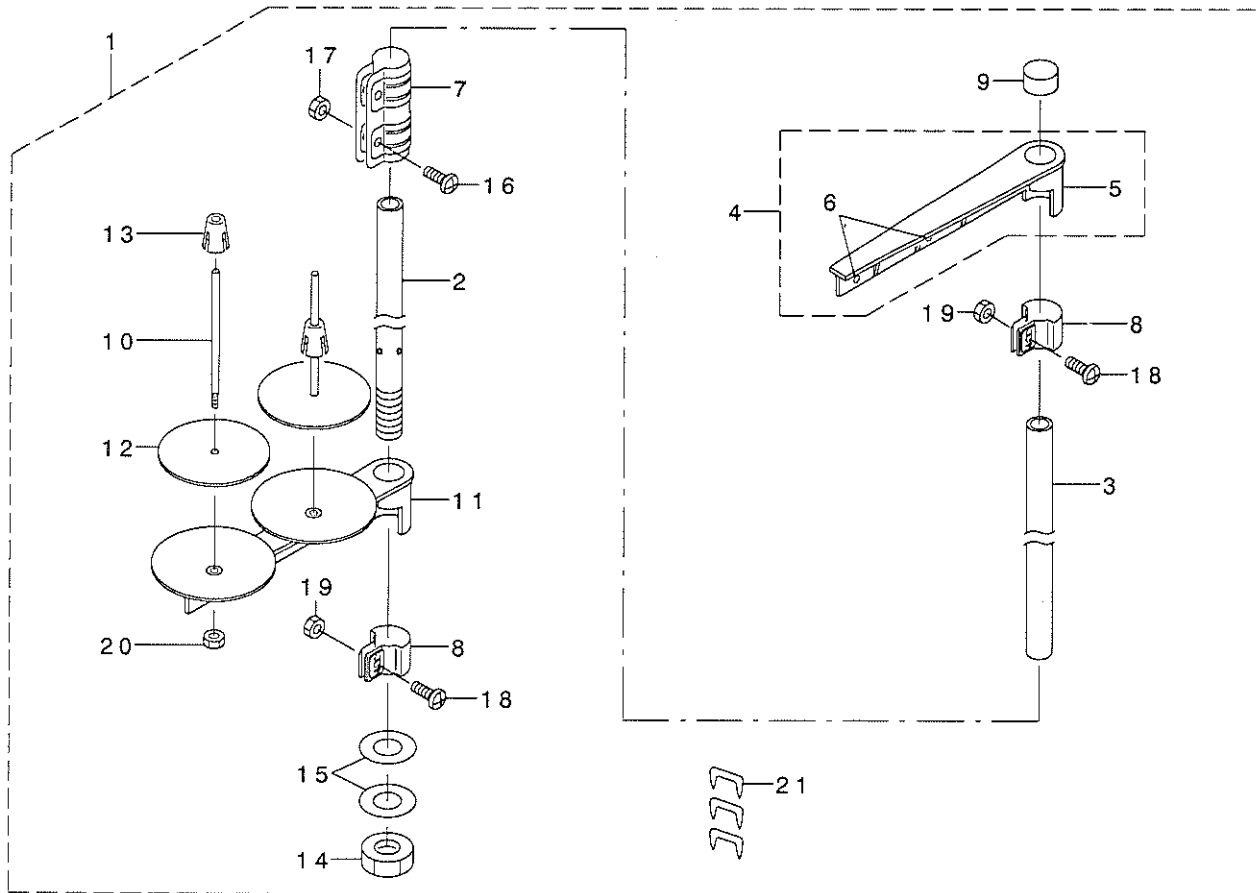

REF. NO	NOTE	PART NO.	DESCRIPTION	とよみ	Qty
1		111-85055	THREAD STAND ASM.	糸立てソウチクミ	1
2		111-85105	SPOOL REST ROD, LOWER	糸立てホウシタ	(1)
3		111-85204	SPOOL REST ROD, UPPER	糸立てホウウエ	(1)
4		111-85352	THREAD GUIDE ASM.	糸立てイトアソナイクミ	(1)
5		111-85303	THREAD GUIDE	糸立てイトアソナイ	(1)
6		B3319-704-L00	THREAD GUIDE	イトミチ	(2)
7		B3305-704-000-A	SPOOL REST ROD JOINT	糸立てホ-ツキテ	(1)
8		111-85402	THREAD GUIDE ARM JOINT	糸立てウテシメカナク	(2)
9		B3311-704-000	SPOOL REST ROD CAP	糸立てホ-キヤツブ	(1)
10		B3320-704-L00-A	SPOOL PIN	イトマキウホウ	(2)
11		111-85006	SPOOL REST ARM	イトタテウテ	(1)
12		B3311-012-000	SPOOL REST CUSHION	イトマキウケサ	(2)
13		111-85501	SPOOL RETAINER	イトマキフレトメ	(2)
14		B3317-704-000	NUT	糸立てホ-トメナツト	(1)
15		WP-1612616-SE	WASHER 16X30X2.6	ヒラサガネ	(2)
16		SM-4051405-SE	SCREW M5 L=14	ナハコネジ M5 L=14	(2)
17		NM-6050001-SE	NUT M5	ロツカクナツト M5	(2)
18		SM-4051405-SE	SCREW M5 L=14	ナハコネジ M5 L=14	(2)
19		NM-6050001-SE	NUT M5	ロツカクナツト M5	(2)
20		NM-6050001-SE	NUT M5	ロツカクナツト M5	(2)
21		MAO-11532000	CORD STAPLE	コードステツブ	(3)

14. TABLE COMPONENTS

脚卓関係

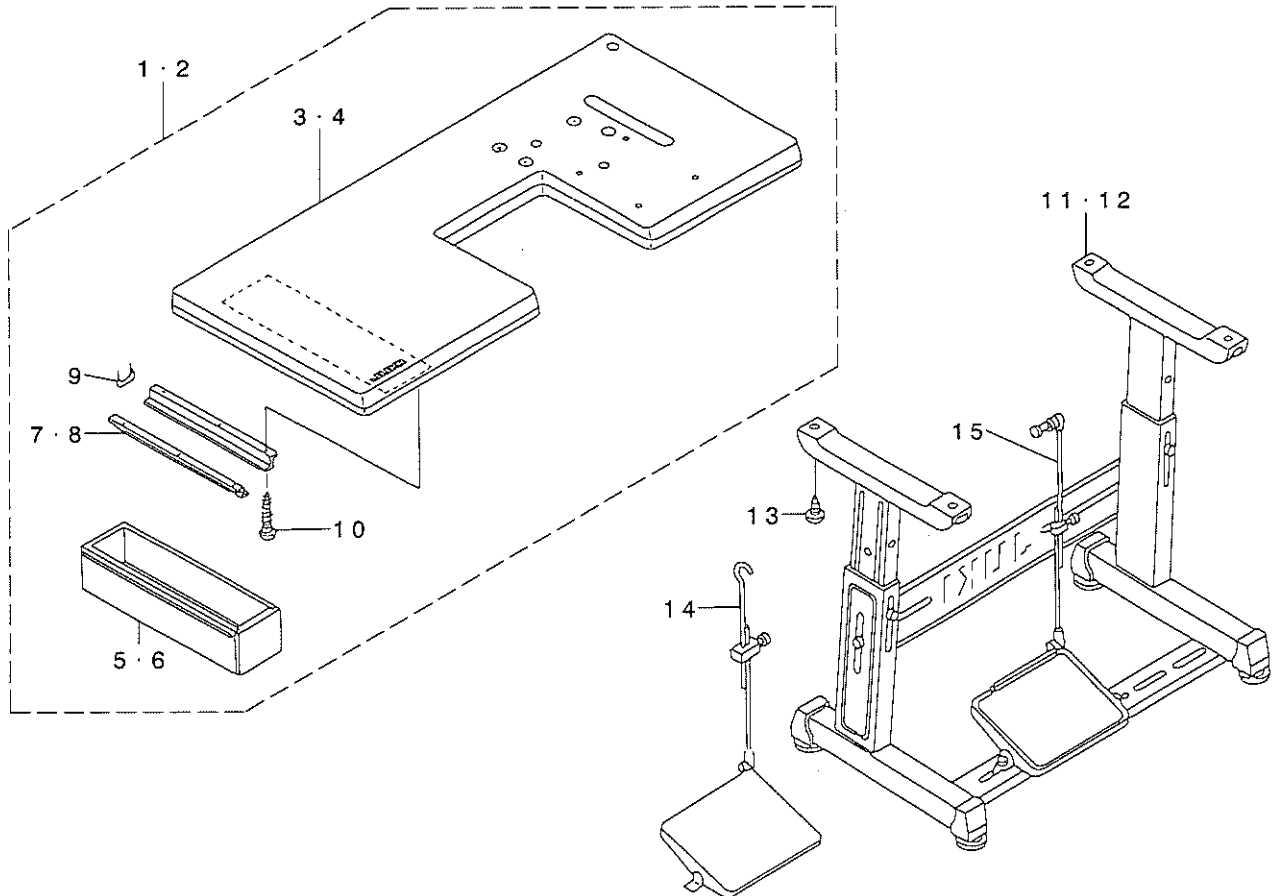

REF. NO	NOTE	PART NO.	DESCRIPTION	ヒシメイ	Qty
1	#01	D8201-245-EA0	TABLE ASM.	テーブル(クミ)	1
2	#05	D8201-245-GA0	TABLE ASM.	テーブル(クミ)	1
3	#01	D8201-245-E00	TABLE	テーブル	(1)
4	#05	D8201-245-G00	TABLE	テーブル	(1)
5	#01	118-49502	DRAWER	ヒキタシ	(1)
6	#05	111-55108	DRAWER	ヒキタシ	(1)
7	#01	B8204-012-000	DRAWER SUPPORT	ヒキタシ ササエ	(2)
8	#05	111-55207	DRAWER SUPPORT	ヒキタシ ササエ	(2)
9		D8204-555-D00	DRAWER STOPPER	ヒキタシ ストッパ	(1)
10		SK-3311600-SE	WOOD SCREW D=3.1 L=16	モクネジ D=3.1 L=16	(6)
11	#02	170-11263	T-LEG JUNCTION	Tキヤクツゴウ	1
12	#05	111-57567	T LEG JUNCTION	Tキヤクツゴウ	1
13		ST-9053511-SR	TAPPING SCREW M5X35	タツビソネジ	4
14	#03	B7114-012-0A0	MOTOR CONNECTING ROD ASM.	レンカツボ - ツキテクミ	1
15	#04	D7114-555-BAB	CONNECTING ROD ASM. (B)	レンカツボ - ルクミ	1
NOTE (注記)			#01... FOR DSC-244, -4-1B, -4-1, -6-0B, -6-00	DSC-244, -4-1B, -4-1, -6-0B, -6-00用	
			#02... FOR DSC-244, -6	DSC-244, -6用	
			#03... FOR DSC-244	DSC-244用	
			#04... FOR DSC-244-6, -7	DSC-244-6, -7用	
			#05... FOR URBAN WHITE	アパソホワイト用	

15. ACCESSORIES PARTS COMPONENTS

付属品関係

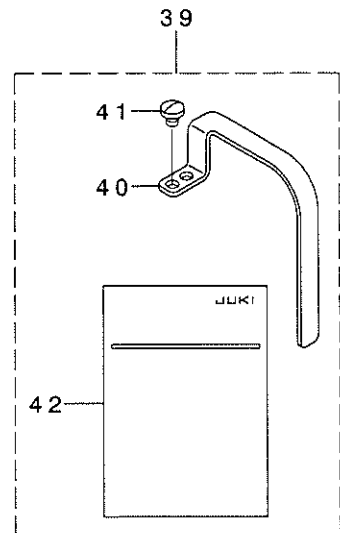
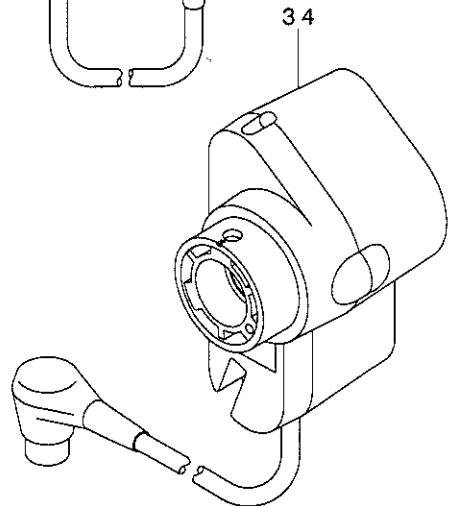
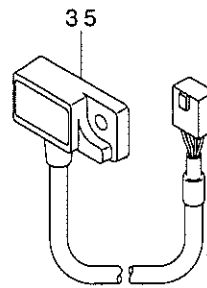
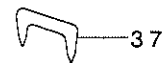
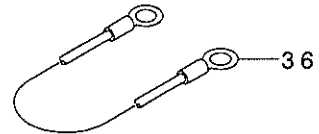
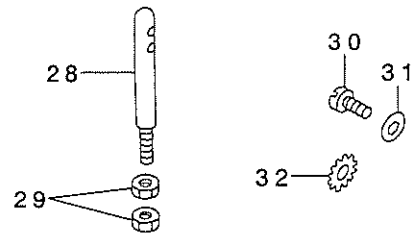
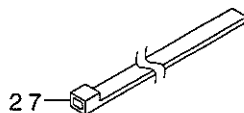
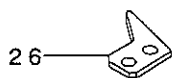
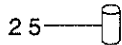
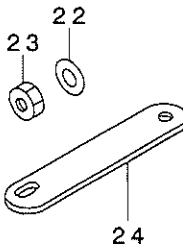
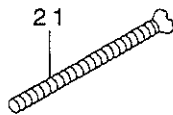
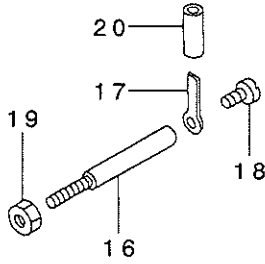
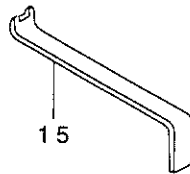
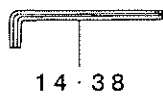
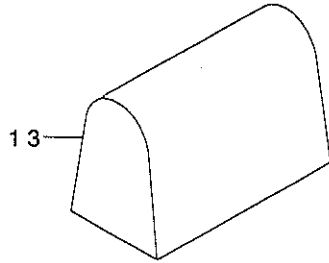
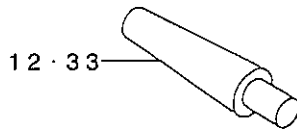
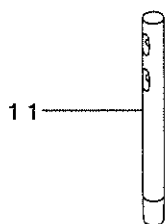
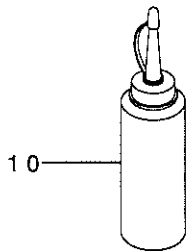
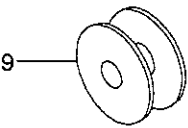
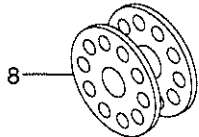
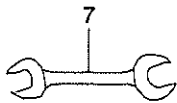
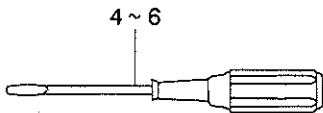
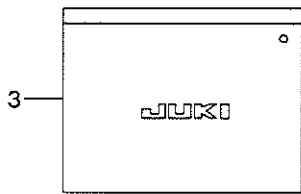
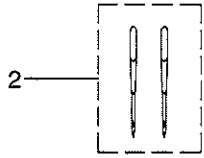
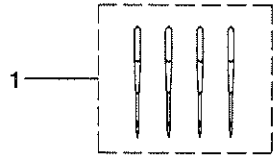

REF. NO	NOTE	PART NO.	DESCRIPTION	ヒョウメイ	Qty
1	#01	MDP-170B1804	NEEDLE DPX17 #18	ハリ DPX17 #18	1
2	#02	MC-3720011-02	NEEDLE SY3355 #110-2	SY3355 #110-2	1
3		B9101-552-000	ACCESSORY BOX	アソクヒンハコ	1
4		B9109-555-000	SCREW DRIVER, LARGE	トライハ - タイ	1
5		B9110-012-000	SCREW DRIVER, MIDDLE	トライハ - (チユウ)	1
6		B9111-012-000	SCREW DRIVER, SMALL	トライハ - (ショウ)	1
7		B9113-012-000	WRENCH (9X10)	リョウクチ スパナ (ショウ)	1
8	#03	B9117-012-000	BOBBIN	ホビン	3
9	#04	B9117-552-A00	BOBBIN	ホビン	3
10		B9121-220-0A0	OILER (CONTAINING NO.2 OIL)	アブラサシ NO2オイル	1
11		B1114-012-000	THREAD GUIDE PIN	イトアンナイホ -	1
12		B8204-245-000	FRAME SUPPORT BAR	トウブ ササエホウ	1
13		D9118-555-B00	PLASTIC COVER	トーフ ビニールカバー	1
14		J1066-000-00F	HEXAGONAL WRENCH KEY	ロツカクホ ウスパナ	1
15		B9111-245-000	WRENCH	オクリタ イアジメナツトスパナ	1
16	#04	D7101-245-E00	SYNCHRONIZER HOLDER STUD	ケンシユツキササエシク	1
17	#04	D7102-245-E00	SYNCHRONIZER HOLDER PLATE	ケンシユツキササエイタ	1
18	#04	SS-7110710-SP	SCREW 11/64-40 L=7	マルヒラネシ 11/64-40 L=7	1
19	#04	NS-6150430-SP	NUT 15/64-28	ロツカクナツト 15/64-28	1
20	#05	BT-0630520-Z0	HOLDER COVER	セツエン チュフ	1
21		B9130-245-000	BOLT	トリツケボルト	4
22		WP-0751576-SD	WASHER 7.5X19X1.5	ヒラサガネ 7.5X19X1.5	4
23		NM-6060001-SD	NUT M6	ロツカクナツト M6 1シユ	4
24		B9110-245-000	RUBBER PACKING	ゴムホ ツキン	2
25		B1632-245-00E	PIN	シヨウケ オクリビン	1
26	#04	D2402-245-E00	COUNTER KNIFE	コテイメス	1
27	#04	GES-12153000	OIL WICK HOLDER	ソクセンハント A	1
28	#06	B1114-517-000	NEEDLE THREAD GUIDE PIN	イトアンナイホ -	1
29	#06	NS-6620310-SP	NUT 3/16-32	ロツカクナツト 3/16-32	2
30	#06	SS-7110910-SP	SCREW 11/64-40 L=8.5	マルヒラネシ 11/64-40 L=8.5	2
31	#06	WP-0501016-SD	WASHER 5X10.5X1	ヒラサガネ 5X10.5X1	2
32	#06	WT-0530002-KS	TOOTHED WASHER D=5.3	ハツキサガネ D=5.3	2
33	#07	B8204-245-00A	FRAME SUPPORT BAR	トウブ ササエホウ	1
34	#08	GSY-01000AA0	SYNCHRONIZER SY-1-D2	SY-1 カンセイヒン トクハ ツシムケチシヨ	1
35	#09	M6069-350-DAA	RESISTANCE PACK DA ASM.	テイコウハ ツク DAクミ	1
36	#10	107-41759	GROUND WIRE ASM.	グラント センクミ	1
37	#10	MAO-11532000	CORD STAPLE	コト ステツプル	2
38	#08	B9141-372-000	HEXAGONAL WRENCH, LARGE	ロツカクホ - スパナ (タイ)	1
39	#11	B1158-245-0AA	THREAD TAKE-UP LEVER COVER ASM	テンビンカバー - (クミ)	1
40	#11	B1158-245-00A	THREAD TAKE-UP LEVER COVER	テンビンカバー -	(1)
41	#11	SS-7150740-SP	SCREW 15/64-28 L=7	マルヒラネシ 15/64-28 L=7	(2)
42	#11	291-83902	INSTRUCTION MANUAL	DSC-245テンビンカバー - エイセツ	(1)

NOTE (注記)

#01 . . . FOR DSC-244, -4-1B, -4-1, -6-0B, -6-00, -7	DSC-244, -4-1B, -4-1, -6-0B, -6-00, -7用
#02 . . . FOR DSC-244-4-1B(JE), -4-1(JE)	DSC-244-4-1B(JE), -4-1(JE)用
#03 . . . FOR DSC-244	DSC-244用
#04 . . . FOR DSC-244-4, -6, -7	DSC-244-4, -6, -7用
#05 . . . FOR DSC-244-4, -7	DSC-244-4, -7用
#06 . . . FOR DSC-244-6-0B, -6-00 (ONLY USE TYPE 4A1)	DSC-244-6-0B, -6-00用 (4A1のとき使用)
#07 . . . FOR URBAN WHITE	アバンホワイト用
#08 . . . FOR DSC-244-7	DSC-244-7用
#09 . . . FOR DSC-244-7(EXCEPT JE)	DSC-244-7(JE向けは除く)用
#10 . . . FOR DSC-244-4	DSC-244-4用
#11 . . . FOR DSC-244-4(URBAN WHITE)(JE), -7(JE)	DSC-244-4(アバンホワイト)(JE), -7(JE)用

16. GAUGE COMPONENTS

ゲージ関係

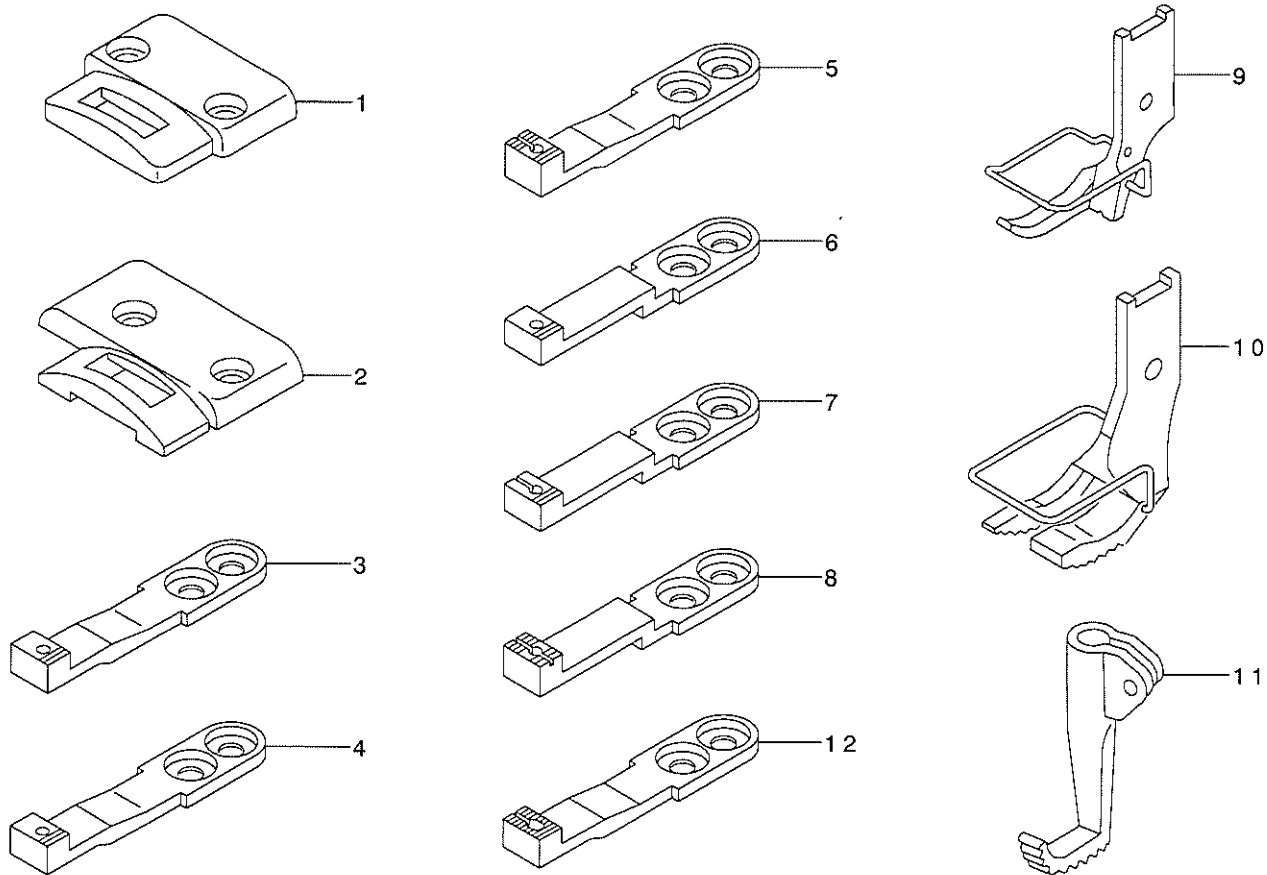

REF. NO	NOTE	PART NO.	DESCRIPTION	品名	Qty
1	#01	B1105-245-00C	THROAT PLATE	ハリイタ	1
2	#02	D1105-245-E0C	THROAT PLATE	ハリイタ	1
3	#01	B1613-245-00A	FEED DOG (FOR CLOTH)	オクリハ* (ヌノヨウ)	1
4	#01	B1613-245-00B	FEED DOG (FOR THIN NEEDLE)	オクリハ* (ホソハリヨウ)	1
5	#01	B1613-245-00C	FEED DOG	オクリハ*	1
6	#02	D1613-245-E0B	FEED DOG (FOR THIN NEEDLE)	オクリ(ホソハリヨウ)	1
7	#02	D1613-245-E00	FEED	オクリ	1
8	#02	D1613-245-E0C	FEED DOG	オクリハ*	1
9		B1524-245-0AA	PRESSER FOOT ASM.	オサエアシ クミ	1
10		B1524-245-0AB	PRESSER FOOT ASM.	オサエアシ(クミ)	1
11		B1470-245-00B	WALKING FOOT	ウワオクリアシ	1
12	#01	B1613-245-000	FEED DOG	オクリハ*	1
NOTE (注記)			#01... FOR DSC-244	DSC-244用	
			#02... FOR DSC-244-4, -6, -7	DSC-244-4, -6, -7用	

17. OPTION COMPONENTS(For DSC-244)

オプション関係 (DSC-244用)

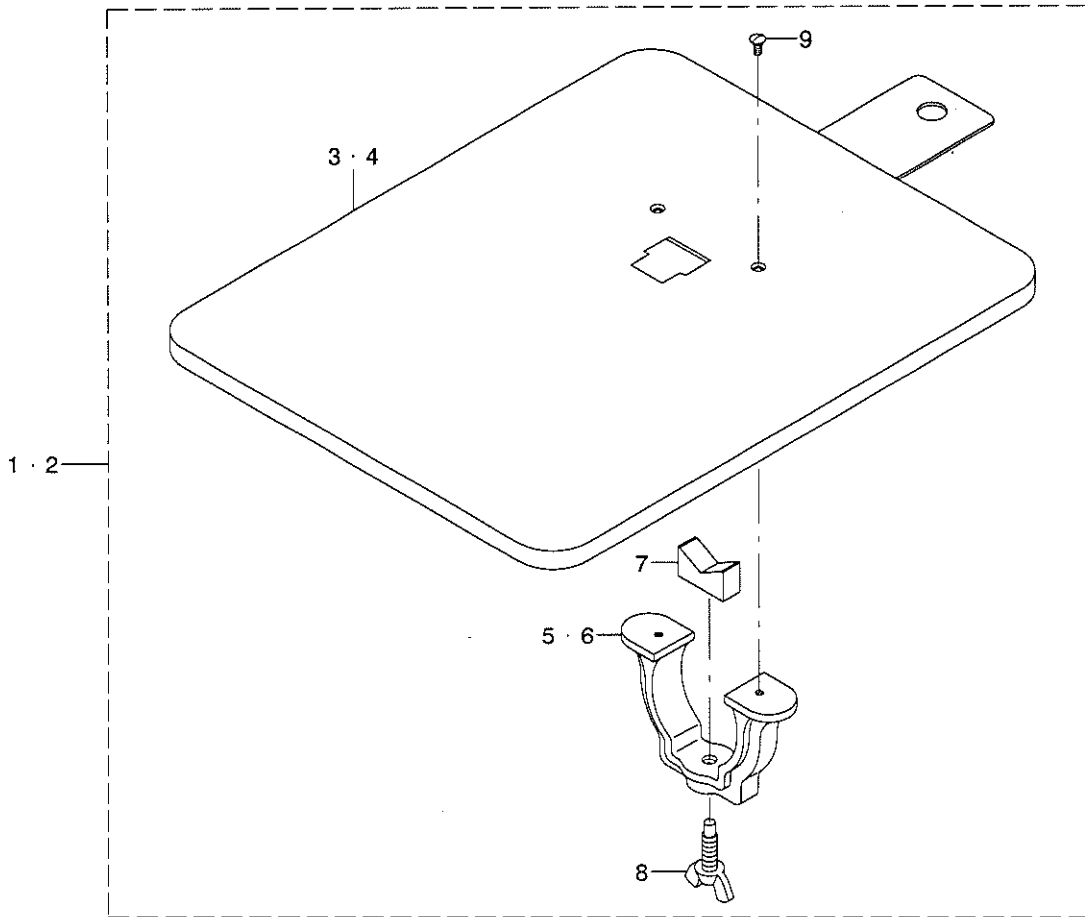

REF. NO	NOTE	PART NO.	DESCRIPTION	と ン メ イ	Qty
1		213-02757	PLAIN BED ASM.	ヒラハツト (クミ)	1
2	#01	213-08051	PLAIN BED ASM.	ヒラハツト (クミ)	1
3		213-02708	PLAIN BED	ヒラハツト	(1)
4	#01	213-08002	PLAIN BED	ヒラハツト	(1)
5		212-90200	STAND	トリツケダイ	(1)
6	#01	228-64409	STAND	トリツケダイ	(1)
7		212-90309	V-BLOCK	Vブロック	(1)
8		212-90408	SET SCREW	シメネジ	(1)
9		SS-2110920-TP	SCREW 11/64-40 L=8.5	マルサラネジ 11/64-40 L=8.5	(2)
	NOTE (注記)	#01	FOR DSC-244(URBAN WHITE)	DSC-244(ア・パ・ンホワイト)用	

NUMERICAL INDEX OF PARTS

索引

PART NO 品番	PAGE 頁	REF NO	PART NO 品番	PAGE 頁	REF NO	PART NO 品番	PAGE 頁	REF NO	PART NO 品番	PAGE 頁	REF NO
BP-3000000-00	10	38	B1455-053-000	12	3	B1806-038-000	12	52	B3425-245-000	18	2
BP-8000000-00	17	21	B1460-245-000	6	42	B1830-245-0A0	12	49	B3425-245-000-A	18	20
BT-0630520-Z0	24	20	B1460-246-0A0	6	55	B1837-245-0A0	12	57	B3431-552-000-A	18	23
B1105-245-00C	25	1	B1461-245-000	6	48	B1838-245-000	12	58	B3433-141-H0A	18	15
B1105-245-000	2	1	B1462-053-000	6	56	B1839-245-00A	12	53	B3434-141-H00	18	16
B1114-012-000	24	11	B1466-563-000	12	1	B1839-245-00B	12	54	B3502-115-000	17	3
B1114-280-000	10	7	B1467-053-0A0	12	9	B1839-245-00C	12	55	B3508-512-000	17	9
B1114-517-000	24	28	B1467-563-000	12	20	B1853-512-00A-A	14	35	B3517-009-000	2	25
B1116-246-000	2	11	B1468-053-000	12	10	B1853-512-00B-A	14	36	B6037-505-0A0	14	46
B1117-246-000	2	14	B1470-245-00B	25	11	B1853-512-00C-A	14	37	B7114-012-0A0	22	14
B1118-241-H0A	2	60	B1470-245-000	12	2	B1853-512-00D	14	38	B8133-019-000	18	30
B1118-241-H00	2	10	B1501-241-H00	6	36	B1853-512-00E	14	39	B8204-012-000	22	7
B1121-245-0AA	2	61	B1502-541-000	6	44	B1905-245-000	6	31	B8204-245-00A	24	33
B1121-245-0A0	2	8	B1509-141-H00	6	39	B1906-051-000	6	2	B8204-245-000	24	12
B1128-246-000	2	13	B1510-141-H00	6	38	B1906-051-000	6	32	B8217-241-H00	17	1
B1128-522-000	2	23	B1511-555-000	6	47	B2115-271-000	8	42	B8218-241-H00	17	2
B1129-563-000	2	26	B1512-141-H00	6	40	B2733-761-000	10	10	B9101-245-0AA	19	2
B1130-051-000	2	15	B1515-051-000	6	41	B3008-141-H00	12	5	B9101-245-0A0	19	1
B1130-521-0A0	2	17	B1524-245-0AA	25	9	B3031-141-H00	14	27	B9101-245-00A	19	4
B1130-521-000	2	18	B1524-245-0AB	25	10	B3031-141-H00	14	31	B9101-245-000	19	3
B1131-521-000	2	19	B1524-245-0A0	6	37	B3114-761-000	16	17	B9101-552-000	24	3
B1131-562-000	2	16	B1601-245-000	8	12	B3120-125-000	16	34	B9102-245-0AA	19	19
B1132-521-000	2	20	B1603-245-000	8	31	B3121-245-0A0	16	1	B9102-245-0A0	19	18
B1140-051-000	2	22	B1605-201-000	4	44	B3122-053-000	16	13	B9104-245-0AA	19	16
B1147-141-H00	8	22	B1605-245-000	8	24	B3123-051-000	16	5	B9104-245-0A0	19	14
B1148-141-H00	8	23	B1613-245-00A	25	3	B3124-051-000	16	6	B9104-246-00A	19	17
B1156-115-000	2	24	B1613-245-00B	25	4	B3125-012-000	16	2	B9104-246-000	19	15
B1158-245-0AA	24	39	B1613-245-00C	25	5	B3126-051-000	16	7	B9106-245-000	19	20
B1158-245-00A	24	40	B1613-245-00E	8	8	B3126-051-000	16	31	B9108-245-000	19	21
B1171-245-000	2	3	B1613-245-000	25	12	B3127-051-000	16	8	B9109-555-000	24	4
B1172-245-000	8	18	B1614-245-000	8	25	B3127-051-000	16	30	B9110-012-000	24	5
B1173-245-0A0	2	5	B1617-241-H00	8	36	B3128-051-000	16	9	B9110-245-000	24	24
B1174-245-000	2	6	B1618-241-H00	8	37	B3128-051-000	16	27	B9111-012-000	24	6
B1175-245-000	8	69	B1619-241-H00	8	26	B3129-053-000	16	3	B9111-245-000	24	15
B1180-245-000	2	47	B1620-245-000	8	27	B3129-053-000	16	33	B9112-245-0AA	19	6
B1180-245-000	2	53	B1621-241-H00	10	40	B3132-051-000	16	10	B9112-245-00A	19	7
B1183-245-00A	2	51	B1622-241-H00	8	28	B3132-051-000	16	32	B9113-012-000	24	7
B1183-245-00B	2	52	B1623-245-0A0	8	30	B3134-051-000	16	11	B9113-245-00A	19	8
B1202-241-H00	4	5	B1624-586-00A	10	53	B3137-051-0A0	16	12	B9117-012-000	12	50
B1203-051-000	4	9	B1624-586-000	10	42	B3137-527-0A0	16	28	B9117-012-000	24	8
B1203-241-H00	4	6	B1627-241-H00	10	50	B3138-512-000	16	44	B9117-552-A00	12	51
B1204-241-H00	4	7	B1630-245-0A0-A	8	2	B3201-012-0A0	19	12	B9117-552-A00	24	9
B1206-245-000	4	3	B1632-245-00A	8	3	B3201-245-0A0	19	13	B9121-220-0A0	24	10
B1208-019-000	6	59	B1632-245-00B	8	4	B3214-047-000	16	36	B9130-245-000	24	21
B1210-051-000	4	10	B1632-245-00C	8	5	B3301-012-0A0	20	1	B9141-372-000	24	38
B1211-141-H00	4	8	B1632-245-00D	8	6	B3301-012-000	20	23			
B1211-226-000	4	11	B1632-245-00E	8	7	B3302-012-000	20	10	CM-3002000-B2	2	65
B1212-012-000	4	12	B1632-245-00E	24	25	B3303-012-000	20	26	CM-3002000-02	2	66
B1213-012-000	4	13	B1633-245-000	8	11	B3305-012-000	20	13	CM-3002001-A1	2	64
B1213-012-000	12	12	B1634-245-000	8	41	B3305-704-000-A	21	7	CM-3002001-01	2	63
B1227-145-00A	4	1	B1635-245-000	8	14	B3306-012-000	20	8	CM-5003000-01	19	5
B1227-145-00B	4	49	B1636-245-00A	8	73	B3307-012-000	20	3	CQ-2020000-00	6	34
B1301-241-H00	4	33	B1636-245-000	8	43	B3308-012-000	20	7	CQ-2020000-00	17	11
B1302-241-H00	4	34	B1637-141-H00	8	44	B3309-012-000	20	6	CQ-2020000-00	17	12
B1303-271-000	4	35	B1637-245-000	8	16	B3310-012-000	20	4	CQ-2020000-00	17	13
B1305-012-0A0	4	37	B1638-141-H00	8	45	B3311-012-000	20	15	CQ-2020000-00	17	14
B1305-271-0B0	4	36	B1638-245-000	8	17	B3311-012-000	21	12	CQ-2020000-00	17	15
B1306-155-0C0	4	38	B1639-245-000	8	39	B3311-704-000	21	9	CQ-2020000-00	17	16
B1307-155-0A0	4	39	B1640-245-000	8	19	B3312-012-000	20	11	CQ-2020000-00	17	17
B1308-155-0A0	4	40	B1641-245-000	8	20	B3317-704-000	21	14	CQ-2520000-00	4	20
B1410-771-000	6	8	B1642-245-000	8	21	B3319-704-L00	21	6	CQ-2520000-00	4	21
B1414-232-000	6	7	B1643-145-000	8	32	B3320-704-L00-A	20	14	CQ-2520000-00	4	22
B1414-555-000	12	19	B1644-245-000	8	33	B3320-704-L00-A	21	10	CQ-2520000-00	6	60
B1419-245-000	6	3	B1645-245-000	8	34	B3414-245-000	18	4	CQ-2520000-00	17	20
B1420-563-000	6	1	B1646-241-H00	10	47	B3416-141-H00-A	18	3	CQ-3030000-00	4	19
B1423-245-000	6	17	B1646-245-000	8	35	B3418-245-000	18	5	CQ-3030000-00	12	26
B1424-158-000	6	6	B1647-245-000	8	38	B3420-245-0A0	18	11	CQ-3030000-00	12	32
B1424-158-000	6	19	B1648-122-000	10	48	B3420-245-000	18	12	CQ-5050000-00	4	18
B1424-158-000	8	40	B1650-245-00A	8	72	B3421-245-0A0	18	28	CS-127101A-SH	4	15
B1428-563-000	6	9	B1650-245-000	8	29	B3421-245-000	16	4	CS-1271012-SH	4	16
B1429-241-H00	6	14	B1651-245-000	8	54	B3421-245-000	18	29			
B1430-245-000	6	18	B1652-245-000	8	56	B3422-245-000	18	13	D1105-245-E0C	25	2
B1431-241-H00	6	4	B1653-245-000	8	57	B3423-245-000	18	14	D1105-245-E00	2	2
B1434-245-000	6	5	B1654-245-000	8	13	B3424-141-H00	18	17	D1150-241-E0A	2	59
B1437-051-000	17	8	B1655-245-000	8	15	B3424-245-000	18	19	D1150-241-E00	2	9
B1454-245-000	12	15	B1702-012-000	12	11	B3425-141-H00	18	18	D1158-241-E0A	2	67

NUMERICAL INDEX OF PARTS

索引

PART NO 品番	PAGE 頁	REF NO	PART NO 品番	PAGE 頁	REF NO	PART NO 品番	PAGE 頁	REF NO	PART NO 品番	PAGE 頁	REF NO
D1158-241-E00	2	7	D2420-245-E00	14	17	NM-6100663-SE	20	21	SS-6151220-SP	8	63
D1171-245-E00	2	4	D2421-245-E00	14	18	NS-6060350-SP	16	18	SS-6151220-SP	12	66
D1172-245-E00	8	71	D2423-245-E00	14	28	NS-6110310-SP	16	40	SS-7060310-SP	14	68
D1173-245-E00	2	45	D2423-245-E00	14	32	NS-6110350-SP	16	43	SS-7080510-TP	6	24
D1201-241-E00	4	4	D2424-245-E00	14	19	NS-6110530-SP	12	34	SS-7080510-TP	17	22
D1227-245-E0A	4	2	D2425-245-E00	14	20	NS-6123881-SE	20	19	SS-7080520-SP	8	68
D1227-245-G00	4	48	D2426-245-E00	14	21	NS-6150430-SP	10	22	SS-7090520-SP	16	45
D1230-552-B00	4	46	D2427-245-E00	14	22	NS-6150430-SP	24	19	SS-7090710-SP	10	49
D1401-245-E00	6	10	D2428-141-E00	14	44	NS-6620310-SP	18	8	SS-7090910-SP	6	25
D1408-241-E00	6	11	D2428-245-E00	14	23	NS-6620310-SP	24	29	SS-7091410-SP	14	63
D1411-241-E00	6	13	D2429-245-E00	14	24	NS-6660430-SP	12	35	SS-7110510-SP	12	39
D1412-241-E00	6	12	D2430-245-EA0	14	43	NS-6680320-SP	8	51	SS-7110540-SP	14	59
D1450-055-B00	12	13	D2431-245-E00	14	40	NS-6680410-SP	8	52	SS-7110570-SP	16	42
D1453-241-E00	12	14	D2432-245-E0A	14	88				SS-7110710-SP	2	32
D1455-055-B00	12	16	D2432-245-E00	14	34	PS-0200122-KO	16	14	SS-7110710-SP	2	40
D1456-055-B00	12	17	D2433-245-E00	14	72	PS-0400182-KO	8	46	SS-7110710-SP	2	42
D1458-241-E00	12	6	D2434-245-E00	14	66	PS-0600241-00	18	31	SS-7110710-SP	10	24
D1459-241-E00	12	7	D2435-245-E00	14	81	PS-0600502-KP	6	58	SS-7110710-SP	10	29
D1462-241-E00	6	43	D2436-141-E00	14	42	PT-0301600-S0	6	20	SS-7110710-SP	10	30
D1463-241-E00	6	46	D2436-245-E00	14	76				SS-7110710-SP	12	42
D1464-241-E0A	6	45	D2441-141-E00	14	74	RE-0300000-KO	8	49	SS-7110710-SP	12	43
D1480-241-EAA	12	22	D2464-555-B00	10	17	RE-0400000-KO	10	36	SS-7110710-SP	14	47
D1480-241-EA0	12	21	D3168-555-H0B	16	37	RE-0600000-KO	10	37	SS-7110710-SP	14	69
D1480-241-E0A	12	24	D3410-241-E00	18	1	RE-0700000-KO	6	21	SS-7110710-SP	14	75
D1480-241-E00	12	23	D3501-241-E00	17	4	RE-0700000-KO	6	27	SS-7110710-SP	16	19
D1481-241-E00	12	25	D3502-241-E0A	17	26	RE-0700000-KO	8	50	SS-7110710-SP	16	46
D1482-241-EAA	12	28	D3502-241-E00	17	5	RO-0611801-00	2	58	SS-7110710-SP	17	25
D1482-241-EA0	12	27	D3503-241-E00	17	6	RO-0742401-00	8	48	SS-7110710-SP	24	18
D1482-241-E0A	12	30	D3504-241-E00	17	7				SS-7110730-SP	18	10
D1482-241-E00	12	29	D3505-241-E00	6	61	SD-0380551-SL	2	21	SS-7110910-SP	12	40
D1483-241-E00	12	31	D3505-241-E00	17	19	SD-0470281-SP	16	15	SS-7110910-SP	14	60
D1484-241-E00	12	33	D6037-245-GA0	14	92	SD-0470281-SP	16	39	SS-7110910-SP	14	61
D1485-241-E00	12	64	D6043-555-B00	14	52	SD-0640231-SP	8	47	SS-7110910-SP	24	30
D1486-241-E00	12	65	D6043-555-B00	14	53	SD-0640321-SP	14	73	SS-7110910-TP	6	28
D1606-245-E00	8	10	D7101-245-E00	24	16	SD-0720331-SP	10	23	SS-7111120-SP	4	47
D1613-245-E0A	8	9	D7102-245-E00	24	17	SD-0790351-SP	18	7	SS-7111120-SP	12	41
D1613-245-E0B	25	6	D7114-555-BAB	22	15	SD-0790361-SP	18	6	SS-7111120-SP	17	24
D1613-245-E0C	25	8	D8201-245-EA0	22	1	SD-0800352-SP	2	29	SS-7111260-SP	6	53
D1613-245-E00	25	7	D8201-245-E00	22	3	SD-0800481-SP	6	49	SS-7111410-TP	14	62
D1621-241-E00	10	39	D8201-245-GA0	22	2	SK-1483200-SE	18	22	SS-7111810-SP	17	23
D1624-241-E0A	10	54	D8201-245-G00	22	4	SK-3311600-SE	22	10	SS-7121410-SP	10	26
D1624-241-E00	10	41	D8204-555-D00	22	9	SK-3452000-SE	20	22	SS-7150740-SP	6	50
D1630-245-EA0-A	8	1	D9118-555-B00	24	13	SK-3482500-SC	19	9	SS-7150740-SP	24	41
D1680-141-E00	10	6				SK-3482500-SC	19	24	SS-7150940-SP	2	43
D1681-241-E0A	10	55	EA-9500B01-00	17	18	SM-4051405-SE	21	16	SS-7151210-SP	6	23
D1681-241-E00	10	1	EA-9570B02-00	10	2	SM-4051405-SE	21	18	SS-7151210-SP	8	62
D1684-141-E00-A	10	16				SM-6031202-TP	4	41	SS-7151210-SP	10	25
D1685-141-E00	10	19	GES-12153000	14	33	SM-6081552-TP	2	33	SS-7151210-SP	10	28
D1686-241-E00	10	18	GES-12153000	24	27	SM-9061080-SE	20	20	SS-7151330-SP	8	64
D1687-141-E00	10	20	GES-12155000	10	21	SS-2090710-SP	2	34	SS-7620750-SP	10	43
D1841-141-E00	14	41	GSY-01000AA0	24	34	SS-2090710-SP	2	35	SS-7621040-SP	6	51
D1907-241-E00	6	33				SS-2090710-SP	2	39	SS-7621040-SP	6	52
D2120-555-C00	14	45	HK-0346101-40	14	89	SS-2090710-SP	2	41	SS-7680870-SP	2	57
D2401-245-E00	14	1	HK-0346400-0B	14	90	SS-2090710-SP	2	46	SS-7681750-TP	4	24
D2402-245-E00	14	2	HK-0346400-0B	14	91	SS-2090710-SP	16	20	SS-8090410-SP	14	67
D2402-245-E00	24	26	HW-5001400-00	10	3	SS-2090810-SP	8	67	SS-8110410-SP	8	65
D2403-245-E00	14	3	HW-5001400-00	10	4	SS-2110915-SP	2	37	SS-8110510-SP	2	44
D2404-245-E00	14	4				SS-2110920-TP	26	9	SS-8150710-SP	4	29
D2405-245-E00	12	59	J1066-000-00F	24	14	SS-3090520-SP	2	38	SS-8150710-SP	4	31
D2405-245-E00	14	5				SS-3090610-SP	2	36	SS-8150710-SP	10	52
D2406-245-E0A	14	6	MAO-11532000	21	21	SS-3090710-TP	16	41	SS-8150710-TP	6	29
D2409-245-E00	14	8	MAO-11532000	24	37	SS-4080610-SP	16	16	SS-8150710-TP	8	58
D2410-245-E00	14	9	MAT-81126T00	10	5	SS-5060310-SP	14	71	SS-8150830-SP	6	30
D2411-245-E00	14	10	MC-3720011-00	6	16	SS-5110710-SP	8	60	SS-8150830-SP	8	59
D2412-245-E00	14	11	MC-3720011-02	24	2	SS-6060210-SP	8	55	SS-8151150-SP	6	26
D2413-245-E00	14	12	MDP-170B1800	6	15	SS-6081210-SP	8	53	SS-8151150-SP	6	35
D2414-141-E00	2	12	MDP-170B1804	24	1	SS-6090610-SP	8	70	SS-8151230-SP	14	55
D2414-245-E0A	14	87	M6069-350-DAA	24	35	SS-6090810-SP	14	65	SS-8151230-SP	14	56
D2414-245-E00	14	13	M9637-110-000	14	51	SS-6090910-SP	6	54	SS-8151230-SP	14	57
D2415-245-EA0	14	25	M9640-110-000	14	50	SS-6092120-SP	2	27	SS-8151230-SP	14	58
D2415-245-E00	14	26				SS-6110480-SP	19	22	SS-8151550-SP	4	26
D2416-245-E00	14	14	NM-6050001-SE	21	17	SS-6110710-SP	12	36	SS-8151550-SP	4	28
D2417-245-EA0	14	29	NM-6050001-SE	21	19	SS-6111140-SP	16	47	SS-8151550-SP	4	30
D2417-245-E00	14	30	NM-6050001-SE	21	20	SS-6111140-SP	19	23	SS-8151550-SP	4	42
D2418-245-E00	14	15	NM-6060001-SD	24	23	SS-6121050-SP	8	61	SS-8151550-SP	12	56
D2419-245-E00	14	16	NM-6061061-SE	20	9	SS-6121210-SP	10	51	SS-8151780-SP	4	27

NUMERICAL INDEX OF PARTS

索引

PART NO 品番	PAGE 頁	REF NO	PART NO 品番	PAGE 頁	REF NO	PART NO 品番	PAGE 頁	REF NO	PART NO 品番	PAGE 頁	REF NO
SS-8660410-SP	14	80	110-23702	18	25						
SS-8660530-TP	12	60	110-23801	18	26						
SS-8660530-TP	14	54	110-24403	18	24						
SS-8660610-TP	4	17	110-71701	6	22						
SS-8660610-TP	12	38	110-72204	16	35						
SS-8660612-TP	14	64	110-72402	16	38						
SS-8660810-TP	10	45	111-55108	22	6						
SS-8661040-TP	10	44	111-55207	22	8						
SS-8680540-SP	4	32	111-57567	22	12						
SS-8680730-SP	4	43	111-83100	20	24						
SS-8681650-TP	4	25	111-83159	20	2						
SS-8701042-TP	8	66	111-83209	20	16						
SS-9091010-SP	14	70	111-84009	20	12						
SS-9111010-SP	10	27	111-85006	21	11						
SS-9151540-SR	18	27	111-85055	21	1						
SS-9161610-SP	12	37	111-85105	21	2						
SS-9182010-SN	18	21	111-85204	21	3						
ST-9053511-SR	22	13	111-85303	21	5						
			111-85352	21	4						
TA-0500000-RO	4	14	111-85402	21	8						
TA-0500601-MO	4	23	111-85501	21	13						
TA-0550604-RO	2	49	118-49502	22	5						
TA-0750404-RO	2	55	170-11263	22	11						
TA-0750704-RO	2	50									
TA-1050504-RO	2	30	211-36205	12	46						
TA-1120804-RO	2	48	211-36304	12	47						
TA-1250406-RO	2	28	211-36403	12	48						
TA-1550902-RO	2	54	211-36601	14	7						
TA-2050406-RO	2	56	211-36908	17	10						
TA-2100904-RO	2	31	212-09952	12	61						
			212-10059	12	62						
WP-0371026-SD	14	78	212-10901	12	63						
WP-0371026-SD	14	79	212-12600	14	82						
WP-0450000-SD	12	44	212-12709	14	83						
WP-0482086-SD	12	18	212-12808	14	84						
WP-0501016-SC	19	10	212-12907	14	85						
WP-0501016-SD	10	31	212-13004	14	86						
WP-0501016-SD	10	32	212-90200	26	5						
WP-0501016-SD	10	35	212-90309	26	7						
WP-0501016-SD	14	48	212-90408	26	8						
WP-0501016-SD	19	25	213-02104	12	45						
WP-0501016-SD	24	31	213-02203	4	45						
WP-0560860-SE	20	17	213-02708	26	3						
WP-0621016-SD	10	33	213-02757	26	1						
WP-0621016-SD	18	9	213-08002	26	4						
WP-0751576-SD	24	22	213-08051	26	2						
WP-1612616-SE	21	15	213-08101	4	50						
WS-0410002-KN	14	77	228-64409	26	6						
WS-0531060-KR	20	18	291-83803	19	11						
WS-0631510-KP	10	34	291-83902	24	42						
WS-0641560-KR	20	5									
WS-1002560-KR	20	25									
WT-0530002-KS	14	49									
WT-0530002-KS	24	32									
WZ-1052010-KP	10	46									
100-04109	2	62									
101-19105	10	13									
101-19204	10	12									
101-19303	10	14									
101-19402	10	15									
101-19709	10	11									
101-19907	10	8									
101-20004	10	9									
101-24204	16	26									
101-61305	10	56									
103-14003	12	4									
103-14508	12	8									
103-20059	16	22									
103-20075	16	21									
103-20109	16	23									
103-20208	16	29									
103-20505	16	24									
103-20703	16	25									
103-21107	6	57									
107-41759	24	36									

JUKI®

JUKI 株式会社

JUKI CORPORATION

お問い合わせ、ご相談は
To order or for further
information,
please contact:

※このパーツリストは商品改良のため予告なく変更する事があります。
*The description covered in this parts list is subject to change for improvement of the commodity without notice.
※このパーツリストは、1995年8月現在の商品仕様で編集したものです。
*This parts list is edited in accordance with the product specifications as of August 1995.