



550-12-33/34 [Инструкция по эксплуатации](#)

IMPORTANT
READ CAREFULLY BEFORE USE
KEEP FOR FUTURE REFERENCE

Все права защищены.

Собственность компании Dürkopp Adler GmbH и защищена авторским правом.

Любое повторное использование этих материалов, включая выдержки,

запрещено без предварительного письменного разрешения Dürkopp Adler GmbH.

Copyright © Dürkopp Adler GmbH 2022

1	Об этих инструкциях	5
1.1	Кому предназначены эти инструкции?.....	5
1.2	Условные обозначения: символы и знаки.....	6
1.3	Прочие документы.....	7
1.4	Ответственность	8
2	Безопасность.....	9
2.1	Основные правила безопасности.....	9
2.2	Сигнальные слова и символы.....	11
3	Описание машины.....	15
3.1	Компоненты машины	15
3.2	Правильная эксплуатация.....	16
3.3	Декларация соответствия	17
4	Эксплуатация	19
4.1	Подготовка машины к работе	19
4.2	Включение и выключение машины	20
4.3	Вставка/замена иглы	22
4.4	Заправка нитки в иглу	24
4.5	Заправка нити петлителя.....	27
4.6	Заправка усилительной ленты	31
4.6.1	Заправка усилительной ленты сверху	31
4.6.2	Заправка усилительной ленты снизу	34
4.7	Натяжение нити	37
4.7.1	Настройка количества игольной нити.....	38
4.7.2	Установка количества нити петлителя.....	40
4.7.3	Настройка первичного натяжения нити.....	43
4.8	Вкл./выкл. устройства натяжения усилительной ленты	45
4.9	Установка тормоза ленты.....	46
4.10	Фиксация лапок в верхней мертвой точке.....	48
4.11	Настройка расхода лапок.....	49
4.12	Настройка давления швейной лапки	50
4.13	Использование коленной кнопки во время шитья	51
4.14	Вкл. и выкл. максимального хода.....	53
4.15	Включение и выключение обрезки края.....	53
4.16	Включение и выключение лампы.....	54
4.17	Установка длины стежка	55
4.18	Шитье.....	56
5	Программирование Commander Pro	59
5.1	Панель управления Commander Pro	59
5.2	Работа с панелью управления Commander Pro.....	59
5.2.1	Символы и плитки	60

5.2.2	Ввод значений.....	62
5.2.3	Navigating the burger menu	62
5.2.4	Навигация при запуске панели управления.....	63
5.3	Управление пользователем.....	63
5.3.1	Вход пользователя в систему	65
5.3.2	Авторизация техника по умолчанию	68
5.4	Режимы работы ПО	76
5.5	Использование ручного режима	77
5.5.1	Настройка интерфейса пользователя.....	77
5.5.2	Настройка параметров.....	81
5.5.3	Настройка параметров поперечных швов	82
5.5.4	Настройка параметров начала шва	88
5.5.5	Настройка параметров сегментов.....	89
5.5.6	Настройка параметров конца шва.....	90
5.6	Автоматический режим	90
5.6.1	Шитье в автоматическом режиме.....	93
5.6.2	Отмена программы в автоматическом режиме	94
5.7	Режим программирования.....	94
5.7.1	Управление программами	96
5.7.2	Управление швами	96
5.7.3	Редактирование участков шва.....	97
5.7.4	Управление участками.....	98
5.7.5	Настройка параметров программ.....	99
5.7.6	Настройка параметров начала шва/участка.....	104
5.7.7	Настройка параметров участка.....	105
5.7.8	Настройка параметров конца участка/конца шва.....	107
5.8	Импорт/экспорт программ	108
5.9	Выполнение обновления ПО.....	109
6	Техническое обслуживание.....	111
6.1	Интервалы технического обслуживания	112
6.2	Чистка.....	113
6.3	Смазка.....	114
6.3.1	Checking the lubrication of the machine head	116
6.3.2	Checking the hook lubrication	117
6.4	Servicing the pneumatic system.....	120
6.4.1	Setting the operating pressure	120
6.4.2	Draining the water condensation	121
6.4.3	Cleaning the filter element.....	122
6.5	Parts list.....	123
7	Setup	125
7.1	Checking the scope of delivery	125
7.2	Removing the transport locks.....	125
7.3	Assembling the reel stand.....	126

7.4	Setting the working height	128
7.5	Setting the pedal	130
7.6	Inserting the machine head	132
7.7	Tilting and erecting the machine head	134
7.8	Electrical connection	136
7.9	Establishing equipotential bonding	136
7.10	Pneumatic connection	137
7.10.1	Assembling the compressed air maintenance unit	137
7.10.2	Setting the operating pressure	138
7.11	Lubricating	139
7.12	Performing a test run	141
8	Decommissioning	143
9	Disposal	145
10	Troubleshooting	147
10.1	Customer Service	147
10.2	Messages of the software	147
10.3	Errors in sewing process	171
11	Technical data	173
11.1	Data and characteristic values	173
11.2	Requirements for trouble-free operation	174
12	Appendix	175
12.1	Wiring diagram	175
12.2	Tabletop drawing	181

1 About these instructions



These instructions have been prepared with utmost care. They contain information and notes intended to ensure long-term and reliable operation.

Should you notice any discrepancies or if you have improvement requests, then we would be glad to receive your feedback through **Customer Service** ( p. 147).

Consider the instructions part of the product and store them in a place where they are readily available.

1.1 For whom are these instructions intended?

These instructions are intended for:

- **Operators:**
This group is familiar with the machine and has access to the instructions. Specifically, chapter **Operation** ( p. 19) is important for the operators.
- **Specialists:**
This group has the appropriate technical training for performing maintenance or repairing malfunctions. Specifically, the chapter **Setup** ( p. 125) is important for specialists.

Service Instructions are supplied separately.

With regard to minimum qualification and other requirements to be met by personnel, please also follow the chapter **Safety** ( p. 9).

1.2 Representation conventions – symbols and characters

Various information in these instructions is represented or highlighted by the following characters in order to facilitate easy and quick understanding:



Proper setting

Specifies proper setting.



Disturbances

Specifies the disturbances that can occur from an incorrect setting.



Cover

Specifies which covers must be disassembled in order to access the components to be set.



Steps to be performed when operating the machine (sewing and equipping)



Steps to be performed for service, maintenance, and installation



Steps to be performed via the software control panel

The individual steps are numbered:

1. First step
 2. Second step
 - ...
- The steps must always be followed in the specified order.
- Lists are marked by bullet points.



Result of performing an operation

Change to the machine or on the display/control panel.



Important

Special attention must be paid to this point when performing a step.



Information

Additional information, e.g. on alternative operating options.



Order

Specifies the work to be performed before or after a setting.

References



Reference to another section in these instructions.

Safety

Important warnings for the user of the machine are specifically marked. Since safety is of particular importance, hazard symbols, levels of danger and their signal words are described separately in the chapter **Safety** ( p. 9).

Location information

If no other clear location information is used in a figure, indications of **right** or **left** are always from the user's point of view.

1.3 Other documents

The machine includes components from other manufacturers. Each manufacturer has performed a hazard assessment for these purchased parts and confirmed their design compliance with applicable European and national regulations. The proper use of the built-in components is described in the corresponding manufacturer's instructions.

1.4 Liability

All information and notes in these instructions have been compiled in accordance with the latest technology and the applicable standards and regulations.

Dürkopp Adler cannot be held liable for any damage resulting from:

- Breakage and damage during transport
- Failure to observe these instructions
- Improper use
- Unauthorized modifications to the machine
- Use of untrained personnel
- Use of unapproved parts

Transport

Dürkopp Adler cannot be held liable for breakage and transport damages. Inspect the delivery immediately upon receiving it.

Report any damage to the last transport manager. This also applies if the packaging is not damaged.

Leave machines, equipment and packaging material in the condition in which they were found when the damage was discovered. This will ensure any claims against the transport company.

Report all other complaints to Dürkopp Adler immediately after receiving the product.

2 Safety

This chapter contains basic information for your safety. Read the instructions carefully before setting up or operating the machine. Make sure to follow the information included in the safety instructions. Failure to do so can result in serious injury and property damage.



2.1 Basic safety instructions

The machine may only be used as described in these instructions. The instructions should be available at the machine's location at all times.

Work on live components and equipment is prohibited. Exceptions are defined in the DIN VDE 0105.

For the following work, switch off the machine at the main switch or disconnect the power plug:

- Replacing the needle or other sewing tools
- Leaving the workstation
- Performing maintenance work and repairs
- Threading

Missing or faulty parts could impair safety and damage the machine. Only use original parts from the manufacturer.

Transport Use a lifting carriage or forklift to transport the machine. Raise the machine max. 20 mm and secure it to prevent it from slipping off.

Setup The connecting cable must have a power plug approved in the relevant country. The power plug may only be assembled to the power cable by qualified specialists.

Obligations of the operator Follow the country-specific safety and accident prevention regulations and the legal regulations concerning industrial safety and the protection of the environment.

All the warnings and safety signs on the machine must always be in legible condition. Do not remove!

Missing or damaged warnings and safety signs must be replaced immediately.

Requirements to be met by the personnel

Only qualified specialists may:

- Setting up the machine
- Performing maintenance work and repairs
- Performing work on electrical equipment

Only authorized persons may work on the machine and must first have understood these instructions.

Operation

Check the machine during operating for any externally visible damage. Stop working if you notice any changes to the machine. Report any changes to your supervisor. Do not use a damaged machine any further.

Safety equipment

Safety equipment should not be removed or deactivated. If it is essential to remove or deactivate safety equipment for a repair operation, it must be assembled and put back into operation immediately afterward.



2.2 Signal words and symbols used in warnings



Warnings in the text are distinguished by color bars. The color scheme is based on the severity of the danger. Signal words indicate the severity of the danger.

Signal words Signal words and the hazard they describe:

Signal word	Meaning
DANGER	(with hazard symbol) If ignored, fatal or serious injury will result
WARNING	(with hazard symbol) If ignored, fatal or serious injury can result
CAUTION	(with hazard symbol) If ignored, moderate or minor injury can result
CAUTION	(with hazard symbol) If ignored, environmental damage can result
NOTICE	(without hazard symbol) If ignored, property damage can result

Symbols The following symbols indicate the type of danger to personnel:

Symbol	Type of danger
	General
	Electric shock

Symbol	Type of danger
	Puncture
	Crushing
	Environmental damage

Examples Examples of the layout of warnings in the text:

DANGER



Type and source of danger!

Consequences of non-compliance.

Measures for avoiding the danger.

↪ This is what a warning looks like for a hazard that will result in serious injury or even death if ignored.

WARNING



Type and source of danger!

Consequences of non-compliance.

Measures for avoiding the danger.

↪ This is what a warning looks like for a hazard that could result in serious or even fatal injury if ignored.

CAUTION



Type and source of danger!

Consequences of non-compliance.

Measures for avoiding the danger.

- ↪ This is what a warning looks like for a hazard that could result in moderate or minor injury if the warning is ignored.

NOTICE

Type and source of danger!

Consequences of non-compliance.

Measures for avoiding the danger.

- ↪ This is what a warning looks like for a hazard that could result in property damage if ignored.

CAUTION



Type and source of danger!

Consequences of non-compliance.

Measures for avoiding the danger.

- ↪ This is what a warning looks like for a hazard that could result in environmental damage if ignored.

3 Machine description

3.1 Components of the machine

Fig. 1: Components of the machine

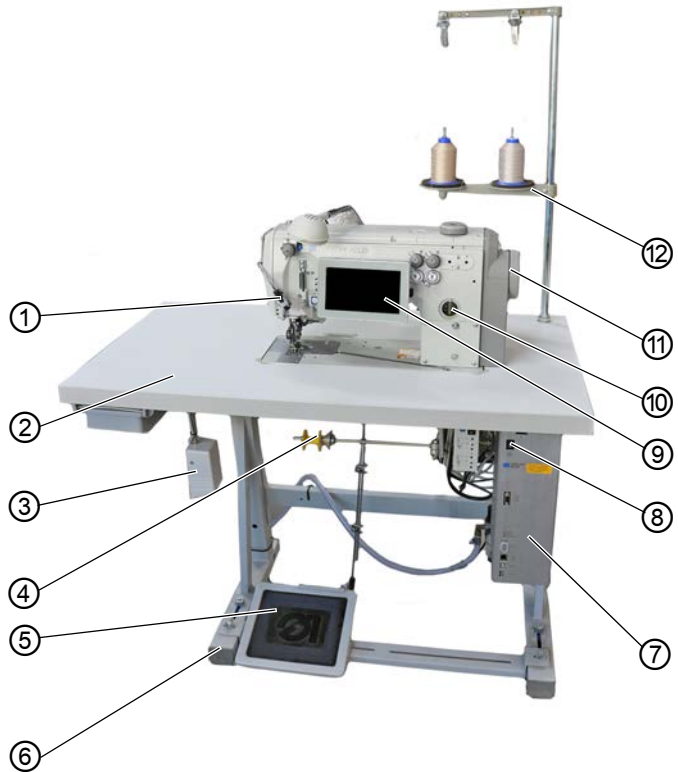

- (1) - External sewing lamp
- (2) - Tabletop
- (3) - Knee button
- (4) - Lower tape feeder
- (5) - Pedal
- (6) - Stand

- (7) - Control
- (8) - Main switch
- (9) - Control panel Commander Pro
- (10) - Oil-wick lubrication
- (11) - Handwheel
- (12) - Reel stand

3.2 Proper use

WARNING



Risk of injury from live, moving and cutting parts as well as from sharp parts!

Improper use can result in electric shock, crushing, cutting and punctures.

Follow all instructions provided.

NOTICE

Non-observance will lead to property damage!

Improper use can result in material damage at the machine.

Follow all instructions provided.

The machine may only be used with sewing material that satisfies the requirements of the specific application at hand.

The machine is intended only for use with dry sewing material. The sewing material must not contain any hard objects.

The needle thicknesses permissible for the machine are listed in the **Technical data** (📖 p. 173) chapter.

The seam must be completed with a thread that satisfies the requirements of the specific application at hand.

The machine is intended for industrial use.

The machine may only be set up and operated in dry conditions on well-maintained premises. If the machine is operated on premises that are not dry and well-maintained, then further measures may be required which must be compatible with DIN EN 60204-31.

Only authorized persons may work on the machine.

Dürkopp Adler cannot be held liable for damages resulting from improper use.

3.3 Declaration of Conformity

The machine complies with European regulations ensuring health, safety, and environmental protection as specified in the declaration of conformity or in the declaration of incorporation.



4 Operation

The operating sequence consists of several different steps. Fault-free operation is necessary in order to achieve a good sewing result.

4.1 Preparing the machine for operation

WARNING







Risk of injury from moving, cutting and sharp parts!

Crushing, cutting and punctures are possible.

If possible, make preparations only when the machine is switched off.

Complete the following steps in preparation of sewing before starting to work:

- Inserting/changing the needle ( p. 22)
- Threading the needle thread ( p. 24)
- Threading the hook thread ( p. 27).
- Setting the thread tension ( p. 37)
- Threading the reinforcement tape ( p. 31)

4.2 Switching on and off the machine

WARNING



Risk of injury from moving, cutting and sharp parts!

Crushing, cutting and punctures are possible.

Do not sew unless the machine is fully assembled and includes all safety devices.

NOTICE

Property damage may occur!

While the machine is referencing and while the needle is down, the needle or the hook tip may break.

Do not switch the machine off unless the needle is up and NOT plunged in the material.

Fig. 2: Switching on and off the machine

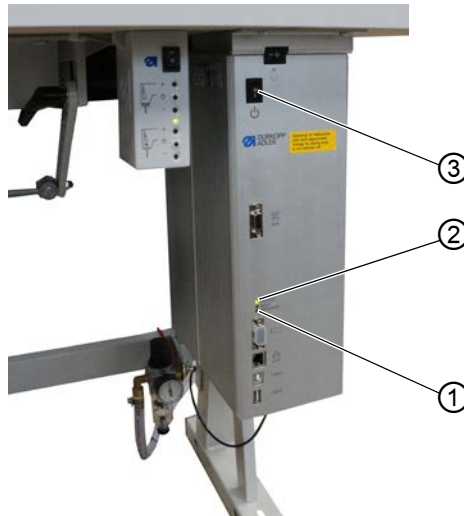

- (1) - MESSAGE LED
- (2) - POWER LED

- (3) - Main switch

Switching on the machine



To switch on the machine:

1. Ensure that the needle is up and not plunged in the material at the bottom.



Important

The needle must be at the top dead center, ensuring that needle and hook tip cannot become damaged during referencing.

2. Set the main switch (3) to position I.
 - ↪ POWER LED (2) illuminates, and the MESSAGE LED (1) flashes briefly.
 - ↪ The splash screen appears on the display:
 - On the left, the class
 - On the right, the firmware
 - ↪ The machine performs a reference run and is ready for sewing when the display shows the start screen.
The control remains in automatic mode only for a few seconds before switching to manual mode.

Switching off the machine



To switch off the machine:

1. Ensure that the needle is up and not plunged in the material at the bottom.



Important

The needle must be at the top dead center, ensuring that needle and hook tip cannot become damaged the next time the machine is switched on and completes a reference run.

2. Set the main switch (3) to position 0.
 - ↪ The control panel shuts down. When the POWER LED (2) goes out, the machine and the control are disconnected from the power supply.

4.3 Inserting/changing the needle

WARNING



Risk of injury from moving, cutting and sharp parts!

Crushing, cutting and punctures are possible.

Only insert or change the needle with the machine switched off.

NOTICE

Property damage may occur!

Risk of missing stitches or damage to the thread when using thinner needles. Risk of damage to the hook tip or the needle when using thicker needles.

Correct the settings when using needles with a different thickness.

Fig. 3: Inserting/changing the needle

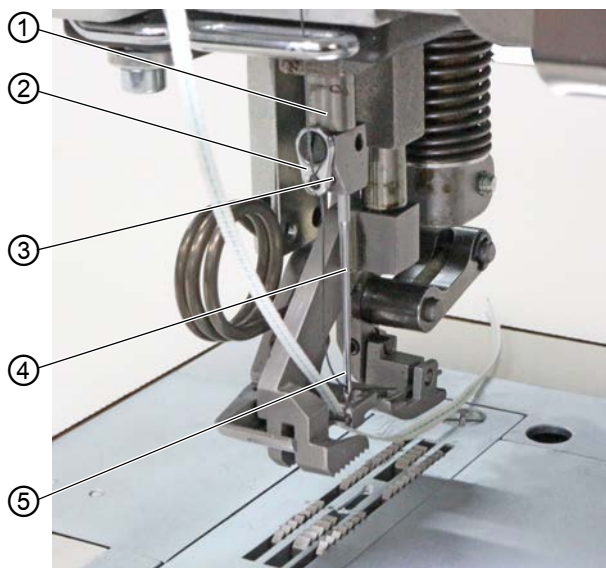

- (1) - Needle bar
- (2) - Thread guide
- (3) - Threaded pin

- (4) - Needle
- (5) - Groove



To change the needle:

1. Turn handwheel until the needle (4) is at the top dead center.
2. Loosen the threaded pin (3) through the hole in the thread guide (2).

This requires that the thread guide (2) be assembled completely straight to the needle bar (1).

3. Pull the needle (4) down and out.
4. Insert the new needle (4) into the hole in the needle bar (1) until it reaches the end stop.



Important

Align the needle (4) in such a way that the groove (5) is pointing to the rear.

5. Tighten the threaded pin (3) through the hole in the thread guide (2).



Order

Always adjust the clearance between the hook and the needle (4) after changing to a different needle thickness ( *Service Instructions*).



Disturbance

An incorrect hook distance can cause the following disturbances:

- Changing to a thinner needle:
 - Missing stitches
 - Thread damage
- Changing to a thicker needle:
 - Damage to the hook tip
 - Damage to the needle

4.4 Threading the needle thread

WARNING



Risk of injury from moving, cutting and sharp parts!

Crushing, cutting and punctures are possible.

Only thread the needle thread with the machine switched off.

Fig. 4: Threading the needle thread (1)

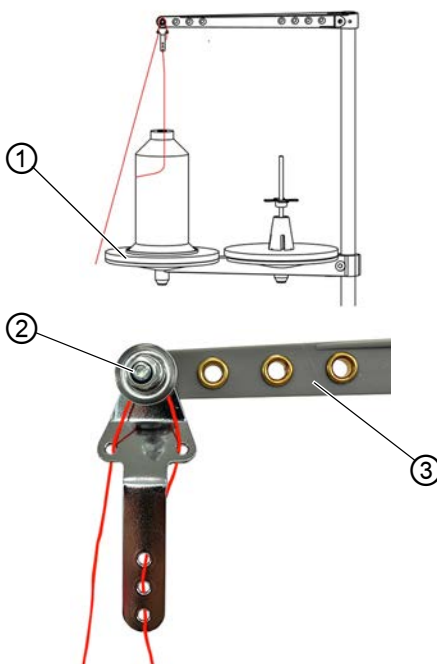

(1) - Left thread reel plate
(2) - Tensioner

(3) - Thread guide



To thread the needle thread:

1. Fit the thread reel on the left thread reel plate (1).
2. Feed the needle thread through the thread guides as shown and guide it around the tensioner (2).



Important

The unwinding bracket (3) must stand directly above the thread reels.

Fig. 5: Threading the needle thread (2)

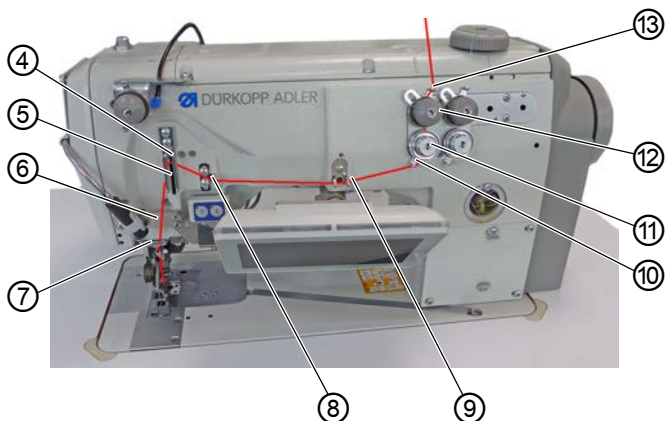

- | | |
|-------------------------------|---------------------|
| (4) - Thread lever | (9) - Thread guide |
| (5) - Needle thread regulator | (10) - Thread guide |
| (6) - Bracket | (11) - Tensioner |
| (7) - Thread guide | (12) - Tensioner |
| (8) - Thread guide | (13) - Thread guide |



3. Feed the needle thread from top to bottom through the thread guide (13).
4. Guide the needle thread counterclockwise around the tensioner (12).
5. Guide the needle thread clockwise around the tensioner (11).
6. Feed the needle thread, as shown, through thread guides (8), (9) and (10).
7. Feed the needle thread through the needle thread regulator (5) and the thread lever (4).



Important

When feeding the thread through the needle thread regulator (5) and the thread lever (4), pay attention as to how much needle thread is needed to ensure proper stitch formation. The required needle thread quantity defines the threading of the needle thread ( p. 38).

8. Feed the needle thread downwards behind the bracket (6).
9. Insert the needle thread through thread guide (7).

Fig. 6: Threading the needle thread (3)

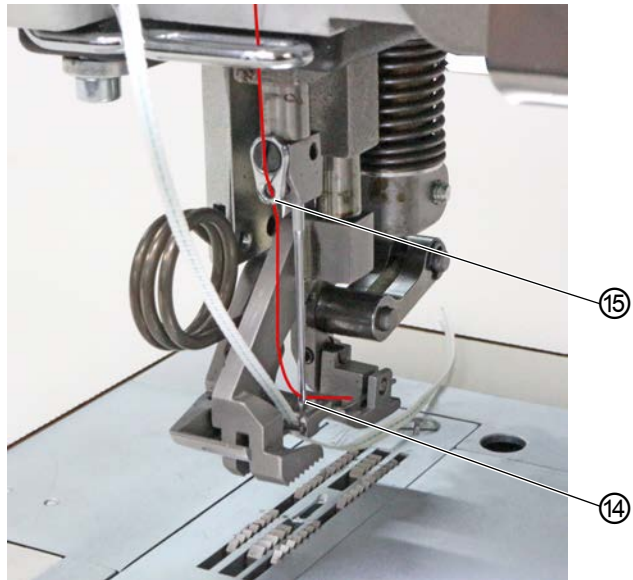

(14)- Needle eye

(15)- Thread guide



10. Insert the needle thread through thread guide (15).

11. Insert the needle thread through the needle eye (14) in such a way that the loose end points downward/faces the hook.

4.5 Threading the hook thread

WARNING



Risk of injury from moving, cutting and sharp parts!

Crushing, cutting and punctures are possible.

Only thread the hook thread with the machine switched off.

Fig. 7: Threading the hook thread (1)

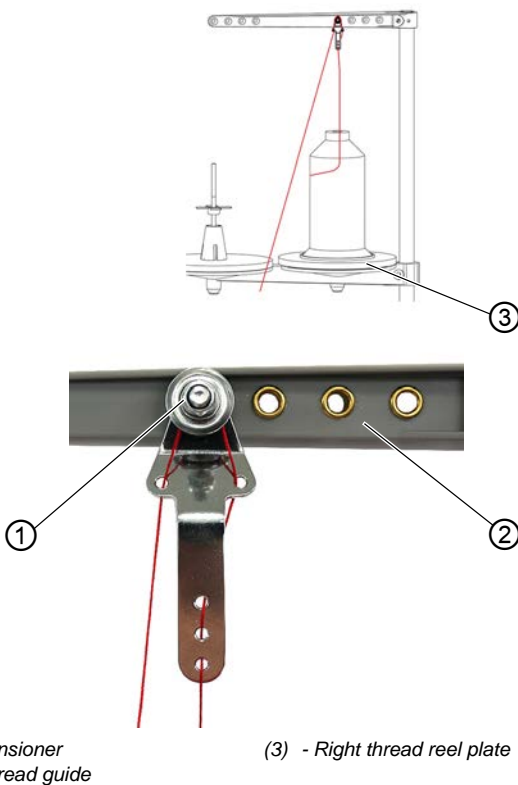

To thread the needle thread:

1. Fit the thread reel on the right thread reel plate (3).

2. Feed the needle thread through the thread guides as shown and guide it around the tensioner (1).



Important

The unwinding bracket (2) must stand directly above the thread reels.

Fig. 8: Threading the hook thread (2)

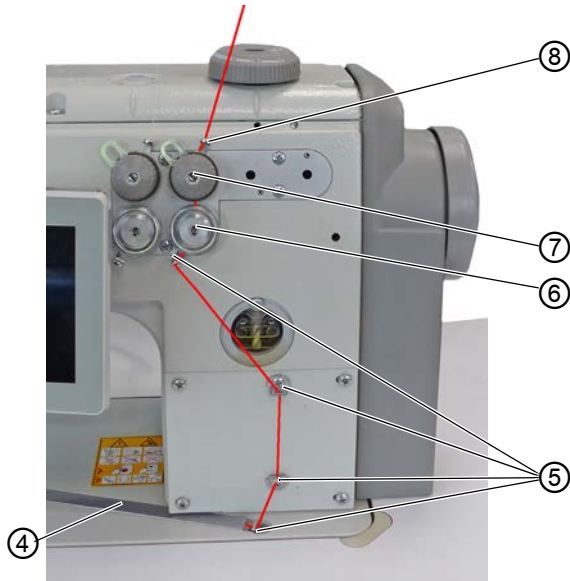

- | | |
|--------------------|--------------------|
| (4) - Hook cover | (7) - Tensioner |
| (5) - Thread guide | (8) - Thread guide |
| (6) - Tensioner | |



3. Feed the hook thread from the top through the thread guide (8).
4. Guide the hook thread counterclockwise around the tensioner (7).
5. Guide the hook thread clockwise around the tensioner (6).
6. Insert the hook thread through the 4 thread guides (5).
7. Open the hook covers on the left and the right next to the throat plate.
8. Open the thread channel (4).
9. Feed the hook thread through the thread channel (4).

10. Pull the hook thread from the rear under the cover plate of the thread channel (4).

Fig. 9: Threading the hook thread (3)

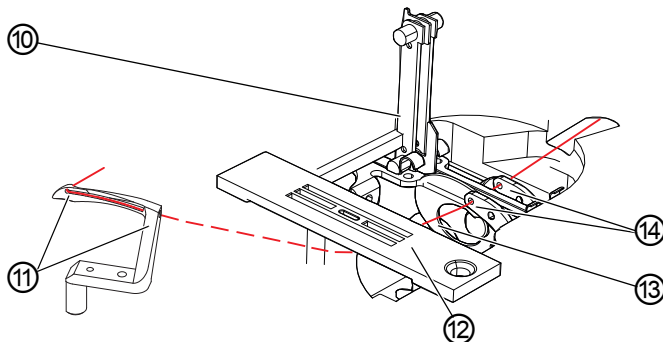

- (9) - Hook thread bobbin case retainer (12) - Thread take-up disk
 (10) - Hook hole (13) - Hook thread guide
 (11) - Throat plate



11. Remove the cover plates to the right and left of the throat plate (11).
12. Lift the hook thread bobbin case retainer (9) from its latching.
13. Turn the handwheel to position **B** in such a way that the thread take-up disk (12) is set accordingly.
14. Insert the hook thread from the right to the left through the holes of the hook thread guide (13).
15. Turn the handwheel until the hook holes (10) are accessible.
16. Insert the hook thread from the right to the left through the hook holes (10) before pulling it out towards the rear by approx. 3 cm.

Fig. 10: Threading the hook thread (4)

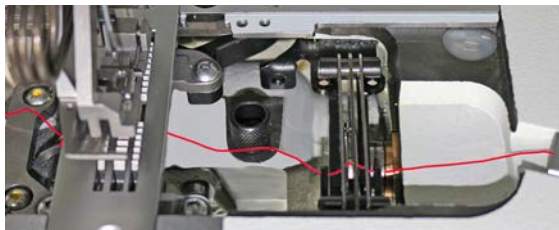

17. Press down and lock into place the hook thread bobbin case retainer (9).
18. Insert the hook covers again on the left and the right next to the throat plate (11).

4.6 Threading the reinforcement tape

The reinforcement tape is used to reinforce the seam and support ruffling. The reinforcement tape can be fed in 2 ways:

- Tape feeder at the top (at the machine head)
- Tape feeder at the bottom (under the tabletop)

The machine is equipped with either type of tape feeder. If fed from the top, the reinforcement tape is sewn on top of the material. If fed from the bottom, the reinforcement tape is sewn under the material.

4.6.1 Threading the reinforcement tape from the top

Fig. 11: Threading the reinforcement tape from the top (1)

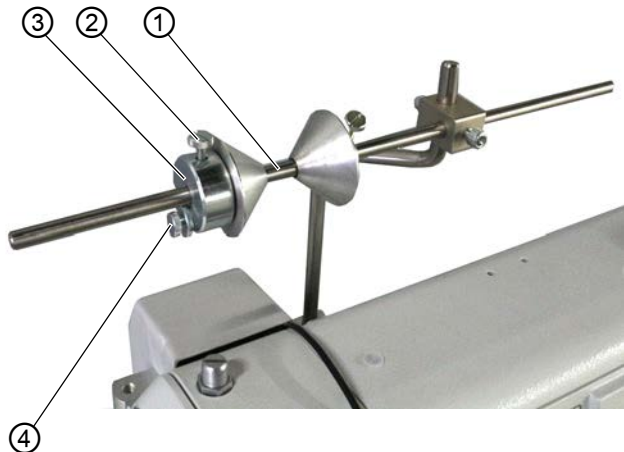

(1) - Bar
(2) - Screw

(3) - Brake element
(4) - Screw



To thread the reinforcement tape from the top:

1. Loosen the screw (2) and pull it off the bar (1) towards the left together with the brake element (3).
 2. Fit the tape roll onto the bar (1).
 3. Slip the brake element (3) back onto the bar (1).
 4. Tighten the screw (2).
- ☞ Now, the tape roll can no longer slip off the bar.

- Use the screw (4) to set how strongly the tape roll is supposed to be braked (📖 p. 46).

Fig. 12: Threading the reinforcement tape from the top (2)

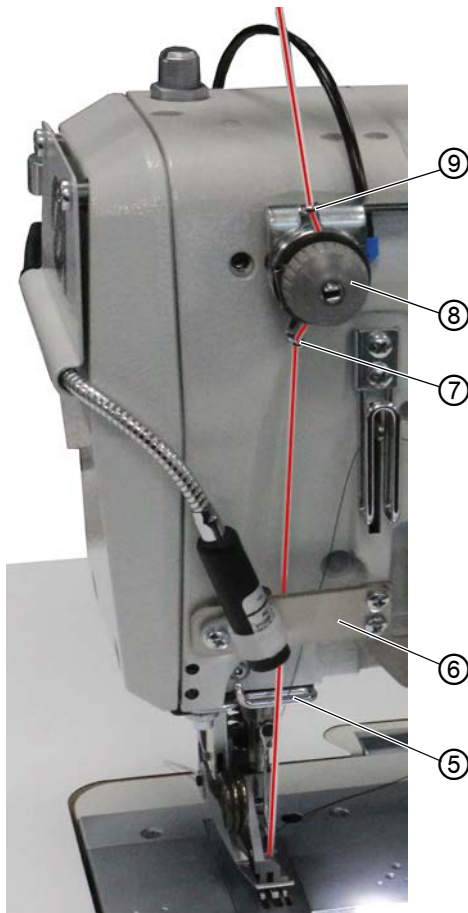

- | | |
|--------------------|------------------|
| (5) - Thread guide | (8) - Tensioner |
| (6) - Bracket | (9) - Tape guide |
| (7) - Tape guide | |



- Feed the reinforcement tape from the tape roll to the tape guide (9) and thread it from top to bottom.
- Feed the reinforcement tape clockwise through the tensioner (8).

8. Feed the reinforcement tape from top to bottom through the tape guide (7).
9. Feed the reinforcement tape downwards from the top behind the bracket (6).
10. Guide the reinforcement tape IN FRONT OF the thread guide (5) from the top.
- ✎ DO NOT guide the reinforcement tape behind the thread guide (5) to keep the reinforcement tape and the needle thread from becoming entangled.

Fig. 13: Threading the reinforcement tape from the top (3)

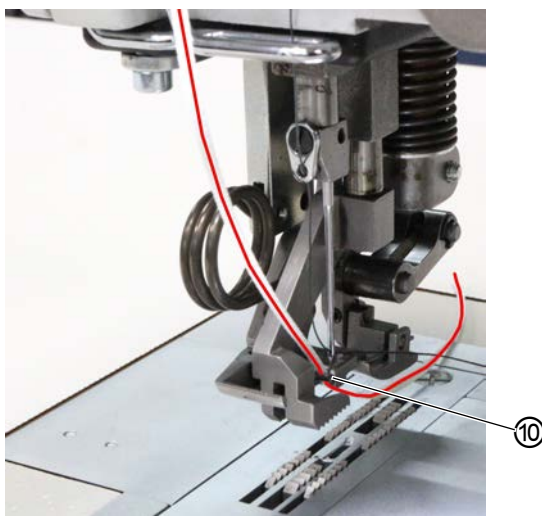

(10)- Tape guide



11. Feed the reinforcement tape from top to bottom through the tape guide (10).
- ✎ The reinforcement tape has been fully threaded from the top.
12. Guide the reinforcement tape towards the rear in the same way as the needle thread.

4.6.2 Threading the reinforcement tape from the bottom

Fig. 14: Threading the reinforcement tape from the bottom (1)

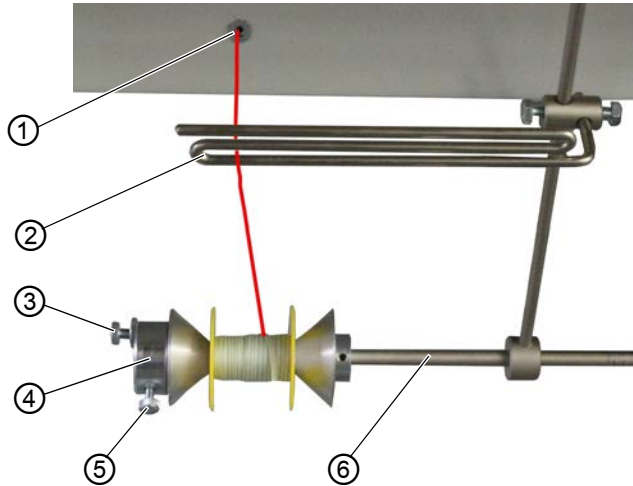

- | | |
|---------------------------|---------------------|
| (1) - Slot in the oil pan | (4) - Brake element |
| (2) - Tape guide | (5) - Screw |
| (3) - Screw | (6) - Bar |



To thread the reinforcement tape from the bottom:

1. Loosen the screw (5) and pull it off the bar (6) towards the left together with the brake element (4).
2. Fit the tape roll onto the bar (6).
3. Slip the brake element (4) back onto the bar (6).
4. Tighten the screw (5).
- ↳ Now, the tape roll can no longer slip off the bar.
5. Use the screw (3) to set how strongly the tape roll is supposed to be braked (📖 p. 46).
6. Feed the reinforcement tape up from the tape roll to the tape guide (2) and thread it.
7. Tilt the machine head (📖 p. 134).
8. Feed the reinforcement tape up through the slot in the oil pan (1).

Fig. 15: Threading the reinforcement tape from the bottom (2)

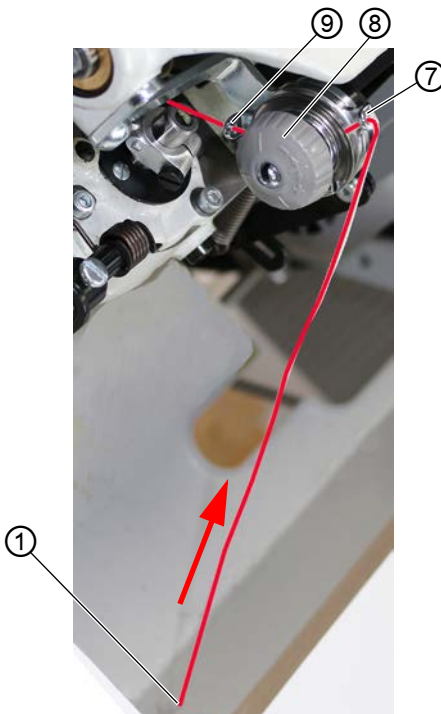

(1) - Slot in the oil pan
(7) - Tape guide

(8) - Tensioner
(9) - Tape guide

9. Feed the reinforcement tape from the slot in the oil pan (1) through the tape guide (7).
10. Feed the reinforcement tape clockwise through the tensioner (8).
11. Insert the reinforcement tape through the tape guide (9).

Fig. 16: Threading the reinforcement tape from the bottom (3)

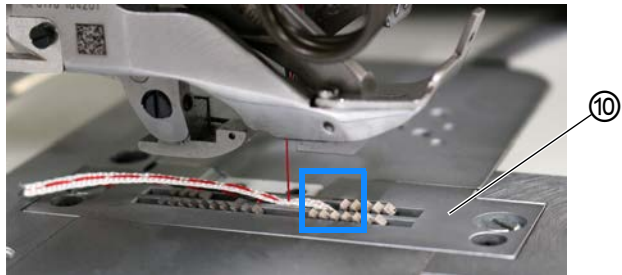

(10)- Throat plate



12. Feed the reinforcement tape, as shown, from the bottom through the throat plate (10).
13. Guide the reinforcement tape towards the rear in the same way as the needle thread.
14. Erect the machine head again ( p. 134).

Fig. 17: Threading the reinforcement tape from the bottom (4)

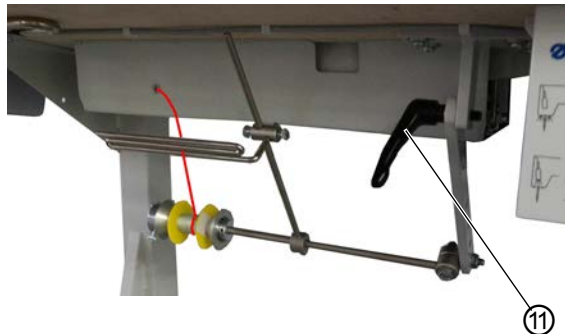

(11)- Lever

15. Loosen the lever (11) to set the rod of the bottom tape guide.
 -  The bottom feeder must not impair free movement during sewing.
16. Lock the lever (11) back into position.

4.7 Thread tension

Together with the hook thread tension, the needle thread tension influences the final seam pattern. With thin sewing material, excessive thread tension can lead to thread breakage.



Proper setting

The needle thread tension must be tighter than the hook thread tension. To ensure the proper setting, the hook thread tensioner is equipped with a spring made of thinner wire



Disturbance from incorrectly set thread tension

- Too tight: Crimping of the sewing material
- Too loose: Missing stitches

The thread tension is set at the control panel.

If 100 % thread tension is insufficient, the thread pre-tension can be supplemented ( p. 43). To this end, the tensioner elements of the thread pre-tensioner are set closer together. The tensioner elements of the thread pre-tensioner are, otherwise, always open.

4.7.1 Setting the needle thread quantity

WARNING



Risk of injury from moving parts!

Crushing possible.

Switch off the machine before setting the needle thread quantity.

The needle thread quantity released for stitch formation is determined by the position of the needle thread regulator. The required needle thread quantity depends on the thickness of the sewing material, the thread strength, and the seam type.

In addition, the threading procedure varies with the needle threads and the types of seams used.

Fig. 18: Setting the needle thread quantity (1)

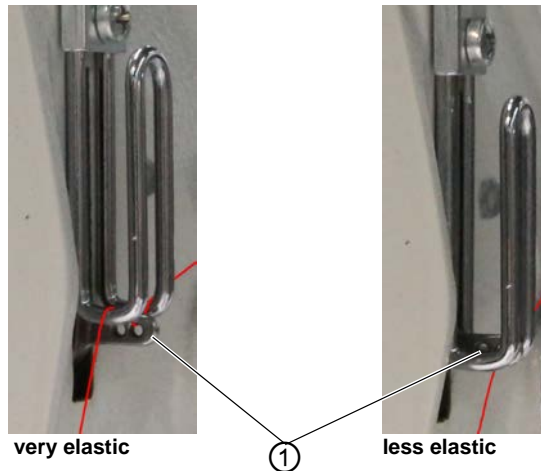

(1) - Thread lever



Proper setting

- **Less elastic threads:**

The thread lever (1) is visible just above the needle thread regulator when at bottom dead center.

- **Very elastic threads:**

The thread lever (1) is visible just below the needle thread regulator when at bottom dead center.

Fig. 19: Setting the needle thread quantity (2)

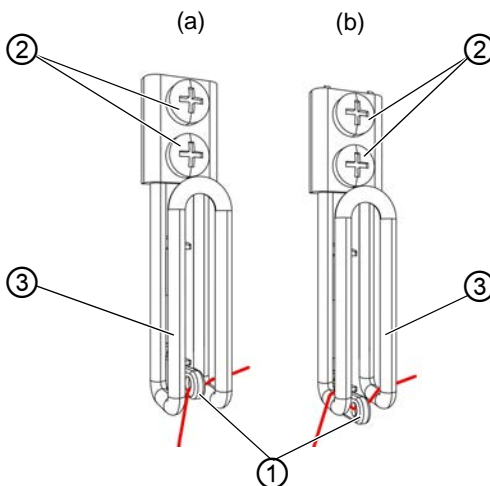

(1) - Thread lever
(2) - Screw

(3) - Needle thread regulator



To set the needle thread quantity:

1. Turn the handwheel until the thread lever (1) reaches its bottom dead center.
2. Loosen the screws (2) of the needle thread regulator (3).
3. Move the needle thread regulator (3) to the correct position.
 - **For tight and normal seams (detail image (a)):**
Feed the needle thread through the hole of the thread lever (1) and then directly downwards.
 - **For elastic seams (detail image (b)):**
Feed the needle thread through hole of the thread lever (1) and then via the left bar of the needle thread regulator (3).
4. Tighten the screws (2) for the needle thread regulator (3).

4.7.2 Setting the hook thread quantity

The hook thread quantity released is determined by the position of the hook thread take-up. The hook thread take-up adapts the hook thread quantity to each set stitch length to allow for the best possible stitch pull at any length and even with stitch condensing enabled.

The hook thread take-up can be adjusted continuously on a scale from **0** to **5**. The larger the value, the greater the released thread quantity and the more elastic the seam.



Proper setting

The proper setting is dependent on the stitch length and the seam type.

You need to ensure, especially when applying extreme settings, that the needle reliably plunges into the thread triangle:

- Elastic seam (3) with a very short stitch length = scale 5
- Tighter seam (1) with a significantly increased stitch length = scale 0

Fig. 20: Setting the hook thread quantity (1)

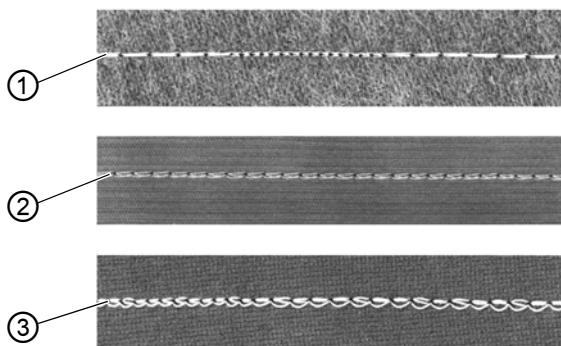

(1) - Tight seam
(2) - Normal seam

(3) - Highly elastic seam
(balloon stitch)



Disturbance if hook thread quantity to too high

- Missing stitches
- Hook thread pops out of the thread take-up disk

Fig. 21: Setting the hook thread quantity (2)

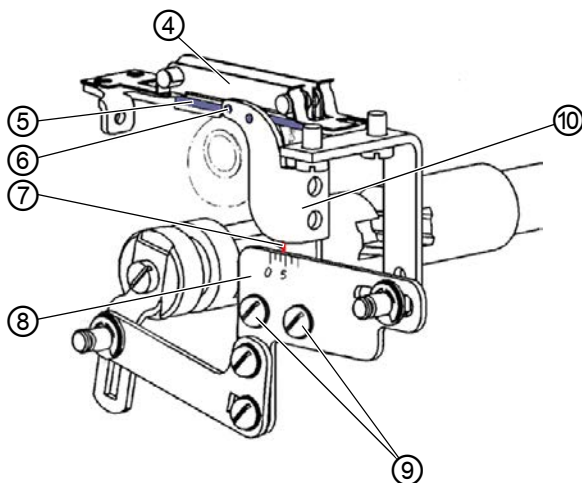

- | | |
|-----------------------------------|----------------------------|
| (4) - Thread bobbin case retainer | (8) - Scale |
| (5) - Lower bar | (9) - Screw |
| (6) - Hole | (10) - Hook thread take-up |
| (7) - Front edge | |



To set the hook thread quantity:

1. Tilt the machine head ( p. 134).
2. Loosen the screws (9).
3. Move the hook thread take-up (10).
 - Tighter seam = move the front edge (7) towards the **0** on the scale (8)
 - More elastic seam = move the front edge (7) towards the **5** on the scale (8)



Important

Fig. 22: Setting the hook thread quantity (3)

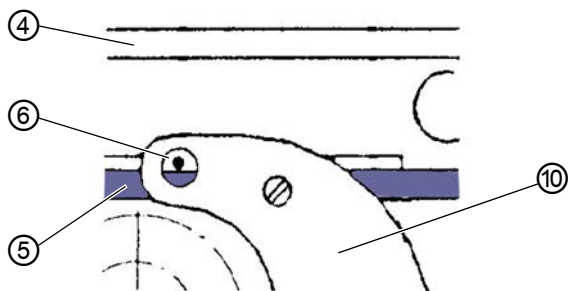

- | | |
|-----------------------------------|----------------------------|
| (4) - Thread bobbin case retainer | (6) - Hole |
| (5) - Lower bar | (10) - Hook thread take-up |

Do not alter the height of the hook thread take-up (10).

The hole (6) must always remain above the lower bar (5) of the thread bobbin case retainer (4).

4. Tighten the screws (9).
5. Erect the machine head ( p. 134).

4.7.3 Setting thread pre-tensioner/tape tensioner

NOTICE

Production of loose stitches!

When sewing corners with active tensioner lift and simultaneous sewing foot lift, the machine will produce a loose stitch.

Do not activate the tensioner lift when lifting the sewing feet unless the sewing feet are NOT lifted during the seam.

Fig. 23: Setting thread pre-tensioner/tape tensioner (1)



(1) - Tensioner element
(needle thread)

(2) - Tensioner element
(hook thread)

The additional tape tensioner of the reinforcement tape is set at the tensioner elements in the same way as the needle and hook thread tensioners.

Fig. 24: Setting thread pre-tensioner/tape tensioner (2)

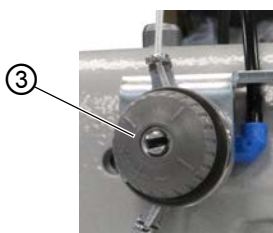

(3) - Tensioner element
(upper tape tensioner)

Fig. 25: Setting thread pre-tensioner/tape tensioner (3)

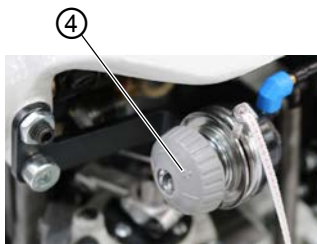

(4) - Tensioner element
(lower tape tensioner)



To **increase** the thread pre-tension/tape tension:

1. Turn the tensioner element (1)/(2)/(3)/(4) clockwise in the **+** direction.
- ↳ The tensioner element (1)/(2)/(3)/(4) is closed.



To **reduce** the thread pre-tension/tape tension:

1. Turn the tensioner element (1)/(2)/(3)/(4) counterclockwise in the **-** direction.
- ↳ The tensioner element (1)/(2)/(3)/(4) is opened.

For information on how to set a larger amount of thread in the seam, see  p. 38.



Information

The tape tensioner for the reinforcement tape is best set when switched on, allowing you to test the setting directly during sewing.

For instructions on how to turn the tape tensioner of the reinforcement tape on/off, refer to ( p. 45).

4.8 Switching the tape tensioner for the reinforcement tape on/off

Depending on its equipment, the machine may be equipped with a lower or an upper tape feeder.

Fig. 26: Switching the tape tensioner for the reinforcement tape on/off (1)

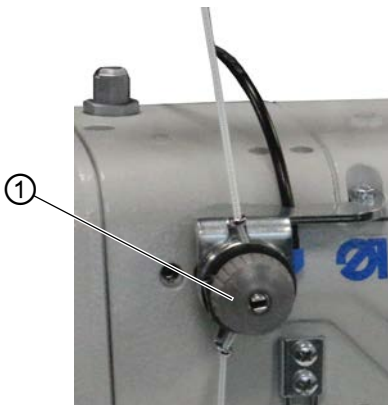

(1) - Tensioner element (top)

Fig. 27: Switching the tape tensioner for the reinforcement tape on/off (2)



(2) - Tensioner element (bottom)



On both tape feeders, the reinforcement tape is fed through a tensioner element (1)/(2), which can be closed and opened as necessary.

The tape tensioner is switched off for ruffling values of **0-7**. The tape tensioner is switched on automatically for ruffling values of **8** and higher; the button (3) will then light up. The tape tensioner can be switched off at any time.

The tape tensioner is set in the same way as needle thread pre-tensioner and hook thread pre-tensioner ( p. 43).



Information

The ruffling value at which the tape tensioner is switched on automatically can be adjusted on the control panel ( p. 82) and ( p. 99).

4.9 Setting the tape brake



Information

If the reinforcement tape is not sewn straight relative to the seam, the tape feeder may be too loose and/or the reinforcement tape tension may be too low.

Ruffling is increased if the tape tension is too high and/or the tape brake is set too tight.

The reinforcement tape tension can be set by adjusting the tape tensioner ( p. 45). The tape brake regulates the tape feeder.

Depending on its equipment, the machine may be equipped with a lower or an upper tape feeder for the reinforcement tape ( p. 31).

To ensure that the reinforcement tape is fed in a way that achieves straight seam support and the desired ruffling value, the tape brake must be set accordingly.

The principle that is used to brake the tape feeder is identical for the upper and the lower feeder.

Fig. 28: Setting point in time for cutting (1)

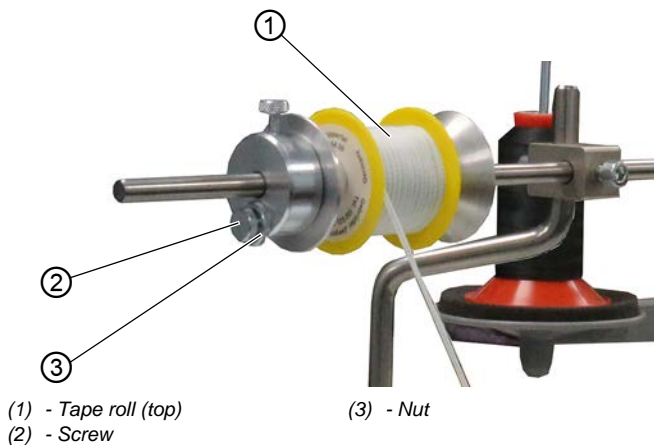
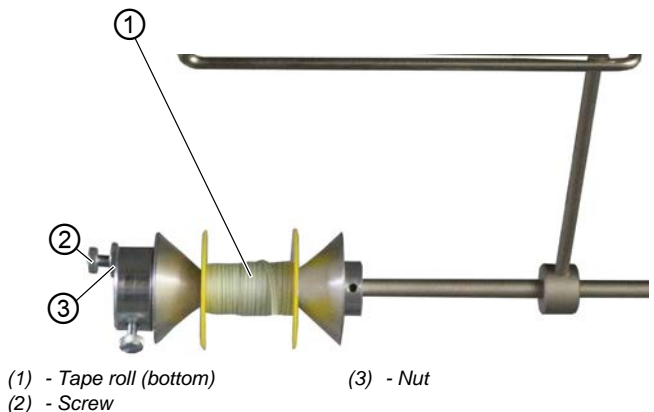

Fig. 29: Setting point in time for cutting (2)



To set the upper/lower tape brake:

1. Loosen the nut (3).
2. To reduce the force of the tape brake, loosen the screw (2).
3. To increase the force of the tape brake, tighten the screw (2).
4. To lock the screw (2) in position, tighten the nut (3).

4.10 Locking the sewing feet at top dead center

CAUTION



Risk of injury from moving parts!

Crushing possible.

Do not reach under the sewing feet.

Fig. 30: Locking the sewing feet at top dead center



(1) - Locking button



To lock the sewing feet at top dead center:

1. To lift the sewing feet, press and hold the pedal in position **-1** or position **-2**.
 - ↳ The sewing feet remain lifted for as long as the pedal is kept in position **-1** or position **-2**.
2. Press the locking button (1) and keep it pressed.
3. Release the pedal (position **0**).
4. Release the locking button (1).
 - ↳ The sewing feet are locked at top dead center.



To remove the lock:

1. Press the pedal to position **-1**.
 2. Release the pedal (position **0**).
- ↳ The locking button (1) disengages, canceling the lock.

4.11 Setting the sewing foot stroke

The sewing foot stroke is adjustable over a range of 2-7 mm by turning the adjusting wheel.

The increased sewing foot stroke can be switched on and off using the left button ( p. 53).

Fig. 31: Setting the stroke height



(1) - Adjusting wheel

(2) - Marking

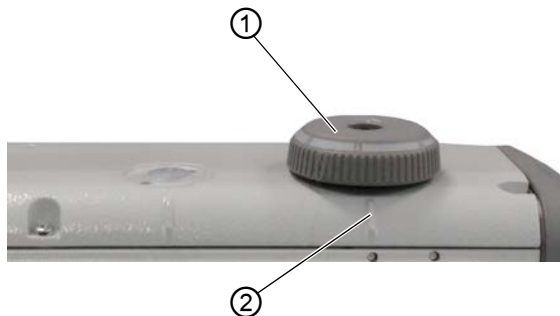

To set the sewing foot stroke:

1. Set the sewing foot stroke:
 - Increase the sewing foot stroke Turn the adjusting wheel (1) counterclockwise
 - Reduce the sewing foot stroke: Turn the adjusting wheel (1) clockwise
- ↳ The marking (2) indicates the selected stroke height.

4.12 Setting the sewing foot pressure

NOTICE

Property damage may occur!

Damage to the sewing material.

Set the sewing foot pressure such that the sewing material can neither slip nor become damaged.

Fig. 32: Setting the sewing foot pressure



(1) - Screw

(2) - Nut



To set the sewing foot pressure:

1. Loosen the nut (2).
2. Set the sewing foot pressure:
 - Increase the sewing foot pressure:
Turn screw (1) clockwise
 - Reduce the sewing foot pressure:
Turn screw (1) counterclockwise
3. Tighten the nut (2).



Important

Major changes to the sewing foot pressure require a recalibration of the ruffling device (📖 *Service Instructions*).

4.13 Using the knee button during sewing

The knee button can be used to switch a function on and off during sewing.

Fig. 33: Using the knee button during sewing (1)



(1) - Toggle switch

(2) - Knee button

The position of the toggle switch (1) indicates whether the function is switched on or off.

0 = function is switched off

1 = function is switched on

The function assigned to the knee button (2) at the factory is **Set selected ruffling value to 0 and vice versa.**



Information

The knee button (2) can also be assigned other functions via the technician level on the control panel.

Fig. 34: Using the knee button during sewing (2)

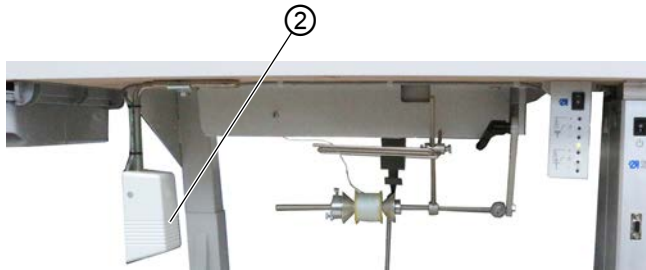

(2) - Knee button



To use the knee button during sewing:

1. Press the knee button (2).
- ↳ The ruffling value is reset to 0.
2. Press the knee button (2) again.
- ↳ The previous ruffling value is restored.

4.14 Switching maximum stroke on and off

The maximum stroke can be selected via the control panel ( p. 77).

4.15 Switching the edge cutter on and off

CAUTION



Risk of injury at exposed blade!

There is a risk of sustaining injuries at the exposed blades.

Do not reach into the cutting area.

The machine is equipped with an edge cutter. In manual mode, the edge cutter can be switched on and off at any time. The top blade is designed such that it will penetrate reliably even if activated during sewing. The edge cutter can be adjusted via the control panel ( p. 59).

4.16 Switching on and off the sewing lamp

The sewing lamp switches on and off independent of the main switch.

Fig. 35: Switching on and off the sewing lamp

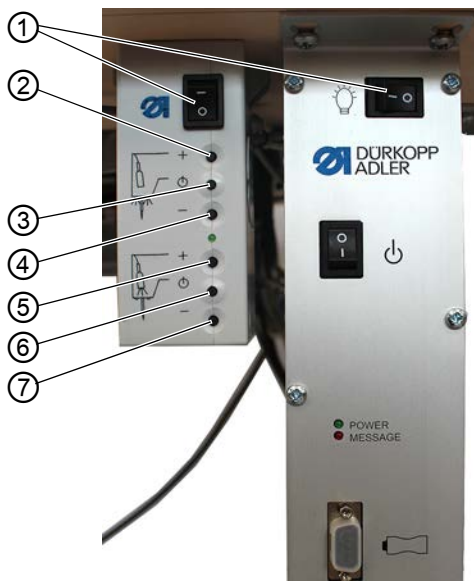

- (1) - Switch
- (2) - Button
- (3) - Button
- (4) - Button

- (5) - Button
- (6) - Button
- (7) - Button



To switch on the sewing lamp:

1. Set both switches (1) to position I.
- ↳ The sewing lamp transformer is now powered on.
2. Press the button (6).
- ↳ The sewing lamp illuminates.
3. Use the (5) or (7) button to set the brightness level.



To switch off the sewing lamp:

1. Press the button (6).
- ↳ The sewing lamp goes out.

2. Set both switches (1) to position **0**.
 The sewing lamp transformer is now powered off.
-

**Information**

The sewing lamp transformer allows for the connection of a second LED light. The buttons (2), (3) and (4) are used to switch the additional LED light on and off and to set the brightness level.

The scope of delivery does not include a second LED light.

4.17 Setting the stitch length

The stitch length is set at the control panel ( p. 59).

In every seam program, the stitch length can be set individually for each seam section.

4.18 Sewing

WARNING



Risk of injury from moving parts!

Crushing injuries may be sustained while lowering the sewing feet.

Do NOT put your hands under the lifted sewing feet.

Fig. 36: Sewing (1)

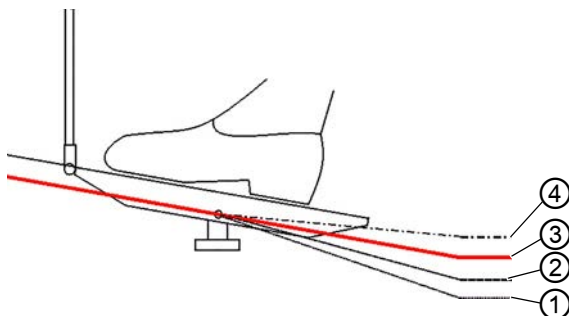

(1) - Position -2
(2) - Position -1

(3) - Position 0
(4) - Position 1

The machine offers 2 sewing modes:

- Manual mode
- Automatic mode

Use the pedal to start and control every sewing process.

Initial situation



The pedal is released (position **0**).

☞ The machine is at a standstill.

The needle is up, and the sewing feet are down.



To position the sewing material:

1. Press the pedal to position **-1**.
 The sewing foot is lifted.
2. Push the sewing material into the initial position.
3. Release the pedal (position **0**).
 The sewing foot lowers onto the sewing material.

At seam beginning



To start a seam:

1. Press the pedal forward to position **1**.
 The machine sews. The speed increases the further forward the pedal is pressed.

During sewing



To interrupt the seam:

1. Release the pedal (position **0**).
 The machine stops.
Needle and sewing foot are up / down.



To continue the seam:

1. Press the pedal forward to position **1**.
 The machine continues to sew.

At seam end



To finish the seam:

1. To finish the seam, press the pedal completely backwards to position **-2**.
 The machine stops.
Needle and sewing feet are lifted and remain up as long as the pedal is kept in the **-2** position.

Fig. 37: Sewing (2)



(5) - Thread-pulling knife



2. Cut the reinforcement tape at the thread-pulling knife (5).
3. Remove the sewing material.

5 Programming Commander Pro

5.1 Commander Pro control panel

Fig. 38: Commander Pro control panel

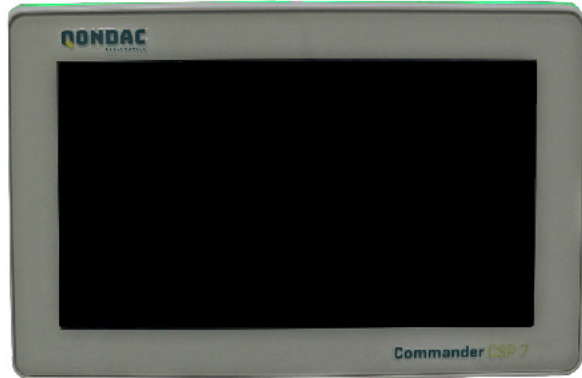

All settings in the software are performed using the Commander Pro control panel.



Information

If a value is entered that is not within the specified value range, the software will automatically adopt the limit value which is closest to your entry from the value range.

5.2 Navigating the Commander Pro control panel

You navigate the control panel by tapping the screen with your fingers. There is no need for an input device.

You can open menus by pressing the corresponding button with your finger. You switch between the different pages of the start screen by swiping with one finger.

You can modify the information displayed in the status bar (1). You can also adjust the tiles shown on the three pages of the main screen (2). You customize the information using the control panel settings,  p. 77.

Fig. 39: Navigating the Commander Pro control panel







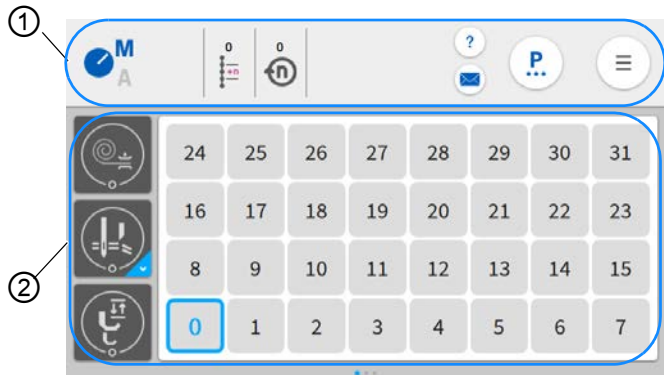







(1) - Status bar

(2) - Main screen

5.2.1 Symbols and tiles

Explanation of recurring symbols:

Icon	Meaning
 	The letter shown in blue is active. A = Automatic mode M = Manual mode Press the symbol to toggle between the two modes.
	Programming mode (access via the burger menu), see  p. 94.
	Parameters you can set in manual mode.

Icon	Meaning
	<p>Burger menu A window opens that lets you select Automatic mode, Manual mode, Programming mode or Settings.</p>
	<p>Context-sensitive help Start by pressing the gray question mark before pressing the area for which you need help - this brings up a pop-up window containing a Help text. Press anywhere to make the window disappear.</p>
	<p>Messages</p>
	<p>Bright tiles Parameters for which you can/must enter a numerical value. Values can be input by pressing.</p>
	<p>Dark tiles (latching) You can active or deactivate dark tiles encircled by a white line by tapping. You cannot set any values.</p>
	<p>Dark tiles (multifunction) You can active or deactivate dark tiles encircled by a white line and showing a blue triangle in the corner by pressing. A long press opens a menu that lets you input values.</p>
	<p>Dark tiles (hold to run) You cannot enter any values for dark tiles surrounded by a square white line. The function assigned to the tile is only active for as long as you press the tile.</p>
	<p>Grayed-out tiles Grayed-out tiles merely provide information. You can neither enter values nor active or deactivate these tiles.</p>

5.2.2 Entering values

You can input values using the buttons **+** or **-** or by typing on the integrated on-screen keyboard.

Values highlighted in red are invalid as they are not within the specified value range. If you enter invalid values, the software will automatically set the limit value of the value range.

5.2.3 Navigating the burger menu

You can open the burger menu with a press of the symbol .



Fig. 40: Navigating the burger menu

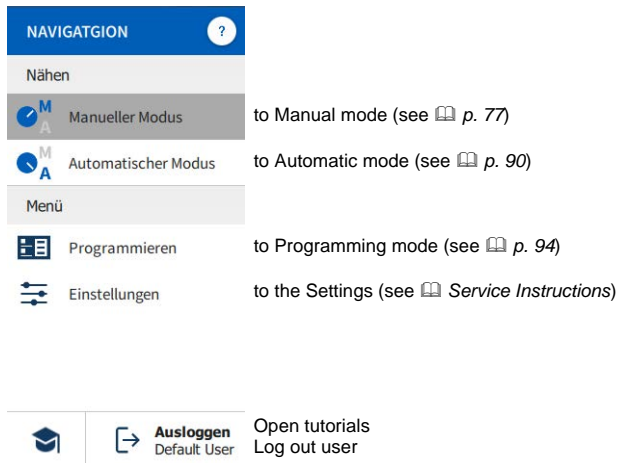

5.2.4 Navigation during the start of the control panel

You can access the languages and settings without having to wait for the control panel to finish starting up.

You can select these options as soon as their icons are displayed on the control panel. After entering your user login, you will be taken to the desired menu - depending on which option you selected.

Symbol	Explanation
	Language selection
	Skip intro
	Settings

5.3 User Management



The User Management section allows you to create users and roles with different authorizations.

The factory setting is such that the *Default User* will automatically be logged in when the machine starts and the control panel boots up. You can change this setting at the Technician level as needed.

The settings under User Management are only available to technicians ( p. 68).



To access User Management:



1. Press the symbol  to bring up the navigation pane.
 This opens the navigation interface.

Fig. 41: User Management (1)



(1) - Settings

2. Press *Settings* (1).

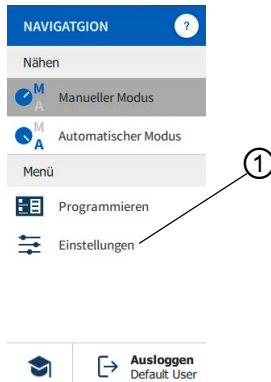
↳ This opens the Settings interface.

Fig. 42: User Management (2)

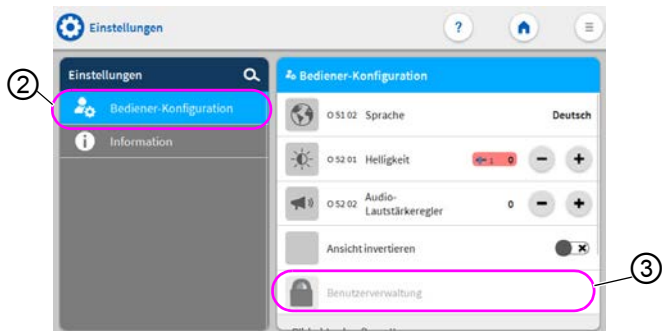

(2) - User Configuration

(3) - User Management

3. Press the item *User Configuration* (2) on the left.

4. Press the item *User Management* (3) on the right.

↳ Once you are logged in as a technician, the User Management interface opens.

5. Define the desired settings (for sample explanations, see [p. 68](#)).

5.3.1 User login

The factory setting of the software is such that the *Default User* will be logged in automatically when the machine is switched on. This neither requires the input of a password nor a USB key or an NFC chip. The following explains how you can switch users.



To access User Management:

1. Press the symbol  to bring up the navigation pane.
 - ↳ This opens the navigation interface.

Fig. 43: User login



(1) - Logout

2. Press *Logout* (1).
 - ↳ This opens the Login interface.

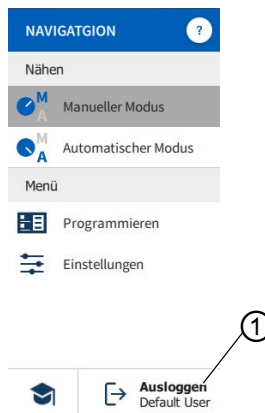

There are three ways to log in. The three options - including the necessary settings in the software - are described below.

5.3.1.1 Logging in with username and password

Assigning a username and password

To assign a username and password:

1. Create a new user in *User Management* and assign this user a username and password ( p. 73).
- ↳ The user can log in immediately with this login information.

Logging in with username and password

To log in with username and password:

1. Enter *username* and *password*.
 2. Press .
- ↳ If the login information is correct, the user will be logged in.

5.3.1.2 Logging in with a USB key

Assigning a USB key to a user

To assign a USB key to a user:

1. Select a user in *User Management* or create a new user ( p. 73).
 2. Press the item *Login using USB*.
- ↳ A new window opens.
3. Plug the USB key into one of the ports on the control panel.
 4. Select the USB key you wish to assign to the user for login purposes.

5. To assign the USB key, press *Pair*.
 - ↳ The window disappears, and the function *Login using USB* is active.

Login using USB

To log in with a USB key:

1. Plug the assigned USB key into the control panel.
 - ↳ If the USB key has been assigned correctly, the user will be logged in.

5.3.1.3 Logging in with NFC chip

Assigning an NFC chip to a user

To assign an NFC chip to a user:

1. Select a user in *User Management* or create a new user ( p. 73).
2. Press the item *Login with NFC chip*.
 - ↳ A new window opens.
3. To assign the NFC chip, hold the chip up to the control panel on the left-hand side.
 - ↳ The window disappears, and the function *Login with NFC chip* is active.

Logging in with NFC chip

To log in with an NFC chip:

1. Hold the assigned NFC chip up to the control panel on the left-hand side.
 - ↳ If the NFC chip has been assigned correctly, the user will be logged in.

5.3.2 Authorizations as *Default Technician*



The factory setting for the *Default Technician* requires that the technician enter their username and password (*technician*, 25483) to log in.

If selecting User Management as a *Default Technician* (📖 p. 63), you will be presented with the following interface:

Fig. 44: Authorizations as *Default Technician*

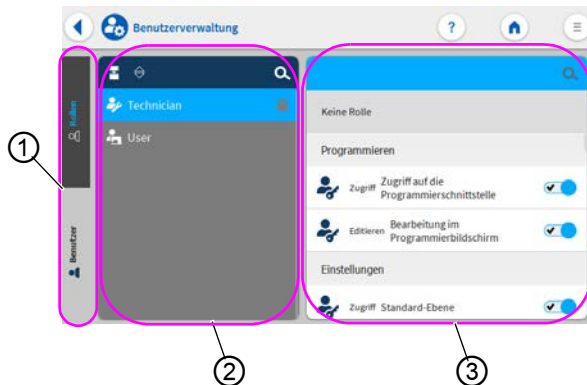

(1) - Tab for roles and users
(2) - List of roles/users

(3) - Settings for roles/users

On the left-hand side, you can select between the tabs (1) reserved for roles (📖 p. 69) and users (📖 p. 73). Detailed explanations are provided further below. To the right of the tabs you will find the list (2) of created roles / users - varying with the tab (1) you selected. On the far left, you will find the settings (3) associated with the role/user you selected.

Explanation of role and user

Role	User
<p>A role defines which authorizations are permitted or forbidden. It is possible to assign more than one role to a single user. You need to be a user to log in; you cannot log in using a role.</p>	<p>You can log in as a user. A user can be assigned one or several roles - this is how they receive their authorizations.</p>

5.3.2.1 Managing roles

If selecting User Management as a *Default Technician* (📖 p. 63), you will be presented with the following interface:

Fig. 45: Managing roles

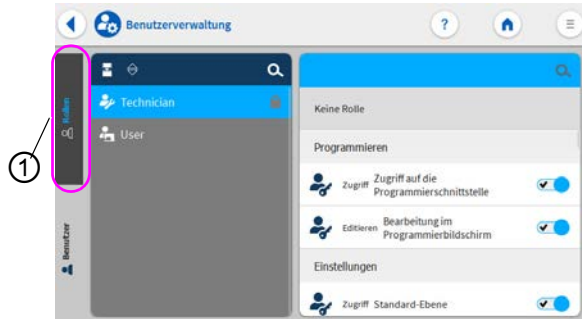

(1) - Tab for roles

Press the tab (1) reserved for the *Roles* on the left-hand side.

Deleting a role



To delete a role:

1. Press the desired role.
 - ↳ The role is highlighted in blue.
2. Press .
 - ↳ The role disappears from the list; it has been deleted.



Information

Roles with a  symbol behind their names have been created at the factory. They cannot be deleted.

Creating/deriving a new role



To create a new role:

1. Press  (only a role with fewer or equal authorizations than your own).
 - ↳ The list shows a new role.
2. Define the settings for the role (see table below).



Information

When logged in as a *Default Technician*, you can only select role derivations up to the role of *Technician*. You can adjust this setting in the authorizations of the roles (table below).

Settings of the roles

Read/Edit/Access	Menu item
Parent role	
Select from which role the new role is supposed to be derived. The selection shows all previously created roles.	
Programming	
Access	Access the programming ui
Edit	Edit on the programming screen
Settings	
Access	Standard level
Access	Technician level
Edit	Monitor sewing process
Manual mode	
Edit	Bartack enabled
Edit	Status bar

Read/Edit/Access	Menu item
Edit	Main screen
Access	Role Main Screen
Access	Role Status Bar
Access	Switch to automatic mode
Access	Parameter View
Edit	Manual bartack
Edit	Sewing foot lifted
Edit	Needle stop position
Edit	Bobbin Wind mode
Edit	Segment abort
Edit	Edge trimmer
Edit	2 nd Edge Guide Position
Edit	2 nd Edge Guide Height
Edit	Edge Guide reference position
Edit	Stitch length
Edit	Switch Stitch Length
Edit	Needle thread tension
Edit	Switch Thread Tension
Edit	Sewing foot pressure
Edit	Switch Foot Stroke Alternation
Edit	Bartack Toggle
Edit	Max. Speed
Edit	Bartack Needle Half Stitch
Edit	Enabled Thread Trim
Edit	Needle thread clamp

Read/Edit/Access	Menu item
Edit	Threading Mode
Edit	Light barrier
Edit	Reset Bobbin Counter
Edit	Seam Center Guide
Automatic mode	
Access	Program selection
Edit	Stitch length correction factor
Edit	Needle thread tension correction factor
Sewing	
Edit	Enable multi functional tiles
Edit	Flat Sew
User Management	
Edit	Current user
Edit	Roles up to technician
Edit	Users up to technician
Edit	Auto Login Editable

5.3.2.2 Managing users

If selecting User Management as a *Default Technician* (📖 p. 63), you will be presented with the following interface:

Fig. 46: Managing users (1)

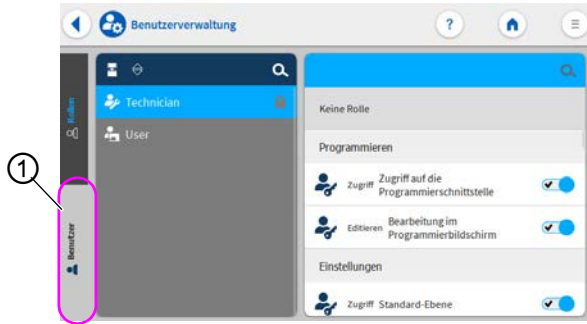

(1) - Tab for users

Press the tab (1) reserved for the *Users* on the left-hand side. This interface appears:

Fig. 47: Managing users (2)

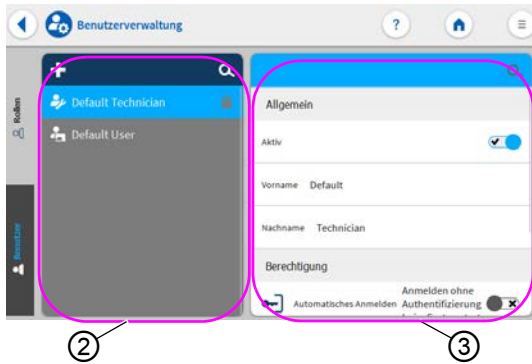

(2) - List of users

(3) - Settings of the user

The left-hand side holds a list of all users (2) that have been created. When pressing a user in this section, you will see on the right-hand side which settings (3) have been defined for the selected user.

Deleting a user



To delete a user:

1. Press the desired user.
 - ↳ The user is highlighted in blue.
2. Press .
 - ↳ The user disappears from the list; it has been deleted.



Information

Users with a  symbol behind their names have been created at the factory. They cannot be deleted.

Creating a new user





To create a new user:

1. Press .
 - ↳ The list shows a new user.
2. Define the settings for the user (see table below).

Settings of the user

Icon	Setting	Explanation
General		
	<i>Active</i>	ON/OFF
	<i>First name</i>	Name of the user, NOT to be confused with the data used for logging in!
	<i>Name</i>	
Authorization		
	<i>Auto-Login</i>	Login without authentication at startup

Icon	Setting	Explanation
Roles (📖 p. 69)		
	<i>Technician</i>	Slider control active/inactive; for assigning the role
	<i>User</i>	Slider control active/inactive; for assigning the role



Information

When logged in as a *Default Technician*, you can only assign roles up to the role of *Technician*. You can adjust this setting in the authorizations of the roles (📖 p. 69).

5.4 Software operating modes

The software of the control panel offers various operating modes:

- **Manual mode**

Manual mode is the simplest operating mode. There are no programs/seam programs and no inputs for individual seam sections.

Changes to the sewing foot pressure, stroke height, stitch length, needle thread tension and, also, the activation of other functions are always implemented immediately.

All the major sewing parameters can be changed manually during the sewing process.

- **Automatic mode**

Automatic mode allows for the execution of setups (seam program comprised of only one seam section) or complex seam programs (comprising 2 or more seam sections).

Seam programs are divided into individual seam sections. Each section is assigned its own individual stitch length, needle thread tension, etc.

- **Programming**

Programming mode makes it possible to create, adjust or delete a seam program in a quick and easy manner.

The individual modes and their uses are explained in detail later on.

5.5 Using Manual mode

In manual mode, no programs have been saved, allowing you to use all parameters in a variable manner.



To access the Manual mode:





1. Press the symbol  to bring up the navigation pane.
 This opens the navigation interface.

Fig. 48: Using Manual mode

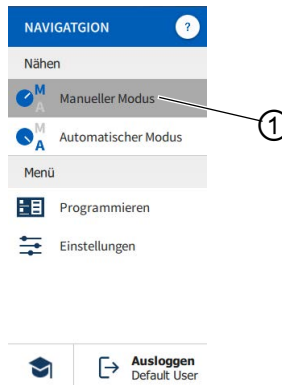

(1) - Manual mode

2. Press *Manual mode* (1).
 The interface of Manual mode opens.

5.5.1 Setting up the user interface

You can customize the arrangement of the tiles and the appearance of the status bar in Manual mode.

Arranging the tiles on the main screen

The main screen consists of three pages, which you can customize to your individual needs.



To adjust the tiles on the main screen:



1. Press the symbol  to bring up the navigation pane.
 This opens the navigation interface.

Fig. 49: Setting up the user interface (1)



(1) - Settings

2. Press *Settings* (1).

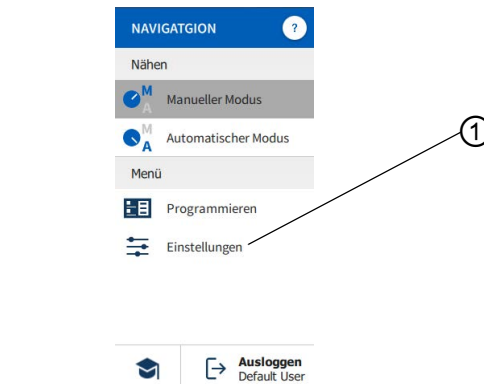
↳ This opens the Settings interface.

Fig. 50: Setting up the user interface (2)

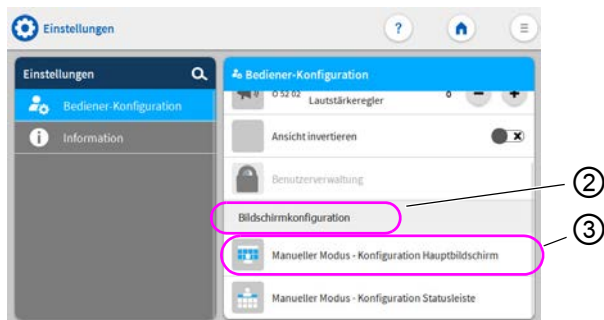

(2) - Screen configuration

(3) - Main screen configuration

3. Go to *Screen configuration* (2) and press on *Manual mode - Main screen configuration* (3).

↳ The interface used for configuring the main screen opens.

Fig. 51: Setting up the user interface (3)



4. Press and hold the desired tile and drag it to move it into or out of the grid.
5. Press to return to Settings or to return to Manual mode.

Adjusting the information displayed in the status bar

To adjust the appearance of the status bar:



1. Go to *Settings* (see above).

Fig. 52: Setting up the user interface (4)

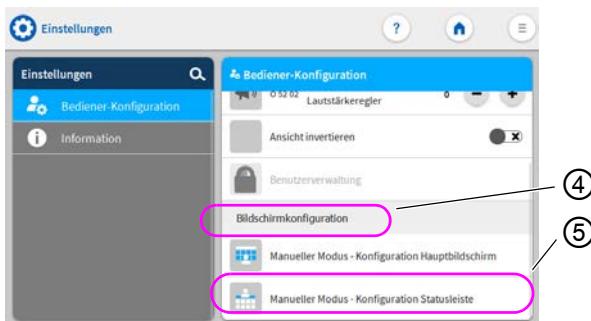



(4) - Screen configuration

(5) - Status bar configuration

2. Go to *Screen configuration (4)* and press on *Manual mode - Status bar configuration (5)*.
- ↳ The interface used for configuring the status bar opens.

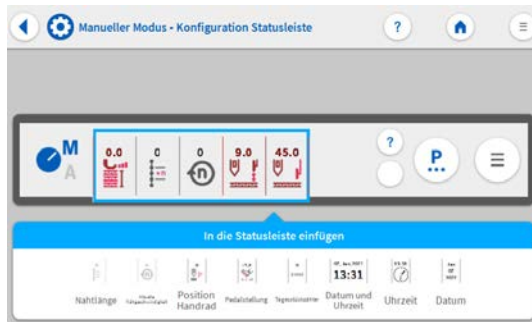
Fig. 53: Setting up the user interface (5)



3. Press and hold the desired symbol and drag it to move it into or out of the status bar.
4. Press  to return to Settings or  to return to Manual mode.

Default status bar settings

Fig. 54: Default status bar

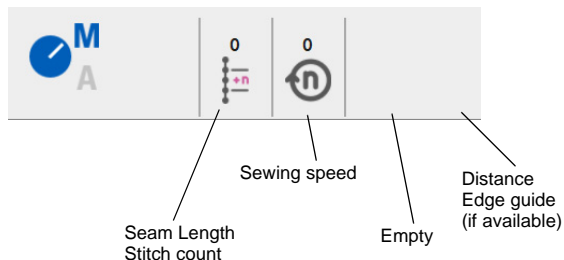

5.5.2 Setting the parameters



In Manual mode, you can set a variety of parameters. The functions and how they affect the parameters are described further below.



To access the parameter settings:

1. Press the symbol  to bring up the parameter pane.
- ↳ This opens the parameter settings interface.

Fig. 55: Setting the parameters







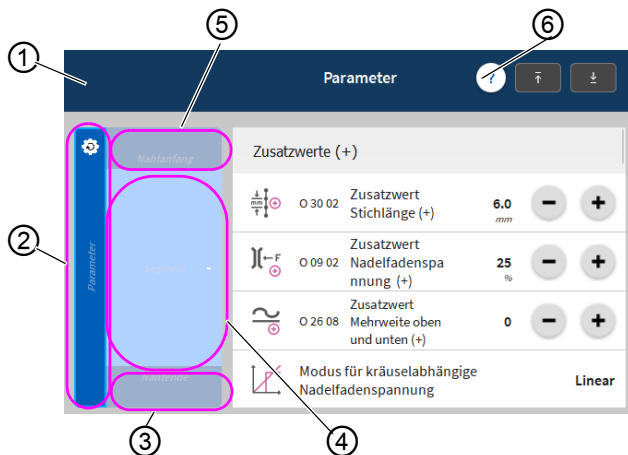











- | | |
|-----------------------------|------------------------------|
| (1) - Search | (4) - Parameters Segment |
| (2) - Parameters cross-seam | (5) - Parameters Seam Begin |
| (3) - Parameters Seam End | (6) - Context-sensitive help |





5.5.3 Setting the cross-seam *parameters*

There are various options for setting the cross-seam parameters. The following table lists all possible options.

Settings that are more complex and therefore require further explanation are described in more detail after the table.

Icon	Parameter	Setting
Additional values (+)		
	<p><i>Additional value stitch length (+)</i></p> <p>The 2nd value for the stitch length can be switched on using a button on the push button panel or the tile on the control panel.</p>	<p>Value range 00.0 – 12.0 [mm] (depending on sewing equipment and subclass)</p>
	<p><i>Additional value needle thread tension (+)</i></p> <p>The 2nd value for the needle thread tension can be switched on using a button on the push button panel or the tile on the control panel.</p>	<p>Value range 01 - 99 [%]</p>
	<p><i>Additional value fullness top and bottom</i></p>	<p>Value range 01 - 31</p>
	<p><i>Mode for ruffing-based needle thread tension</i></p>	<p>Value range Linear/Off</p>
	<p><i>Offset for ruffing-based needle thread tension</i></p>	<p>Value range -50 - 50 [%]</p>
	<p><i>Fullness Min.</i></p>	<p>Value range 00 - 31</p>
	<p><i>Fullness Max.</i></p>	<p>Value range 00 - 31</p>
	<p><i>Mode for ruffing-based hook thread tension</i></p>	<p>Value range Linear/Off</p>

Icon	Parameter	Setting
	<i>Offset for ruffing-based hook thread tension</i>	Value range -50 - 50 [%]
	<i>Fullness Min.</i>	Value range 00 - 31
	<i>Fullness Max.</i>	Value range 00 - 31
	<i>Mode for ruffing-based tape tension</i>	Value range Switching/Off
	<i>Fullness Min.</i>	Value range 00 - 16
Main Parameter		
	<i>Needle cooling</i>	Value range On/Off
	<i>Point position</i> The distance of the needle from the material can be adjusted to allow precise positioning of the sewing material when starting sewing. The value entered here corresponds to the degree number on the handwheel.	Value range 00 - 359 [°]
	<i>Flat Sew</i>	Value range 00 - 50
Correction speed effect		
	<i>Correction speed effect</i>	Value range On/Off

Icon	Parameter	Setting
	<i>Stitch length</i>	The stitch length changes slightly depending on the speed. For this reason, the stitch length can be adjusted at different speeds by the software.
	<i>Needle thread tension</i>	Depending on the speed, the needle thread tension can be adjusted at different speeds by the software.
Output		
	<i>Output 1-16</i>	(see  <i>p. 106</i>)

5.5.3.1 Setting the *Correction speed effect* parameters



Some parameters are affected by high speeds because of the resulting physical effects. To counteract these effects and to achieve consistent results, even at high speeds, adjustment factors can be set depending on the speed.

Overview of setting modes

The correction of the effects of high speeds can be identified in various modes and responded to depending on the setting. This general explanation can be applied to the following specific parameters.

Setting mode	Description
<i>linear</i>	In the linear setting, the size of the parameter increases or decreases steadily as the speed increases. The increase/decrease of the parameter depends on the limits set for the minimum and maximum speed.
<i>2. OnOff</i>	If a certain speed is exceeded, the 2 nd value of the parameter is activated. If the speed then falls below this level again, it switches to the base value for the parameter.
<i>2. On</i>	If a certain speed is exceeded, the 2 nd value of the parameter is activated. If the speed then falls below this level again, it does NOT switch to the base value for the parameter. Only after finishing the seam by cutting the thread is the base value for the parameter set again.

Setting options *Stitch length*

Menu item	Setting 1	Setting 2
<i>linear</i>	<i>Stitch length</i> Value range -50 – 50 [%]	Maximum stitch length variation reached at the upper speed limit.
	<i>Min. Sewing speed</i> Value range 0000 – 4000 [rpm] (depending on subclass)	Speed at which the increase/reduction of the stitch length should start.
	<i>Max. Sewing speed</i> Value range 0000 – 4000 [rpm] (depending on subclass)	Speed up to which the increase/reduction of the stitch length should occur.
<i>2. Value On/Off</i>	<i>Min. Sewing speed</i> Value range 0000 – 4000 [rpm] (depending on subclass)	Speed from which the 2 nd stitch length should be used.
<i>2. Value On</i>	<i>Min. Sewing speed</i> Value range 0000 – 4000 [rpm] (depending on subclass)	Speed from which the 2 nd stitch length should be used.



Setting options *Needle thread tension*

Menu item	Setting 1	Setting 2
<i>linear</i>	<i>Needle thread tension</i> Value range 00 – 99	Maximum needle thread tension reached at the upper speed limit.
	<i>Min. Sewing speed</i> Value range 0000 – 4000 [rpm] (depending on subclass)	Speed at which the increase in needle thread tension should start.
	<i>Max. Sewing speed</i> Value range 0000 – 4000 [rpm] (depending on subclass)	Speed up to which the increase in needle thread tension should occur.
<i>2. Value On/Off</i>	<i>Min. Sewing speed</i> Value range 0000 – 4000 [rpm] (depending on subclass)	Speed from which the 2 nd needle thread tension should be used.
<i>2. Value On</i>	<i>Min. Sewing speed</i> Value range 0000 – 4000 [rpm] (depending on subclass)	Speed from which the 2 nd needle thread tension should be used.

5.5.3.2 Setting the Outputs (*Output*) parameter



This parameter provides virtual outputs that can be assigned customer-specific functions. They can be used when customer-specific applications require a signal from the control of the machine.

This parameter cannot be used unless the virtual outputs have been assigned to a physical output at the Technician level. This requires that the parameter *Additional I/O Configuration* can be configured at the Technician level; for more details, refer to the explanation in the *Service Instructions*.

5.5.4 Setting the *Seam Begin* parameters

There are various options for setting the Segment Begin parameters. The following table lists all possible options.







Settings that are more complex and therefore require further explanation are described in more detail after the table.

Icon	Parameter	Setting
Settings of stitch condensing at seam beginning		
	<i>Stitch condensing at seam beginning</i>	Value range On/Off
	<i>Number of condensing stitches</i>	Value range 00 - 50
	<i>Factor</i>	Value range 25 - 100 [%]
	<i>Needle thread tension default</i>	Value range On/Off

5.5.5 Setting the *Segment* parameters

There are various options for setting the parameters in the segment. The following table lists all possible options.





Settings that are more complex and therefore require further explanation are described in more detail after the table.

Icon	Parameter	Setting
Seam Parameter		
	<i>Stitch length</i>	Value range 00.0 - 12.0 [mm] (depending on the sewing equipment and the subclass)
	<i>Needle thread tension</i>	Value range 01 - 99 [%]
	<i>Hook thread tension</i>	Value range 01 - 99 [%]
	<i>Fullness top and bottom</i>	Value range 01 - 31
	<i>Max. Speed</i> It is possible to reduce the maximum sewing speed at this point. The maximum sewing speed can be set in the software at the Technician level.	Value range 0050 – 3800 [rpm] (depending on subclass)
	<i>Sewing foot lift at stop</i>	Value range On/Off

5.5.6 Setting the *Seam End* parameters

There are various options for setting the Seam End parameters. The following table lists all possible options.

Settings that are more complex and therefore require further explanation are described in more detail after the table.

Icon	Parameter	Setting
Settings of stitch condensing at seam end		
	<i>Stitch condensing at seam end</i>	Value range On/Off
	<i>Number of condensing stitches</i>	Value range 01 - 50
	<i>Factor</i>	Value range 25 - 100 [%]
	<i>Needle thread tension default</i>	Value range On/Off

5.6 Using Automatic mode

Automatic mode is comprised of all stored programs.



To access the Automatic mode:



1. Press the symbol  to bring up the navigation pane.
 This opens the navigation interface.

Fig. 56: Using Automatic mode (1)



(1) - Automatic mode

2. Press *Automatic mode* (1).

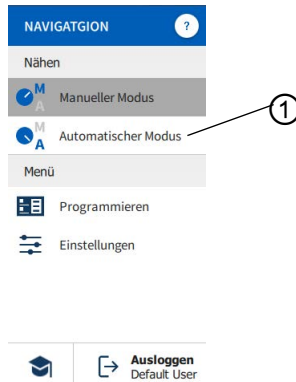



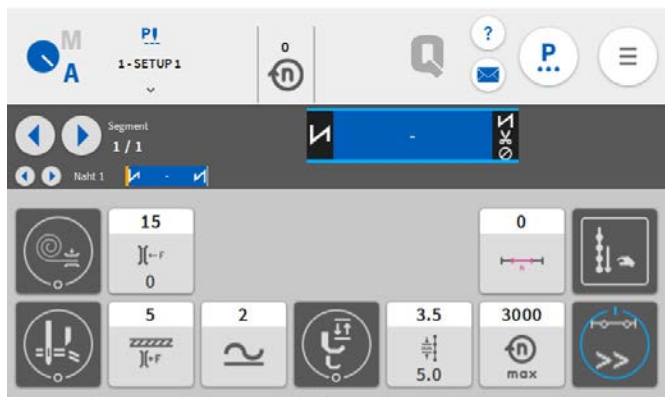

↳ The interface of Automatic mode opens. The program stored last is loaded.

The display shows tiles and information below the upper bar that vary with the selected program:

Fig. 57: Using Automatic mode (2)



Explanations of icons/symbols in Automatic mode:

Symbol/Icon	Meaning
	Selected program
	Move to the next or previous step in seams/ segments - also during the seam
	Seam/segment including information on the settings for seam beginning, seam and seam end
	Display of the entire program including its seams and segments.
	Adjustment factors that can still be adjusted during the seam
	Grayed-out tiles for information on the set parameters can be adjusted by programming (📖 p. 94).
	Dark gray tiles can only be activated or deactivated. You define which tiles will be visible by programming (📖 p. 94).

5.6.1 Sewing in Automatic mode



To sew in Automatic mode:

1. Select the program.
 2. Press the pedal forward and sew.
- ↳ You can see the following on the control panel:

Fig. 58: Sewing in Automatic mode

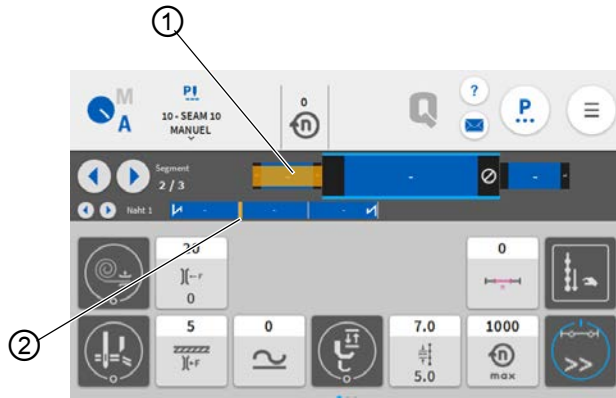

(1) - Progress in the segment (2) - Progress in the program

Possible actions in the course of the seam

The following table lists the functions that can be performed in the course of the seam.

Button/Pedal	Function
	Go to the next or previous step in the seams/ segments
Push the pedal halfway back	Lift sewing foot.
Push the pedal fully back	Cut off or cancel the program. The program remains stopped at the cutoff point.

5.6.2 Canceling a program in Automatic mode



To cancel a program in Automatic mode:

1. Press the pedal fully back.
 - ↳ The program is canceled and the thread cut. The machine takes note of where the program was canceled, and then continues from the same point when sewing resumes.
2. To cancel the program completely, press the pedal all the way backwards again.
 - ↳ The program is canceled, and the machine starts from the first seam section in the program when sewing resumes.



Important

Canceling by pedal is only possible if the parameter segment switch by pedal is NOT active in the program defaults at the Technician level.

If the parameter is still active, you can cancel the program only by pressing the cross on the control panel.

5.7 Using Programming mode



Programming mode allows you to create new programs and copy and adjust existing programs.



To access Programming mode:

1. Press the symbol  to bring up the navigation pane.
 - ↳ This opens the navigation interface.

Fig. 59: Using Programming mode (1)



(1) - Programming mode

2. Press *Programming*.

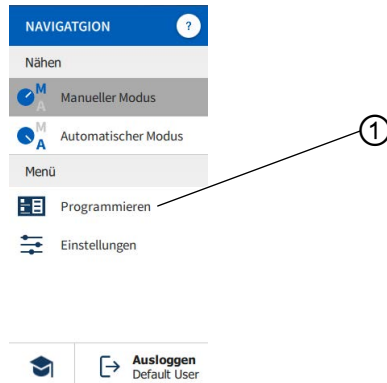
↳ The user interface for Programming mode opens.

Fig. 60: Using Programming mode (2)

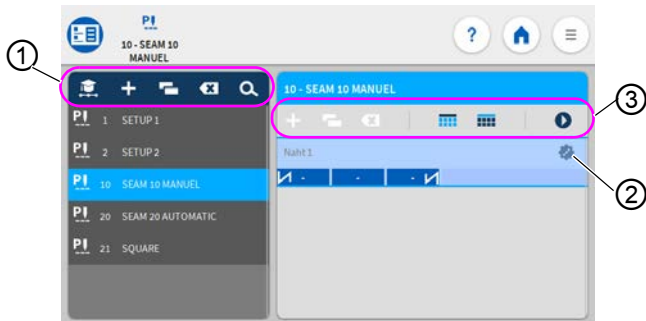





(1) - Manage the programs

(2) - Edit the seams/segments

(3) - Manage the seams/segment



5.7.1 Managing programs





You can create, delete and copy programs. Managing the items is quick and easy thanks to the buttons listed below.

	Let the program learn
	Create a new program
	Copy and insert a program
	Delete a selected program
	Search for a program name

5.7.2 Managing seams

You can create, delete and copy seams. You can also add tiles to the main screen or the status bar. Managing the items is quick and easy thanks to the buttons listed below.

Settings in the selected program (edit seam)	
	Add seam
	Copy and insert a seam
	Delete seam

	Place tiles on the main screen of the program (grid), see  p. 77.
	Place information in the status bar of the program, see  p. 77.
	Exit Programming/Edit and return to the beginning of the program (in Automatic mode)

5.7.3 Editing the segments of a seam

This section allows you to set the parameters for the current seam.



To edit the segments of a seam:

1. Press on the desired seam.
-  The seam is highlighted in blue.

Fig. 61: Editing the segments of a seam (1)



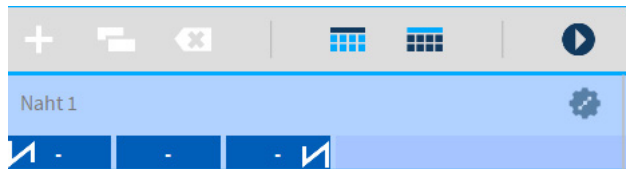

2. Press on the symbol .
-  The interface used for setting the parameters opens:

Fig. 62: Editing the segments of a seam (2)



- (1) - Manage segments
- (2) - Parameters cross-segment
- (3) - Parameters Segment
- (4) - Parameters Segment End/
Seam End
- (5) - Parameters Segment Begin/
Seam Begin
- (6) - List of adjustable parameters

5.7.4 Managing segments

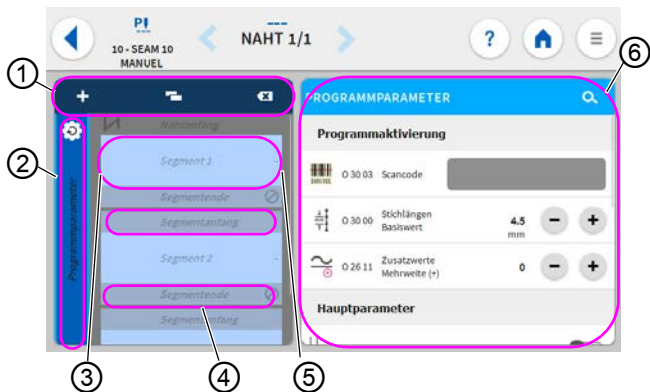





You can create, delete and copy segments. Managing the items is quick and easy thanks to the buttons listed below.





Edit segments	
	Add segment
	Copy and insert a segment
	Delete segment

5.7.5 Setting program parameters

There are various options for setting the cross-program parameters. The following table lists all possible options.

Settings that are more complex and therefore require further explanation are described in more detail after the table.

Icon	Parameter	Setting
Program activation		
	<i>Scan code</i>	
	<i>Stitch length level</i>	Value range 3.0 – 6.0 [mm]
	<i>Additional values fullness</i>	Value range 00 - 31
Main Parameter		
	<i>Needle cooling</i>	Value range On/Off
	<i>Counter Mode</i> Daily piece counter, can be set to count either up or down.	<i>Total/Up/Down</i>
		<i>Reset</i> When the daily piece counter is activated, it must be reset once after entering a value to ensure it counts correctly.
	<i>Flat Sew</i>	Value range 00 - 50
	<i>Mode for ruffing-based tape tension</i>	Value range Off/Switching

Icon	Parameter	Setting
Correction speed effect		
	<i>Correction speed effect</i>	Value range On/Off (see  p. 101)
	<i>Stitch length</i>	The stitch length changes slightly depending on the speed. For this reason, the stitch length can be adjusted at different speeds by the software.
	<i>Needle thread tension</i>	Depending on the speed, the needle thread tension can be adjusted at different speeds by the software.



5.7.5.1 Setting the *Correction speed effect* parameters

Some parameters are affected by high speeds because of the resulting physical effects. To counteract these effects and to achieve consistent results, even at high speeds, adjustment factors can be set depending on the speed.

Overview of setting modes

The correction of the effects of high speeds can be identified in various modes and responded to depending on the setting. This general explanation can be applied to the following specific parameters.

Setting mode	Description
<i>linear</i>	In the linear setting, the size of the parameter increases or decreases steadily as the speed increases. The increase/decrease of the parameter depends on the limits set for the minimum and maximum speed.
<i>2. Value On/Off</i>	If a certain speed is exceeded, the 2 nd value of the parameter is activated. If the speed then falls below this level again, it switches to the base value for the parameter.
<i>2. Value On</i>	If a certain speed is exceeded, the 2 nd value of the parameter is activated. If the speed then falls below this level again, it does NOT switch to the base value for the parameter. Only after finishing the seam by cutting the thread is the base value for the parameter set again.

Setting options *Stitch length*

Menu item	Setting 1	Setting 2
<i>linear</i>	<i>Stitch length</i> Value range -50 – 50 [%]	Maximum stitch length variation reached at the upper speed limit.
	<i>Min. Sewing speed</i> Value range 0000 – 3500 [rpm] (depending on subclass)	Speed at which the increase/reduction of the stitch length should start.
	<i>Max. Sewing speed</i> Value range 0000 – 4000 [rpm] (depending on subclass)	Speed up to which the increase/reduction of the stitch length should occur.
<i>2. Value On/Off</i>	<i>Min. Sewing speed</i> Value range 0000 – 3500 [rpm] (depending on subclass)	Speed from which the 2 nd stitch length should be used.
<i>2. Value</i>	<i>Min. Sewing speed</i> Value range 0000 – 3500 [rpm] (depending on subclass)	Speed from which the 2 nd stitch length should be used.







Setting options *Needle thread tension*

Menu item	Setting 1	Setting 2
<i>linear</i>	<i>Needle thread tension</i> Value range 00 – 99	Maximum needle thread tension reached at the upper speed limit.
	<i>Min. Sewing speed</i> Value range 0000 – 3500 [rpm] (depending on subclass)	Speed at which the increase in needle thread tension should start.
	<i>Max. Sewing speed</i> Value range 0000 – 3500 [rpm] (depending on subclass)	Speed up to which the increase in needle thread tension should occur.
<i>2. Value On/Off</i>	<i>Min. Sewing speed</i> Value range 0000 – 3500 [rpm] (depending on subclass)	Speed from which the 2 nd needle thread tension should be used.
<i>2. Value On</i>	<i>Min. Sewing speed</i> Value range 0000 – 3500 [rpm] (depending on subclass)	Speed from which the 2 nd needle thread tension should be used.

5.7.6 Setting the *Seam Begin/Segment Begin* parameters

There are various options for setting the Seam Begin/Segment Begin parameters. The following table lists all possible options.







Settings that are more complex and therefore require further explanation are described in more detail after the table.







Icon	Parameter	Setting
Settings of stitch condensing at seam beginning		
	<i>Stitch condensing at seam beginning</i>	Value range On/Off
	<i>Number of condensing stitches</i>	Value range 01 - 50
	<i>Factor</i>	Value range 25 - 100 [%]
Seam begin bartack parameters		
	<i>Single stitches per pedal</i> If this function is activated, each stitch in the bartack can be sewn individually by pressing the pedal. This function can only be used meaningfully if the speed is set very low for the bartack.	Value range On/Off
Settings of stitch condensing at seam beginning		
	<i>Needle thread tension default</i> If this function is active, the same needle thread tension is used for the bartack as the one set in Manual mode. If this function is deactivated, a custom input can be entered.	Value range On/Off

5.7.7 Setting the *Segment* parameters

There are various options for setting the parameters in the segment. The following table lists all possible options.

Settings that are more complex and therefore require further explanation are described in more detail after the table.

Icon	Parameter	Setting
Seam Parameter		
	<i>Stitch length</i>	Value range 00.0 - 12.0 [mm] (depending on the sewing equipment and the subclass)
	<i>Needle thread tension</i>	Value range 01 - 99 [%]
	<i>Hook thread tension</i>	Value range 01 - 99 [%]
	<i>Fullness</i>	Value range 00 - 31
	<i>Seam length in segment</i> or <i>Number of stitches in segment</i>	You can set the active option at the Technician level <i>Machine configuration</i> > <i>Seam segment mode</i> . The s.p.m. option is set at the factory. The display remains after the thread has been cut, while counting/measuring will begin when sewing starts again.
	<i>Max. Speed</i> It is possible to reduce the maximum sewing speed at this point. The maximum sewing speed can be set in the software at the Technician level.	Value range 0050 – 3800 [rpm] (depending on subclass)

Icon	Parameter	Setting
	<i>Needle position</i> Position of the needle when sewing stops.	Value range On/Off
	<i>Sewing foot lift at stop</i>	Value range On/Off
	<i>Edge trimmer</i>	Value range On/Off
	<i>Tape tension</i>	Value range On/Off
Output		
	<i>Output 01-16</i>	(see  p. 106)

5.7.7.1 Setting the Outputs (*Output*) parameter





This parameter provides virtual outputs that can be assigned customer-specific functions. They can be used when customer-specific applications require a signal from the control of the machine.



This parameter cannot be used unless the virtual outputs have been assigned to a physical output at the Technician level. This requires that the parameter *Additional I/O Configuration* can be configured at the Technician level; for more details, refer to the explanation in the  *Service Instructions*.

5.7.8 Setting the *Segment End/Seam End* parameters

There are various options for setting the Segment End/Seam End parameters. The following table lists all possible options.

Settings that are more complex and therefore require further explanation are described in more detail after the table.



Icon	Parameter	Setting
Parameters Seam End		
	<i>Sewing stop</i>	Value range On/Off Setting as to what will happen at the end of a segment/seam. (see  p. 108)
Settings of stitch condensing at seam end		
	<i>Stitch condensing at seam end</i>	Value range On/Off
	<i>Number of condensing stitches</i>	Value range 01 - 50
	<i>Factor</i>	Value range 25 - 100 [%]

Icon	Parameter	Setting
Adjustments for seam end bartack parameters		
	<i>Single stitches per pedal</i> If this function is activated, each stitch in the bartack can be sewn individually by pressing the pedal. This function can only be used meaningfully if the speed is set very low for the bartack.	Value range On/Off
Settings of stitch condensing at seam end		
	<i>Needle thread tension default</i> If this function is active, the same needle thread tension is used for the bartack as the one set in Manual mode. If this function is deactivated, a custom input can be entered.	Value range On/Off

5.7.8.1 Setting the *Sewing stop* parameters



You can set additional parameters for the *Sewing stop*. Possible settings and the corresponding value ranges are listed in the table.

Icon	Menu item	Setting option
	<i>Needle up position</i>	Value range On/Off
	<i>Sewing foot lift at segment end</i>	Value range On/Off

5.8 Importing/exporting programs

Programs cannot be imported or exported by the Default User.

This process requires that the user be logged in as a technician,  *Service Instructions*.

5.9 Performing a software update

A software update - for control panel or control - is always performed on the control panel. The software of the control is updated automatically whenever a software update is performed for the control panel. The files necessary for updating the control are already included in the file updates of the control panel.



To perform a software update:

1. Log in as a user with the access rights necessary to perform a software update (see  p. 63 on how to define this setting).
2. Download the software version from the Internet (www.duerkopp-adler.com) and save it to a USB key.
3. Plug the USB key into the port on the control panel.
4. Open the burger menu and select the menu *Settings - Software Update*.
 - ↳ A window listing the files stored on the USB key opens.
5. Select the file containing the software update.
 - ↳ Another window opens.
6. To start the software update, press on the *Start Update* button.
7. Wait until advised that the USB key can be removed OR that the control panel was restarted.



Information

If detecting - while the control panel is being restarted - that the software of the control requires an update as well, the system will start this update automatically.

It may take up to 15 minutes for the system to complete the update and restart the control panel successfully.

8. Once the control panel has been restarted, the machine can be used again.
9. If you have not already done so, you can now remove the USB key.

6 Maintenance

WARNING



Risk of injury from sharp parts!

Punctures and cutting possible.

Prior to any maintenance work, switch off the machine or set the machine to threading mode.

WARNING



Risk of injury from moving parts!

Crushing possible.

Prior to any maintenance work, switch off the machine or set the machine to threading mode.

This chapter describes maintenance work that needs to be carried out on a regular basis to extend the service life of the machine and achieve the desired seam quality.

Advanced maintenance work may only be carried out by qualified specialists ( *Service Instructions*).

6.1 Maintenance intervals

Work to be carried out	Operating hours			
	8	40	160	500
Machine head				
Removing lint and thread remnants	●			
Clean the area under the throat plate	●			
Check oil level at machine head	●			
Check oil level at hook drive housing		●		
Pneumatic system				
Check the operating pressure	●			
Check the water level in the pressure controller	●			
Clean the filter element in the compressed air maintenance unit				●
Check the tightness of the system				●

6.2 Cleaning

WARNING



Risk of injury from flying particles!

Flying particles can enter the eyes, causing injury.

Wear safety goggles.

Hold the compressed air gun so that the particles do not fly close to people.

Make sure no particles fly into the oil pan.

NOTICE

Property damage from soiling!

Lint and thread remnants can impair the operation of the machine.

Clean the machine as described.

NOTICE

Property damage from solvent-based cleaners!

Solvent-based cleaners will damage paintwork.

Use only solvent-free substances for cleaning.

Fig. 63: Cleaning

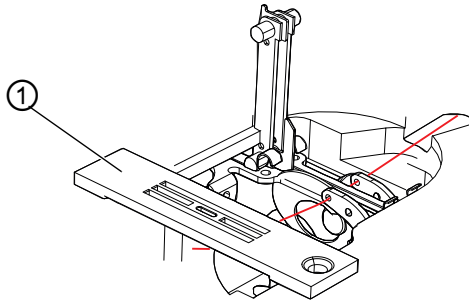

(1) - Throat plate



To clean the machine:

1. Remove any lint and thread remnants using a compressed air gun or a brush, particularly from the area of the throat plate (1) and the thread channel.
2. Remove sewing dust and cutting waste from the oil pan.

6.3 Lubricating

CAUTION



Risk of injury from contact with oil!

Oil can cause a rash if it comes into contact with skin.

Avoid skin contact with oil.

If oil has come into contact with your skin, wash the affected areas thoroughly.

NOTICE

Property damage from incorrect oil!

Incorrect oil types can result in damage to the machine.

Only use oil that complies with the data in the instructions.

CAUTION



Risk of environmental damage from oil!

Oil is a pollutant and must not enter the sewage system or the soil.

Carefully collect up used oil.

Dispose of used oil and oily machine parts in accordance with national regulations.

The machine must be lubricated at regular intervals ( p. 112). Complete the following steps when lubricating the machine:

- Checking the oil level
- Lubricating the machine head
- Lubricating the hook

For topping off the oil reservoir, use only lubricating oil **DA 10** or oil of equivalent quality with the following specifications:

- Viscosity at 40 °C: 10 mm²/s
- Flash point: 150 °C

You can order the lubricating oil from our sales offices using the following part numbers

Container	Part no.
250 ml	9047 000011
1 l	9047 000012
2 l	9047 000013
5 l	9047 000014

6.3.1 Checking the lubrication of the machine head

NOTICE

Property damage from incorrect oil level!

Too little or too much oil can cause damage the machine.
Top off oil as described.

NOTICE

Property damage from incorrect oil!

Incorrect oil types can result in damage to the machine.
Use only oil that corresponds to the following specifications.

Fig. 64: Checking the lubrication of the machine head



(1) - Minimum level marking
(2) - Maximum level marking

(3) - Filler opening

Checking the oil level



Proper setting

The oil level must always be between the minimum level marking (1) and the maximum level marking (2) at the inspection glass.

Topping off the oil reservoir



To top off the oil reservoir:

1. Fill oil through the filler hole (3) to a maximum of 2 mm below the maximum level marking (2).

6.3.2 Checking the hook lubrication

NOTICE

Property damage from incorrect oil level!

Too little or too much oil can cause damage the machine.

Top off oil as described.

Fig. 65: Checking the hook lubrication (1)

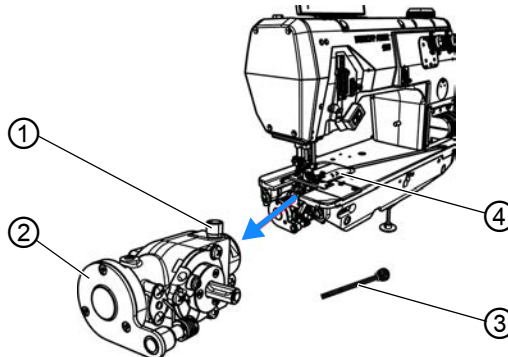

(1) - Screw plug

(2) - Hook drive housing

(3) - Dipstick

(4) - Right hook cover

Hook drive housing (2) and screw plug (1) can be accessed under the right hook cover (4).

Fig. 66: Checking the hook lubrication (2)

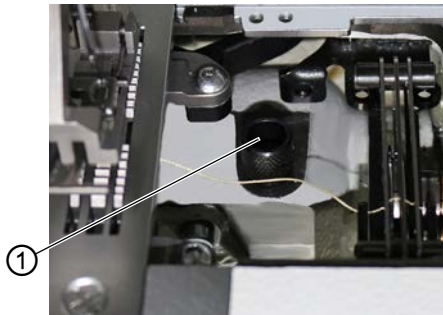

(1) - Screw plug

Checking the oil level

To measure the oil level, you will need the dipstick (3) included in the accessory pack.



To check the oil level:

1. Keep the dipstick (3) ready.
2. Open the right hook cover.
3. Loosen the screw plug (1) on the filler opening.
4. Insert the dipstick (3) into the hook drive housing (2).
5. After a few seconds, pull the dipstick (3) out of the hook drive housing (2).

Fig. 67: Checking the hook lubrication (3)



(5) - Minimum level marking

(6) - Maximum level marking

6. Check if the oil level is between the minimum level marking (4) and the maximum level marking (5).
7. Tighten the screw plug (1) if the oil level is sufficient.
8. Top off the oil if the oil level is low.



Topping off the oil



To top off the oil in the hook drive housing:

1. Loosen the screw plug (1) on the filler opening.



Important

Only top off the oil a little at a time. When finished, check the oil level. If necessary, repeat these 2 steps several times until the oil level is just below the maximum level marking (5) of the dipstick (3). There must not be too much oil in the hook drive housing.

2. Carefully refill oil through the filler opening no higher than the maximum level marking (5) of the dipstick (3).
3. Check the oil level again.
4. If necessary, repeat step 2 and 3 until the oil level is just below the maximum level marking (5) of the dipstick (3).
5. Tighten the screw plug (1).

6.4 Servicing the pneumatic system

6.4.1 Setting the operating pressure

NOTICE

Property damage from incorrect setting!

Incorrect operating pressure can result in damage to the machine.

Ensure that the machine is only used when the operating pressure is set correctly.



Proper setting

Refer to the **Technical data** (📖 p. 173) chapter for the permissible operating pressure. The operating pressure cannot deviate by more than ± 0.5 bar.

Check the operating pressure on a daily basis.

Fig. 68: Setting the operating pressure

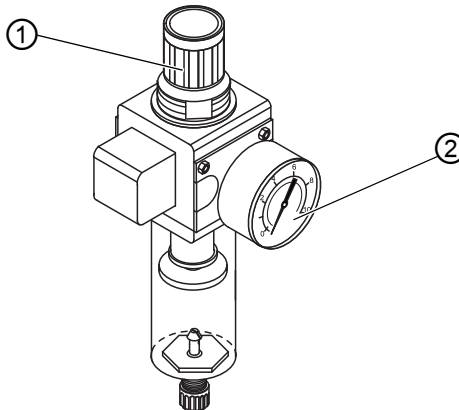

(1) - Pressure controller

(2) - Pressure gage

To set the operating pressure:



1. Pull the pressure controller (1) up.

2. Turn the pressure controller until the pressure gage (2) indicates the proper setting:
 - Increase pressure = turn clockwise
 - Reduce pressure = turn counterclockwise
3. Push the pressure controller (1) down.

6.4.2 Draining the water condensation

NOTICE

Property damage from excess water!

Excess water can cause damage to the machine.

Drain water as required.

Water condensation accumulates in the water separator (2) of the pressure controller.



Proper setting

Water condensation must not rise up to the level of the filter element (1).

Check the water level in the water separator (2) on a daily basis.

Fig. 69: Draining the water condensation

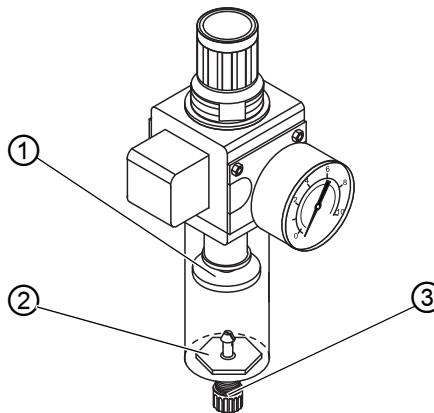

(1) - Filter element
(2) - Water separator

(3) - Drain screw

To drain water condensation:



1. Disconnect the machine from the compressed air supply.
2. Place the collection tray under the drain screw (3).
3. Loosen the drain screw (3) completely.
4. Allow water to drain into the collection tray.
5. Tighten the drain screw (3).
6. Connect the machine to the compressed air supply.

6.4.3 Cleaning the filter element

NOTICE

Damage to the paintwork from solvent-based cleaners!

Solvent-based cleaners damage the filter.

Use only solvent-free substances for washing out the filter tray.

Fig. 70: Cleaning the filter element

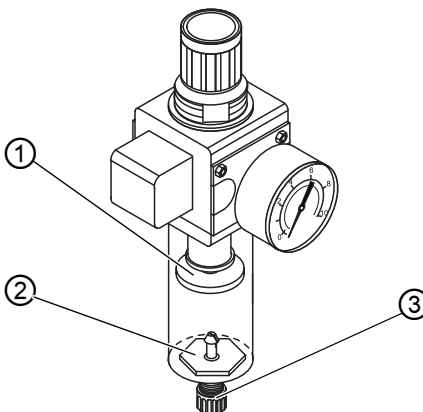

(1) - Filter element
(2) - Water separator

(3) - Drain screw

To clean the filter element:



1. Disconnect the machine from the compressed air supply.
2. Drain the water condensation ( p. 121).
3. Loosen the water separator (2).
4. Loosen the filter element (1).
5. Blow out the filter element (1) using the compressed air gun.
6. Wash out the filter tray using benzine.
7. Tighten the filter element (1).
8. Tighten the water separator (2).
9. Tighten the drain screw (3).
10. Connect the machine to the compressed air supply.

6.5 Parts list

A parts list can be ordered from Dürkopp Adler. Or visit our website for further information at:

www.duerkopp-adler.com



7 Setup

WARNING



Risk of injury from cutting parts!

Cutting injuries may be sustained while unpacking and setting up the machine.

Only qualified specialists may set up the machine.
Wear safety gloves.

WARNING



Risk of injury from moving parts!

Crushing injuries may be sustained while unpacking and setting up the machine.

Only qualified specialists may set up the machine.
Wear safety shoes.

7.1 Checking the scope of delivery

The scope of delivery depends on your specific order. Check that the scope of delivery is correct after taking delivery.

7.2 Removing the transport locks

Remove all transport locks before setting up the machine:

- Lashing straps and wooden blocks from the machine head
- If applicable, safety clips on the stand feet
- All pieces of Styrofoam and cardboard
- If applicable, lashing straps and wooden blocks from the table-top and the stand

7.3 Assembling the reel stand

A fully assembled reel stand is included and must be assembled to the tabletop.

Fig. 71: Assembling the reel stand (1)



(1) - Washer
(2) - Nut

(3) - Reel stand tube



To assemble the reel stand:

1. Place a washer (1) onto the hole in the tabletop.
2. Screw in a nut (2) until you reach the end of the thread.
3. Insert the reel stand tube (3) through the washer (1) and into the hole in the tabletop.

Fig. 72: Assembling the reel stand (2)

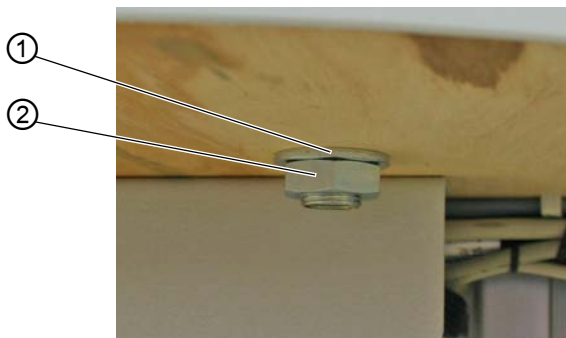

(1) - Washer

(2) - Nut

- Slide the 2nd washer (1) from the bottom onto the thread at the end of the reel stand tube (3).
 - Screw the 2nd nut (2) from the bottom onto the thread at the end of the reel stand tube (3).
- 👉 The reel stand is now securely assembled to the tabletop.



Important

The unwinding bracket (4) must stand directly above the thread reels (5).

Fig. 73: Assembling the reel stand (3)

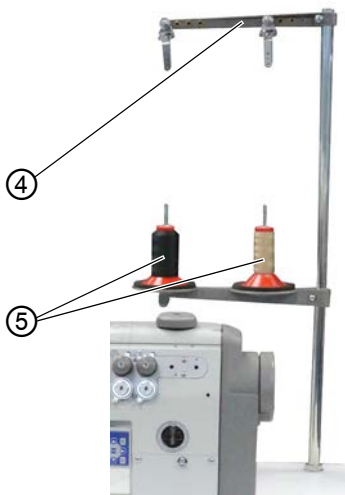

(4) - Unwinding bracket

(5) - Thread reel

7.4 Setting the working height

WARNING



Risk of injury from moving parts!

The tabletop can sink under its own weight when the screws on the stand bars are loosened. Crushing possible.

Ensure that your hands are not jammed when loosening the screws.

CAUTION



Risk of musculoskeletal damage from incorrect setting!

The operator can sustain musculoskeletal damage if failing to comply with the ergonomic requirements.

Adjust the working height to the body height of the person who will operate the machine.

The working height can be adjusted between 750 mm and 950 mm (measured to the upper edge of the tabletop).

Fig. 74: Setting the working height

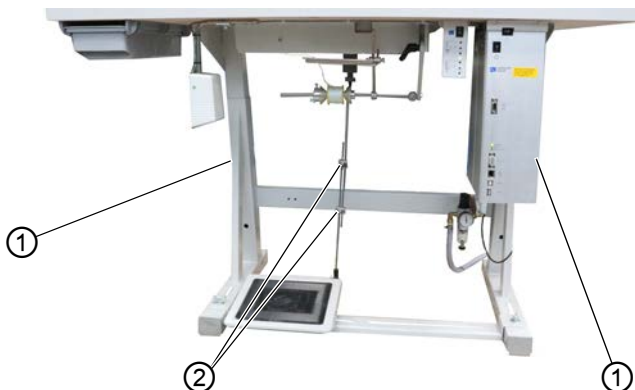

(1) - Screw (not visible)

(2) - Screw



To set the working height:

1. Loosen the 2 screws (2) on the pedal rod.
2. Loosen the screw (1) on both bars of the stand.
We recommend to seek the assistance of a 2nd person to complete this step.
3. To avoid jamming, slide the tabletop in or out evenly at both sides.
The scales on the outer sides of the stand bars serve as an adjustment aid.
4. Tighten the screw (1) on both bars of the stand.
5. Ensure that the setting of the pedal rod matches the new working height.
6. Tighten both screws (2) on the pedal rod.
7. Set the pedal again ( p. 130).

7.5 Setting the pedal

CAUTION



Risk of injury!

Crushing possible.

Take care not to crush your fingers at the pedal rod or the pedal.

Fig. 75: Setting the pedal

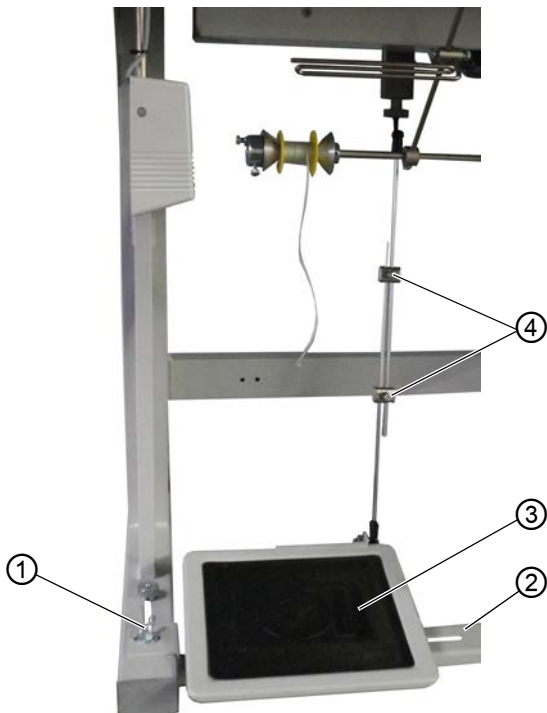

(1) - Wing nut
(2) - Cross strut

(3) - Pedal
(4) - Screw

**Proper setting:** 10° inclination with pedal (3) released

The pedal (3) is assembled to the cross strut (2). You can adjust the position of the pedal (3) as needed by moving it using the cross strut.

The pedal (3) must also be tilted to a degree that allows the operator to move the pedal forward and backward without a problem.



To set the position of the pedal:

1. Loosen the wing nuts (1) on the left and the right of the cross strut ends (2).
2. Slide the cross strut (2) that holds the pedal (3) forward or backward.
3. Tighten the wing nuts (1) on the left and the right of the cross strut ends (2).
4. Slightly loosen the 2 screws (4) on the pedal rod.

Fig. 76: Setting the pedal (2)

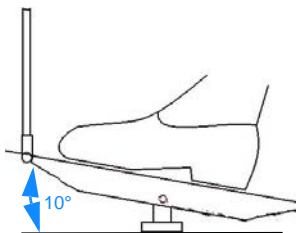

5. Pull the pedal rod to the correct length.
 - ↳ When in the rest position, the pedal (3) must be bent 10° at the front.
6. Tighten the 2 screws (4) on the pedal rod.

7.6 Inserting the machine head

WARNING



Risk of crushing from moving parts.

The machine head is very heavy.
Crushing possible.

Ensure that your hands are not jammed when
inserting the machine head.

NOTICE

Property damage may occur!

Cable may sustain damage and impair the operation of the
machine.

Always lay the cables so as not to create any chafing or
pinching points.

Fig. 77: Inserting the machine head

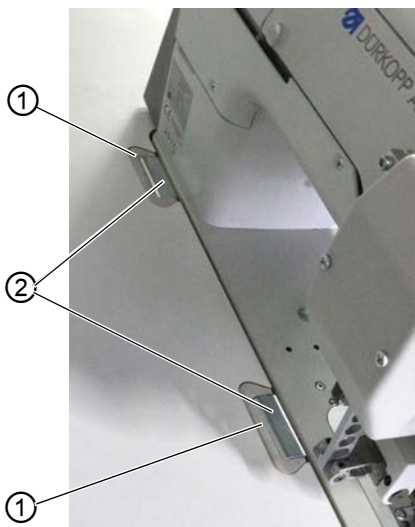

(1) - Lower hinge part

(2) - Hinge



To insert the machine head (2):

1. Guide the cables through the tabletop with great care so as not to kink or pinch them.
2. Insert the machine head vertically into the tabletop cutout.
3. Insert the hinges (2) into the lower hinge parts (1).

7.7 Tilting and erecting the machine head

WARNING



Risk of injury from electricity!

Parts of the machine may be energized.

Switch off the machine and disconnect the power plug.

You can tilt the machine head for maintenance work.

Fig. 78: Tilting and erecting the machine head



(1) - Tilt protection device

Tilting the machine head



To tilt the machine head:

1. Grab the machine head at the top on the machine arm and carefully lower it down to the tilt protection device (1).
- ⚠ The tilt sensor locks the machine for as long as the machine head is tilted. Sewing is not possible during this time.

Erecting the machine head



To erect the machine head:

1. Grab the machine at the machine arm and erect it carefully.
 - ↳ The tilt sensor detects the erected position and unlocks the machine. The machine is ready to sew again.
-



Information

The tilt sensor is composed of the tilt sensor found on the machine head and a permanent magnet housed inside the tabletop cutout. Both parts have been pre-assembled at the factory.

The machine remains locked if the tilt sensor is not fully assembled or defective.

7.8 Electrical connection

DANGER



Risk of death from live components!

Unprotected contact with electricity can result in serious injuries or death.

Only qualified specialists may perform work on electrical equipment.



Important

The voltage on the type plate of the sewing motor must correspond to the mains voltage.

7.9 Establishing equipotential bonding



Important

Before putting the machine into operation, establish equipotential bonding.



To establish equipotential bonding:

1. Establish equipotential bonding as specified in the wiring diagram ( p. 175).

7.10 Pneumatic connection

NOTICE

Property damage from oily compressed air!

Oil particles in the compressed air can cause malfunctions of the machine and soil the sewing material.

Ensure that no oil particles enter the compressed air supply.

NOTICE

Property damage from incorrect setting!

Incorrect system pressure can result in damage to the machine.

Ensure that the machine is only used when the system pressure is set correctly.

The pneumatic system of the machine and of the additional equipment must be supplied with dry and oil-free compressed air. The supply pressure must lie between 8 and 10 bar.

7.10.1 Assembling the compressed air maintenance unit

To assemble the compressed air maintenance unit:



1. Connect the connection hose to the compressed air supply using a hose coupling R 1/4".

7.10.2 Setting the operating pressure

NOTICE

Property damage from incorrect setting!

Incorrect operating pressure can result in damage to the machine.

Ensure that the machine is only used when the operating pressure is set correctly.



Proper setting

Refer to the **Technical data** (📖 p. 173) chapter for the permissible operating pressure. The operating pressure cannot deviate by more than ± 0.5 bar.

Fig. 79: Setting the operating pressure

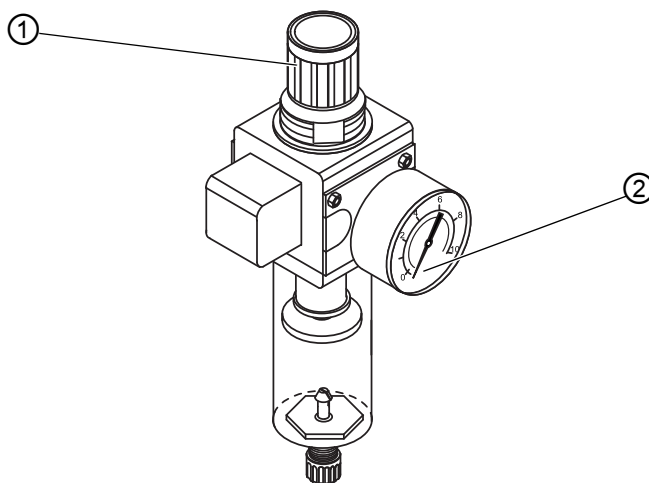

(1) - Pressure controller

(2) - Pressure gage

To set the operating pressure:



1. Pull the pressure controller (1) up.
2. Turn the pressure controller until the pressure gage (2) indicates the proper setting:
 - Increase pressure = turn clockwise
 - Reduce pressure = turn counterclockwise
3. Push the pressure controller (1) down.

7.11 Lubricating

Required oil:

CAUTION



Risk of environmental damage from oil!

Oil is a pollutant and must not enter the sewage system or the soil.

Collect waste oil carefully and dispose of it and oily machine parts in accordance with the applicable statutory regulations.

NOTICE

Machine damage possible due to incorrect oil!

An incorrect oil type can cause damage to the machine.

Only use oil specified in the operating instructions.

NOTICE

Property damage from incorrect oil level!

Too little or too much oil can cause damage the machine.

Top off oil as described.

Only DA 10 or equivalent oil should be used for the machine, which has the following properties:

- Viscosity at 40 °C: 10 mm²/s
- Flash point: 150 °C

Fig. 80: Lubricating

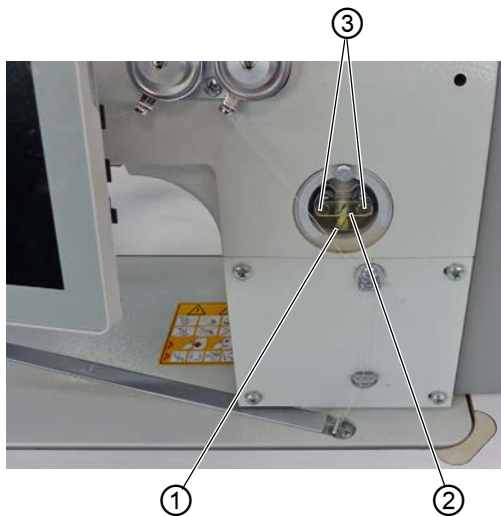

(1) - Minimum level marking
(2) - Maximum level marking

(3) - Filler opening

All wicks and felt bits of the machine head are soaked in oil at the factory. This oil is conveyed to the reservoir during use. This is why you should avoid filling too much oil during initial filling.

Checking the oil level



Proper setting

The oil level must always be between the minimum level marking (1) and the maximum level marking (2).

Topping off the oil reservoir



To top off the oil reservoir:

1. Fill oil through the filler hole (3) to a maximum of 2 mm below the maximum level marking (2).

7.12 Performing a test run

WARNING



Risk of injury from moving, cutting and sharp parts!

Crushing, cutting and punctures are possible.









Switch off the machine before you replace the needle, insert the thread, and adjust the needle/hook thread tension and the thread regulator.

When setup is complete, perform a test run to check the functionality of the machine.

Adjust the machine to the sewing material requirements.



To perform a test run:

1. Insert needle ( p. 22).
2. Thread hook thread ( p. 27).
3. Thread needle thread ( p. 24).
4. Set the thread tension to the sewing material being sewn ( p. 37).
5. Set the needle thread regulator to the sewing material being sewn ( p. 38).
6. Set the sewing foot pressure to the sewing material being sewn ( p. 50).
7. Set the sewing foot stroke to the sewing material being sewn ( p. 49).
8. Set stitch length ( p. 55).
9. Switch on the machine ( p. 20).
10. Start a sewing test with the appropriate sewing material and at a low speed.

Gradually increase the speed until the working speed is reached.

8 Decommissioning

WARNING



Risk of injury from a lack of care!

Serious injuries may occur.

ONLY clean the machine when it is switched off.
Allow ONLY trained personnel to disconnect the machine.

CAUTION



Risk of injury from contact with oil!

Oil can cause a rash if it comes into contact with skin.

Avoid skin contact with oil.

If oil has come into contact with your skin, wash the affected areas thoroughly.

To decommission the machine:



1. Switch off the machine.
2. Unplug the power plug.
3. If applicable, disconnect the machine from the compressed air supply.
4. Remove residual oil from the oil pan using a cloth.
5. Cover the control panel to protect it from soiling.
6. Cover the control to protect it from soiling.
7. Cover the entire machine if possible to protect it from contamination and damage.

9 Disposal

CAUTION



Risk of environmental damage from improper disposal!

Improper disposal of the machine can result in serious environmental damage.

ALWAYS comply with the national regulations regarding disposal.

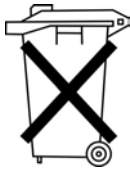

The machine must not be disposed of in the normal household waste.

The machine must be disposed of in a suitable manner in accordance with all applicable national regulations.

When disposing of the machine, be aware that it consists of a range of different materials (steel, plastic, electronic components, etc.). Follow the national regulations when disposing these materials.

10 Troubleshooting

10.1 Customer Service

Contact for repairs and issues with the machine:

Dürkopp Adler GmbH

Potsdamer Str. 190
33719 Bielefeld, Germany

Tel. +49 (0) 180 5 383 756

Fax +49 (0) 521 925 2594

Email: service@duerkopp-adler.com

Internet: www.duerkopp-adler.com



10.2 Messages of the software

Please contact customer service if an error occurs that is not described here. Do not attempt to correct the error yourself.

Messages of the software

Code	Type	Possible cause	Remedial action
1000	Error	Sewing motor encoder plug (Sub-D, 9-pin) not connected	<ul style="list-style-type: none"> • Connect encoder cable to the control, • use correct connection
1001	Error	Sewing motor error Sewing motor plug (AMP) not connected	<ul style="list-style-type: none"> • Check connection and plug in • Test sewing motor phases ($R = 2.8\Omega$, high impedance to PE) • Replace encoder • Replace sewing motor • Replace control
1002	Error	Sewing motor insulation error	<ul style="list-style-type: none"> • Check motor phase and PE for low-impedance connection • Replace encoder • Replace sewing motor
1004	Error	Incorrect sewing motor direction of rotation	<ul style="list-style-type: none"> • Replace encoder • Check motor plug assignment and change it if necessary • Check wiring in machine distributor and change it, if necessary • Test motor phases and check for correct value
1005	Error	Motor blocked	<ul style="list-style-type: none"> • Eliminate stiff movement in the machine • Replace encoder • Replace sewing motor
1006	Error	Maximum speed exceeded	<ul style="list-style-type: none"> • Replace encoder • Perform reset • Check class (t 51 04)
1007	Error	Error in the reference run	<ul style="list-style-type: none"> • Replace encoder • Eliminate stiff movement in the machine
1008	Error	Sewing motor encoder error	<ul style="list-style-type: none"> • Replace encoder
1010	Error	External synchronizer plug (Sub-D, 9-pin) not connected	<ul style="list-style-type: none"> • Connect cable of external synchronizer to control, make sure that interface (Sync) is correct • Only recommended for machines with transmission!

Code	Type	Possible cause	Remedial action
1011	Error	Encoder Z pulse missing	<ul style="list-style-type: none"> • Switch off the control, use handwheel to turn, and switch on the control again • If error is not corrected, check encoder
1012	Error	Synchronizer fault	<ul style="list-style-type: none"> • Replace synchronizer
1051	Error	Sewing motor timeout: • Cable to sewing motor Reference switch defective • Reference switch defective	<ul style="list-style-type: none"> • Replace cable • Replace reference switch
1052	Error	Sewing motor overcurrent: • Sewing motor cable defective • Sewing motor defective • Control defective	<ul style="list-style-type: none"> • Replace sewing motor cable • Replace sewing motor • Replace control
1053	Error	Sewing motor overvoltage	<ul style="list-style-type: none"> • Check mains voltage
1054	Error	Internal short circuit	<ul style="list-style-type: none"> • Replace control
1055	Error	Sewing motor overload	<ul style="list-style-type: none"> • Eliminate stiff movement in the machine • Replace encoder • Replace sewing motor
1056	Error	Sewing motor overtemperature: • Sewing motor not moving freely • Sewing motor defective • Control defective	<ul style="list-style-type: none"> • Eliminate sluggishness • Replace sewing motor • Replace control
1058	Error	Sewing motor speed greater than setpoint: • Reference switch defective • Sewing motor defective	<ul style="list-style-type: none"> • Replace reference switch • Replace sewing motor
1060	Error	Sewing motor overload / overvoltage /overcurrent	<ul style="list-style-type: none"> • Check selection of class • Replace control • Replace motor • Replace encoder
1061	Error	Sewing motor overload / overvoltage /overcurrent	<ul style="list-style-type: none"> • Check selection of class • Replace control • Replace motor • Replace encoder

Code	Type	Possible cause	Remedial action
1062	Error	Sewing motor disturbance (IDMA auto increment)	<ul style="list-style-type: none"> • Switch off and on the machine
1120	Error	Sewing motor Init fault	<ul style="list-style-type: none"> • Perform software update • Check selection of class
1121	Error	Sewing motor watchdog	<ul style="list-style-type: none"> • Perform software update • Check selection of class
1203	Error	Position not reached (during thread cutting, reversal, etc.)	<ul style="list-style-type: none"> • Check the controller settings and change them if necessary (e.g. thread trimmer setting, belt tension, etc.) • Check position thread lever at top dead center
1302	Error	Failure with sewing motor current	<ul style="list-style-type: none"> • Check Service Stop • Eliminate stiff movement in the machine • Replace encoder • Replace motor
1330	Error	No response from sewing motor	<ul style="list-style-type: none"> • Perform software update • Replace control
2101	Error	Stepper motor X30 reference run timeout	<ul style="list-style-type: none"> • Check reference sensor
2102	Error	X-axis stepper motor: <ul style="list-style-type: none"> • Stepper motor not moving freely or blocked • Encoder cable not connected or defective • Stepper motor cable is not connected or faulty • Encoder defective • Stepper motor faulty 	<ul style="list-style-type: none"> • Remove the cause of the stiff movement or blockage • Check the encoder cable and replace, if necessary • Replace encoder If the stepper motor is not supplied with current: <ul style="list-style-type: none"> • Check the stepper motor cable and replace, if necessary • Replace stepper motor
2103	Error	X-axis stepper motor step losses: <ul style="list-style-type: none"> • Stiff mechanical movement or blockage 	<ul style="list-style-type: none"> • Remove the cause of the stiff mechanical movement or blockage
2105	Error	Stepper motor card X30 blockage	<ul style="list-style-type: none"> • Eliminate stiff movement in the machine

Code	Type	Possible cause	Remedial action
2121	Error	Stepper motor card X30 encoder plug (Sub-D, 9-pin) not connected	<ul style="list-style-type: none"> • Connect encoder cable to the control, use the correct interface
2122	Error	Stepper motor card X30 rotor position not found	<ul style="list-style-type: none"> • Check stepper motor 1 for stiff movement
2130	Error	Stepper motor card X30 not responding	<ul style="list-style-type: none"> • Perform software update • Replace control
2131	Error	Stepper motor card X30 parameter init error	<ul style="list-style-type: none"> • Perform software update • Check selection of class
2152	Error	Stepper motor card X30 overcurrent	<ul style="list-style-type: none"> • Eliminate stiff movement in the machine
2153	Error	Overvoltage	<ul style="list-style-type: none"> • Check mains voltage
2155	Error	X-axis stepper motor overload (I ² T): <ul style="list-style-type: none"> • Stepper motor not moving freely or blocked • Stepper motor faulty • Control defective 	<ul style="list-style-type: none"> • Remove the blockage or the cause of the stiff movement • Replace stepper motor • Replace control
2156	Error	X-axis stepper motor: <ul style="list-style-type: none"> • Stepper motor sluggish • Stepper motor faulty • Control defective 	<ul style="list-style-type: none"> • Eliminate sluggishness • Replace stepper motor • Replace control
2162	Error	X-axis stepper motor disturbance (IDMA auto increment)	<ul style="list-style-type: none"> • Switch off and on the machine
2171	Error	Stepper motor card X30 Watchdog (Stitch length)	<ul style="list-style-type: none"> • Perform software update • Check selection of class
2172	Error	Stepper motor card X30 motor overload / overvoltage / overcurrent (Stitch length)	<ul style="list-style-type: none"> • Check selection of class • Replace control • Replace encoder • Replace stepper motor
2173	Error	Stepper motor card X30 Sewing motor encoder not connected (Stitch length)	<ul style="list-style-type: none"> • Replace control

Code	Type	Possible cause	Remedial action
2174	Error	Stepper motor card X30 Sewing motor encoder not init (Stitch length)	<ul style="list-style-type: none"> • Perform software update • Check selection of class
2175	Error	Stepper motor card X30 Init Position not found (Stitch length)	<ul style="list-style-type: none"> • Eliminate stiff movement in the machine • Replace encoder • Replace motor
2176	Error	Stepper motor card X30 not Enabled (Stitch length)	<ul style="list-style-type: none"> • Replace control
2177	Error	Stepper motor card X30 Overload (Stitch length)	<ul style="list-style-type: none"> • Eliminate stiff movement in the machine • Replace encoder • Replace motor
2178	Error	Stepper motor card X30 Encoder failure (Stitch length)	<ul style="list-style-type: none"> • Replace encoder
2179	Error	Stepper motor card X30 Current sensor failure (Stitch length)	<ul style="list-style-type: none"> • Replace control
2180	Error	Stepper motor card X30 Incorrect stepper motor direction of rotation (Stitch length)	<ul style="list-style-type: none"> • Replace encoder • Check if plugs have been mixed up • Check the wiring in the machine distributor and change it if necessary
2181	Error	Stepper motor card X30 Reference run failure (Stitch length)	<ul style="list-style-type: none"> • Eliminate stiff movement in the machine • Replace encoder • Replace motor
2182	Error	Stepper motor current error	<ul style="list-style-type: none"> • Remove blockage • Check the encoder cable and replace, if necessary • Replace stepper motor
2183	Error	Stepper motor card X30 overcurrent (Stitch length)	<ul style="list-style-type: none"> • Replace control
2184	Error	Stepper motor card X30 parameter init (Stitch length)	<ul style="list-style-type: none"> • Perform software update • Check selection of class
2185	Error	Stepper motor card X30 insulation error (Stitch length)	<ul style="list-style-type: none"> • Check motor phase and PE for low-impedance connection • Replace encoder • Replace sewing motor

Code	Type	Possible cause	Remedial action
2186	Error	Software error	<ul style="list-style-type: none"> • Perform reset • Perform software update • Contact customer service
2187	Error	Stepper motor card X30 transport interval failure (Stitch length)	<ul style="list-style-type: none"> • Perform software update • Check selection of class
2188	Error	Stepper motor card X30 Reference run failure (Stitch length)	<ul style="list-style-type: none"> • Eliminate stiff movement in the machine • Replace encoder • Replace motor
2201	Error	Stepper motor X40 reference run timeout	<ul style="list-style-type: none"> • Check reference sensor
2202	Error	Y-axis stepper motor: <ul style="list-style-type: none"> • Stepper motor not moving freely or blocked • Encoder cable not connected or defective • Stepper motor cable is not connected or faulty • Encoder defective • Stepper motor faulty 	<ul style="list-style-type: none"> • Remove the cause of the stiff movement or blockage • Check the encoder cable and replace, if necessary • Replace encoder If the stepper motor is not supplied with current: <ul style="list-style-type: none"> • Check the stepper motor cable and replace, if necessary • Replace stepper motor
2203	Error	Y-axis stepper motor step losses: <ul style="list-style-type: none"> • Stiff mechanical movement or blockage 	<ul style="list-style-type: none"> • Remove the cause of the stiff mechanical movement or blockage
2205	Error	Stepper motor card X40 stepper motor blockage	<ul style="list-style-type: none"> • Eliminate stiff movement in the machine
2221	Error	Stepper motor card X40 encoder plug (Sub-D, 9-pin) not connected	<ul style="list-style-type: none"> • Connect encoder cable to the control, use the correct interface
2222	Error	Stepper motor card X40 rotor position not found	<ul style="list-style-type: none"> • Check stepper motor 1 for stiff movement
2230	Error	Stepper motor card X40 not responding	<ul style="list-style-type: none"> • Perform software update • Replace control
2231	Error	Stepper motor card X40 parameter init error	<ul style="list-style-type: none"> • Perform software update • Check selection of class

Code	Type	Possible cause	Remedial action
2252	Error	Stepper motor card X40 overcurrent	<ul style="list-style-type: none"> • Eliminate stiff movement in the machine
2253	Error	Overvoltage	<ul style="list-style-type: none"> • Check mains voltage
2255	Error	Y-axis stepper motor overload (I ² T): <ul style="list-style-type: none"> • Stepper motor not moving freely or blocked • Stepper motor faulty • Control defective 	<ul style="list-style-type: none"> • Remove the blockage or the cause of the stiff movement • Replace stepper motor • Replace control
2256	Error	Y-axis stepper motor: <ul style="list-style-type: none"> • Stepper motor sluggish • Stepper motor faulty • Control defective 	<ul style="list-style-type: none"> • Eliminate sluggishness • Replace stepper motor • Replace control
2262	Error	Y-axis stepper motor disturbance (IDMA auto increment)	<ul style="list-style-type: none"> • Switch off and on the machine
2271	Error	Stepper motor card X40 Watchdog (sewing foot lift)	<ul style="list-style-type: none"> • Perform software update • Check selection of class
2272	Error	Stepper motor card X40 motor overload / overvoltage /overcurrent (Sewing foot lift)	<ul style="list-style-type: none"> • Check selection of class • Replace control • Replace encoder • Replace stepper motor
2273	Error	Stepper motor card X40 Sewing motor encoder not connected (Sewing foot lift)	<ul style="list-style-type: none"> • Replace control
2274	Error	Stepper motor card X40 Sewing motor encoder not init (Sewing foot lift)	<ul style="list-style-type: none"> • Perform software update • Check selection of class
2275	Error	Stepper motor card X40 Init Position not found (Sewing foot lift)	<ul style="list-style-type: none"> • Eliminate stiff movement in the machine • Replace encoder • Replace motor
2276	Error	Stepper motor card X40 not Enabled (Sewing foot lift)	<ul style="list-style-type: none"> • Replace control

Code	Type	Possible cause	Remedial action
2277	Error	Stepper motor card X40 I²t (Sewing foot lift)	<ul style="list-style-type: none"> • Eliminate stiff movement in the machine • Replace encoder • Replace motor
2278	Error	Stepper motor card X40 Encoder failure (Sewing foot lift)	<ul style="list-style-type: none"> • Replace encoder
2279	Error	Stepper motor card X40 Current sensor failure (Sewing foot lift)	<ul style="list-style-type: none"> • Replace control
2280	Error	Stepper motor card X40 Incorrect stepper motor direction of rotation (Sewing foot lift)	<ul style="list-style-type: none"> • Replace encoder • Check if plugs have been mixed up • Check the wiring in the machine distributor and change it if necessary
2281	Error	Stepper motor card X40 Reference run failure (Sewing foot lift)	<ul style="list-style-type: none"> • Eliminate stiff movement in the machine • Replace encoder • Replace motor
2282	Error	Stepper motor current error	<ul style="list-style-type: none"> • Remove blockage • Check the encoder cable and replace, if necessary • Replace stepper motor
2283	Error	Stepper motor card X40 overcurrent (Sewing foot lift)	<ul style="list-style-type: none"> • Replace control
2284	Error	Stepper motor card X40 parameter init (Sewing foot lift)	<ul style="list-style-type: none"> • Perform software update • Check selection of class
2285	Error	Stepper motor card X40 insulation error (Sewing foot lift)	<ul style="list-style-type: none"> • Check motor phase and PE for low-impedance connection • Replace encoder • Replace sewing motor
2286	Error	Software error	<ul style="list-style-type: none"> • Perform reset • Perform software update • Contact customer service
2287	Error	Stepper motor card X40 transport interval failure (Sewing foot lift)	<ul style="list-style-type: none"> • Perform software update • Check selection of class
2288	Error	Stepper motor card X40 Reference run failure (Sewing foot lift)	<ul style="list-style-type: none"> • Eliminate stiff movement in the machine • Replace encoder • Replace motor

Code	Type	Possible cause	Remedial action
2301	Error	Stepper motor card X50 Reference run failure (Stitch length)	<ul style="list-style-type: none"> • Check reference sensor
2302	Error	Z-axis stepper motor: <ul style="list-style-type: none"> • Stepper motor not moving freely or blocked • Encoder cable not connected or defective • Stepper motor cable is not connected or faulty • Encoder defective • Stepper motor faulty 	<ul style="list-style-type: none"> • Remove the cause of the stiff movement or blockage • Check the encoder cable and replace, if necessary • Replace encoder • If the stepper motor is not supplied with current: <ul style="list-style-type: none"> • Check the stepper motor cable and replace, if necessary • Replace stepper motor
2303	Error	Z-axis stepper motor step losses: <ul style="list-style-type: none"> • Stiff mechanical movement or blockage 	<ul style="list-style-type: none"> • Remove the cause of the stiff mechanical movement or blockage
2305	Error	Stepper motor card X50 stepper motor blockage	<ul style="list-style-type: none"> • Eliminate stiff movement in the machine
2321	Error	Stepper motor card X50 encoder plug (Sub-D, 9-pin) not connected	<ul style="list-style-type: none"> • Connect encoder cable to the control, use the correct interface
2322	Error	Stepper motor card X50 rotor position not found	<ul style="list-style-type: none"> • Check stepper motor 1 for stiff movement
2330	Error	Stepper motor card X50 not responding	<ul style="list-style-type: none"> • Perform software update • Replace control
2331	Error	Stepper motor card X50 parameter init error	<ul style="list-style-type: none"> • Perform software update • Check selection of class
2352	Error	Stepper motor card X50 overcurrent	<ul style="list-style-type: none"> • Eliminate stiff movement in the machine
2353	Error	Overvoltage	<ul style="list-style-type: none"> • Check mains voltage
2355	Error	Z-axis stepper motor over- load (I ² T): <ul style="list-style-type: none"> • Stepper motor not moving freely or blocked • Stepper motor faulty • Control defective 	<ul style="list-style-type: none"> • Remove the blockage or the cause of the stiff movement • Replace stepper motor • Replace control

Code	Type	Possible cause	Remedial action
2356	Error	Z-axis stepper motor: <ul style="list-style-type: none"> • Stepper motor sluggish • Stepper motor faulty • Control defective 	<ul style="list-style-type: none"> • Eliminate sluggishness • Replace stepper motor • Replace control
2362	Error	Z-axis stepper motor disturbance (IDMA auto increment)	<ul style="list-style-type: none"> • Switch off and on the machine
2371	Error	Stepper motor card X50 Watchdog (sewing foot lift)	<ul style="list-style-type: none"> • Perform software update • Check selection of class
2372	Error	Stepper motor card X50 motor overload / overvoltage / overcurrent (Sewing foot stroke)	<ul style="list-style-type: none"> • Check selection of class • Replace control • Replace encoder • Replace stepper motor
2373	Error	Stepper motor card X50 Sewing motor encoder not connected (Sewing foot stroke)	<ul style="list-style-type: none"> • Replace control
2374	Error	Stepper motor card X50 Sewing motor encoder not init (Sewing foot stroke)	<ul style="list-style-type: none"> • Perform software update • Check selection of class
2375	Error	Stepper motor card X50 Init Position not found (Sewing foot stroke)	<ul style="list-style-type: none"> • Eliminate stiff movement in the machine • Replace encoder • Replace motor
2376	Error	Stepper motor card X50 not Enabled (Sewing foot stroke)	<ul style="list-style-type: none"> • Replace control
2377	Error	Stepper motor card X50 Overload (Sewing foot stroke)	<ul style="list-style-type: none"> • Eliminate stiff movement in the machine • Replace encoder • Replace motor
2378	Error	Stepper motor card X50 Encoder failure (Sewing foot stroke)	<ul style="list-style-type: none"> • Replace encoder
2379	Error	Stepper motor card X50 Current sensor failure (Sewing foot stroke)	<ul style="list-style-type: none"> • Replace control

Code	Type	Possible cause	Remedial action
2380	Error	Stepper motor card X50 Incorrect stepper motor direction of rotation (Sewing foot stroke)	<ul style="list-style-type: none"> • Replace encoder • Check if plugs have been mixed up • Check the wiring in the machine distribu- tor and change it if necessary
2381	Error	Stepper motor card X50 Reference run failure (Sewing foot stroke)	<ul style="list-style-type: none"> • Eliminate stiff movement in the machine • Replace encoder • Replace motor
2382	Error	Stepper motor current error	<ul style="list-style-type: none"> • Remove blockage • Check the encoder cable and replace, if necessary • Replace stepper motor
2383	Error	Stepper motor card X50 overcurrent (Sewing foot stroke)	<ul style="list-style-type: none"> • Replace control
2384	Error	Stepper motor card X50 parameter init (Sewing foot stroke)	<ul style="list-style-type: none"> • Perform software update • Check selection of class
2385	Error	Stepper motor card X50 insulation error (Sewing foot stroke)	<ul style="list-style-type: none"> • Check motor phase and PE for low- impedance connection • Replace encoder • Replace sewing motor
2386	Error	Software error	<ul style="list-style-type: none"> • Perform reset • Perform software update • Contact customer service
2387	Error	Stepper motor card X50 transport interval failure (Sewing foot stroke)	<ul style="list-style-type: none"> • Perform software update • Check selection of class
2388	Error	Stepper motor card X50 Reference run failure (Sewing foot stroke)	<ul style="list-style-type: none"> • Eliminate stiff movement in the machine • Replace encoder • Replace motor
2401	Error	Stepper motor card X60 reference run timeout (Edge guide)	<ul style="list-style-type: none"> • Check reference sensor

Code	Type	Possible cause	Remedial action
2402	Error	U-axis stepper motor: <ul style="list-style-type: none"> • Stepper motor not moving freely or blocked • Encoder cable not connected or defective • Stepper motor cable is not connected or faulty • Encoder defective • Stepper motor faulty 	<ul style="list-style-type: none"> • Remove the cause of the stiff movement or blockage • Check the encoder cable and replace, if necessary • Replace encoder If the stepper motor is not supplied with current: <ul style="list-style-type: none"> • Check the stepper motor cable and replace, if necessary • Replace stepper motor
2403	Error	U-axis stepper motor step losses: <ul style="list-style-type: none"> • Stiff mechanical movement or blockage 	<ul style="list-style-type: none"> • Remove the cause of the stiff mechanical movement or blockage
2405	Error	Stepper motor card X60 stepper motor blockage (motorized edge guide)	<ul style="list-style-type: none"> • Eliminate stiff movement in the machine
2421	Error	Stepper motor card X60 encoder plug (Sub-D, 9-pin) not connected	<ul style="list-style-type: none"> • Connect encoder cable to the control, use the correct interface
2422	Error	Stepper motor card X60 rotor position not found	<ul style="list-style-type: none"> • Check stepper motor 1 for stiff movement
2430	Error	Stepper motor card X60 not responding	<ul style="list-style-type: none"> • Perform software update • Replace control
2431	Error	Stepper motor card X60 parameter init error	<ul style="list-style-type: none"> • Perform software update • Check selection of class
2452	Error	U-axis stepper motor over current	<ul style="list-style-type: none"> • Replace stepper motor
2453	Error	Overvoltage	<ul style="list-style-type: none"> • Check mains voltage
2455	Error	U-axis stepper motor overload (I ² T): <ul style="list-style-type: none"> • Stepper motor not moving freely or blocked • Stepper motor faulty • Control defective 	<ul style="list-style-type: none"> • Remove the blockage or the cause of the stiff movement • Replace stepper motor • Replace control

Code	Type	Possible cause	Remedial action
2456	Error	U-axis stepper motor: <ul style="list-style-type: none"> • Stepper motor sluggish • Stepper motor faulty • Control defective 	<ul style="list-style-type: none"> • Eliminate sluggishness • Replace stepper motor • Replace control
2462	Error	<ul style="list-style-type: none"> • U-axis stepper motor disturbance (IDMA auto increment) 	<ul style="list-style-type: none"> • Switch off and on the machine
2471	Error	Stepper motor card X60 Watchdog (motorized edge guide)	<ul style="list-style-type: none"> • Perform software update • Check selection of class
2472	Error	Stepper motor card X60 motor overload / overvoltage / overcurrent (motorized edge guide)	<ul style="list-style-type: none"> • Check selection of class • Replace control • Replace encoder • Replace stepper motor
2473	Error	Stepper motor card X60 Sewing motor encoder not connected (motorized edge guide)	<ul style="list-style-type: none"> • Replace control
2474	Error	Stepper motor card X60 Sewing motor encoder not init (motorized edge guide)	<ul style="list-style-type: none"> • Perform software update • Check selection of class
2475	Error	Stepper motor card X60 Init Position not found (motorized edge guide)	<ul style="list-style-type: none"> • Eliminate stiff movement in the machine • Replace encoder • Replace motor
2476	Error	Stepper motor card X60 not Enabled (motorized edge guide)	<ul style="list-style-type: none"> • Replace control
2477	Error	Stepper motor card X60 Overload (motorized edge guide)	<ul style="list-style-type: none"> • Eliminate stiff movement in the machine • Replace encoder • Replace motor
2478	Error	Stepper motor card X60 Encoder failure (motorized edge guide)	<ul style="list-style-type: none"> • Replace encoder

Code	Type	Possible cause	Remedial action
2479	Error	Stepper motor card X60 Current sensor failure (motorized edge guide)	<ul style="list-style-type: none"> • Replace control
2480	Error	Stepper motor card X60 Incorrect stepper motor direction of rotation (motorized edge guide)	<ul style="list-style-type: none"> • Replace encoder • Check if plugs have been mixed up • Check the wiring in the machine distributor and change it if necessary
2481	Error	Stepper motor card X60 Reference run failure (motorized edge guide)	<ul style="list-style-type: none"> • Eliminate stiff movement in the machine • Replace encoder • Replace motor
2482	Error	Stepper motor current error	<ul style="list-style-type: none"> • Remove blockage • Check the encoder cable and replace, if necessary • Replace stepper motor
2483	Error	Stepper motor card X60 overcurrent (motorized edge guide)	<ul style="list-style-type: none"> • Replace control
2484	Error	Stepper motor card X60 parameter init (motorized edge guide)	<ul style="list-style-type: none"> • Perform software update • Check selection of class
2485	Error	Stepper motor card X60 insulation error (motorized edge guide)	<ul style="list-style-type: none"> • Check motor phase and PE for low-impedance connection • Replace encoder • Replace sewing motor
2486	Error	Software error	<ul style="list-style-type: none"> • Perform reset • Perform software update • Contact customer service
2487	Error	Stepper motor card X60 transport interval failure (Edge guide)	<ul style="list-style-type: none"> • Perform software update • Check selection of class
2488	Error	Stepper motor card X60 Reference run failure (motorized edge guide)	<ul style="list-style-type: none"> • Eliminate stiff movement in the machine • Replace encoder • Replace motor
2501	Error	Stepper motor card X70 reference run timeout (upper Puller)	<ul style="list-style-type: none"> • Check reference sensor

Code	Type	Possible cause	Remedial action
2505	Error	Stepper motor card X70 stepper motor blockage (upper Puller)	<ul style="list-style-type: none"> • Eliminate stiff movement in the machine
2521	Error	Stepper motor card X70 encoder plug (Sub-D, 9-pin) not connected	<ul style="list-style-type: none"> • Connect encoder cable to the control, use the correct interface
2522	Error	Stepper motor card X70 rotor position not found	<ul style="list-style-type: none"> • Check stepper motor 1 for stiff movement
2530	Error	Stepper motor card X70 not responding	<ul style="list-style-type: none"> • Perform software update • Replace control
2531	Error	Stepper motor card X70 parameter init error	<ul style="list-style-type: none"> • Perform software update • Check selection of class
2571	Error	Stepper motor card X70 Watchdog (upper Puller)	<ul style="list-style-type: none"> • Perform software update • Check selection of class
2572	Error	Stepper motor card X70 motor overload / overvoltage / overcurrent (upper Puller)	<ul style="list-style-type: none"> • Check selection of class • Replace control • Replace encoder • Replace stepper motor
2573	Error	Stepper motor card X70 Sewing motor encoder not connected (upper Puller)	<ul style="list-style-type: none"> • Replace control
2574	Error	Stepper motor card X70 Sewing motor encoder not init (upper Puller)	<ul style="list-style-type: none"> • Perform software update • Check selection of class
2575	Error	Stepper motor card X70 Init Position not found (upper Puller)	<ul style="list-style-type: none"> • Eliminate stiff movement in the machine • Replace encoder • Replace motor
2576	Error	Stepper motor card X70 not Enabled (upper Puller)	<ul style="list-style-type: none"> • Replace control
2577	Error	Stepper motor card X70 Overload (upper Puller)	<ul style="list-style-type: none"> • Eliminate stiff movement in the machine • Replace encoder • Replace motor

Code	Type	Possible cause	Remedial action
2578	Error	Stepper motor card X70 Encoder failure (upper Puller)	<ul style="list-style-type: none"> • Replace encoder
2579	Error	Stepper motor card X70 Current sensor failure (upper Puller)	<ul style="list-style-type: none"> • Replace control
2580	Error	Stepper motor card X70 Incorrect stepper motor direction of rotation (upper Puller)	<ul style="list-style-type: none"> • Replace encoder • Check if plugs have been mixed up • Check the wiring in the machine distributor and change it if necessary
2581	Error	Stepper motor card X70 Reference run failure (upper Puller)	<ul style="list-style-type: none"> • Eliminate stiff movement in the machine • Replace encoder • Replace motor
2583	Error	Stepper motor card X70 overcurrent (upper Puller)	<ul style="list-style-type: none"> • Replace control
2584	Error	Stepper motor card X70 parameter init (upper Puller)	<ul style="list-style-type: none"> • Perform software update • Check selection of class
2585	Error	Stepper motor card X70 insulation error (upper Puller)	<ul style="list-style-type: none"> • Check motor phase and PE for low-impedance connection • Replace encoder • Replace sewing motor
2587	Error	Stepper motor card X70 transport interval failure (upper Puller)	<ul style="list-style-type: none"> • Perform software update • Check selection of class
2588	Error	Stepper motor card X70 Reference run failure (upper Puller)	<ul style="list-style-type: none"> • Eliminate stiff movement in the machine • Replace encoder • Replace motor
2601	Error	Stepper motor X80 reference run timeout (bottom puller)	<ul style="list-style-type: none"> • Check reference sensor
2605	Error	Stepper motor card X80 stepper motor blockage (bottom puller)	<ul style="list-style-type: none"> • Eliminate stiff movement in the machine

Code	Type	Possible cause	Remedial action
2621	Error	Stepper motor card X82 encoder plug (Sub-D, 9-pin) not connected (bottom puller)	<ul style="list-style-type: none"> • Connect encoder cable to the control, use the correct interface
2622	Error	Stepper motor card X80 rotor position not found (bottom puller)	<ul style="list-style-type: none"> • Check stepper motor 6 for stiff movement
2630	Error	Stepper motor card X80 not responding (bottom puller)	<ul style="list-style-type: none"> • Perform software update • Replace control
2631	Error	Stepper motor card X80 init failure (bottom puller)	<ul style="list-style-type: none"> • Perform software update • Check selection of class
2671	Error	Stepper motor card X80 Watchdog (bottom puller)	<ul style="list-style-type: none"> • Perform software update • Check selection of class
2672	Error	Stepper motor card X80 motor overload / overvoltage / overcurrent (bottom puller)	<ul style="list-style-type: none"> • Check selection of class • Replace control • Replace encoder • Replace stepper motor
2673	Error	Stepper motor card X80 Sewing motor encoder not connected (bottom puller)	<ul style="list-style-type: none"> • Replace control
2674	Error	Stepper motor card X80 Sewing motor encoder not init (bottom puller)	<ul style="list-style-type: none"> • Perform software update • Check selection of class
2675	Error	Stepper motor card X80 Init Position not found (bottom puller)	<ul style="list-style-type: none"> • Eliminate stiff movement in the machine • Replace encoder • Replace motor
2676	Error	Stepper motor card X80 not Enabled (bottom puller)	<ul style="list-style-type: none"> • Replace control
2677	Error	Stepper motor card X80 I ² t (bottom puller)	<ul style="list-style-type: none"> • Eliminate stiff movement in the machine • Replace encoder • Replace motor

Code	Type	Possible cause	Remedial action
2678	Error	Stepper motor card X80 Encoder failure (bottom puller)	<ul style="list-style-type: none"> • Replace encoder
2679	Error	Stepper motor card X80 Current sensor failure (bottom puller)	<ul style="list-style-type: none"> • Replace control
2680	Error	Stepper motor card X80 Incorrect stepper motor direction of rotation (bottom puller)	<ul style="list-style-type: none"> • Replace encoder • Check if plugs have been mixed up • Check the wiring in the machine distributor and change it if necessary
2681	Error	Stepper motor card X80 Reference run failure (bottom puller)	<ul style="list-style-type: none"> • Eliminate stiff movement in the machine • Replace encoder • Replace motor
2683	Error	Stepper motor card X80 overcurrent (bottom puller)	<ul style="list-style-type: none"> • Replace control
2684	Error	Stepper motor card X80 parameter init (bottom puller)	<ul style="list-style-type: none"> • Perform software update • Check selection of class
2685	Error	Stepper motor card X80 insulation error (bottom puller)	<ul style="list-style-type: none"> • Check motor phase and PE for low-impedance connection • Replace encoder • Replace sewing motor
2687	Error	Stepper motor card X80 transport interval failure (bottom puller)	<ul style="list-style-type: none"> • Perform software update • Check selection of class
2688	Error	Stepper motor card X80 Reference run failure (bottom puller)	<ul style="list-style-type: none"> • Eliminate stiff movement in the machine • Replace encoder • Replace motor
2901	Error	General Reference Timeout of the stepper motors	<ul style="list-style-type: none"> • Check the reference sensors
3010	Error	U100 V start-up error	<ul style="list-style-type: none"> • Disconnect the stepper motor plugs; if error persists, replace control
3011	Error	U100 V short circuit	<ul style="list-style-type: none"> • Disconnect motor plug; replace control if error is not corrected: Replace control

Code	Type	Possible cause	Remedial action
3012	Error	U100 V (I ² T) overload	<ul style="list-style-type: none"> • one or several stepper motors defective
3020	Error	U24 V start-up error	<ul style="list-style-type: none"> • Disconnect magnet plug; replace control if error is not corrected: Replace control
3021	Error	U24 V short circuit	<ul style="list-style-type: none"> • Disconnect magnet plug; replace control if error is not corrected: Replace control
3022	Error	U24 V (I ² T) overload	<ul style="list-style-type: none"> • One or several magnets defective
3030	Error	Motor phase failure	<ul style="list-style-type: none"> • Replace control
3104	Warning	Pedal is not in position 0	<ul style="list-style-type: none"> • When switching the control on, take your foot off the pedal
3109	Warning	Operation lock	<ul style="list-style-type: none"> • Check tilt sensor on machine
3110	Information	Right thread tension magnet is not connected	<ul style="list-style-type: none"> • Check the connection of right thread tension magnet
3111	Information	Left thread tension magnet is not connected	<ul style="list-style-type: none"> • Check the connection of left thread tension magnet
3150	Information	Maintenance necessary	<ul style="list-style-type: none"> • For information on maintenance of the machine, see the service instructions for the machine
3217	Information	RFW right	<ul style="list-style-type: none"> • Bobbin is empty • Insert a new bobbin
3223	Information	Skip stitch detection	<ul style="list-style-type: none"> • -
3224	Information	Bobbin rotation monitor	<ul style="list-style-type: none"> • The bobbin is not rotating • Check the bobbin, advance the initial thread
3225	Information	SSD sensor is soiled	<ul style="list-style-type: none"> • Use compressed air or a soft cotton cloth to clean the sensor
3354	Information	Failure in thread trimmer process	<ul style="list-style-type: none"> • Perform software update
3383	Information	Failure in with the motor referencing process	<ul style="list-style-type: none"> • Check motor • Perform software update
4201	Warning	Failure SD-Card	<ul style="list-style-type: none"> • Insert SD card • Replace control

Code	Type	Possible cause	Remedial action
4460	Warning	OP7000 connection lost	<ul style="list-style-type: none"> • Check connection to OP7000 • Replace OP7000 • Replace control
4906	Information	Not in translation table	<ul style="list-style-type: none"> • Check machine ID port • Reset or machine class change necessary
4907	Information	Not in translation table	<ul style="list-style-type: none"> • Reset or machine class change necessary
4908	Information	Not in translation table	<ul style="list-style-type: none"> • Reset necessary
4911	Information	Not in translation table	<ul style="list-style-type: none"> • Reset necessary
4918	Warning	Invalid update file	<ul style="list-style-type: none"> • Contact DA Service
4919	Warning	Reset failed	<ul style="list-style-type: none"> • Contact DA Service
4920	Warning	Error in update log	<ul style="list-style-type: none"> • Contact DA Service
4921	Warning	The update was interrupted	<ul style="list-style-type: none"> • Contact DA Service
4922	Error	Unable to find user database	<ul style="list-style-type: none"> • Contact DA Service
4923	Error	Synchronization failed	<ul style="list-style-type: none"> • Contact DA Service
4930	Information	Control replaced	<ul style="list-style-type: none"> • Data transfer from control panel to control
4931	Information	Checksum error of the control	<ul style="list-style-type: none"> • Data transfer from control panel to control
6353	Error	EEProm Timeout	<ul style="list-style-type: none"> • Switch off the control, wait until the LEDs are off, check connection for machine ID, and switch on control again
5001	Information	Incorrect class	<ul style="list-style-type: none"> • Change class • Perform reset
5002	Information	Incorrect class or machine ID connection error	<ul style="list-style-type: none"> • Change class • Perform reset
5003	Information	Data version is too old	<ul style="list-style-type: none"> • Perform reset
5004	Information	Checksum is incorrect	<ul style="list-style-type: none"> • Perform reset
6000 to 6299	Error	Internal error	<ul style="list-style-type: none"> • Switch off and on the machine • Perform software update • Contact customer service











Code	Type	Possible cause	Remedial action
6351 to 6354	Error	Control defective (I ² C)	<ul style="list-style-type: none"> • Replace control
6360	Information	No valid data on external EEPROM (internal data structures are not compatible with the external data storage device)	<ul style="list-style-type: none"> • Software update
6361	Information	No external EEPROM connected	<ul style="list-style-type: none"> • Connect machine ID
6362	Information	No valid data on internal EEPROM (internal data structures are not compatible with the external data storage device)	<ul style="list-style-type: none"> • Check machine ID connection • Switch off the control, wait until the LEDs have gone out, and then switch on the control again • Software update
6363	Information	No valid data on internal and external EEPROM (software version is not compatible with the internal data storage device, emergency operating features only)	<ul style="list-style-type: none"> • Check machine ID connection • Switch off the control, wait until the LEDs have gone out, and then switch on the control again • Software update
6364	Information	No valid data on internal EEPROM and no external EEPROM connected (the internal data structures are not compatible with the external data storage device)	<ul style="list-style-type: none"> • Check machine ID connection • Switch off the control, wait until the LEDs have gone out, and then switch on the control again • Software update
6365	Information	Internal EEPROM defective	<ul style="list-style-type: none"> • Replace control

Code	Type	Possible cause	Remedial action
6366	Information	Internal EEPROM defective and external data not valid (emergency operating features only)	<ul style="list-style-type: none"> • Replace control
6367	Information	Internal EEPROM defective and external data not valid (emergency operating features only)	<ul style="list-style-type: none"> • Replace control
6400 to 6999	Error	Internal error	<ul style="list-style-type: none"> • Switch off and on the machine • Perform software update • Contact customer service
7270	Information	External CAN	<ul style="list-style-type: none"> • Check connection cables • Perform software update • Replace CAN slaves
7551 to 7659	Error	<ul style="list-style-type: none"> • Internal error • Cable disturbance • Cables to the control panel interface defective 	<ul style="list-style-type: none"> • Switch off and on the machine • Eliminate source of disturbance • Perform software update • Replace cable • Contact customer service
9310	Error	Tape feeder not connected	<ul style="list-style-type: none"> • Check connection cables • Perform software update • Replace the control of the tape feeder
9320	Error	Tape feeder in lowered position	<ul style="list-style-type: none"> • No remedial action entered in translation table
9330	Information	Material thickness sensor not connected	<ul style="list-style-type: none"> • Check connection cables • Perform software update • Replace material thickness sensor
9340	Error	Remaining thread monitor not connected	<ul style="list-style-type: none"> • Check connection cables • Perform software update • Replace remaining thread monitor
9910	Warning	Sewing stop	<ul style="list-style-type: none"> • Check tilt sensor on machine • Check 24V • Replace control
9911	Warning	Power down	<ul style="list-style-type: none"> • The control is switched off
9912	Warning	Restart necessary	<ul style="list-style-type: none"> • Switch off the control
9913	Warning	Empty bobbin	<ul style="list-style-type: none"> • Please insert a full bobbin

Code	Type	Possible cause	Remedial action
9914	Warning	Reset	<ul style="list-style-type: none"> • Remove USB key!
9915	Warning	Please Wait!	<ul style="list-style-type: none"> • Please wait and do not remove USB key
9916	Warning	Erase internal Memory	<ul style="list-style-type: none"> • Delete the SD card. Continue with OK; cancel with ESC
9917	Warning	Erase USB key	<ul style="list-style-type: none"> • Delete the USB key. Continue with OK; cancel with ESC
9918	Warning	No USB key present	<ul style="list-style-type: none"> • Please insert USB key
9919	Warning	Sewing stop	<ul style="list-style-type: none"> • Machine in stop mode for threading the thread
9920	Warning	Referencing	<ul style="list-style-type: none"> • Please wait for motor referencing
9921	Warning	Show Message from QONDAC	<ul style="list-style-type: none"> • Show Message
9922	Warning	Service Stop	<ul style="list-style-type: none"> • Check the Service Stop button • Check 24V • Replace control
9923	Warning	Update required	<ul style="list-style-type: none"> • Press OK for Restart or ESC for cancel
9924	Warning	Security key generated	<ul style="list-style-type: none"> • Creation of a security key on a USB key
9925	Warning	Security Key changed!	<ul style="list-style-type: none"> • Overwrite Security Key?
9926	Warning	Please Confirm Reset	<ul style="list-style-type: none"> • Really reset?
9927	Warning	Reset	<ul style="list-style-type: none"> • Reset successfully
9928	Warning	Referencing?	<ul style="list-style-type: none"> • Press pedal backwards (pedal position-2)
9929	Warning	Not enough thread available	<ul style="list-style-type: none"> • Please insert a full bobbin
9930	Warning	Empty bobbin	<ul style="list-style-type: none"> • Please insert a full bobbin
9931	Information	Bobbin Wind mode	<ul style="list-style-type: none"> • Press pedal backwards exit bobbin wind mode
9932	Information	No program available	<ul style="list-style-type: none"> • Automatic mode is not available without a program. Please use programming mode to define a program.

10.3 Errors in sewing process

Error	Possible causes	Remedial action
Unthreading at seam beginning	Needle thread tension is too firm	Check needle thread tension 📖 p. 43
Thread breaking	Needle thread and hook thread have not been threaded correctly	Check threading path 📖 p. 24 and 📖 p. 27
	Needle is bent or sharp-edged	Replace needle 📖 p. 22
	Needle is not inserted correctly into the needle bar	Insert the needle correctly into the needle bar 📖 p. 22
	The thread used is unsuitable	Use recommended thread 📖 p. 173
	Thread tensions are too tight for the thread used	Check thread tensions 📖 p. 43
Thread breaking	Thread-guiding parts, such as thread tube, thread guide or thread take-up disk, are sharp-edged	Check threading path 📖 p. 24 and 📖 p. 27
	Throat plate, hook or spread have been damaged by the needle	Have parts reworked by qualified specialists

Error	Possible causes	Remedial action
Skip stitches	Needle thread and hook thread have not been threaded correctly	Check threading path  p. 24 and  p. 27
	Needle is blunt or bent	Replace needle  p. 22
	Needle is not inserted correctly into the needle bar	Insert the needle correctly into the needle bar  p. 22
	The needle thickness used is unsuitable	Use recommended needle thickness  p. 173
	The reel stand is assembled incorrectly	Check the assembly of the reel stand  p. 126
	Thread tensions are too tight	Check thread tensions  p. 43
	Throat plate, hook or spread have been damaged by the needle	Have parts reworked by qualified specialists
Loose stitches	Thread tensions are not adjusted to the sewing material, the sewing material thickness or the thread used	Check thread tensions  p. 43
	Needle thread and hook thread have not been threaded correctly	Check threading path  p. 24 and  p. 27
Needle breakage	Needle thickness is unsuitable for the sewing material or the thread	Use recommended needle thickness  p. 173

11 Technical data

11.1 Data and characteristic values

Technical data	Unit	550-12-33	550-12-34								
Type of stitches		Double chain stitch									
Hook type		Crossline									
Number of needles		1									
Needle system		933									
Maximum thread strength											
• Cotton	[NeB]	15/3									
• Core spun thr. (polycotton)	[Nm]	25/2									
Stitch length	[mm]	3, 4, 5 and 6 A change of the ruffling value extends the feed length of the top feed and of the differential feed to 8 mm while reducing the feed length of the normal feed to 2.5 mm.									
Width of the reinforcement tape	[mm]	2.25									
Number of stitches (ST) and sewing foot stroke (NFH) are interdependent	[min ⁻¹]	<table border="0"> <tr> <td>NFH</td> <td>ST</td> </tr> <tr> <td>2.5</td> <td>3000</td> </tr> <tr> <td>up to 4</td> <td>2500</td> </tr> <tr> <td>4 or more</td> <td>2000</td> </tr> </table>		NFH	ST	2.5	3000	up to 4	2500	4 or more	2000
NFH	ST										
2.5	3000										
up to 4	2500										
4 or more	2000										
When used as a trimmer without ruffling value		<table border="0"> <tr> <td>2.5</td> <td>3500</td> </tr> </table>		2.5	3500						
2.5	3500										
Knife stroke (convertible to 6 mm)	[mm]	-	8								
Cutting margin	[mm]	-	4.5								

Technical data	Unit	550-12-33	550-12-34
Clearance under the switched-off top blade	[mm]	-	17
Clearance under the sewing feet: • Maximum during lifting • Maximum during sewing	[mm]	15 10	
Mains voltage	[V]	190-240	
Mains frequency	[Hz]	50/60	
Operating pressure	[bar]	6	
Air consumption		0.8	
Power input	[kVA]	1	

11.2 Requirements for trouble-free operation

Compressed air quality must be ensured in accordance with ISO 8573-1: 2010 [7:4:4].

Fig. 84: Wiring diagram

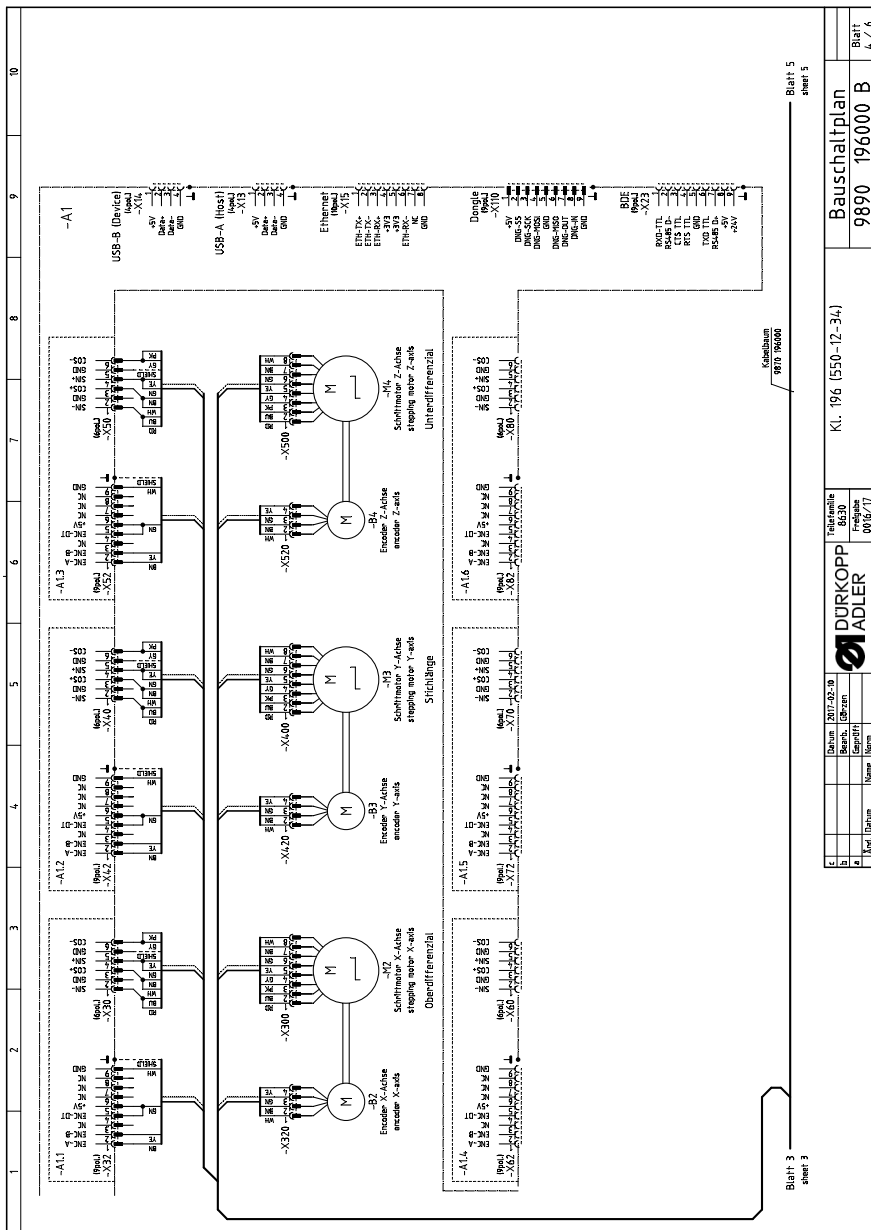

Blatt 5
sheet 5

Bauschaltplan
9890 196000 B

Kl. 196 (550-12-34)

Technische Freigabe	00/05/17
Rechnung 06/30	
Gezeichnet	
Geprüft	
Mont.	
Abgem.	
Notizen	

Blatt 3
sheet 3

Fig. 86: Wiring diagram

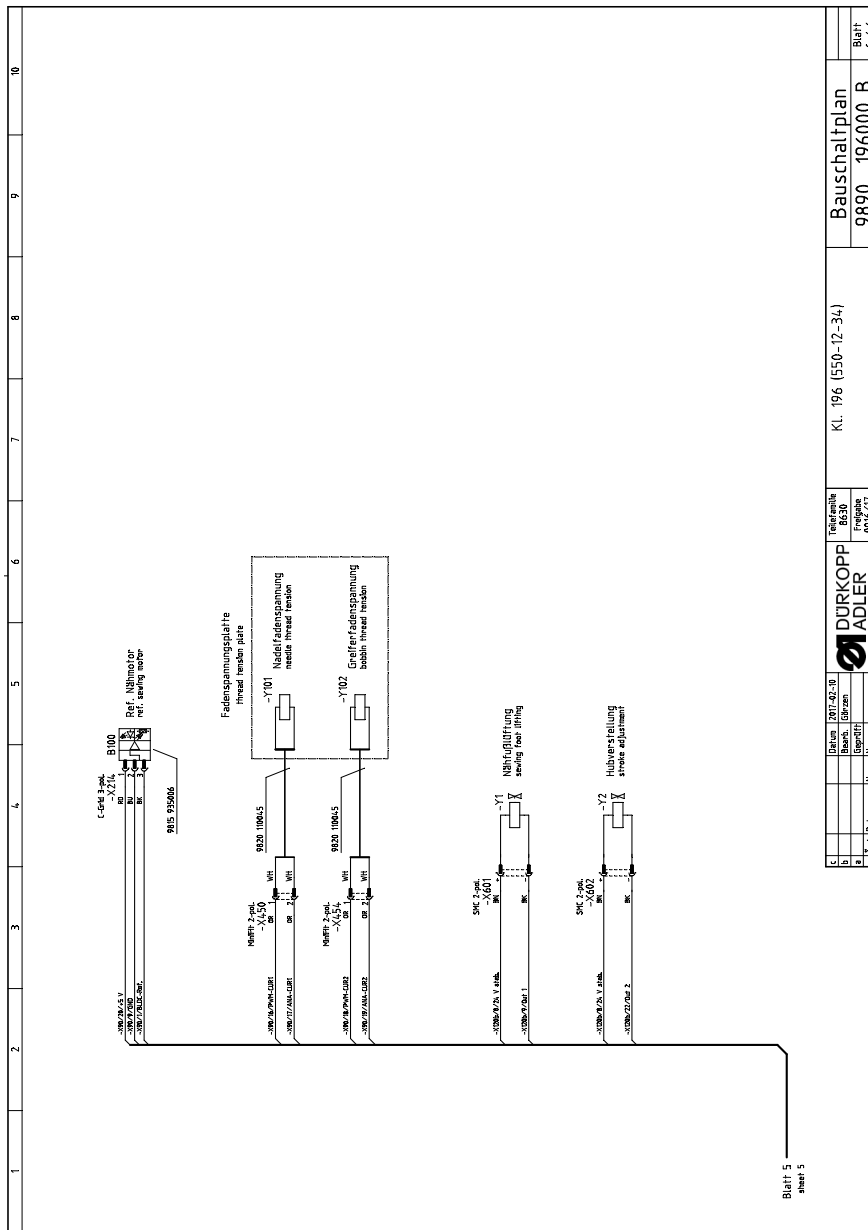

Bauschaltplan		Blatt 8 / 8
9890 - 196000 B		
Kl. 196 (550-12-34)		
Freigegeben 06/16/17		
DURKOPP ADLER		



DÜRKOPP ADLER GmbH

Potsdamer Str. 190

33719 Bielefeld

Germany

Phone: +49 (0) 521 925 00

Email: service@duerkopp-adler.com

www.duerkopp-adler.com