

550-12-33/-34

Teileliste und Näheinrichtungen  
Parts List and Sewing Equipment

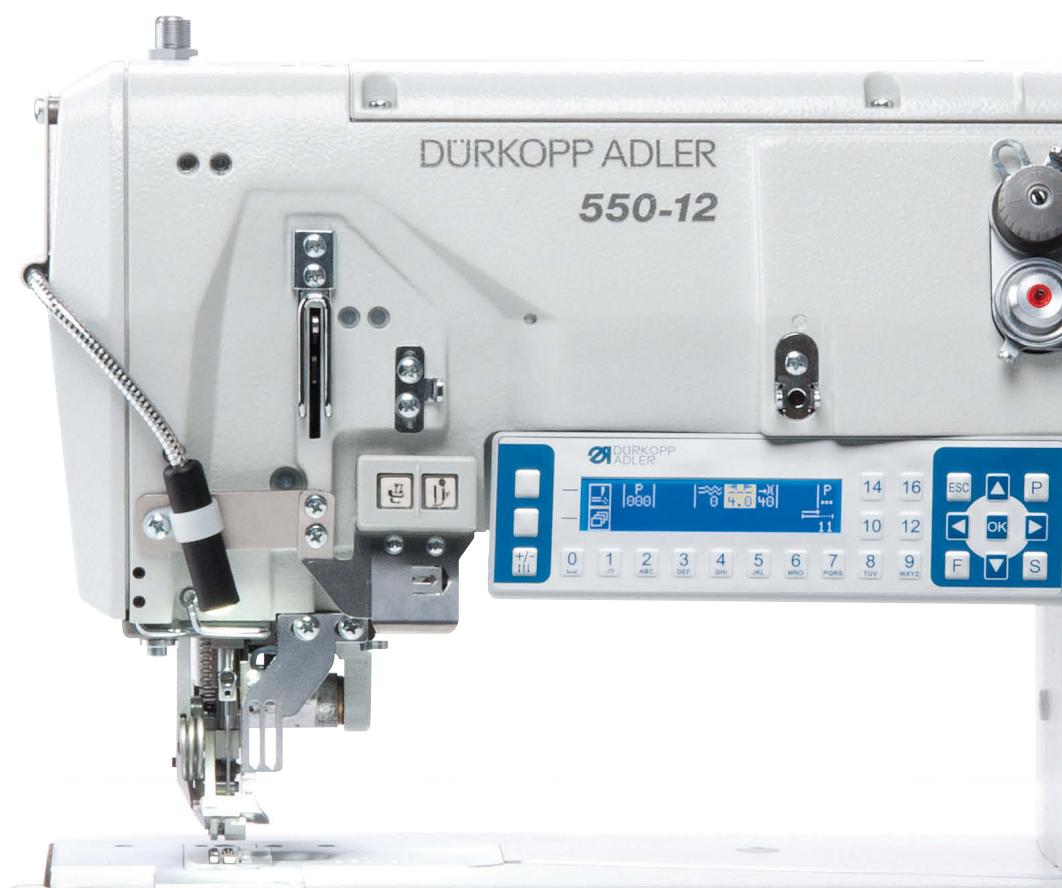

Alle Rechte vorbehalten.

Eigentum der Dürkopp Adler AG und urheberrechtlich geschützt. Jede Wiederverwendung dieser Inhalte, auch in Form von Auszügen, ist ohne vorheriges schriftliches Einverständnis der Dürkopp Adler AG verboten.

All rights reserved.

Property of Dürkopp Adler AG and protected by copyright. Any reuse of these contents, including extracts, is prohibited without the prior written approval of Dürkopp Adler AG.

Copyright © Dürkopp Adler AG 2019

Teileliste und Näheinrichtungen  
 Parts List and Sewing Equipment  
 550-12-33, -34

Inhaltsverzeichnis/Table of Contents

<b>Inhalt</b>	<b>Tafel/Table</b>	<b>Content</b>
Armwelle	1	Arm shaft
Welle, Obertransport	2	Shaft, Top feed
Nadelstangenschwinge, Fadenhebel	3	Needle bar frame, Thread lever
Stichstellergetriebe oben	4	Upper stitch regulator link
Fußstangen, Füßchenlüftung	5	Foot bar, Upper sewing foot lift
Stichstellergetriebe unten, Transportantrieb	6	Lower stitch regulator link, Transport drive
Greiferfadengeber, Stichstellergetriebe, Differential-Untertransport	7	Looper thread feeder, Stitch regulator link differential lower transport
Greifergehäuse, Nadelschutz	8	Hook case, Needle guard
Untervelle, Fadengeberscheibe	9	Lower shaft, Rotary take-up disc
Zugstange, Obertransport	10	Connecting rod, Top feed
Schrittmotore	11	Stepper motor differential transport
Differentialtransport		
Zugstange Untertransport	12	Connecting rod lower transport
Armdeckel	13	Arm cover
Spannungsplatte, Fadenführungen	14	Tension plate, Thread guide
Schmierung	15	Lubrication
Kopfdeckel, Abdeckungen	16	Head cover
Kantenschneider	17	Edge cutter
Abdeckplatten, Fadenführungen	18	Cover plates, Thread guide
Schmierung, Abdeckungen	19	Lubrication, Cover
Nähleuchten	20	Sewing lamp
Nähantrieb	21	Sewing motor
Magnetventile	22	Solenoid valves
Knieschalter, Sollwertgeber, Steuerung	23	Knee switch, Setpoint generator, Control
Gestell	24	Stand
Bundbuchse, Bandrollenhalter unten	25	Flange sleeve, Lower tape-reel bracket
Bundbuchse, Bandrollenhalter oben	26	Flange sleeve, Upper tape-reel bracket
Bedienfeld, Taster	27	Operating panel, Button
Beipack	28	Accessories

Teileliste und Näheinrichtungen  
Parts List and Sewing Equipment  
550-12-33, -34

Inhaltsverzeichnis/Table of Contents

<b>Inhalt</b>	<b>Tafel/Table</b>	<b>Content</b>
Einstell-Lehren	29	Setting gages
Näheinrichtung	30	Sewing Equipment
Näheinrichtung für Kantenschneider	31	Sewing Equipment for edge cutter
Kantenanschlag	32	Edge guide
Pläne		Plans

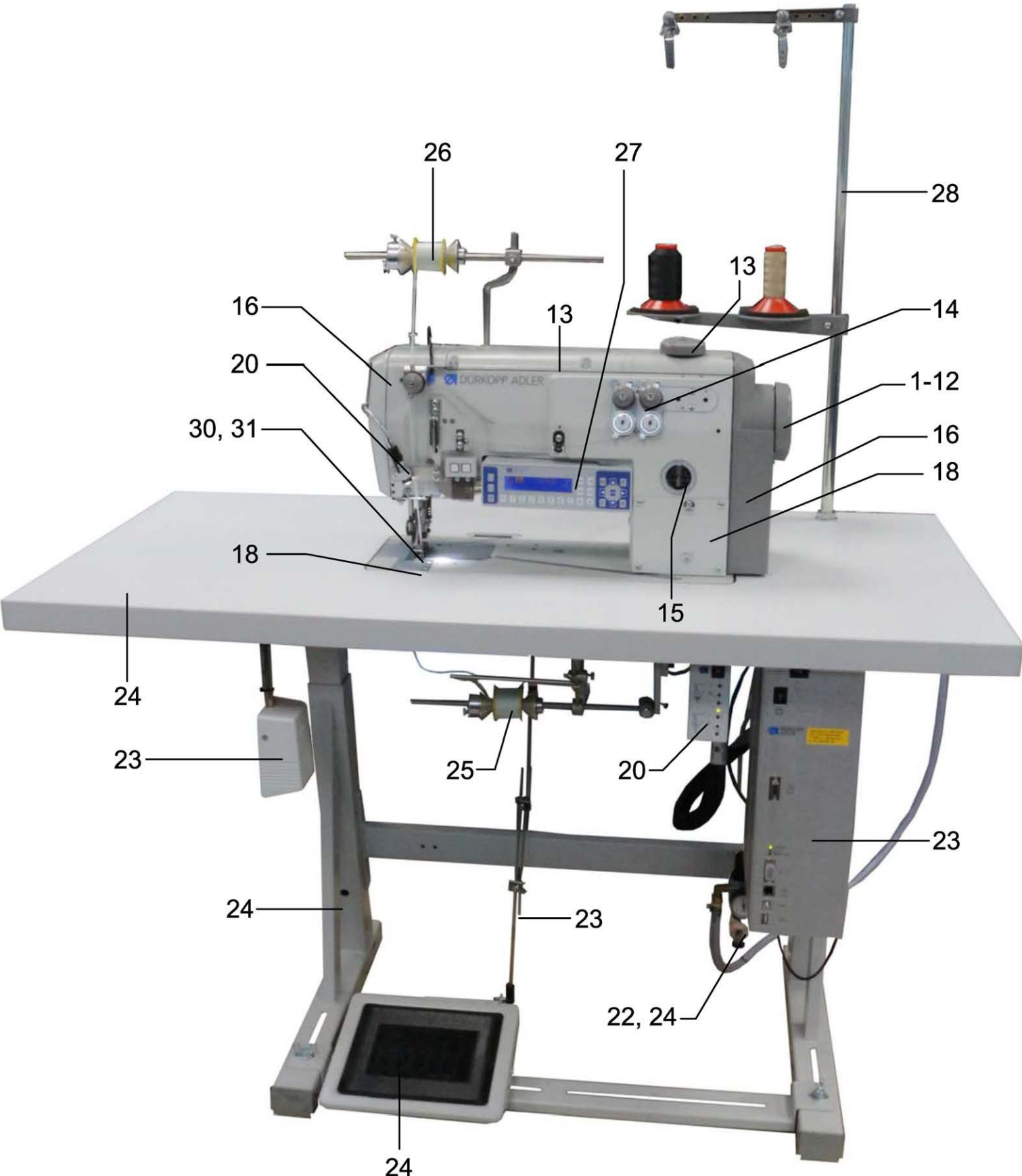

- 1-12
- 13
- 14
- 15
- 16
- 18
- 20
- 22, 24
- 23
- 24
- 25
- 26
- 27
- 30, 31
- 28

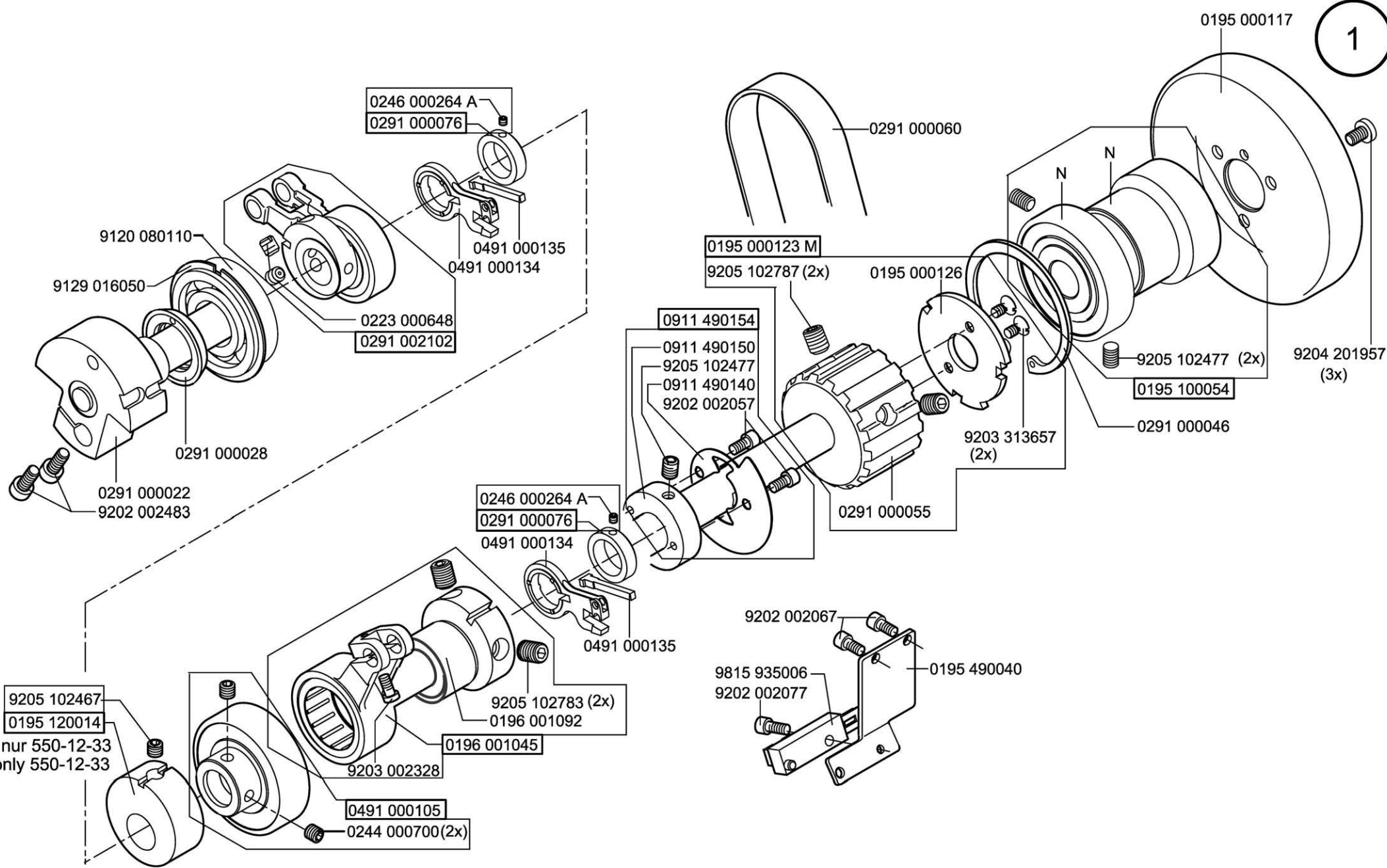

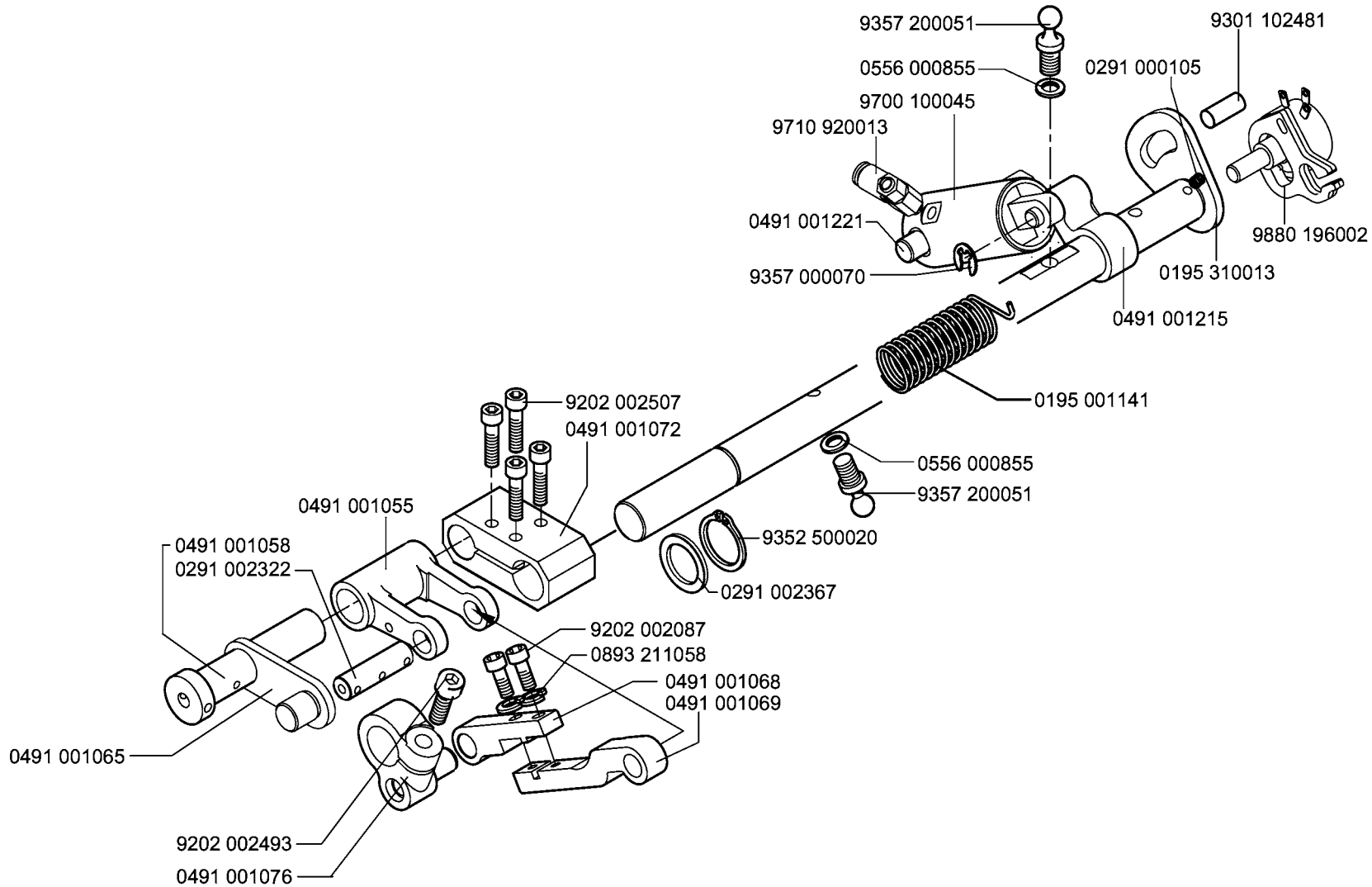

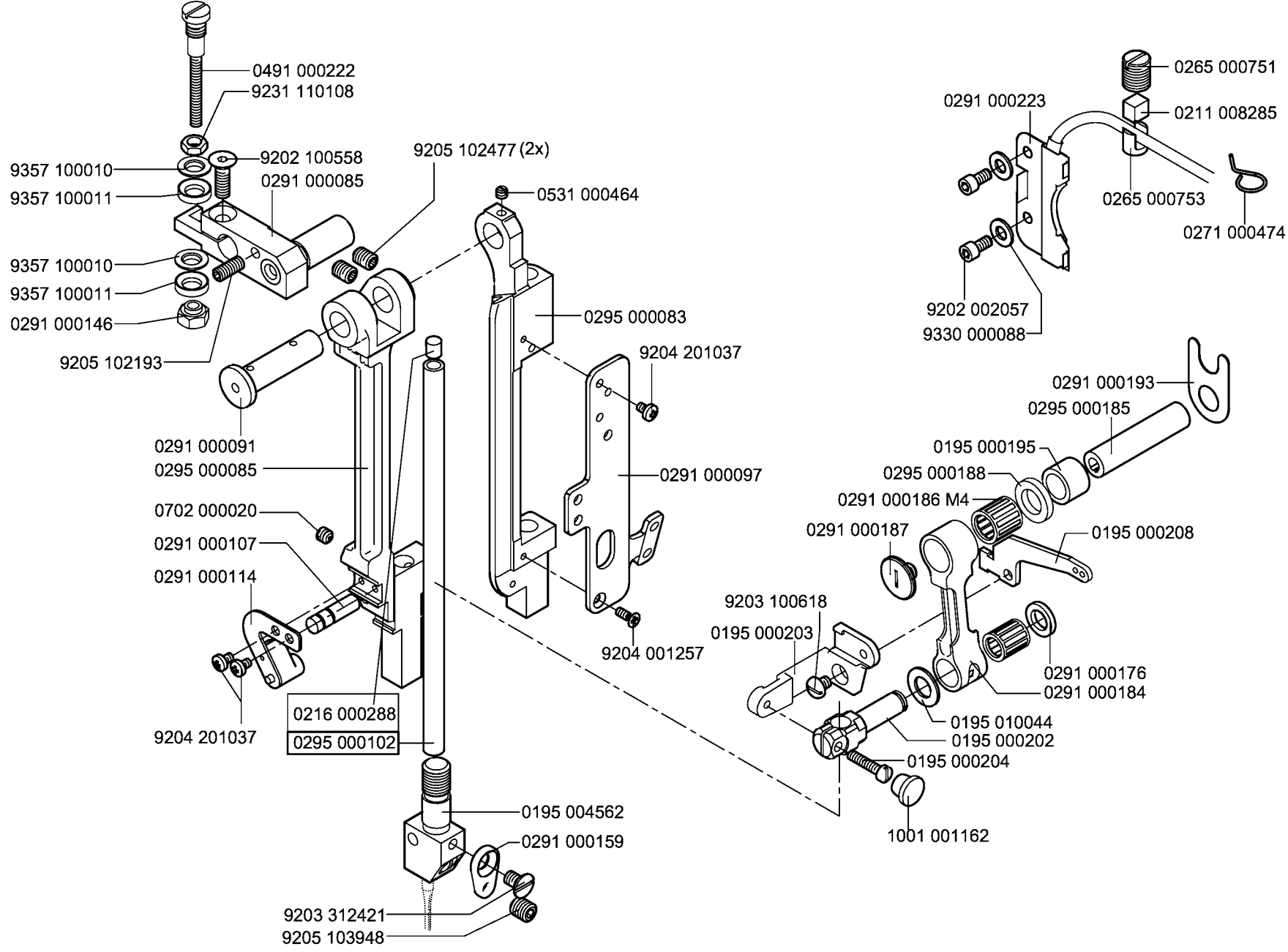

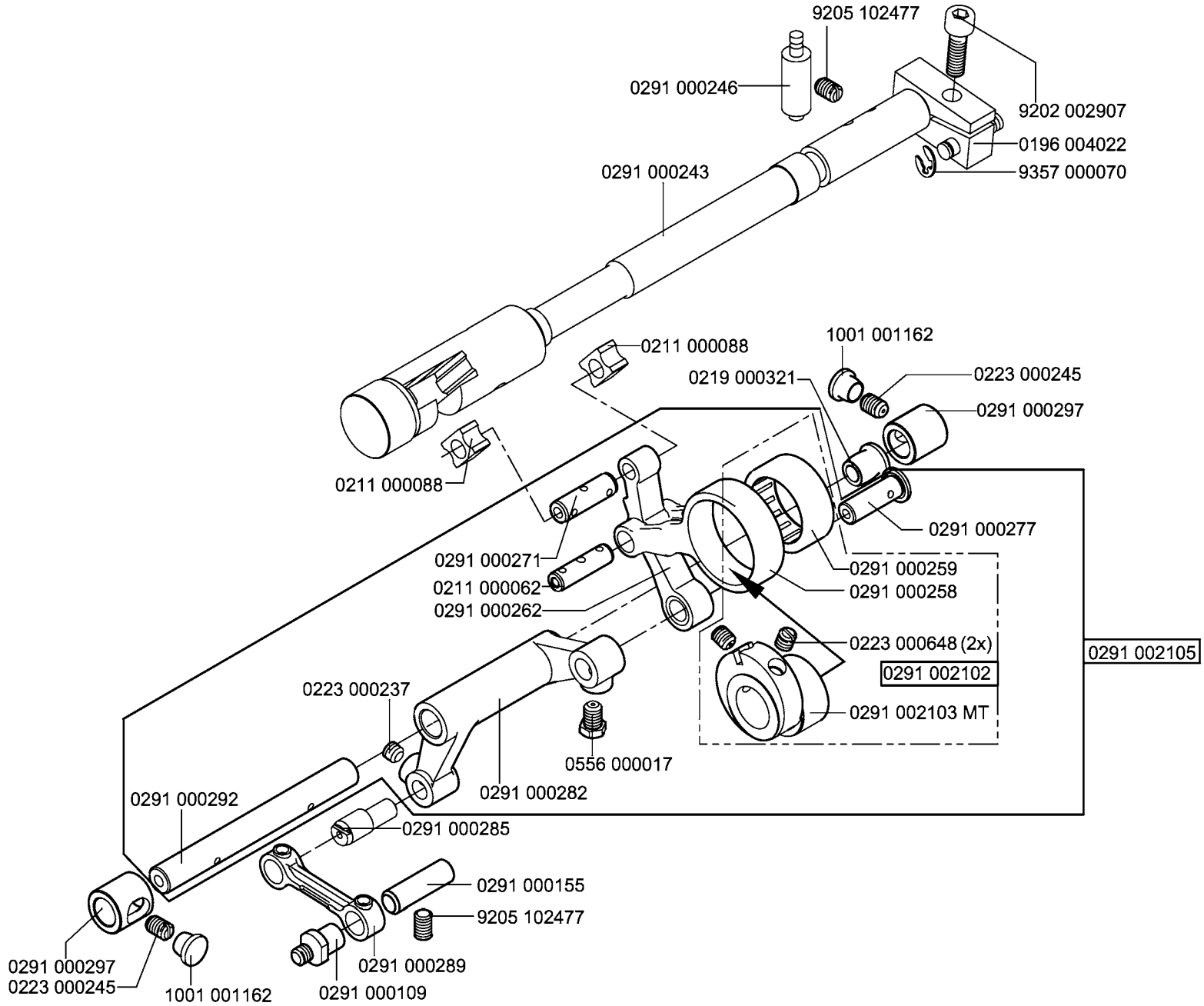

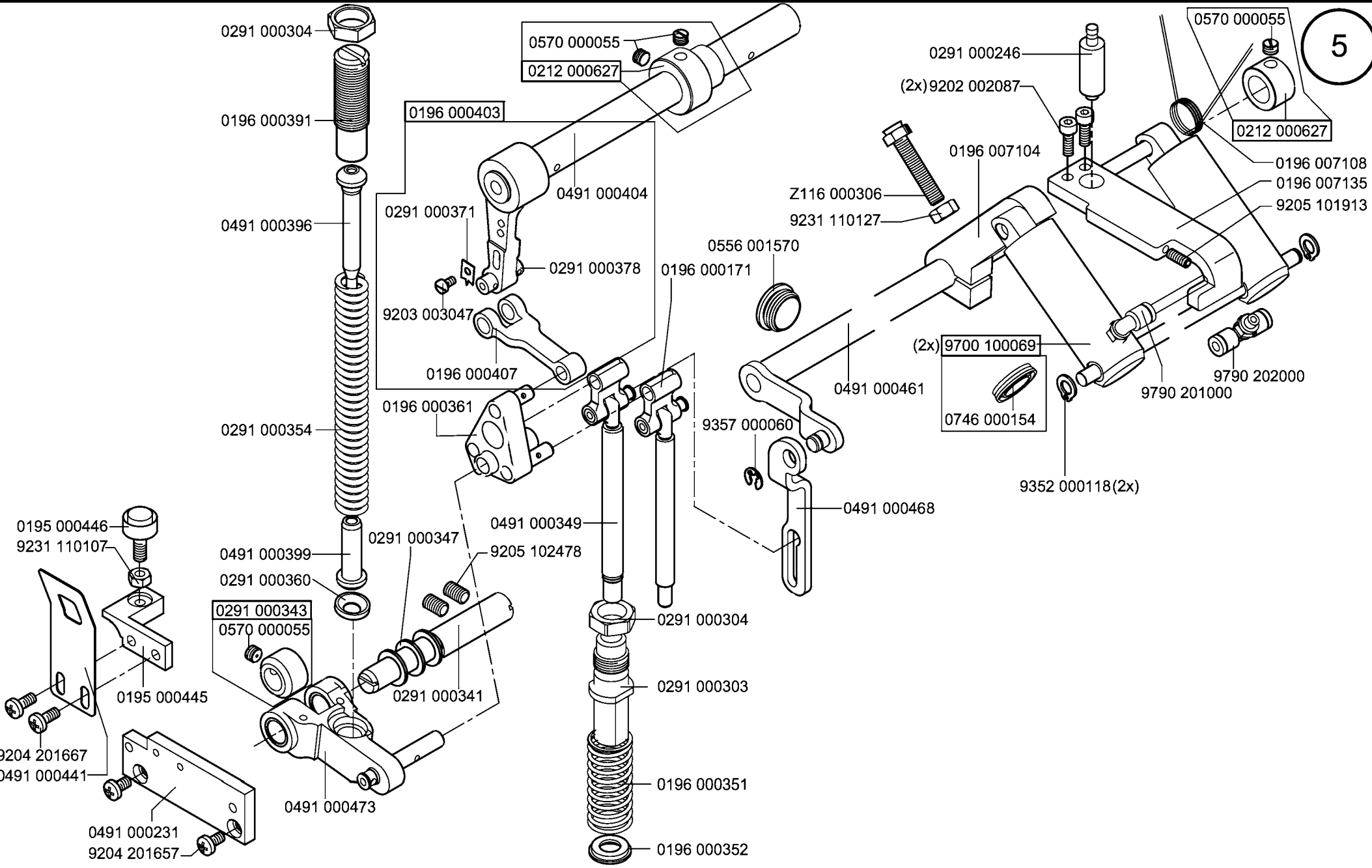

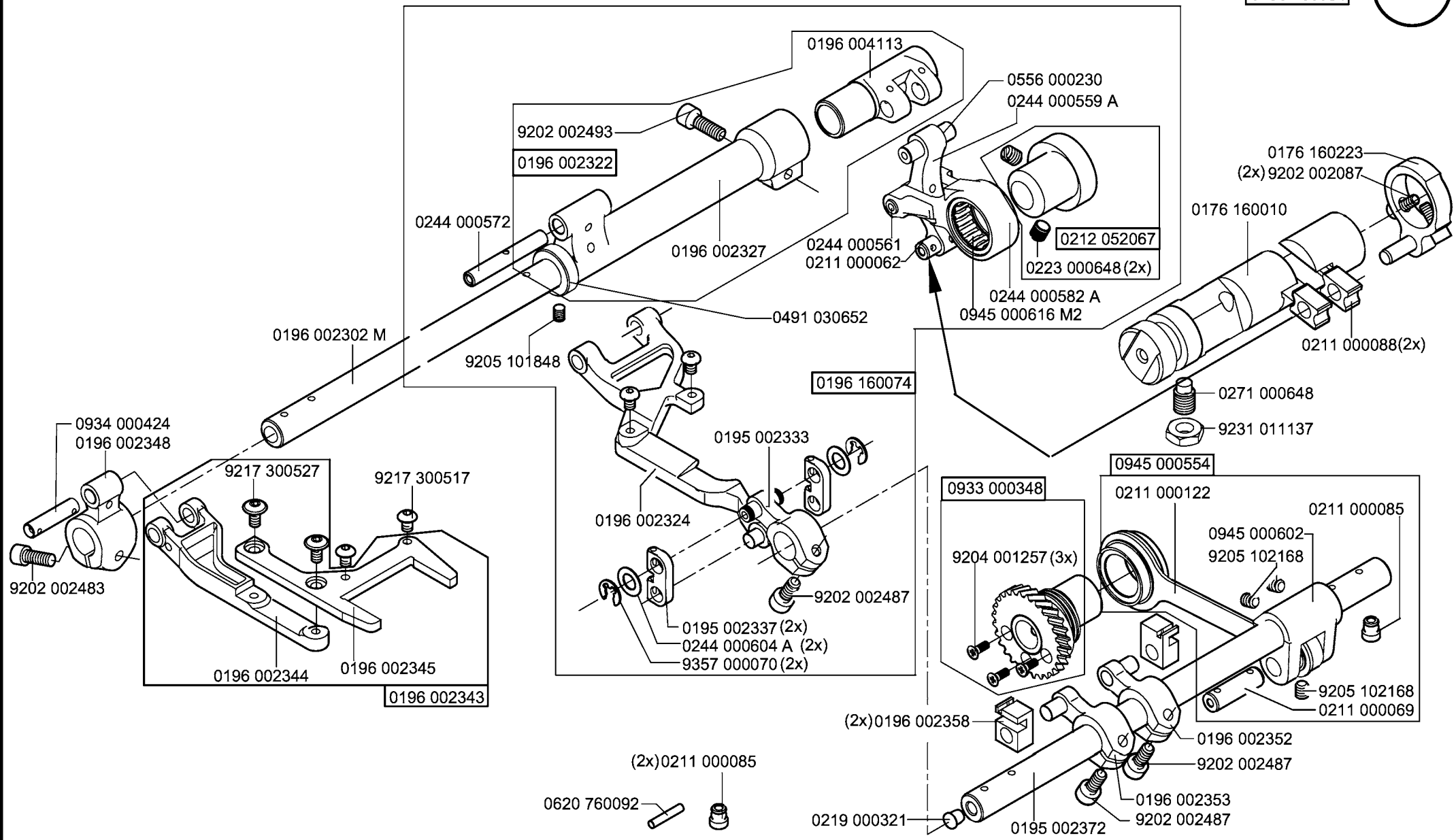

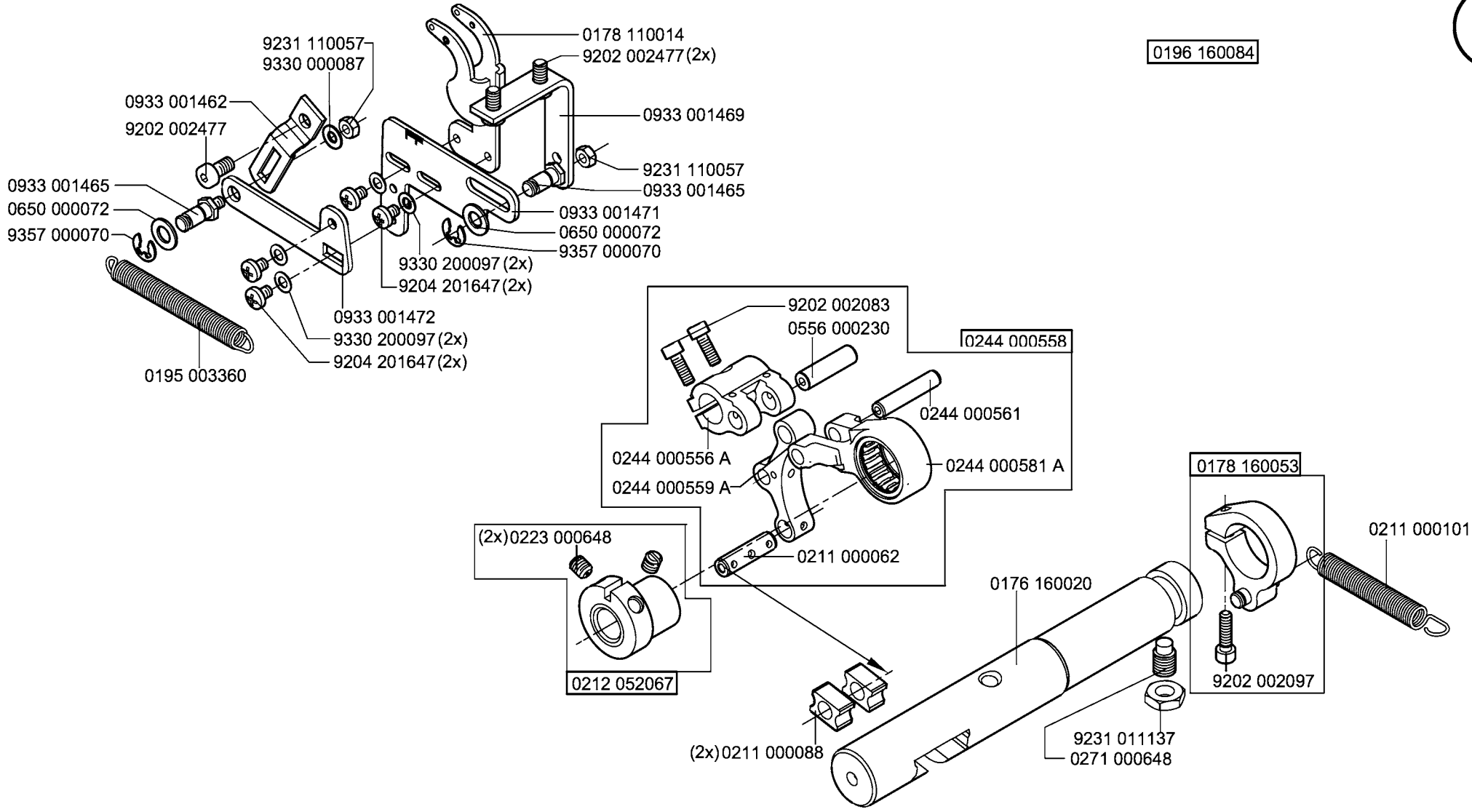

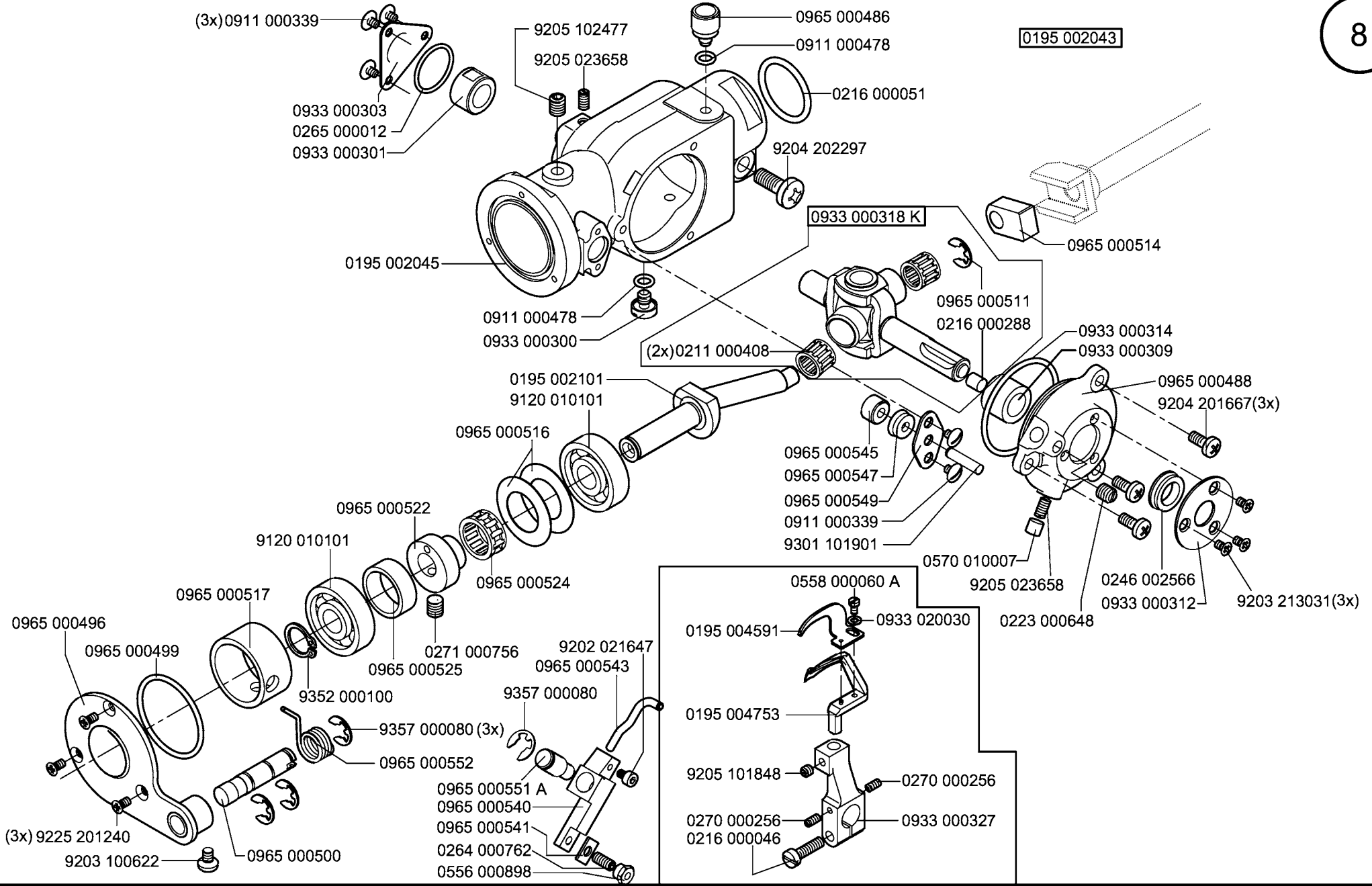

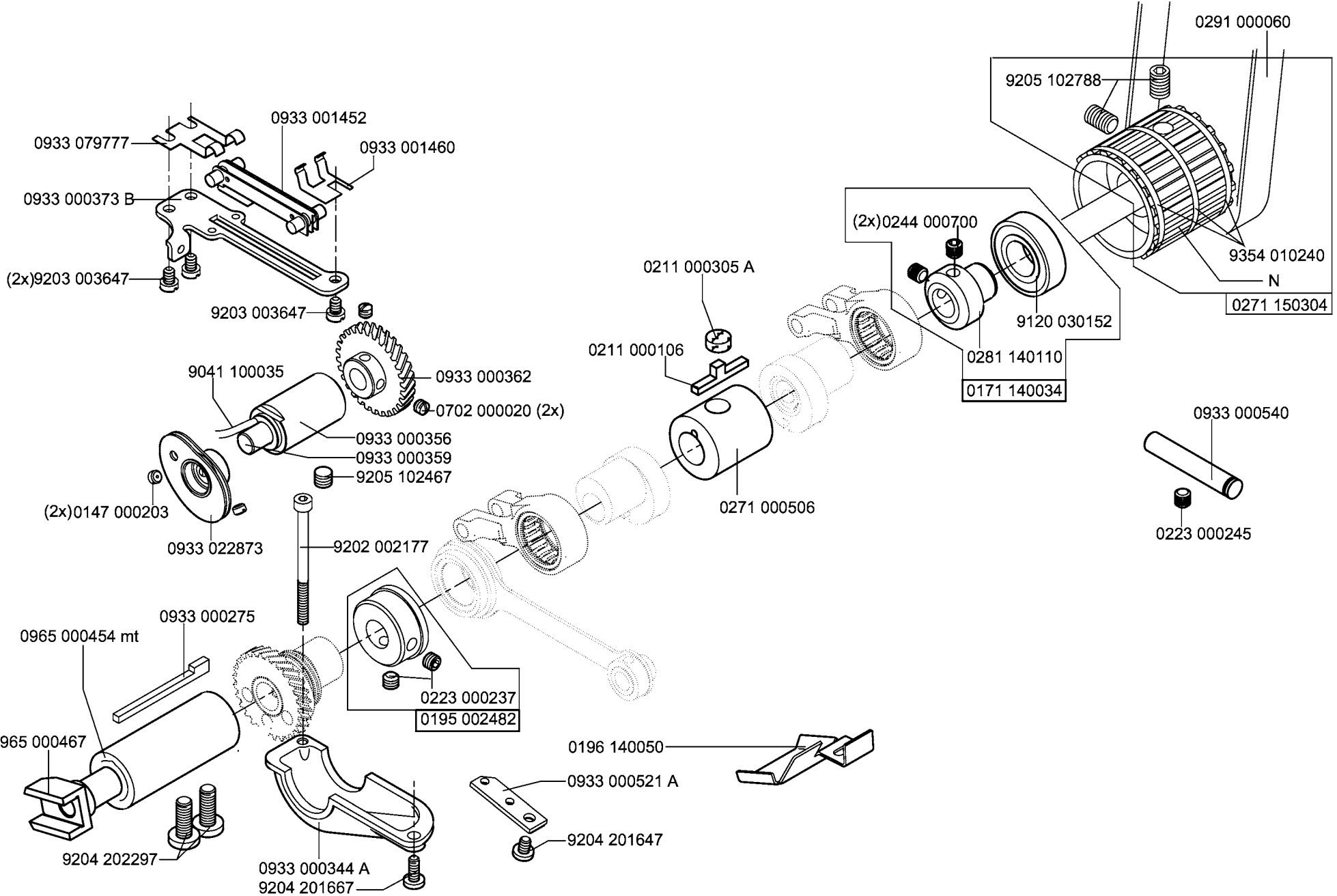

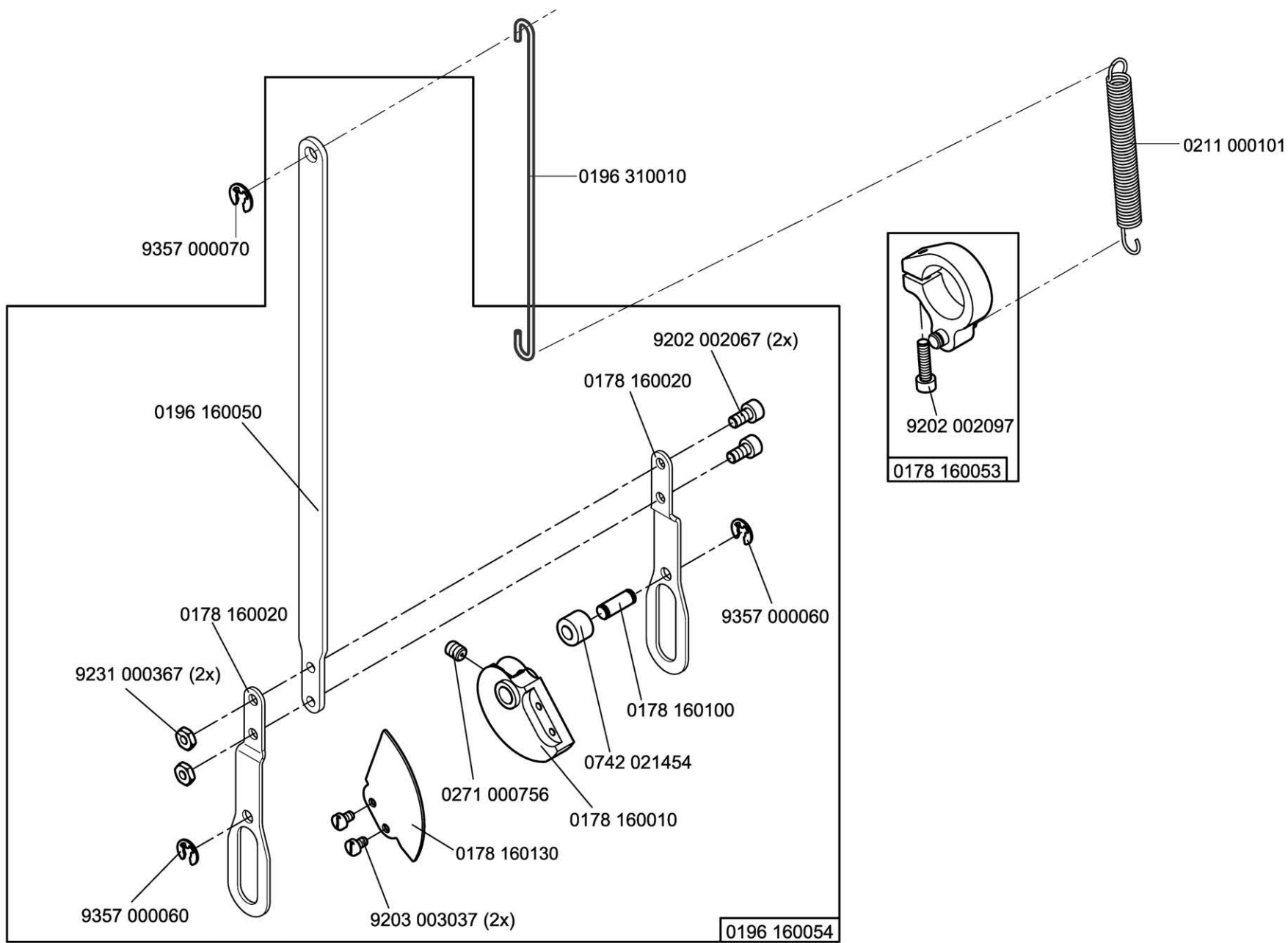

0196 160094

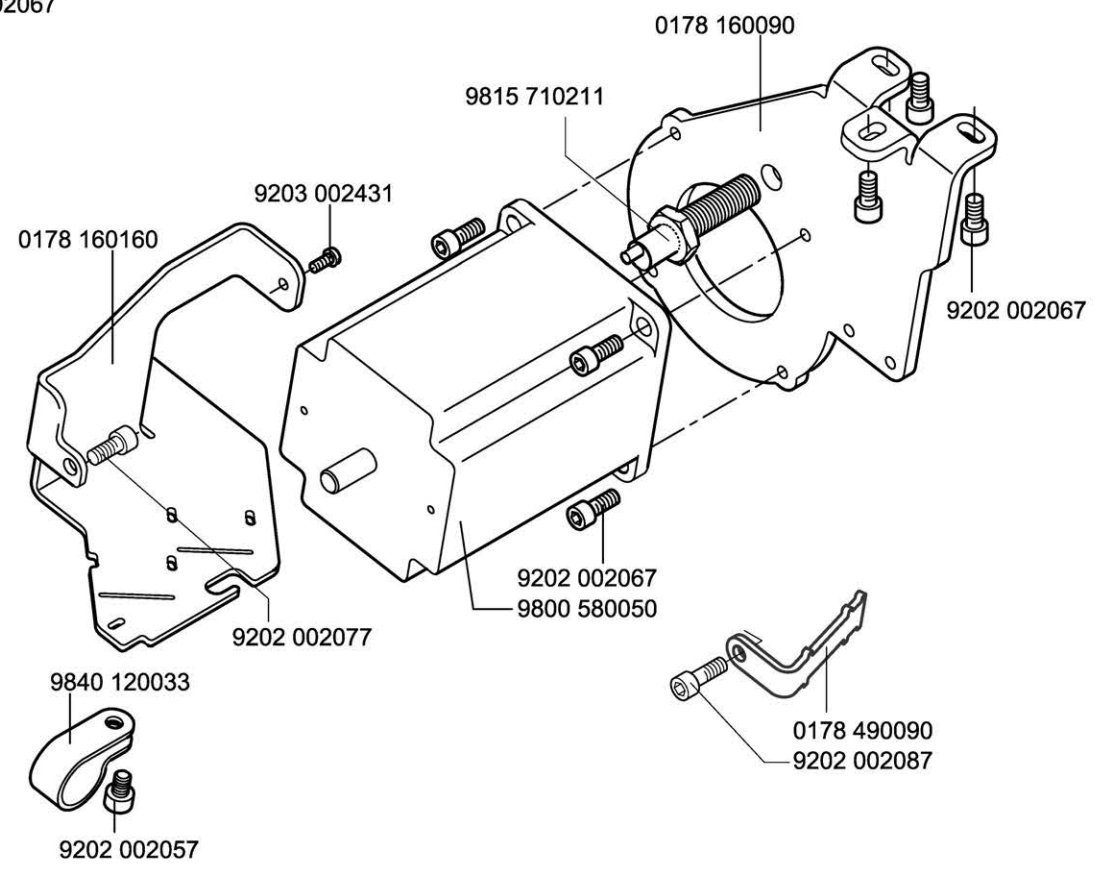
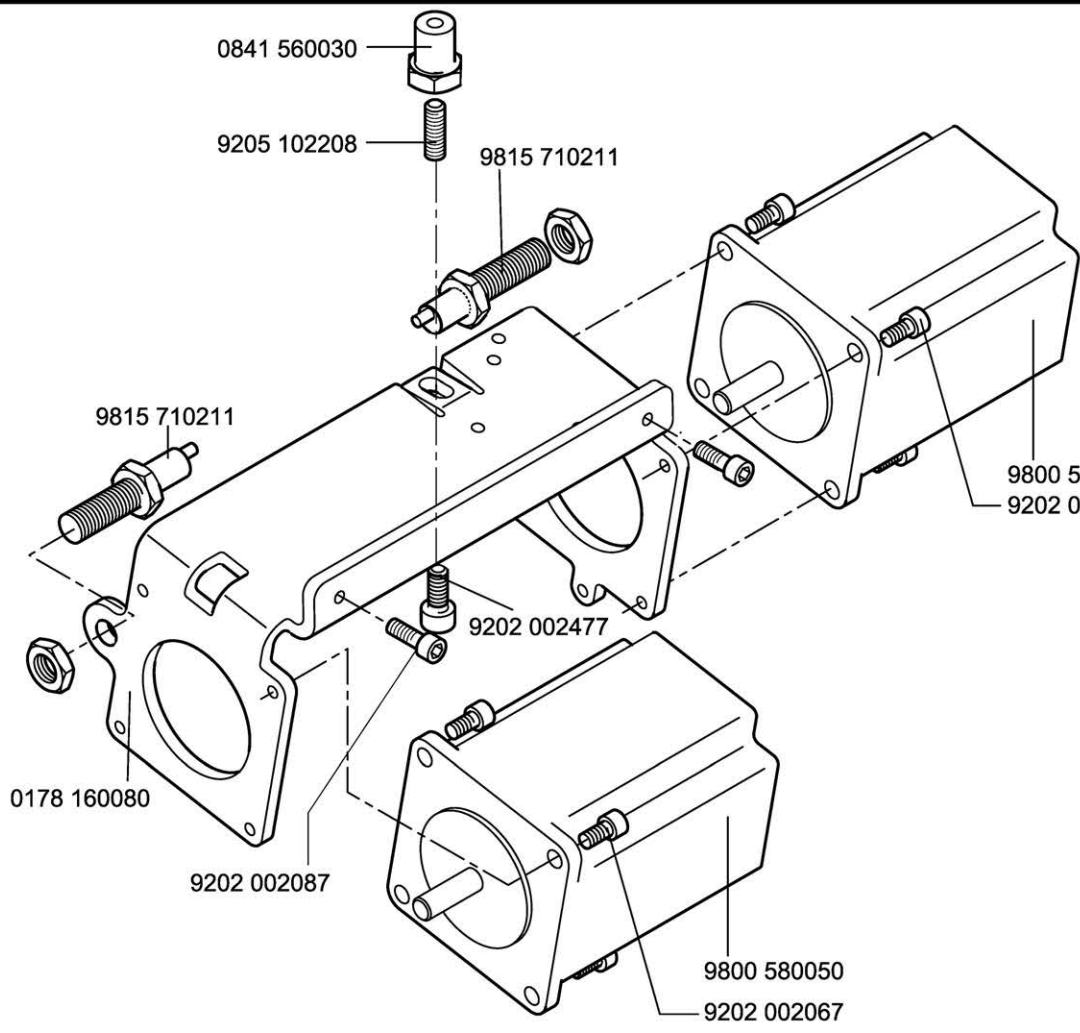

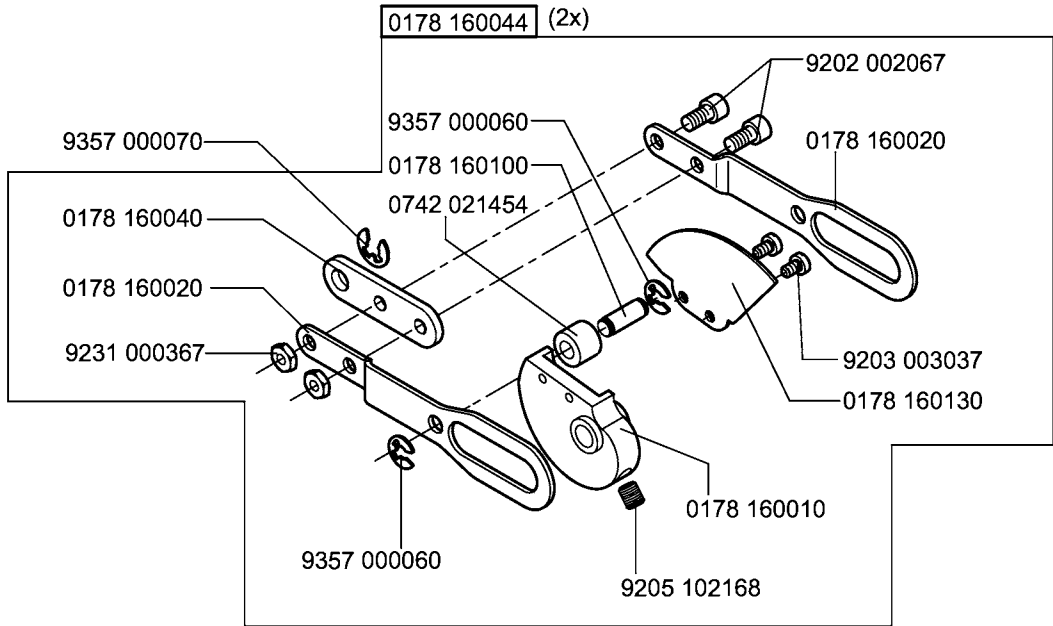

0195 100124

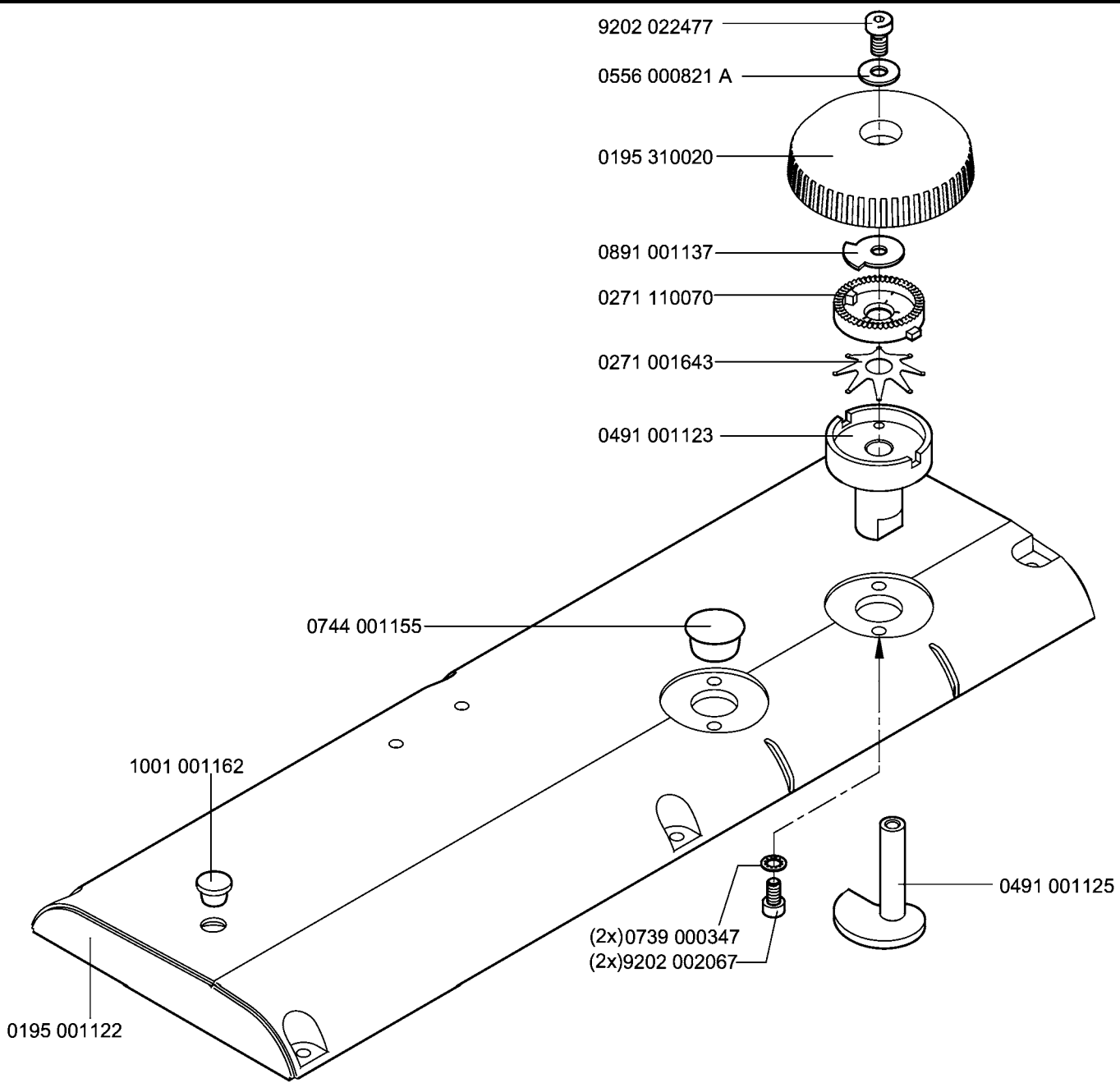

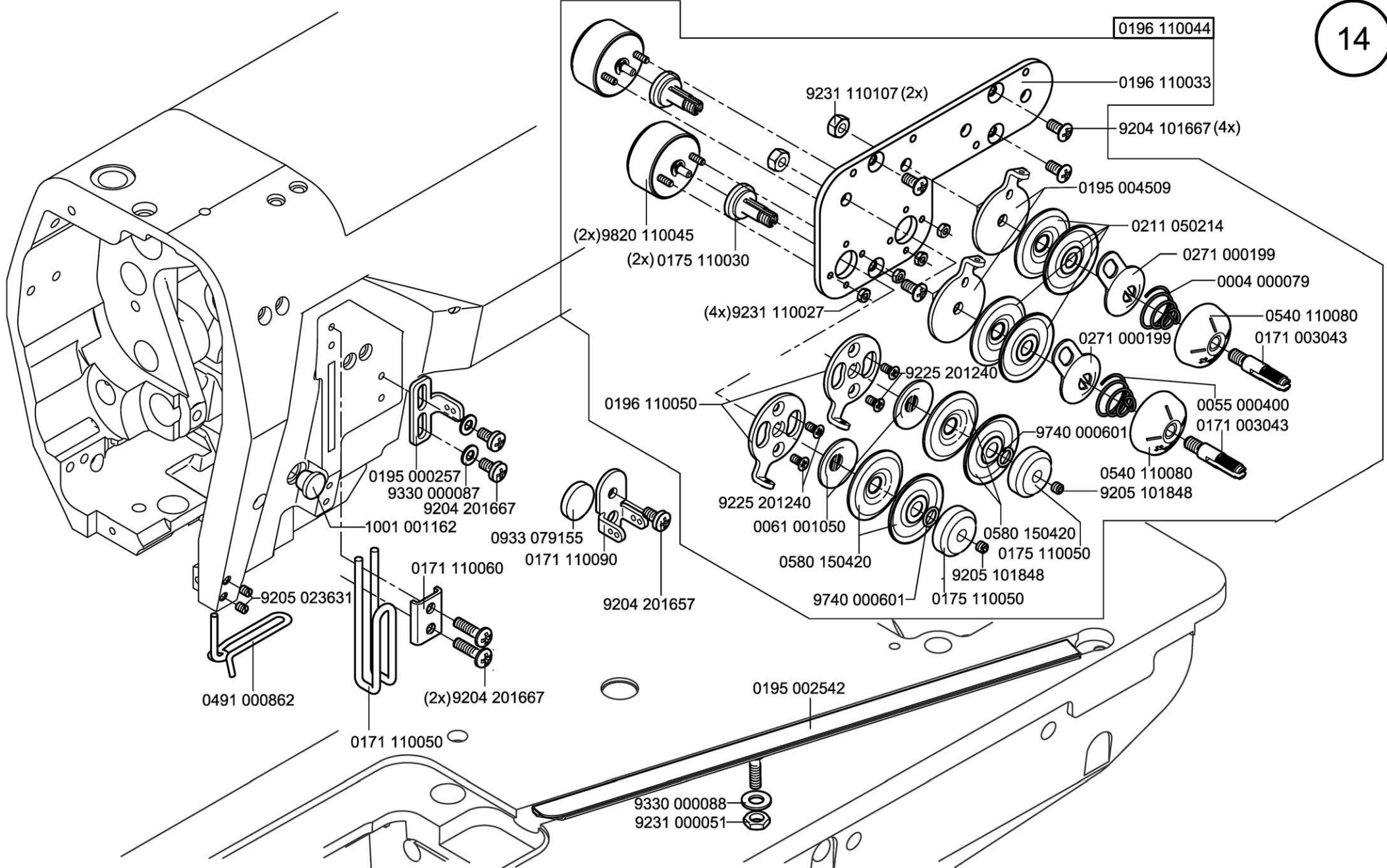

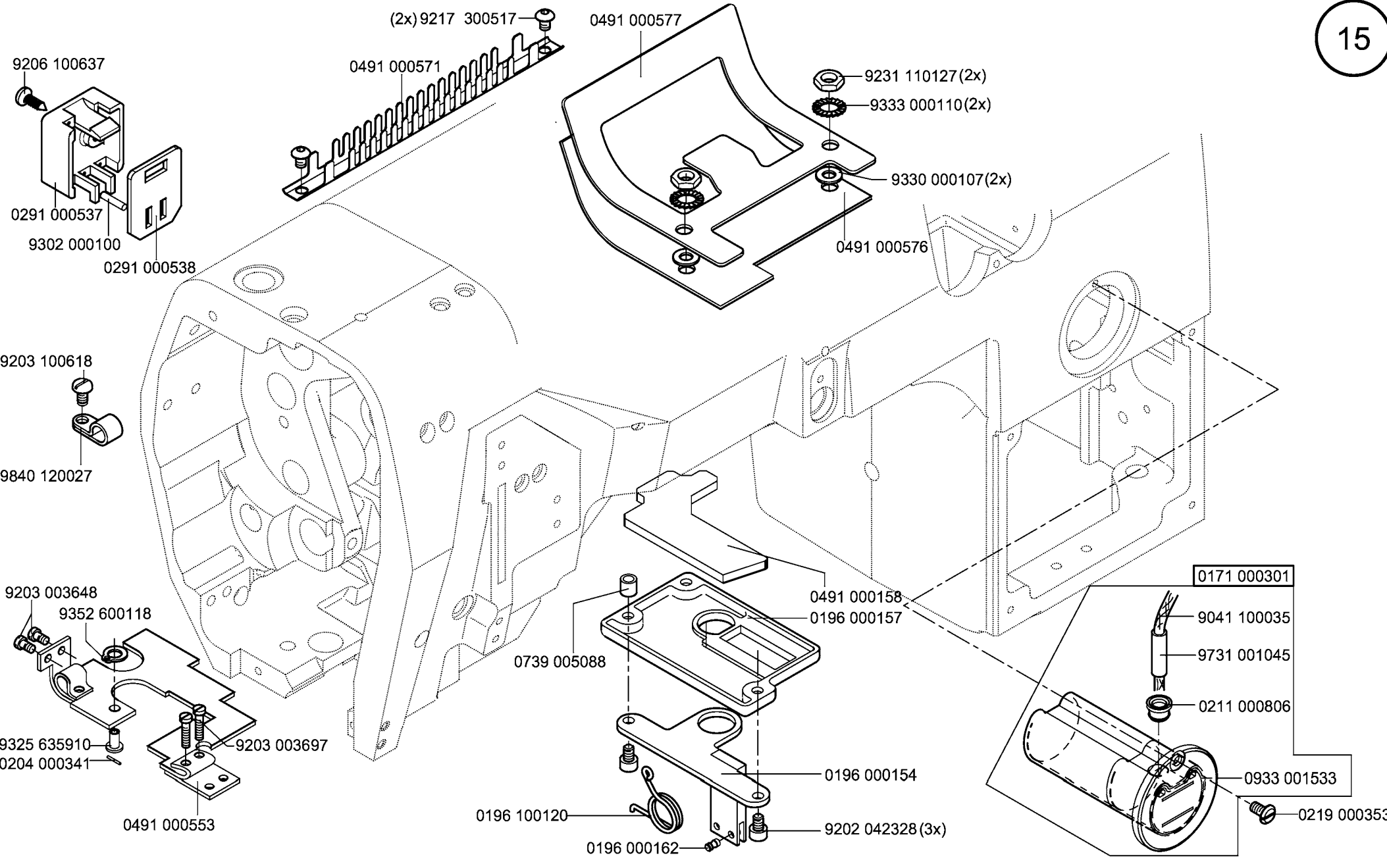

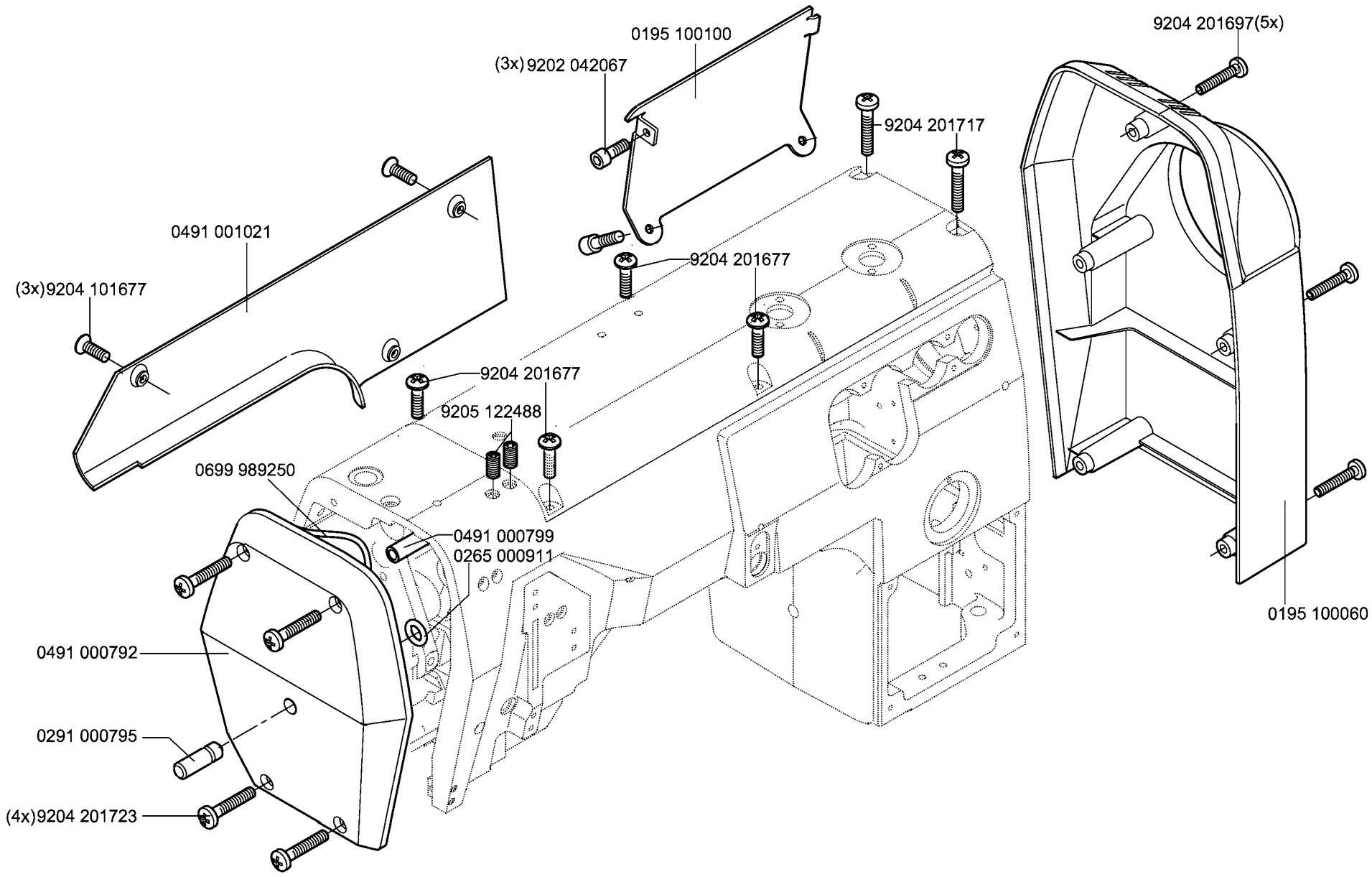

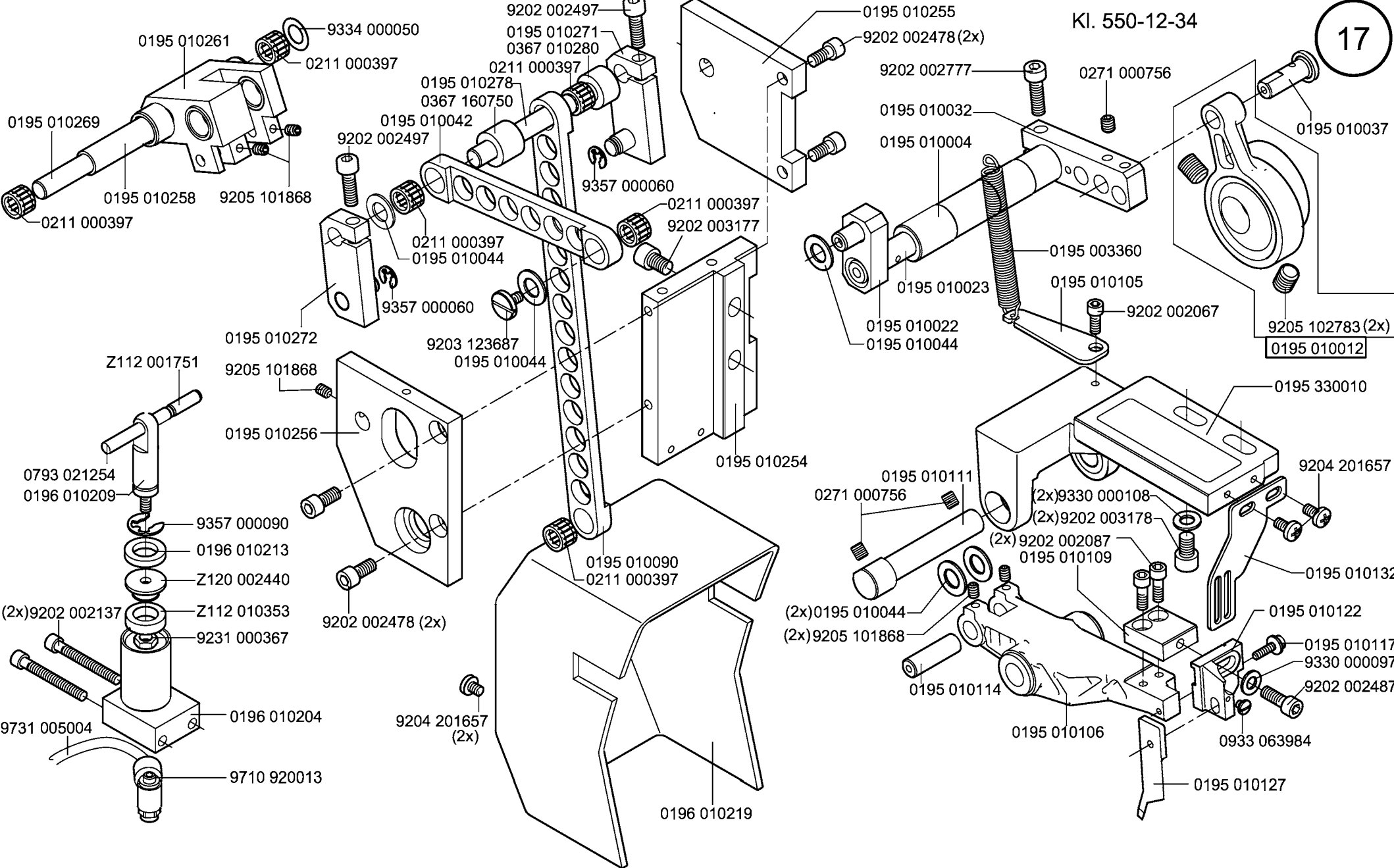

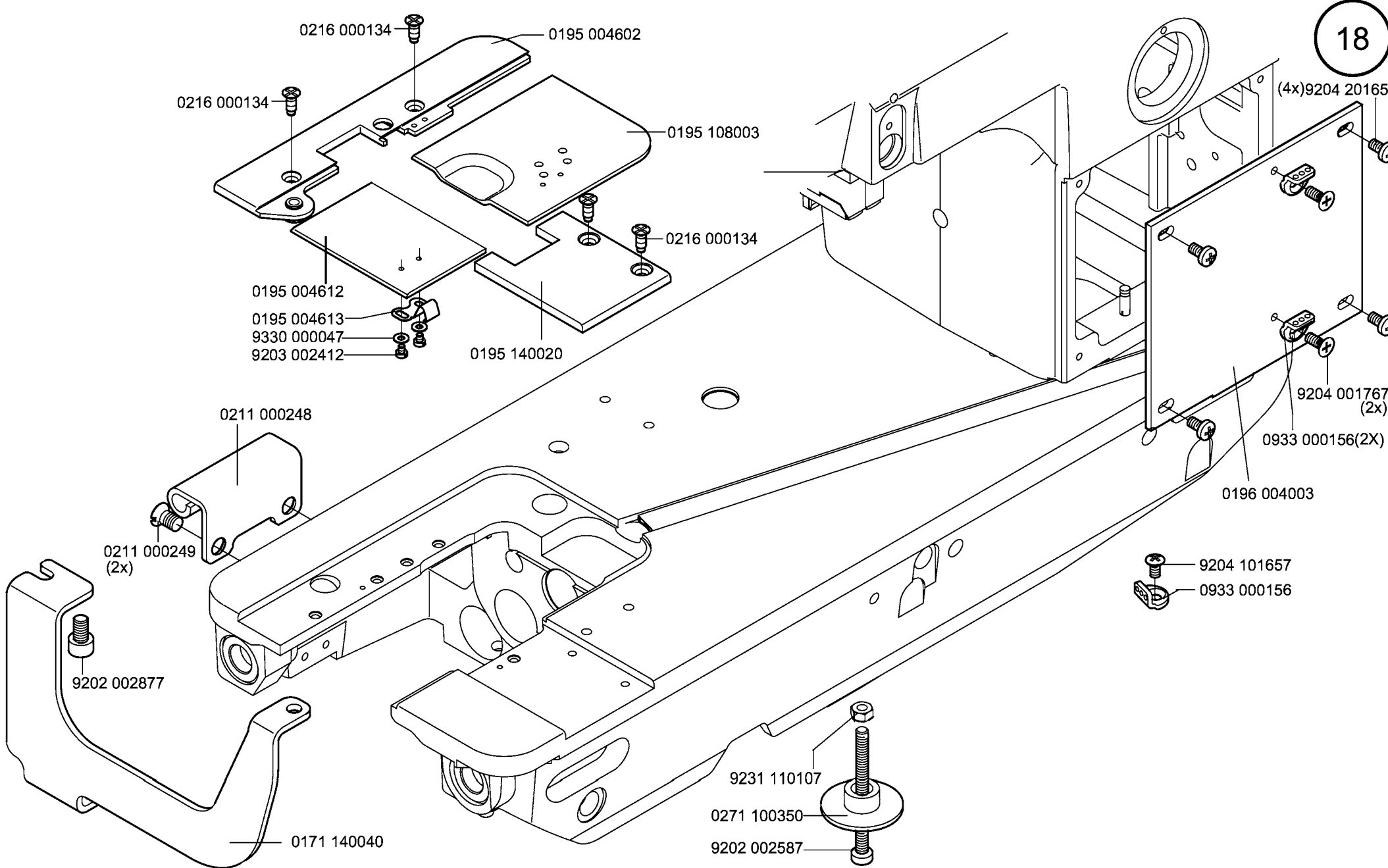

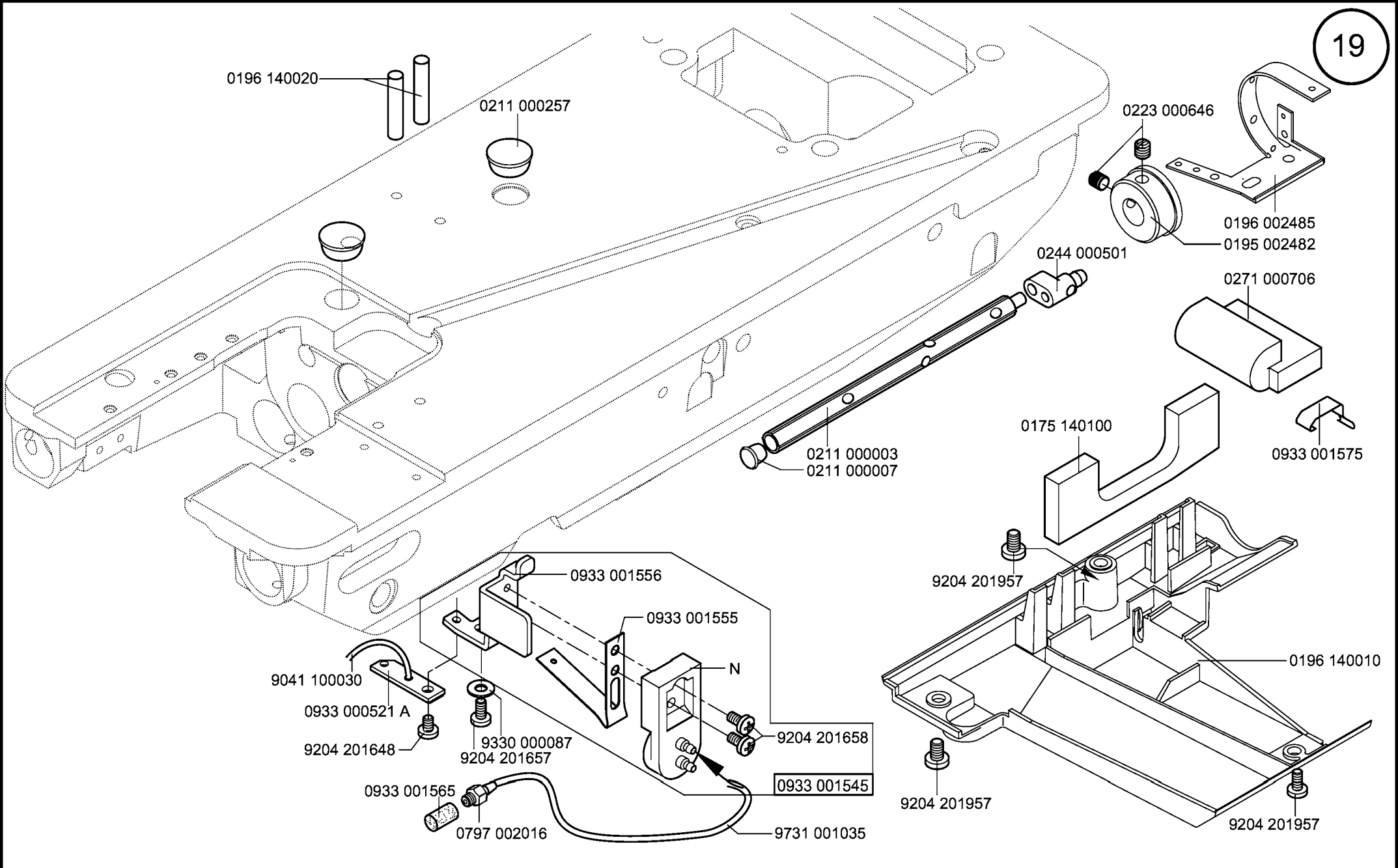

0195 590034

auf Wunsch  
on request

0APP 001469  
(2x) 9204 202067

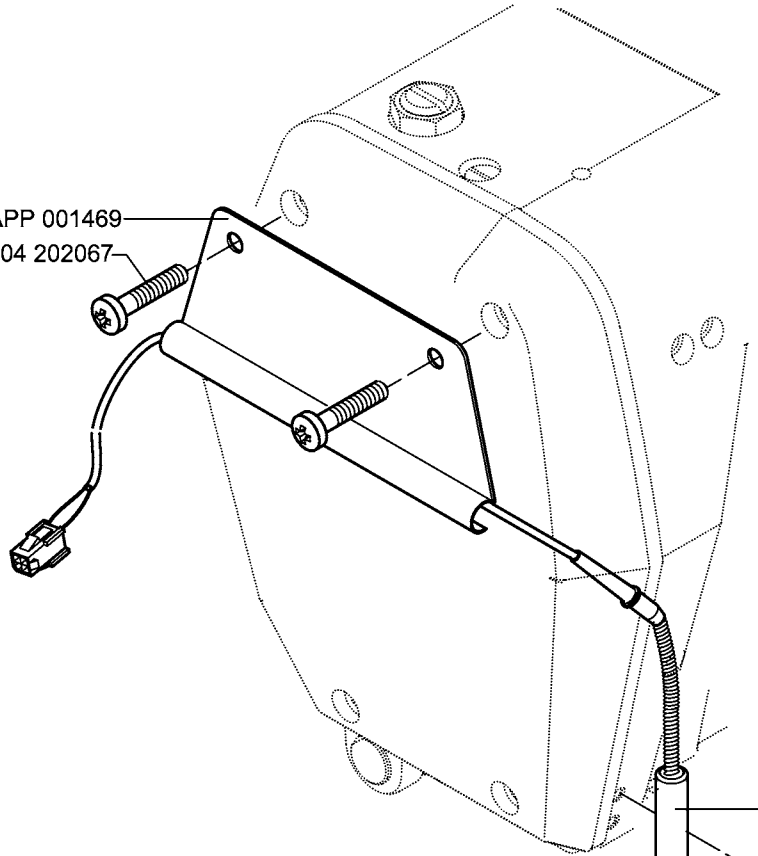

9202 002927

9202 002497

N900 003497

N900 002792

9822 560021

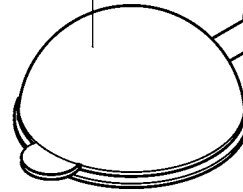

9822 560000

0195 490010

9330 000087

9204 201647

9840 120032

9850 001089

auf Wunsch  
on request

9840 120003

9840 123003

9840 133012

9840 135012

(2x) 9330 000087

(2x) 9207 170437

9840 121001

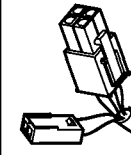

9850 001083

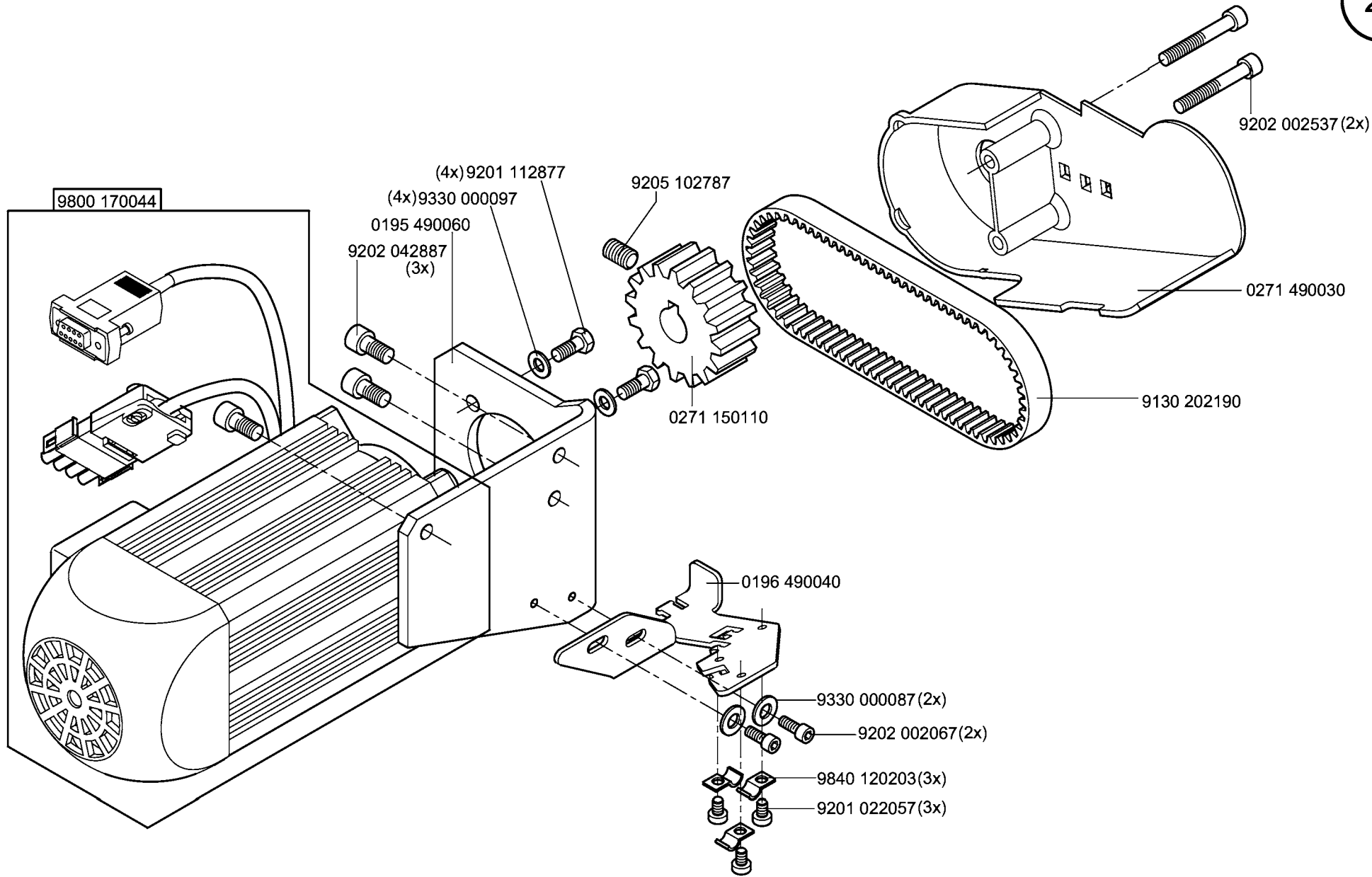

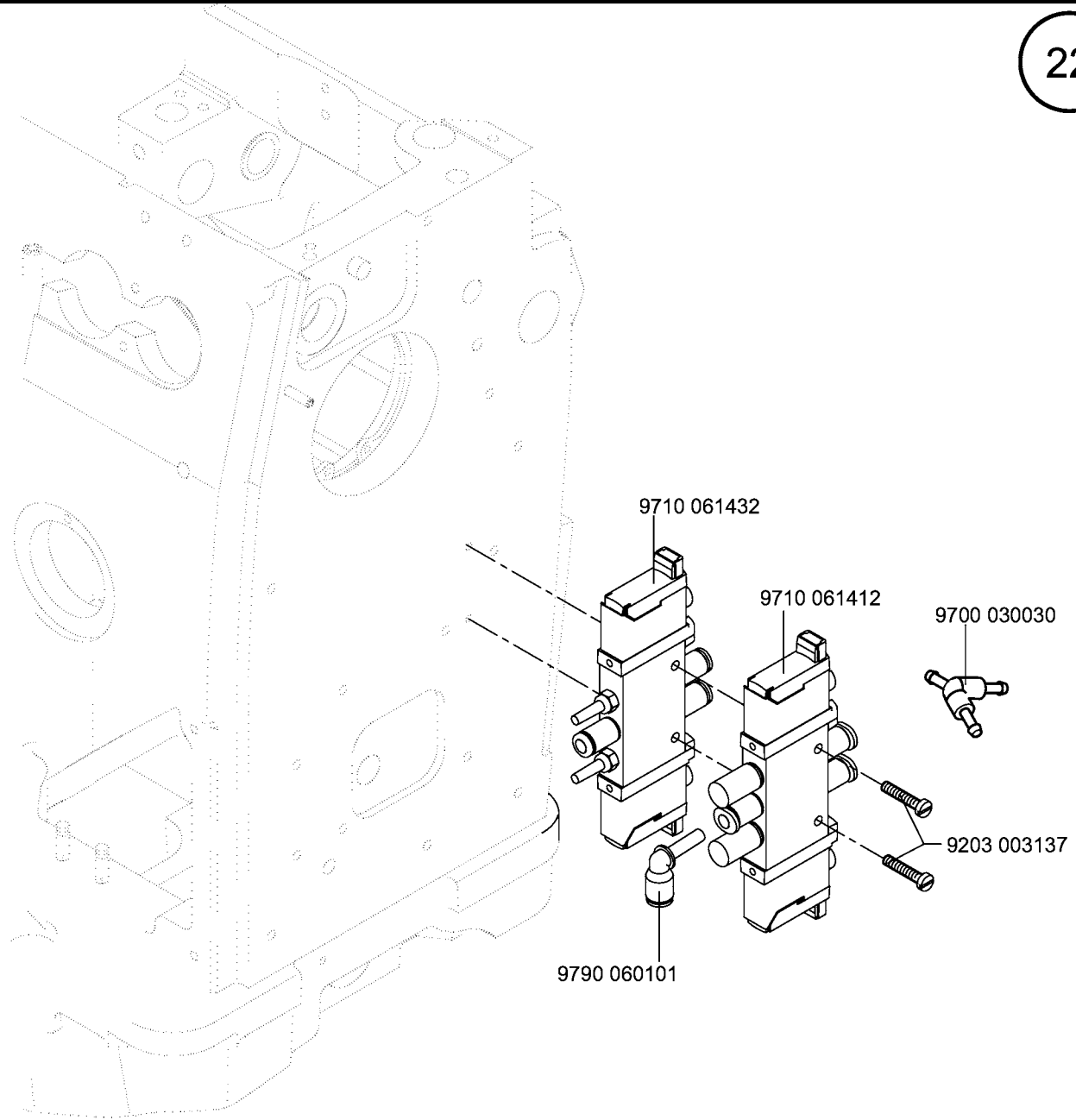

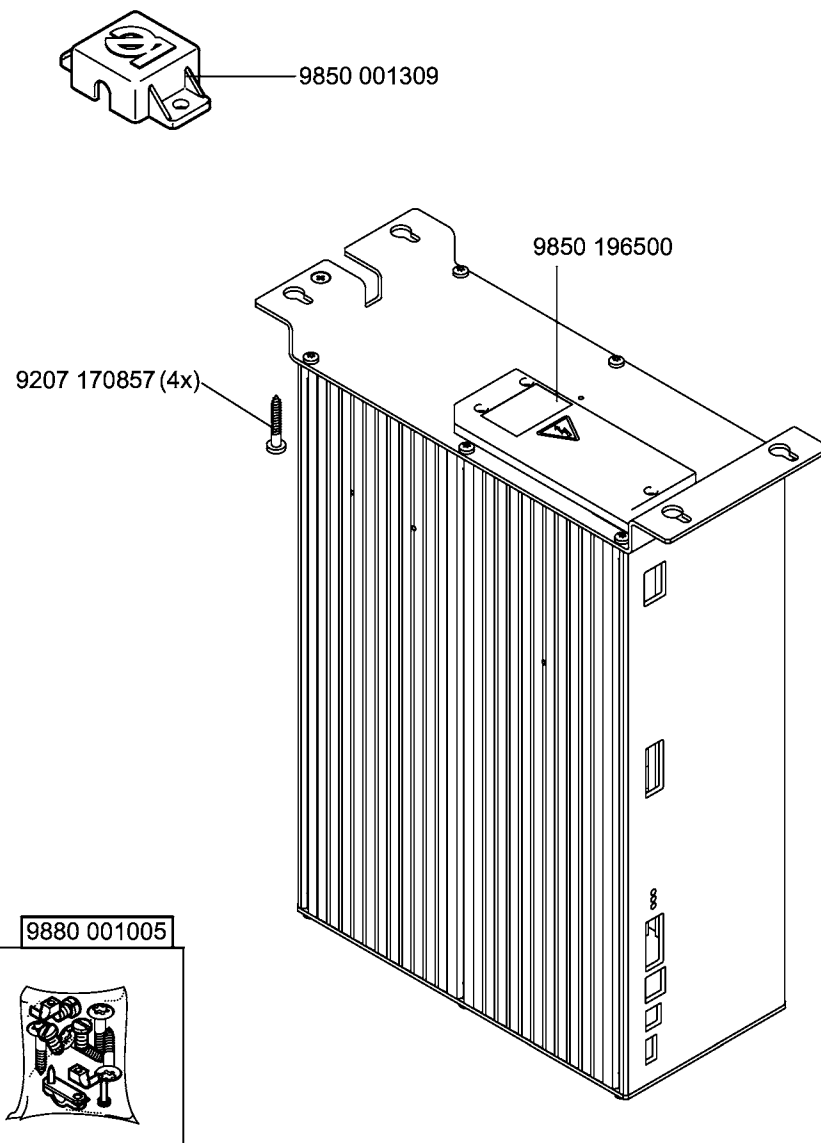
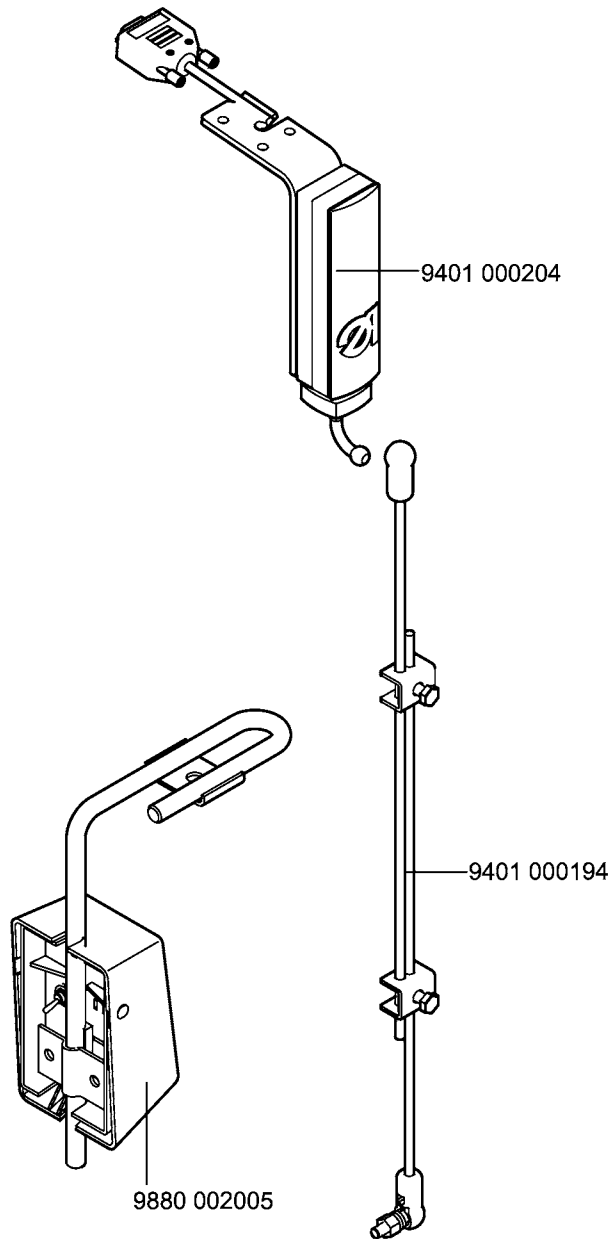

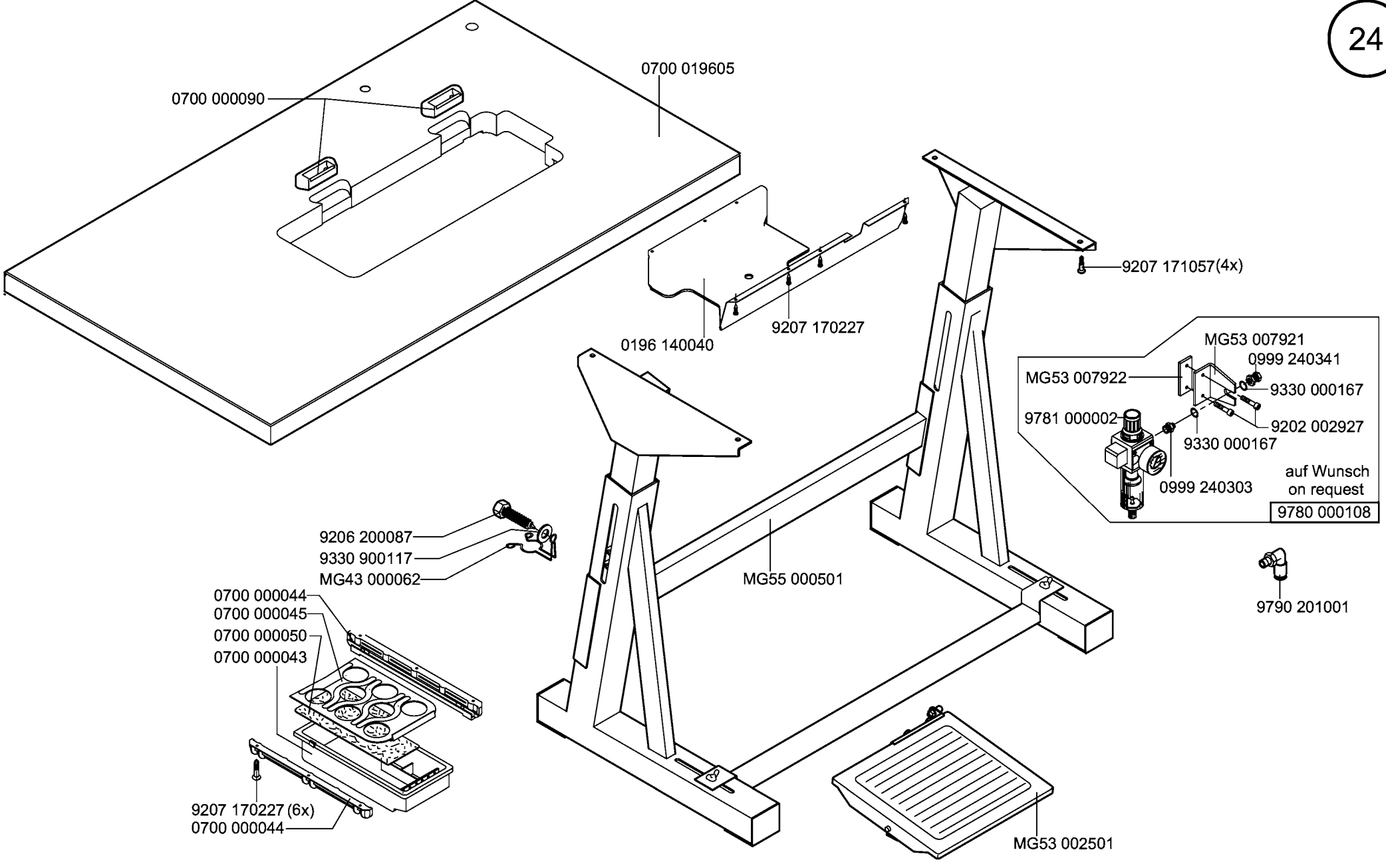

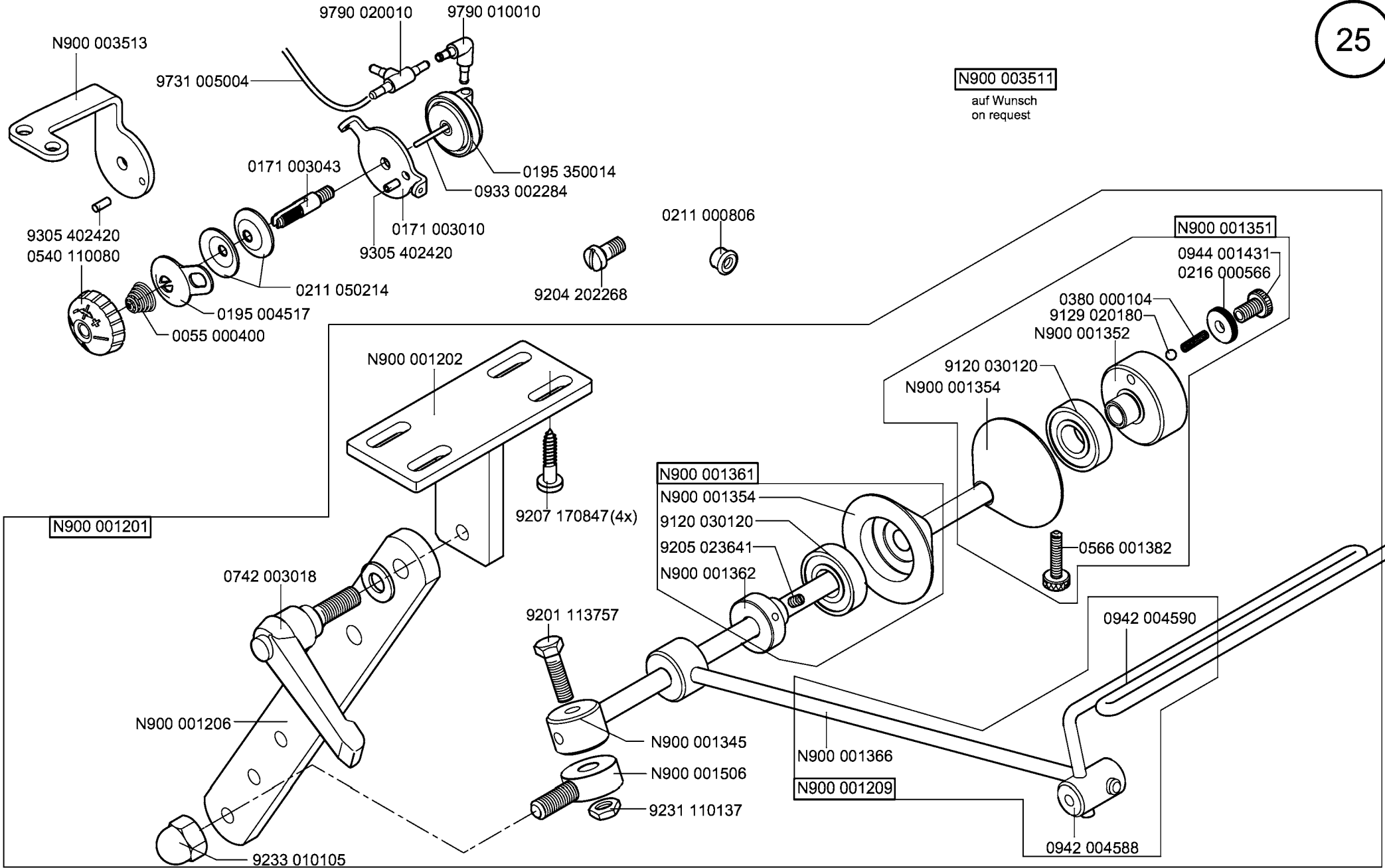

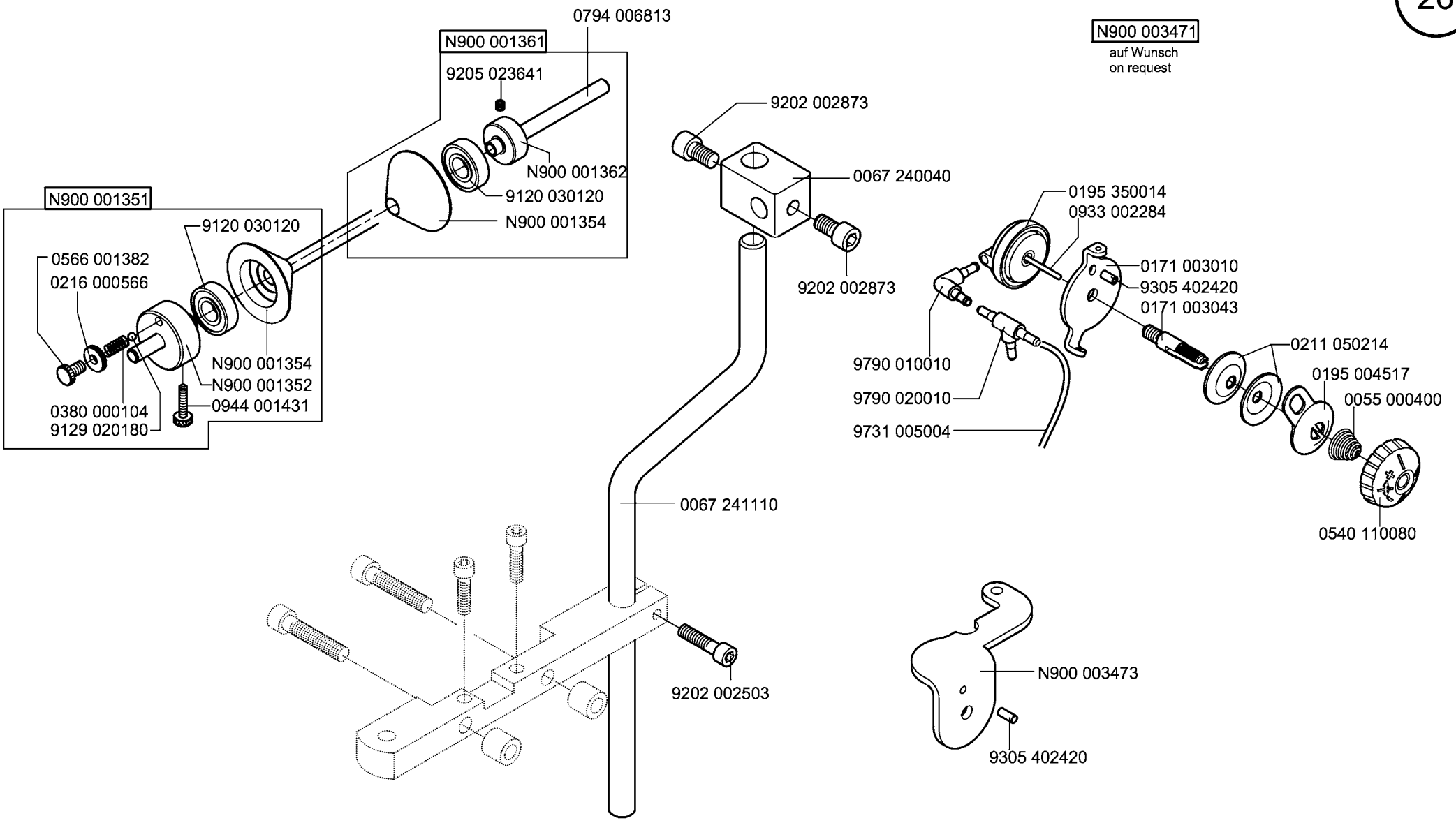

N900 003471  
auf Wunsch  
on request

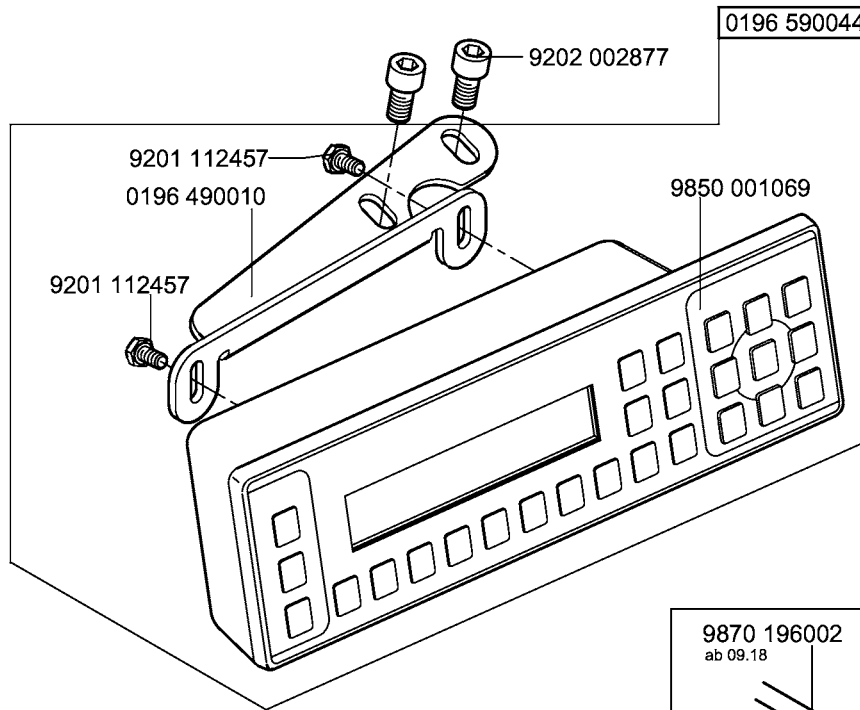

0196 160094

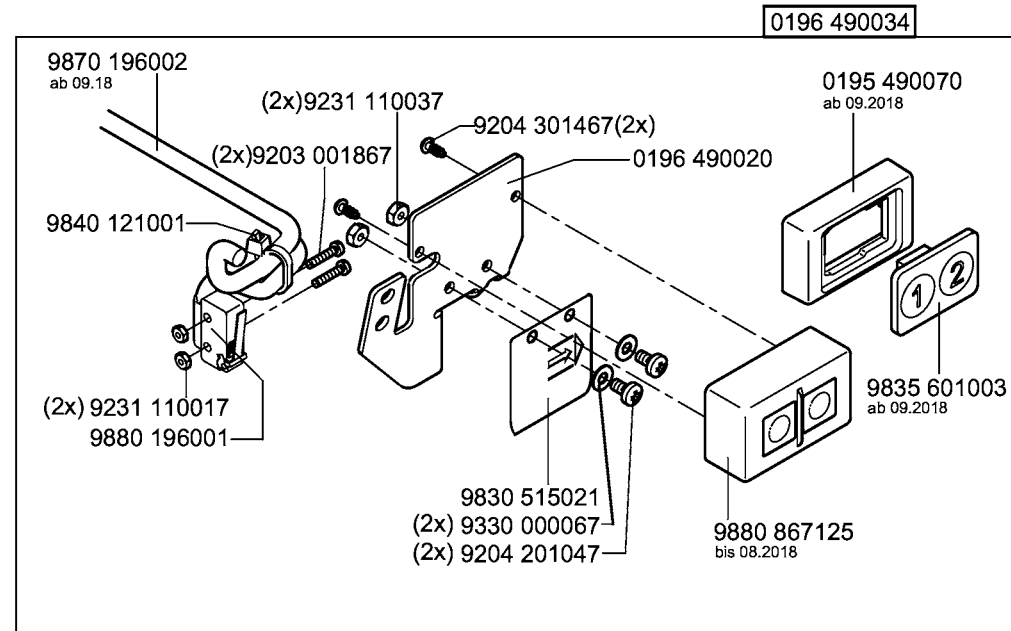

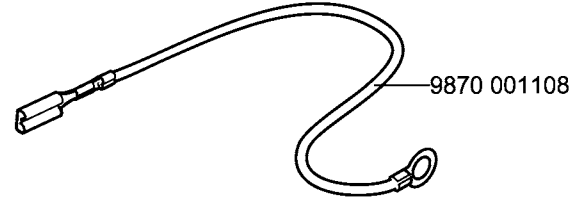
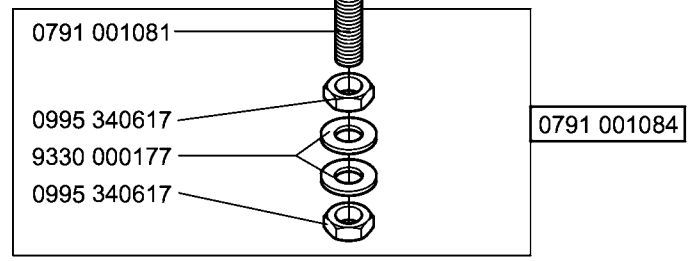
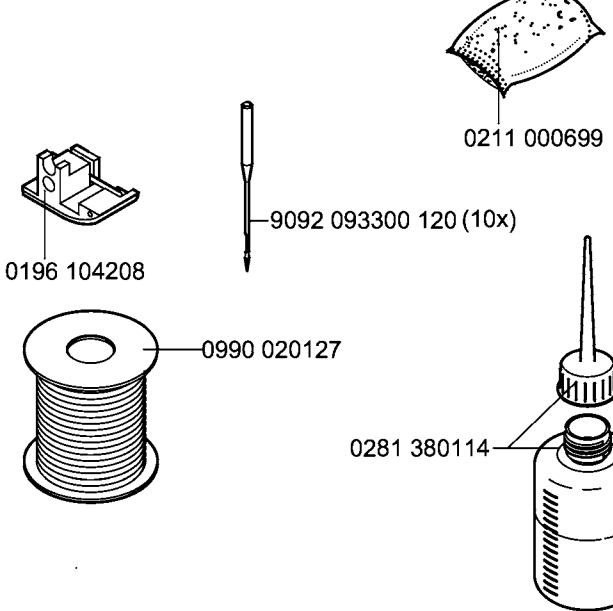
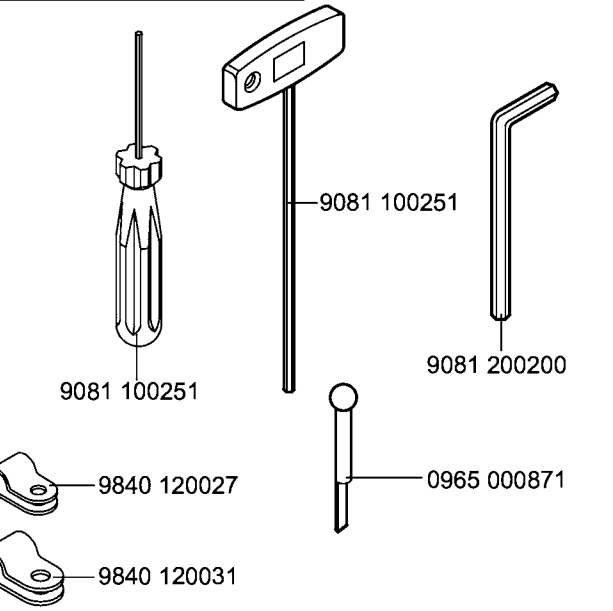
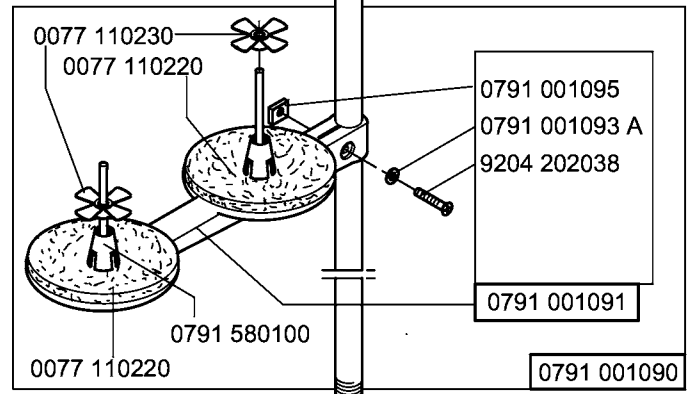
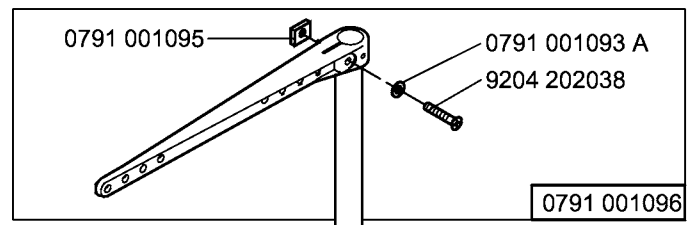
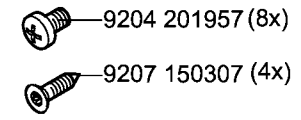
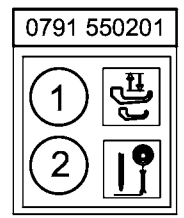
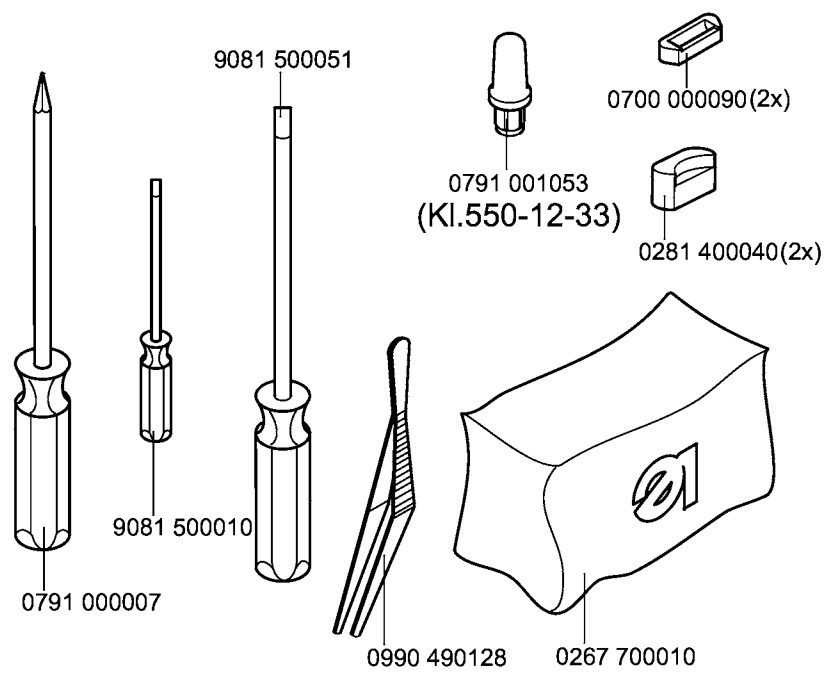
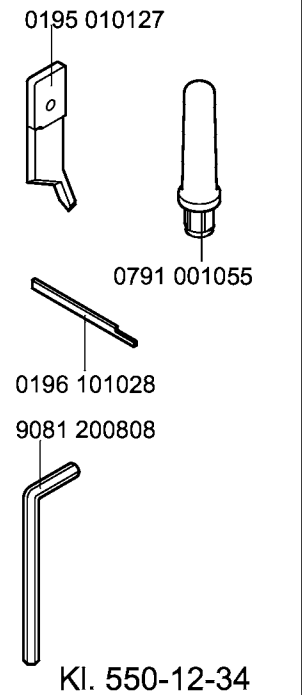

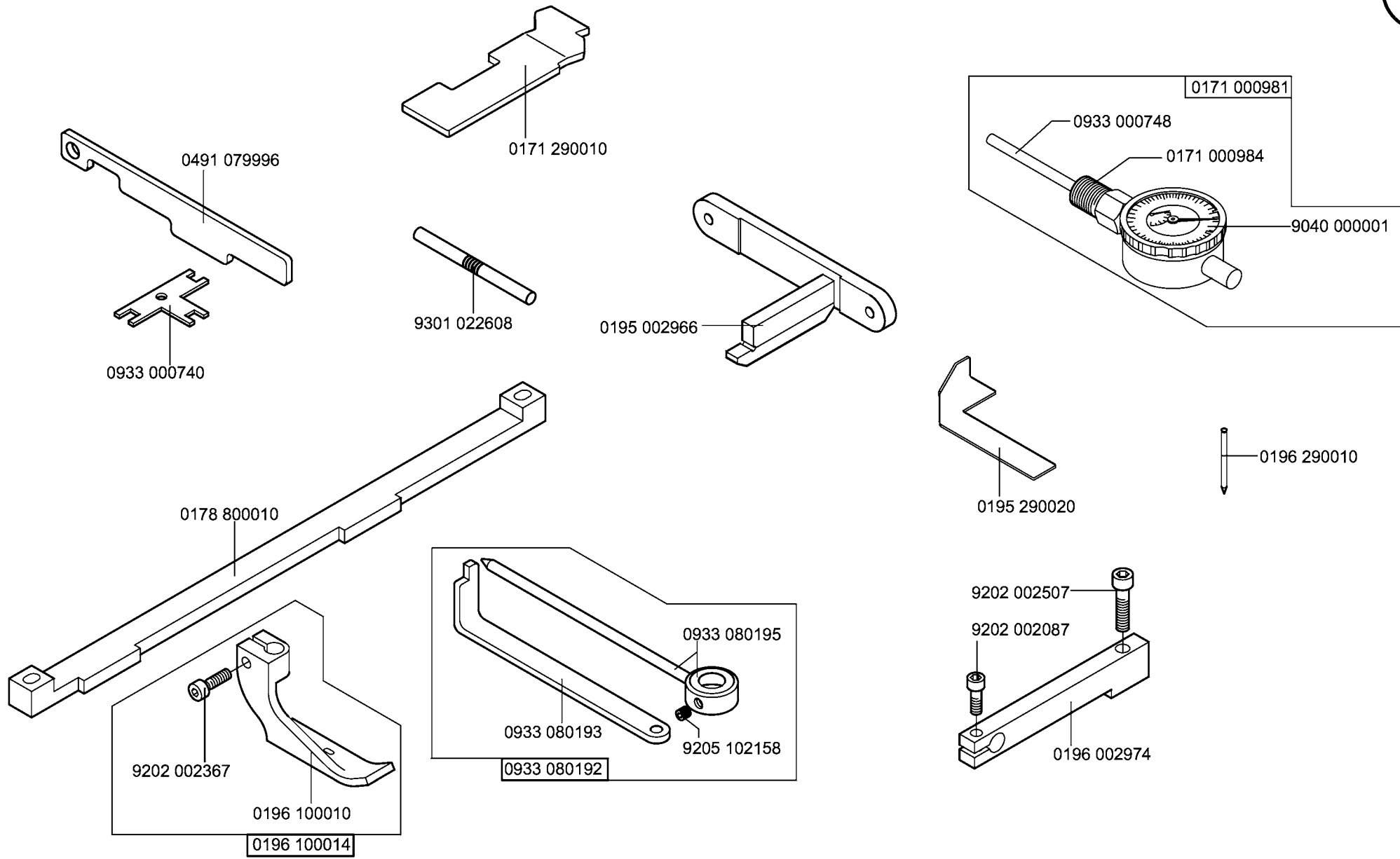

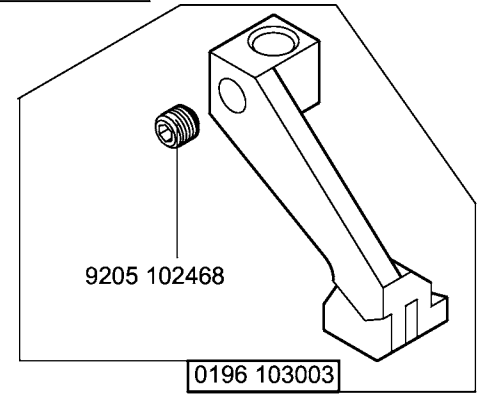
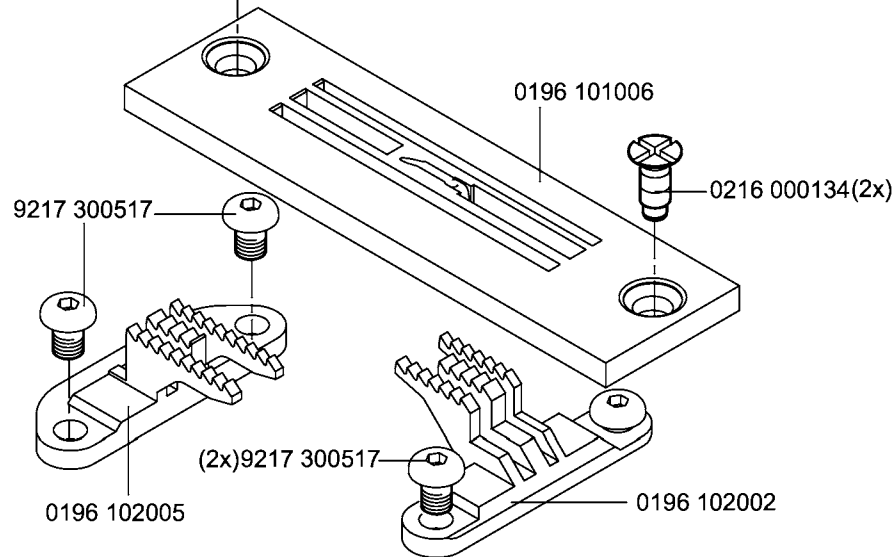
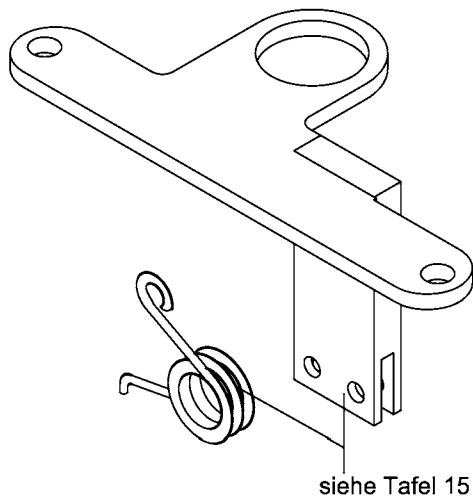
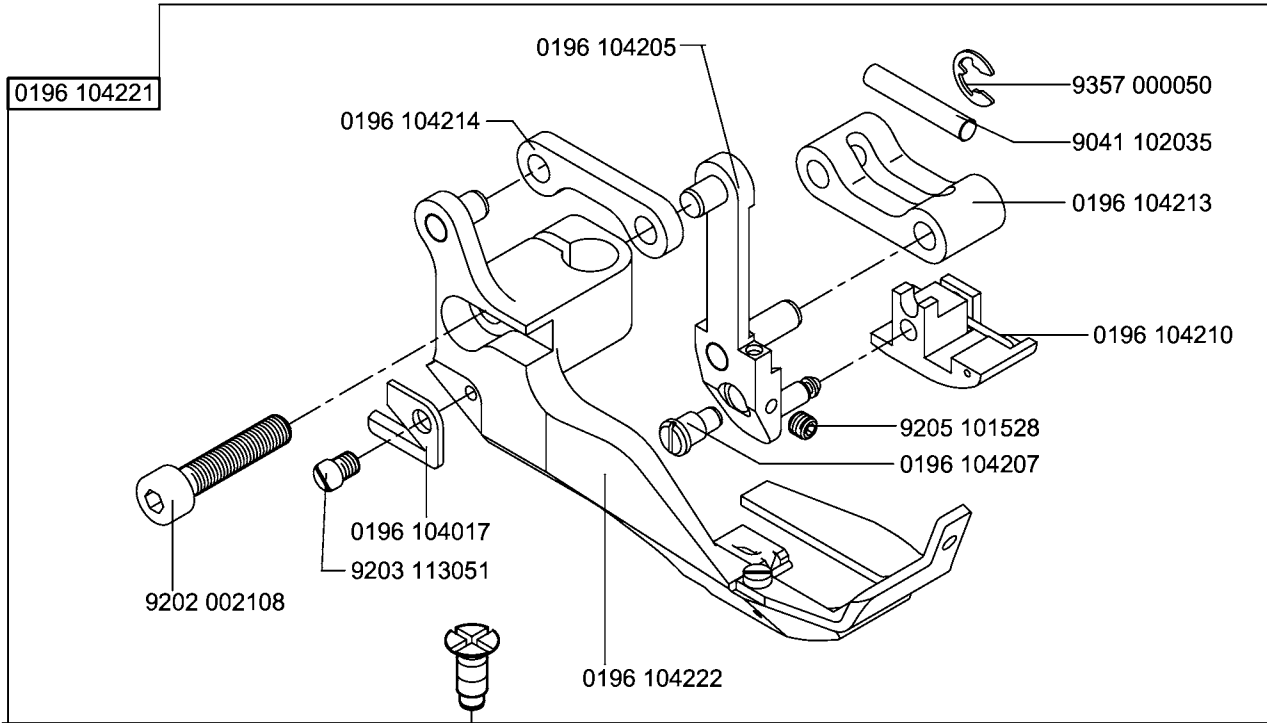

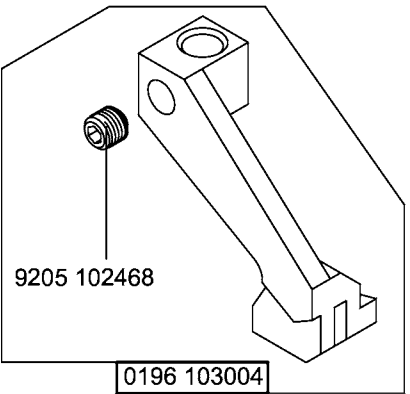
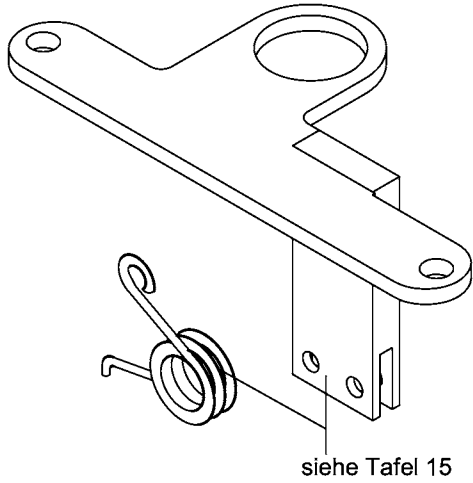
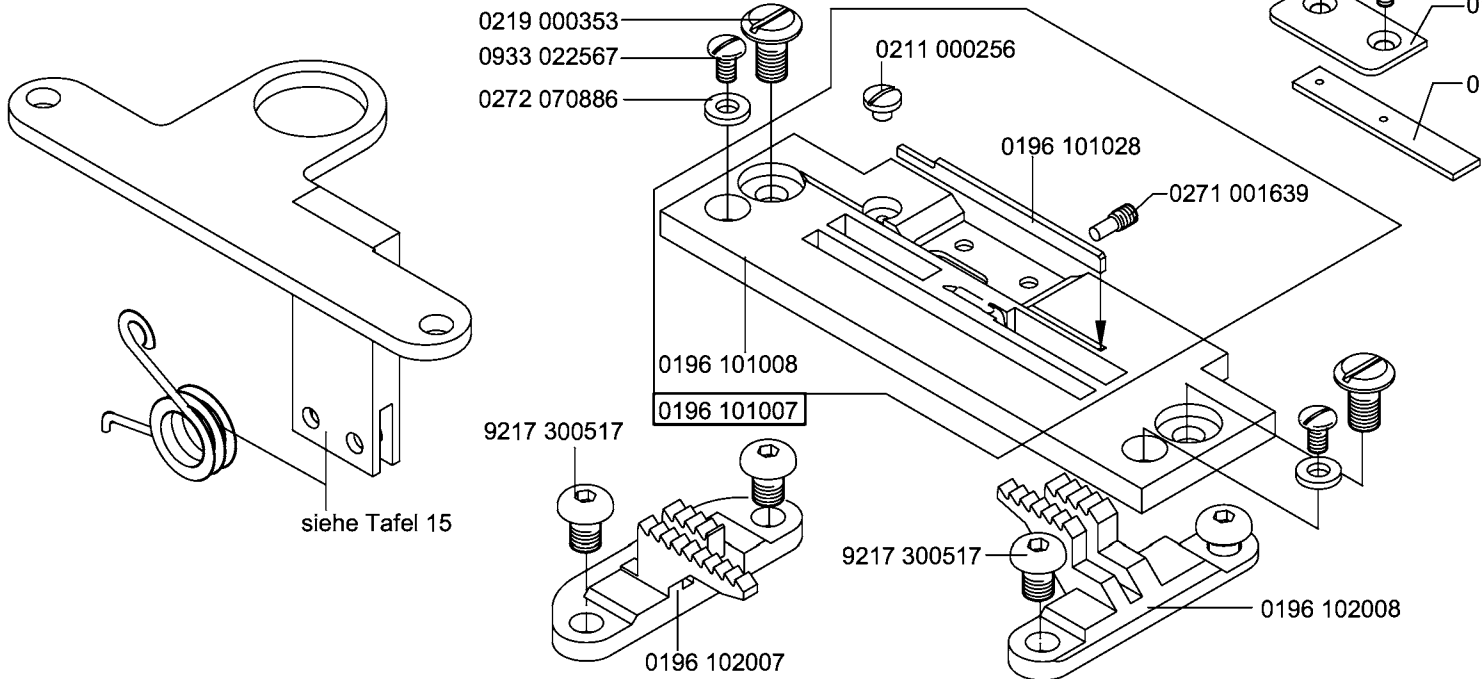
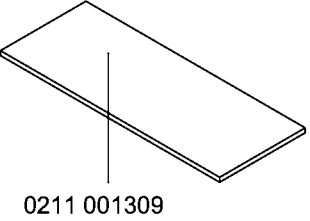
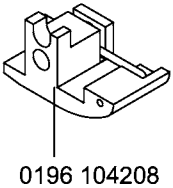
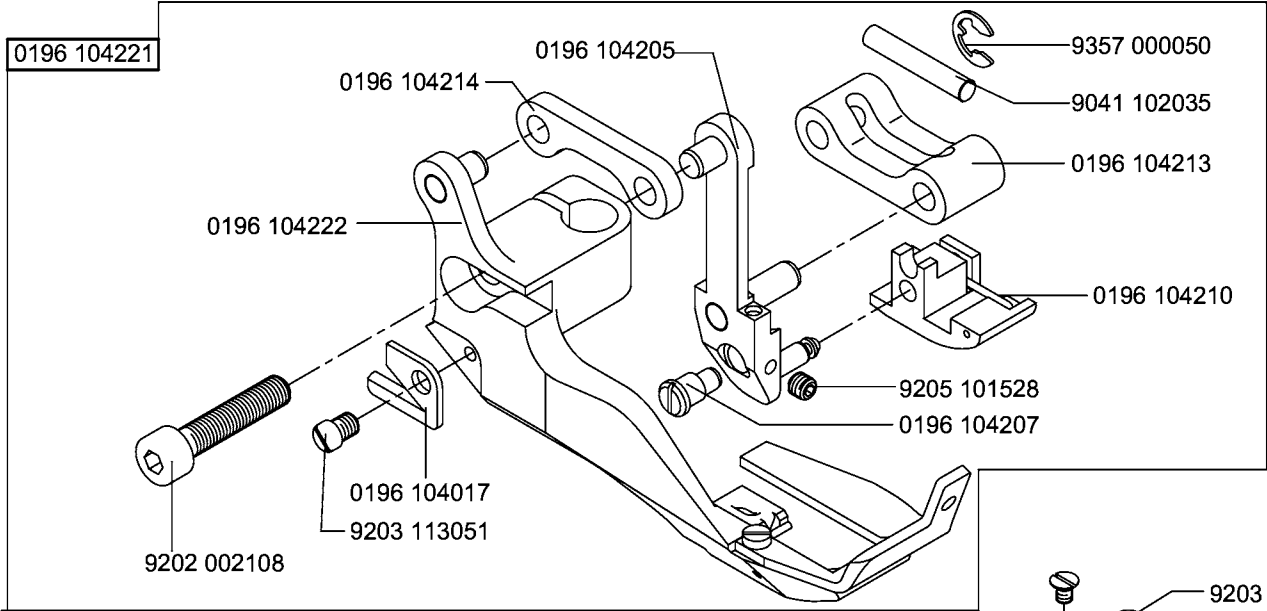

N900 040026

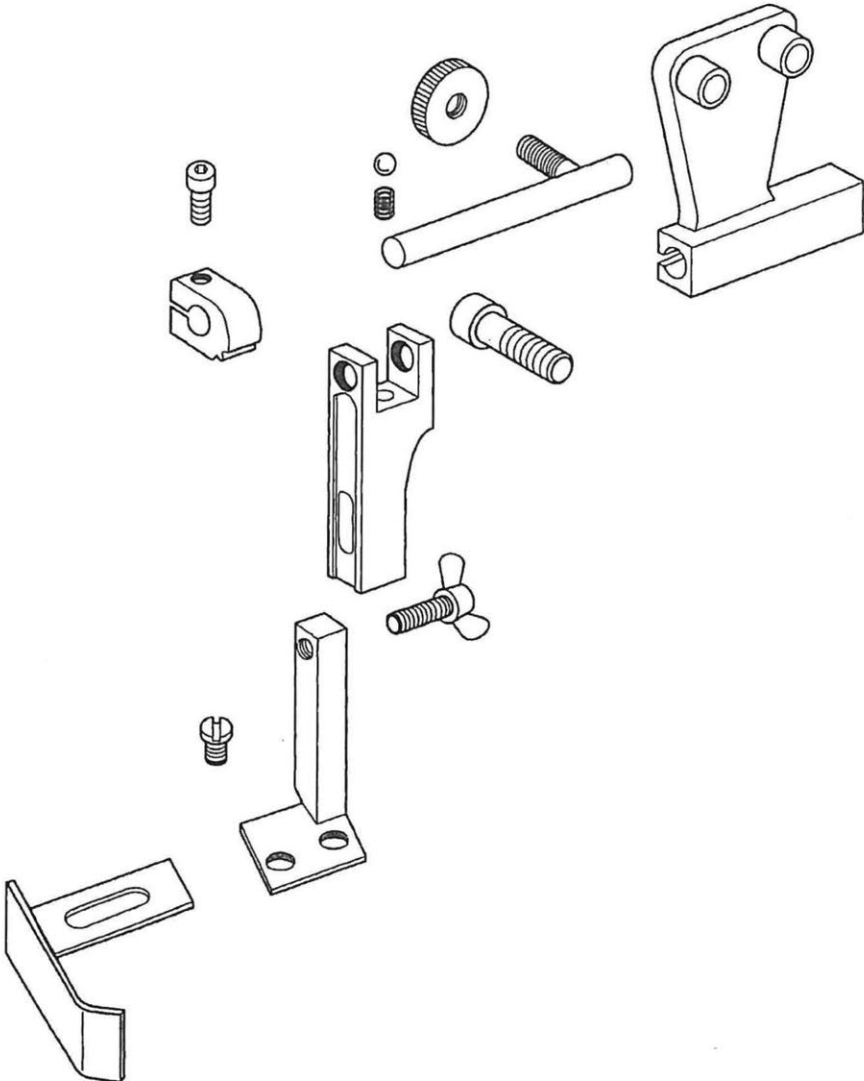

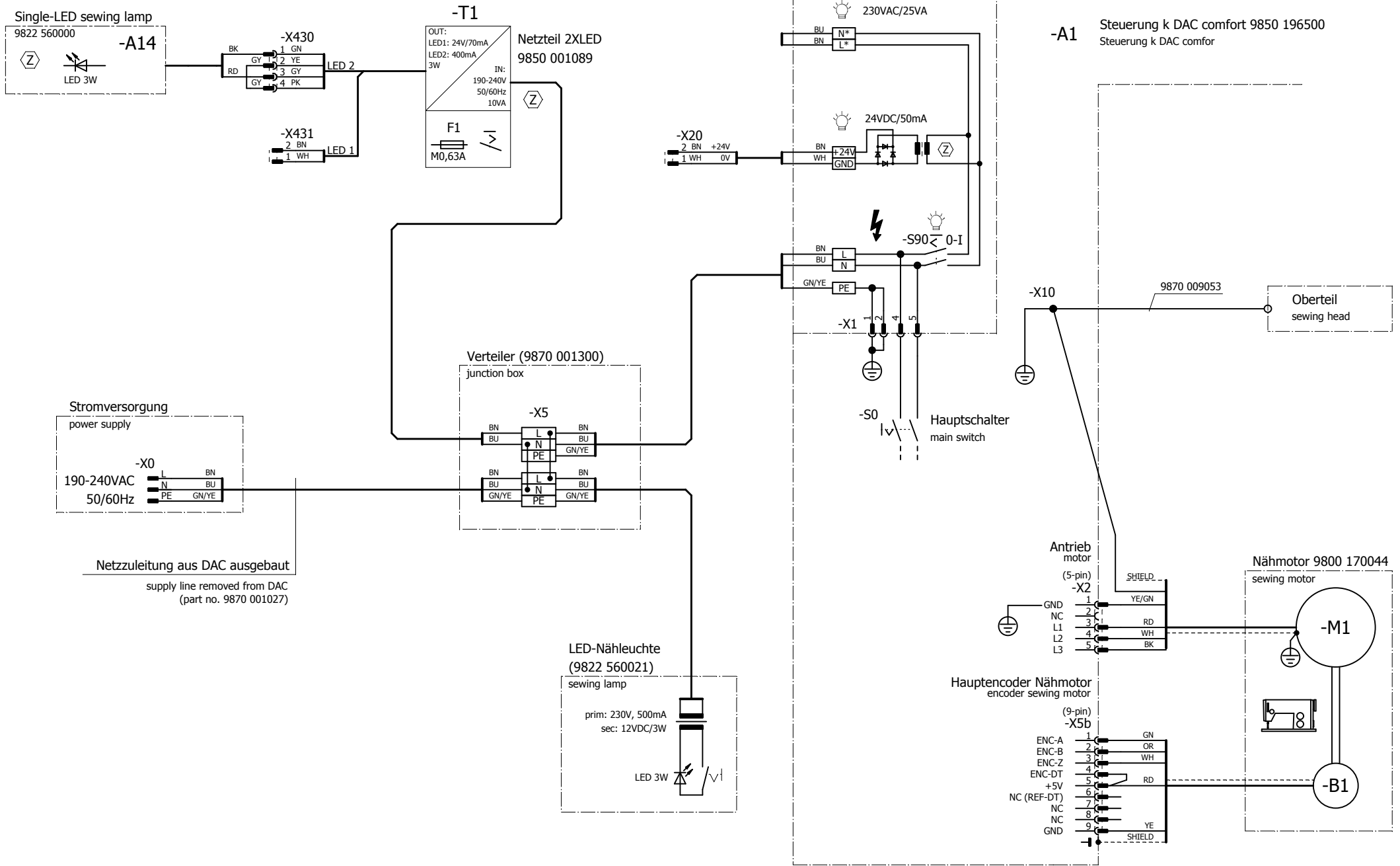

Zusatzausstattung  
Optional equipment

c		Datum	26.01.2018
b		Bearb.	Görzen
a		Geprüft	
Änd.	Datum	Name	Norm



Teilfamilie	8630
Freigabe	0016/17

Kl. 196 (550-12-33/34)

**Bauschaltplan**  
**9890 196000 B**

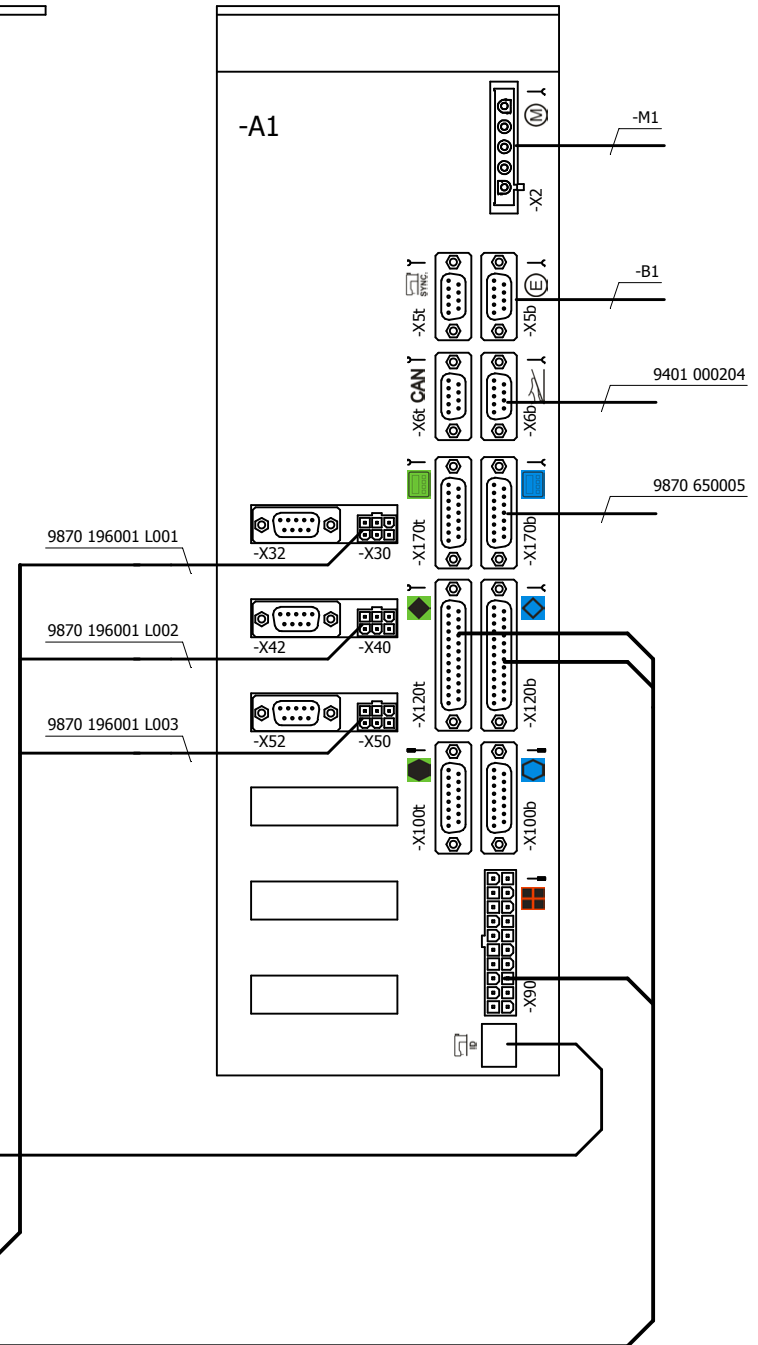
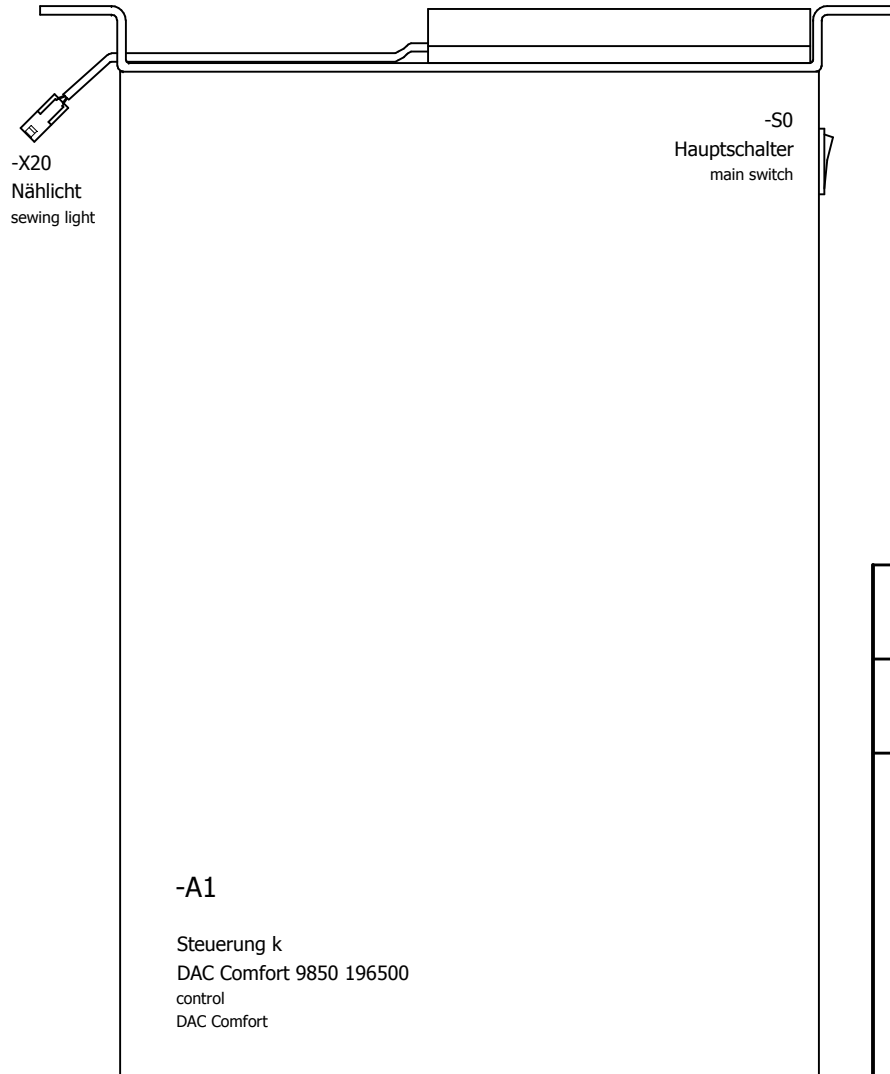
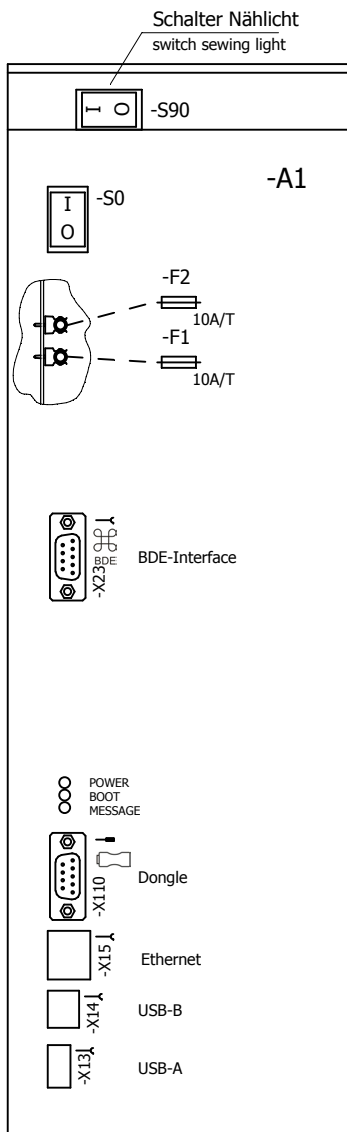

Masch-ID  
9850 001309

Leitungssatz  
9870 196001

Kabelbaum, harness  
9870 196000

c			Datum	26.01.2018
b			Bearb.	Görzen
a			Geprüft	
	Änd.	Datum	Name	Norm



Teilfamilie	8630
Freigabe	0016/17

KI. 196 (550-12-33/34)

Bauschaltplan

9890 196000 B

Blatt  
2 / 6

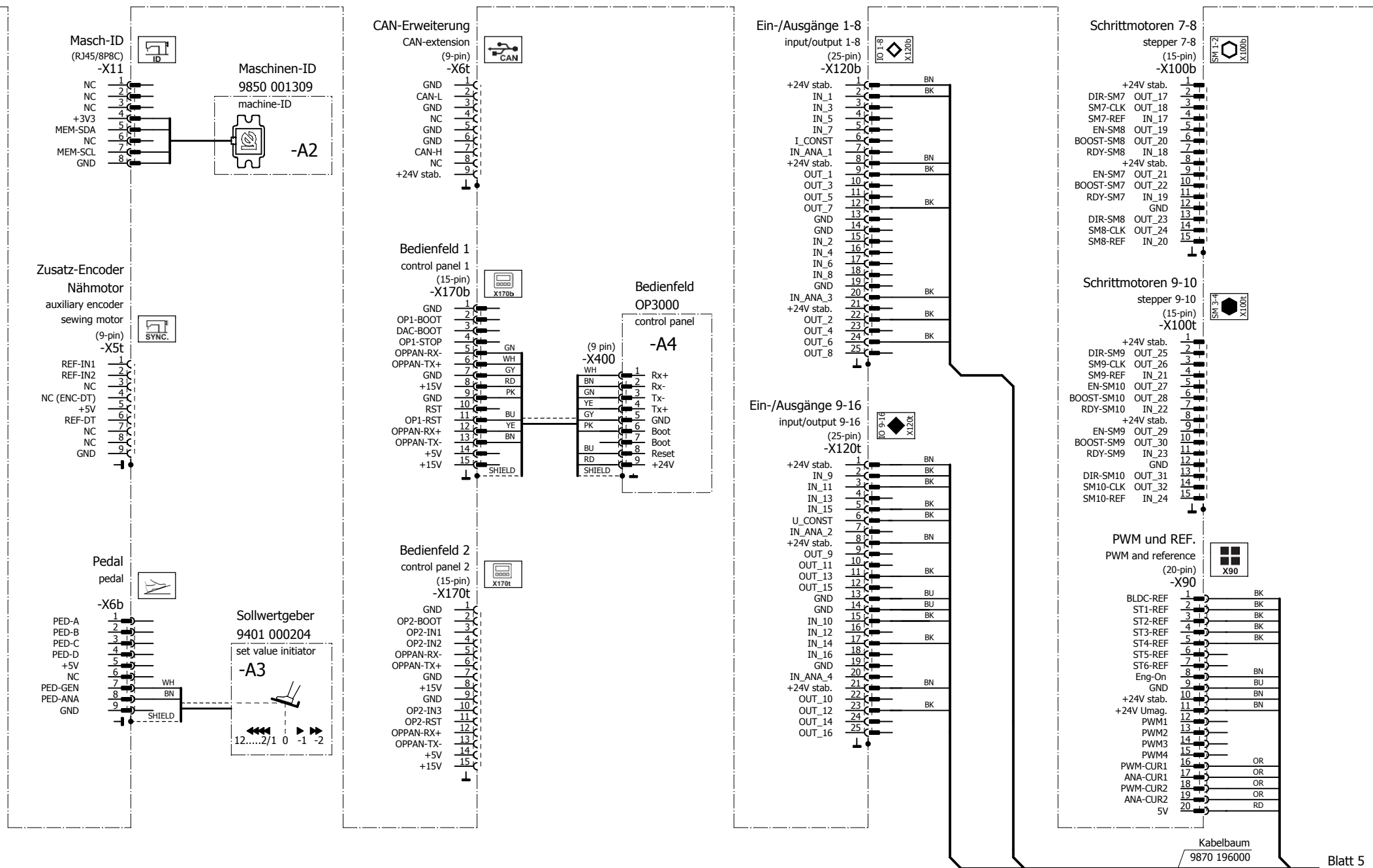

Kabelbaum  
9870 196000  
Blatt 5  
sheet 5

Zusatzausstattung  
Optional equipment

c		Datum	26.01.2018
b		Bearb.	Görzen
a		Geprüft	
Änd.	Datum	Name	Norm



Teilfamilie  
8630  
Freigabe  
0016/17

Kl. 196 (550-12-33/34)

Bauschaltplan  
9890 196000 B

Blatt  
3 / 6

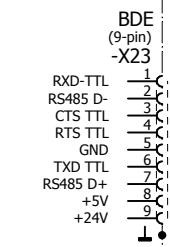
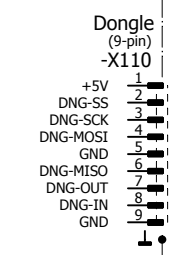
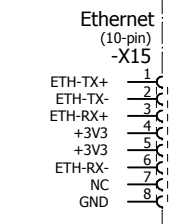
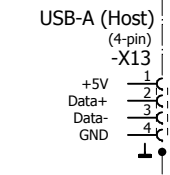
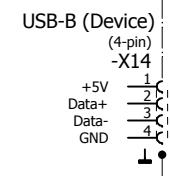
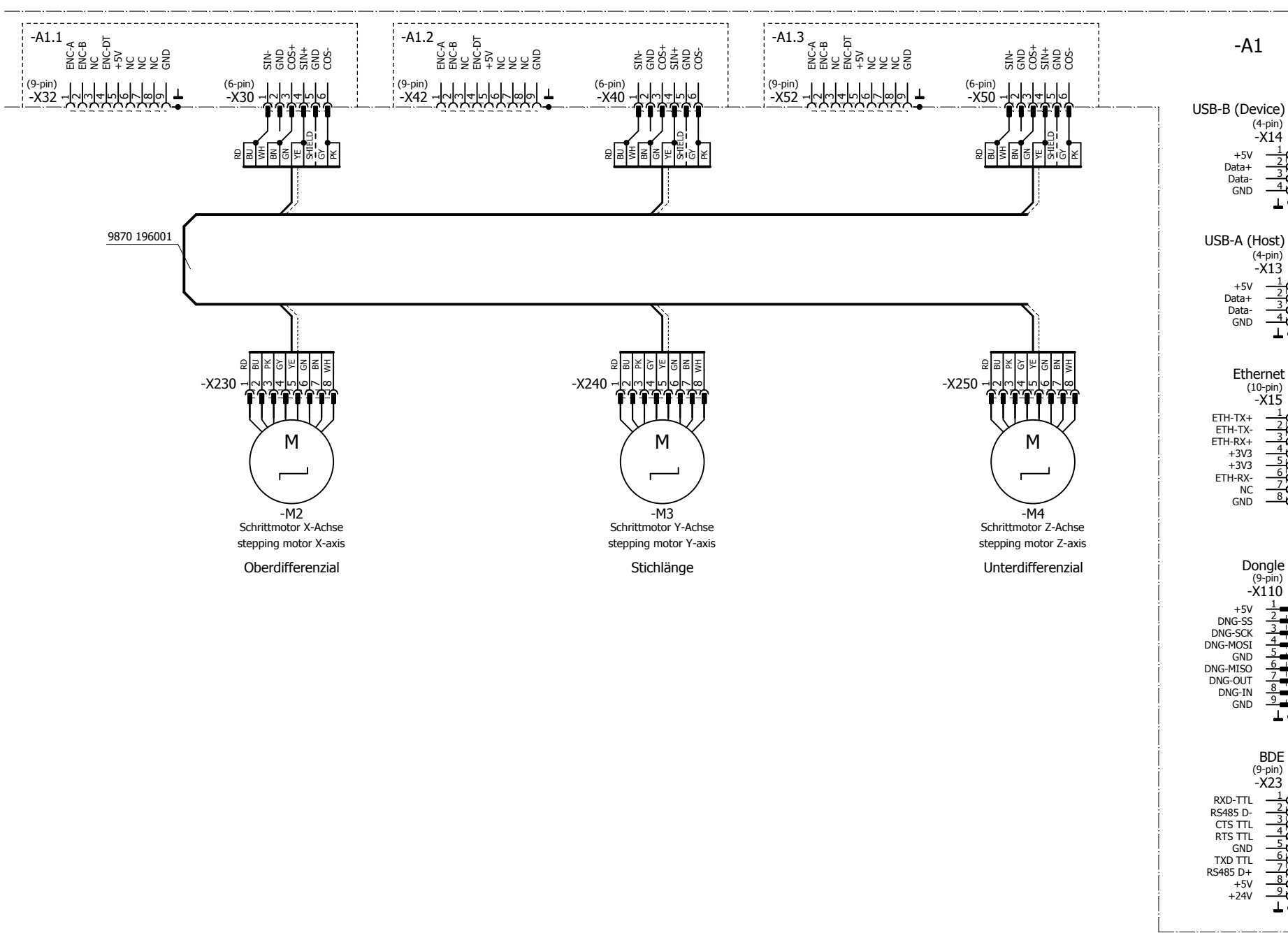

c		Datum	26.01.2018
b		Bearb.	Görzen
a		Geprüft	
	Änd.	Datum	Name
		Norm	



Teilfamilie	8630
Freigabe	0016/17

KI. 196 (550-12-33/34)

**Bauschaltplan**  
**9890 196000 B**

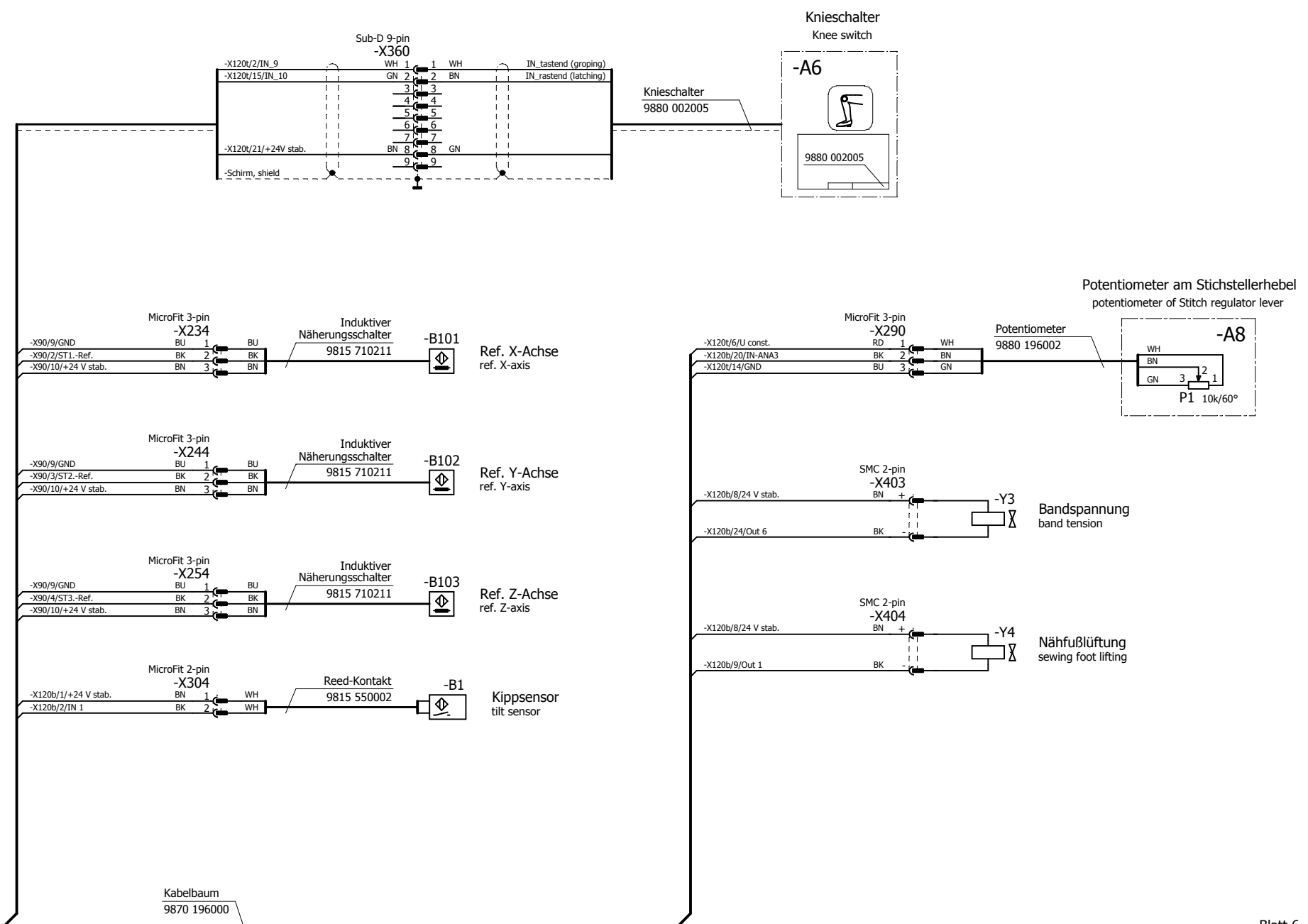

Zusatzausstattung  
Optional equipment

c			Datum	26.01.2018
b			Bearb.	Görzen
a			Geprüft	
Änd.	Datum	Name	Norm	



Teilfamilie	8630
Freigabe	0016/17

Kl. 196 (550-12-33/34)

**Bauschaltplan**  
**9890 196000 B**

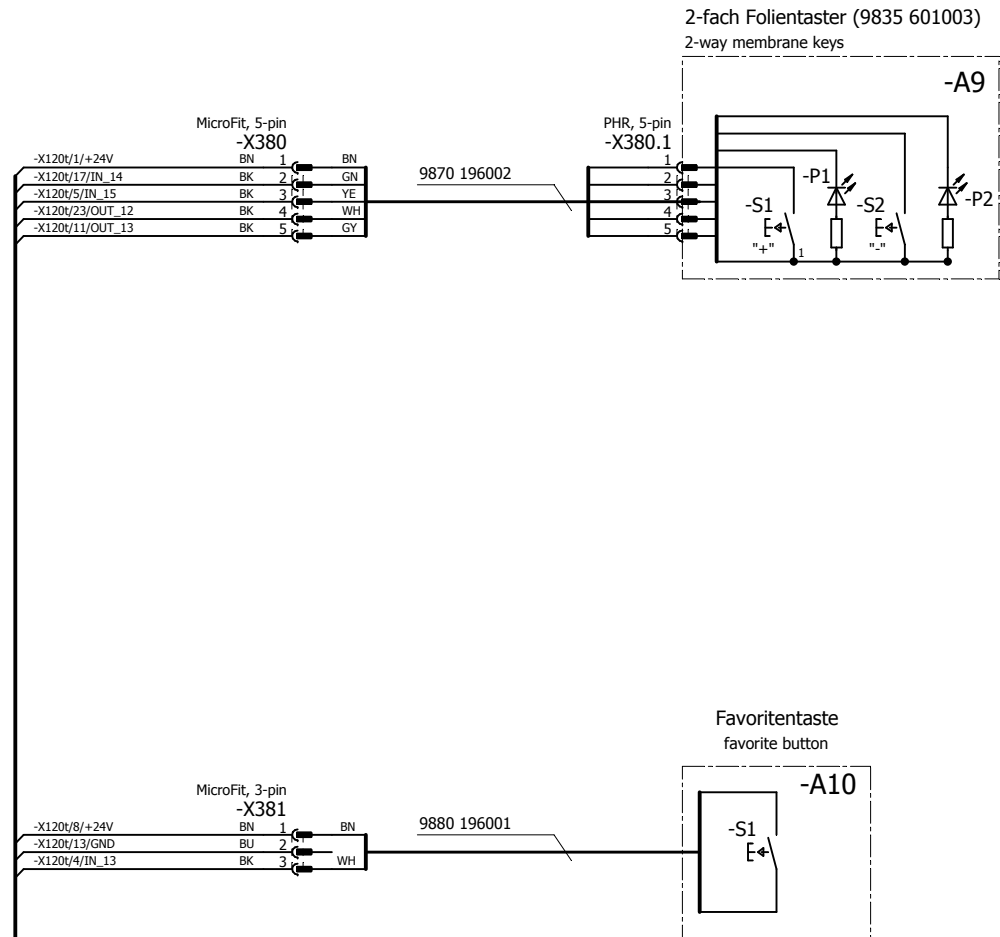
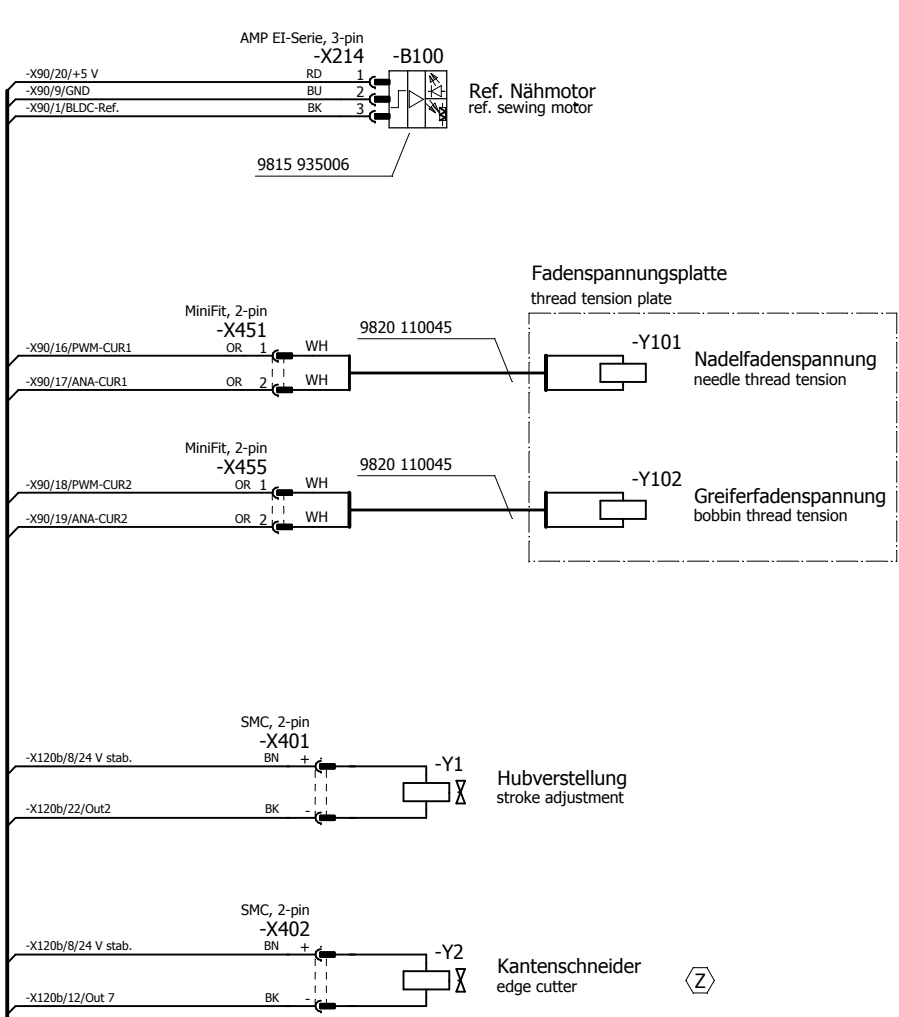

Blatt 5  
sheet 5

Zusatzausstattung  
Optional equipment

c			Datum	26.01.2018
b			Bearb.	Görzen
a			Geprüft	
	Änd.	Datum	Name	Norm



Teilfamilie	8630
Freigabe	0016/17

Kl. 196 (550-12-33/34)

**Bauschaltplan**  
**9890 196000 B**

0196-172620

0196-672620

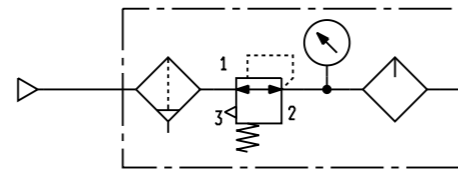
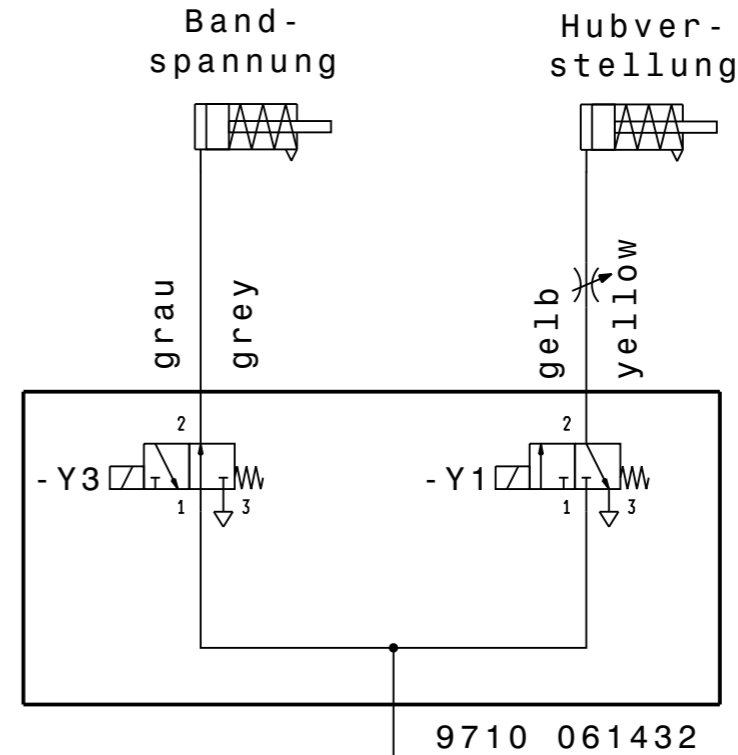
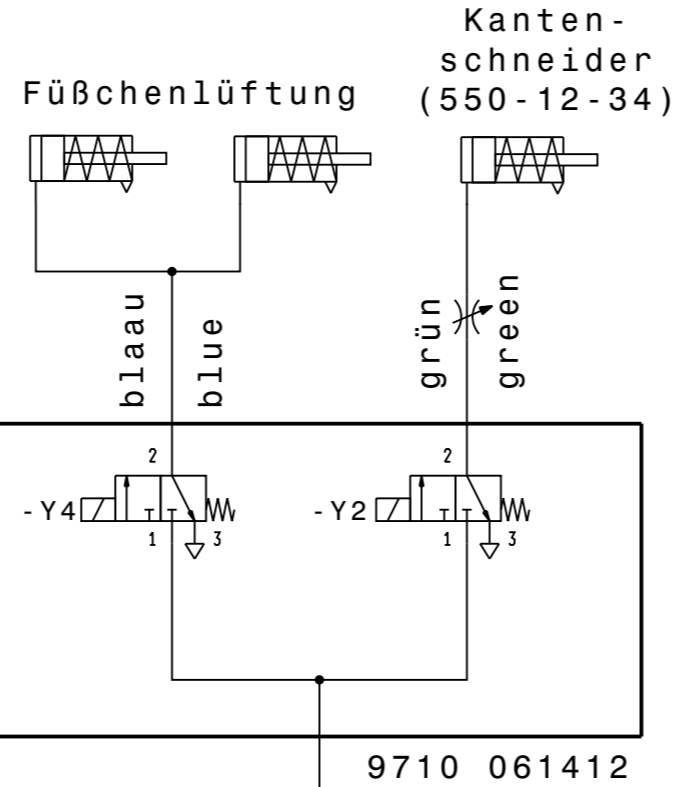
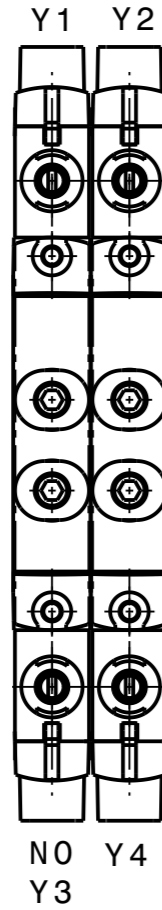
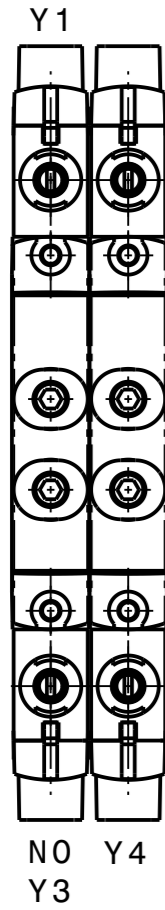

Schlauch hose	Teile Nr. (Meterware) Part-No. (yarded goods)
PU3 grau / grey	9731 005004
PU3 rot / red	9731 004014
PU3 grün / green	9731 004024
PU3 gelb / yellow	9731 004034
PU3 blau / blue	9731 004044

Änd.	Datum	gez.	gepr.	Datum	gez.	Lückenbach	gepr.	ges.
0.2	17.05.17	Lückenbach		02.02.16	gez.	Lückenbach	gepr.	ges.
0.1	02.12.16	Lückenbach		Pneu.-Geräteplan für 550-12-33 u. 550-12-34				



DÜRKOPP ADLER AG

**9770 196001**

Blatt 1 Blattz.

**Klasse/Class 550-12-33**

<b>Nr./No.</b>	<b>Teilenummer/ part number</b>	<b>Menge/ Quantity</b>	<b>Bezeichnung</b>	<b>Description</b>
1	0004 000079	1	Spannungsfeder	Tension spring
2	0055 000400	1	Spannungsfeder	Tension spring
3	0195 004591	1	Nadelschutzblech	Needle protection
4	0195 004753	1	Greifer	Looper
5	0196 102007	1	Transporteur	Feed dog
6	0196 102008	1	Transporteur	Feed dog
7	0211 050214	1	Spannungsscheibe	Tension washer
8	0271 000199	1	Stegscheibe	Disc
9	0291 000159	1	Fadenführung	Thread guide
10	0933 001460	1	Feder	Spring
11	0933 079777	1	Feder	Spring
12	0965 000543	1	Nadelschutz	Needle guard

**Klasse/Class 550-12-34**

<b>Nr./No.</b>	<b>Teilenummer/ part number</b>	<b>Menge/ Quantity</b>	<b>Bezeichnung</b>	<b>Description</b>
1	0004 000079	1	Spannungsfeder	Tension spring
2	0055 000400	1	Spannungsfeder	Tension spring
3	0195 004591	1	Nadelschutzblech	Needle protection
4	0195 004753	1	Greifer	Looper
5	0195 010127	1	Obermesser	Upper knife
6	0196 101028	1	Untermesser	Lower knife
7	0196 102007	1	Transporteur	Feed dog
8	0196 102008	1	Transporteur	Feed dog
9	0211 050214	1	Spannungsscheibe	Tension washer
10	0271 000199	1	Stegscheibe	Disc
11	0291 000159	1	Fadenführung	Thread guide
12	0933 001460	1	Feder	Spring
13	0933 079777	1	Feder	Spring
14	0965 000543	1	Nadelschutz	Needle guard



DÜRKOPP ADLER AG

Potsdamer Straße 190

33719 Bielefeld

GERMANY

Phone +49 (0) 521 / 925-00

E-mail [service@duerkopp-adler.com](mailto:service@duerkopp-adler.com)

[www.duerkopp-adler.com](http://www.duerkopp-adler.com)

