



G767

# Инструкции по обслуживанию

**IMPORTANT**  
**READ CAREFULLY BEFORE USE**  
**KEEP FOR FUTURE REFERENCE**

All rights reserved.

Property of Dürkopp Adler GmbH and protected by copyright. Any reuse of these contents, including extracts, is prohibited without the prior written approval of Dürkopp Adler GmbH.

Copyright © Dürkopp Adler GmbH 2024

<b>1</b>	<b>Об этих инструкциях .....</b>	<b>5</b>
1.1	Для кого предназначены эти инструкции?.....	5
1.2	Символы и знаки.....	5
1.3	Другие документы.....	7
1.4	Обязанность.....	7
<b>2</b>	<b>Безопасность.....</b>	<b>9</b>
2.1	Основные инструкции по технике безопасности.....	9
2.2	Слова и символы, используемые в предупреждениях.....	10
<b>3</b>	<b>Рабочая основа .....</b>	<b>13</b>
3.1	Порядок корректировок.....	13
3.2	Прокладка кабелей.....	13
3.3	Снятие крышек.....	14
3.3.1	Доступ к нижней части машины.....	14
3.3.2	Снятие и установка крышки рукава.....	15
3.3.3	Снятие и установка крышки головки .....	16
3.3.4	Снятие и установка задней крышки.....	17
3.3.5	Снятие и установка крышки головки.....	18
3.3.6	Снятие и установка держателя панели управления .....	19
3.3.7	Разборка и сборка натяжной пластины.....	20
3.3.8	Разборка и сборка крышки зубчатого ремня.....	22
3.3.9	Открытие и закрытие задвижной игольной пластины.....	23
3.3.10	Разборка и сборка игольной пластины .....	24
3.3.11	Разборка и сборка транспортера.....	25
3.4	Плоские цапфы на валах .....	26
3.5	Блокировка машины на месте.....	27
3.6	Установка маховика в положение.....	29
<b>4</b>	<b>Позиционирование вала рукава.....</b>	<b>31</b>
<b>5</b>	<b>Позиционирование зубчатых ремней .....</b>	<b>33</b>
5.1	Установка зубчатого ремня на вал двигателя.....	33
5.2	Позиционирование верхнего зубчатого ремня.....	34
5.3	Позиционирование нижнего зубчатого колеса ремня.....	35
5.4	Регулировка натяжения зубчатого ремня .....	36
<b>6</b>	<b>Защелкивание предохранительной муфты.....</b>	<b>37</b>
<b>7</b>	<b>Регулировка колеса длины стежка .....</b>	<b>39</b>
7.1	Регулировка верхнего колеса длины стежка.....	39
7.2	Опускание колеса регулировки длины стежка .....	41
7.3	Регулировка ограничения длины стежка .....	42
7.4	Регулировка базовой настройки эксцентрика для прямого и обратного стежка.....	44
<b>8</b>	<b>Транспортер.....</b>	<b>46</b>
8.1	Регулировка положения транспортера .....	46
8.1.1	Перемещение транспортера .....	47
8.1.2	Перемещение держателя транспортера.....	48
8.2	Регулировка движения транспортера .....	49
8.2.1	Регулировка эксцентрика подачи .....	50
8.2.2	Регулировка эксцентрика подачи.....	51

8.2.3	Регулировка эксцентрика хода подачи.....	51
8.3	Регулировка высоты транспортера в В.М.Т.....	53
<b>9</b>	<b>Выравнивание тяги игловодителя.....</b>	<b>54</b>
9.1	Выравнивание тяги игловодителя вбок.....	54
9.2	Выравнивание тяги игловодителя в направлении шитья.....	57
<b>10</b>	<b>Положение челнока и иглы.....</b>	<b>58</b>
10.1	Регулировка зазора со стороны челнока.....	58
10.2	Регулировка положения хода петли.....	60
10.3	Регулировка высоты игловодителя .....	62
10.4	Регулировка защиты иглы.....	63
<b>11</b>	<b>Регулировка подъема шпульного колпачка.....</b>	<b>65</b>
11.1	Регулировка зазора подъема шпульного колпачка.....	66
11.2	Регулировка времени открытия .....	67
<b>12</b>	<b>Лапки для шитья.....</b>	<b>68</b>
12.1	Регулировка эксцентрика для хода верхней подачи .....	68
12.2	Регулировка равномерного хода лапок .....	70
12.3	Adjusting the adjusting frame .....	71
12.4	Регулировка высоты подъема лапки .....	72
<b>13</b>	<b>Регулировка пружины натяжения нити.....</b>	<b>74</b>
<b>14</b>	<b>Моталка .....</b>	<b>75</b>
14.1	Регулировка моталки .....	75
14.1.1	Разборка моталки.....	75
14.1.2	Базовая настройка намотчика.....	76
14.1.3	Настройка хода намотчика и автоматической остановки .....	76
14.1.4	Сборка моталки .....	78
14.2	Регулировка намоточного колеса.....	79
14.3	Регулировка нитенаправителя челнока.....	80
<b>15</b>	<b>Обрезчик нитей.....</b>	<b>81</b>
15.1	Регулировка высоты ножа для протягивания нити.....	81
15.2	Adjusting the cutoff curve .....	82
15.3	Регулировка давления резания .....	84
15.4	Корректировка момента времени для резки.....	85
<b>16</b>	<b>Короткая обрезка нити.....</b>	<b>87</b>
16.1	Adjusting the locking latch .....	90
16.2	Adjusting the thread-pulling knife .....	91
16.3	Регулировка контрлезвия .....	92
16.4	Регулировка положения среза.....	94
<b>17</b>	<b>Регулировка потенциометра.....</b>	<b>95</b>
<b>18</b>	<b>Программирование .....</b>	<b>97</b>
18.1	OP4000 Панель управления.....	97
18.1.1	Навигация по панели управления.....	97
18.1.2	Символы и плитки.....	97
18.2	Режимы работы ПО.....	98
18.3	Функции плиток.....	99

18.3.1	Регулировка начальной закрепки .....	101
18.3.2	Регулировка конечной закрепки .....	102
18.3.3	Регулировка счетчика количества стежков на шпуле.....	103
18.3.4	Счетчик штук.....	104
18.3.5	Максимальная скорость шитья.....	105
18.3.6	Регулировка положения иглы после остановки .....	106
18.3.7	Точка позиционирования.....	106
18.3.8	Активация плавного пуска .....	107
18.3.9	Блокировка экрана.....	107
18.4	Автоматический режим.....	108
18.5	Настройки.....	111
18.5.1	Настройки параметров .....	112
18.5.2	Сервис.....	115
18.5.3	Передача данных.....	120
<b>19</b>	<b>Обслуживание .....</b>	<b>121</b>
19.1	Уборка .....	122
19.1.1	Места, требующие особой очистки.....	122
19.1.2	Очистка сетки вентилятора двигателя.....	124
19.2	Смазка.....	125
19.2.1	Проверка уровня масла.....	126
19.2.2	Проверка смазки челнока.....	126
19.3	Обслуживание пневматической системы.....	127
19.3.1	Регулировка рабочего давления.....	127
19.3.2	Слив конденсата.....	129
19.3.3	Очистка фильтрующего элемента.....	130
19.4	Каталог запчастей.....	131
<b>20</b>	<b>Вывод из эксплуатации.....</b>	<b>133</b>
<b>21</b>	<b>Утилизация.....</b>	<b>135</b>
<b>22</b>	<b>Поиск неисправностей .....</b>	<b>137</b>
22.1	Обслуживание клиентов.....	137
22.2	Ошибки в процессе шитья .....	137
<b>23</b>	<b>Технические данные.....</b>	<b>139</b>
23.1	Данные и характерные значения .....	139
23.2	Требования к безотказной работе.....	139
<b>24</b>	<b>Приложение.....</b>	<b>141</b>
24.1	Электросхемы.....	141
24.2	Пневмосхемы.....	150



## 1 Об этих инструкциях

Данная инструкция была подготовлена с особой тщательностью. Она содержит информацию и указания, призванные обеспечить долговременную и надежную эксплуатацию.

Если вы заметили какие-либо несоответствия или у вас есть пожелания по улучшению, мы будем рады получить ваш отзыв через службу поддержки клиентов. (📖р. 137).

Рассматривайте инструкцию как часть продукта и храните ее в легкодоступном месте.

### 1.1 Для кого предназначены эти инструкции?

Настоящие инструкции предназначены для:

- Специалисты:

Эта группа имеет соответствующую техническую подготовку для выполнения технического обслуживания или устранения неисправностей.

Что касается минимальной квалификации и других требований, предъявляемых к персоналу, см. также главу «Безопасность».(📖р. 9).

### 1.2 Условные обозначения – символы и знаки

Различная информация в этих инструкциях представлена или выделена следующими символами для облегчения и быстрого понимания:



#### Правильная настройка

Указывает правильную настройку.



#### Нарушения

Указывает на помехи, которые могут возникнуть из-за неправильной настройки.



#### Крышка

Указывает, какие крышки необходимо снять, чтобы получить доступ к устанавливаемым компонентам..



**Действия, которые необходимо выполнять при работе на машине (шитье и оснащение)**



**Действия, которые необходимо выполнить для обслуживания, ремонта и установки**



**Действия, которые необходимо выполнить через панель управления программного обеспечения**

**Отдельные шаги пронумерованы:**

1. Первый шаг

2. Второй шаг

... Действия всегда должны выполняться в указанном порядке. Списки обозначены маркированными пунктами.

- **Результат выполнения операции**

Измените на машине или на дисплее/панели управления.



**Важно**



При выполнении шага этому моменту следует уделить особое внимание.



**Информация**

Дополнительная информация, например, об альтернативных вариантах эксплуатации.



**Задание**

Работа, которую необходимо выполнить до или после настройки.

**Ссылки**



Ссылка на другой раздел данной инструкции.

**Безопасность** Важные предупреждения для пользователя выделены отдельно.

Поскольку безопасность имеет особое значение, символы опасности, уровни опасности и соответствующие сигнальные слова описаны отдельно в главе «Безопасность». (📖 р. 9).

**Информация о местоположении**

Если на рисунке не используется другая четкая информация о местоположении, обозначения правой и левой стороны всегда даются с точки зрения пользователя.

### 1.3 Другие документы

В машине используются компоненты других производителей. Каждый производитель провел оценку опасности приобретаемых деталей и подтвердил соответствие их конструкции действующим европейским и национальным нормам. Надлежащее использование встроенных компонентов описано в инструкциях соответствующего производителя.

### 1.4 Обязанность

Вся информация и примечания в данной инструкции составлены в соответствии с новейшими технологиями и применимыми стандартами и правилами.

Компания Dürkopp Adler не несет ответственности за любой ущерб, возникший в результате:

- Поломки и повреждения при транспортировке
- Несоблюдение данных инструкций
- Неправильное использование
- Несанкционированные модификации машины
- Использование неквалифицированного персонала
- Использование несертифицированных деталей

#### Транспортировка

Компания Dürkopp Adler не несет ответственности за поломки и повреждения при транспортировке. Осмотрите товар сразу после получения. О любых повреждениях сообщите менеджеру по доставке. Это правило действует также в случае, если упаковка не повреждена

Оставьте машины, оборудование и упаковочные материалы в том состоянии, в котором они находились на момент обнаружения повреждения. Это обеспечит возможность предъявления претензий к транспортной компании.

Обо всех прочих жалобах сообщайте в компанию Dürkopp Adler немедленно после получения товара.



## 2 Безопасность

В этой главе содержится основная информация по безопасности. Внимательно прочтите инструкции перед настройкой и эксплуатацией машины. Обязательно следуйте инструкциям по технике безопасности. Несоблюдение этих инструкций может привести к серьезным травмам и материальному ущербу.



### 2.1 Основные инструкции по технике безопасности

Машину разрешается использовать только в соответствии с настоящими инструкциями.

Настоящие инструкции должны быть всегда доступны в месте установки машины.

Работа с токоведущими компонентами и оборудованием запрещена.

Исключения определены в DIN VDE 0105.

Для выполнения следующих работ выключите машину главным выключателем или отсоедините вилку кабеля питания:

- Замена иглы или других швейных инструментов
- Покидание рабочего места
- Выполнение технического обслуживания и ремонта
- Заправка ниток

Отсутствие или неисправность деталей может снизить безопасность и повредить машину. Используйте оригинальные детали от производителя

#### Транспортировка

Для транспортировки используйте подъемную тележку или штабелер. Поднимите станок максимум на 20 мм и закрепите его, чтобы он не соскользнул.

#### Setup

Соединительный кабель должен иметь вилку, одобренную в соответствующей стране. Подсоединение вилки к кабелю питания должно осуществляться только квалифицированными специалистами.

#### Обязанности оператора

Соблюдайте действующие в вашей стране правила техники безопасности и предотвращения несчастных случаев, а также правовые нормы, касающиеся промышленной безопасности и охраны окружающей среды.

Все предупреждающие знаки и знаки безопасности на машине всегда должны быть разборчивыми. Не снимайте их!

Отсутствующие или поврежденные предупреждающие знаки и знаки безопасности должны быть немедленно заменены.

#### Требования, предъявляемые к персоналу

Только квалифицированные специалисты могут быть привлечены для:

- Настройка машины
- Выполнение работ по техническому обслуживанию и ремонту
- Выполнение работ с электрооборудованием

На машине могут работать только уполномоченные лица, которые должны предварительно изучить данные инструкции.

<b>Осмотр</b>	Проверяйте машину во время работы на наличие видимых повреждений. Прекратите работу, если заметите изменения в работе машины. Сообщите о любых изменениях своему руководителю. Не используйте поврежденную машину дальше.
<b>Средства безопасности</b>	Средства безопасности не следует разбирать или отключать. Если для проведения ремонта необходимо разобрать или отключить средства безопасности, их следует немедленно собрать и ввести в эксплуатацию.



## 2.2 Сигнальные слова и символы



Предупреждения в тексте обозначены цветными полосами. Цветовая схема зависит от степени опасности. Сигнальные слова указывают на степень опасности.

**Сигнальные слова** Сигнальные слова и опасность, которую они описывают:

Сигнальные слова	Описание
<b>DANGER</b>	(с символом опасности). Игнорирование может привести к смерти или серьёзным травмам.
<b>WARNING</b>	(с символом опасности) Игнорирование может привести к смерти или серьёзным травмам.
<b>CAUTION</b>	(с символом опасности) В случае игнорирования может возникнуть травма средней или лёгкой тяжести.
<b>CAUTION</b>	(с символом опасности) Игнорирование может привести к нанесению вреда окружающей среде.
<b>NOTICE</b>	(без символа опасности) Игнорирование может привести к повреждению имущества.

**Символы** Следующие символы указывают на тип опасности для персонала:

Изначек	Тип опасности
	Общий
	Поражение электрическим током

Изначек	Тип опасности
	Прокол
	Дробление
	Ущерб окружающей среде

**Примеры** Примеры оформления предупреждений в тексте:

### DANGER



Вид и источник опасности!  
Последствия несоблюдения требований.  
Меры по предотвращению опасности.

↪ Так выглядит предупреждение об опасности, игнорирование которой может привести к серьезным травмам или даже смерти.

### WARNING



Вид и источник опасности!  
Последствия несоблюдения требований.  
Меры по предотвращению опасности.

↪ Так выглядит предупреждение об опасности, игнорирование которой может привести к серьезным или даже смертельным травмам.

### CAUTION



Вид и источник опасности!  
Последствия несоблюдения требований.  
Меры по предотвращению опасности.

↪ Так выглядит предупреждение об опасности, которая может привести к травме средней или легкой степени тяжести, если его игнорировать.

**CAUTION**

Вид и источник опасности!  
Последствия несоблюдения требований.  
Меры по предотвращению опасности.

- ↪ Так выглядит предупреждение об опасности, игнорирование которой может привести к нанесению ущерба окружающей среде.

**NOTICE**

Вид и источник опасности!  
Последствия несоблюдения требований.  
Меры по предотвращению опасности.

- ↪ Так выглядит предупреждение об опасности, игнорирование которой может привести к материальному ущербу.

## 3 Рабочая основа

### 3.1 Порядок корректировок

#### NOTICE

Существует риск повреждения оборудования из-за неправильного порядка действий.  
Крайне важно соблюдать порядок действий, указанный в данной инструкции.

#### Порядок



Положения настроек швейной машины взаимосвязаны. Всегда соблюдайте указанный порядок выполнения отдельных этапов настройки.

Крайне важно следовать всем уведомлениям относительно предварительных условий и последующих настроек, отмеченным на полях.

### 3.2 Прокладка кабелей

#### NOTICE

Может быть причинен ущерб имуществу!  
Неправильная прокладка кабелей может привести к повреждению машины и сбоям в её работе.  
Избыточная длина кабеля может нарушить работу движущихся частей машины. Это ухудшает качество шитья и может привести к повреждению.  
Уложите излишнюю длину кабеля, как описано в данной инструкции.



Для прокладки кабелей:

1. Аккуратно уложите излишки кабеля в соответствующие кабельные зажимы.
2. Свяжите кабельные петли кабельными стяжками.



#### Важно

По возможности прикрепите петли к неподвижным частям. Кабели должны быть надежно закреплены.

3. Обрежьте все перекрывающие друг друга кабельные стяжки.

### 3.3 Демонтаж крышек

#### CAUTION



Опасность травмирования движущимися частями!  
Возможно защемление.  
Перед снятием и установкой крышек выключите машину.

Для многих видов регулировочных работ вам придется сначала снять крышки машины, чтобы получить доступ к компонентам.

В этой главе описывается, как снять и установить отдельные крышки. В тексте для каждого типа регулировочных работ указывается только та крышка, которую необходимо снять в данный момент.

#### 3.3.1 Доступ к нижней части машины

Чтобы получить доступ к компонентам в нижней части машины, необходимо сначала наклонить головку машины.

*Fig. 1: Доступ к нижней части машины*

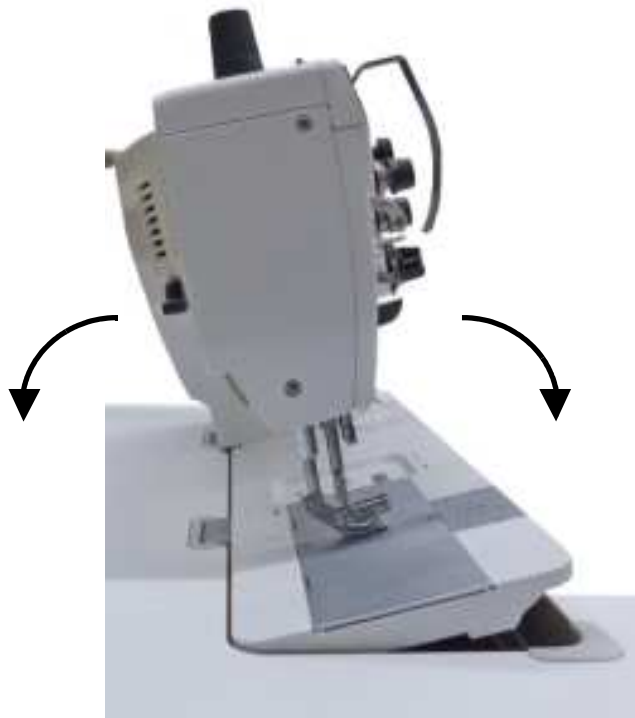

#### Наклон головки машины



Чтобы наклонить головку машины:

1. Наклоните головку машины как можно дальше.

### Erecting the machine head



To erect the machine head:

1. Erect the machine head.

### 3.3.2 Снятие и установка верхней крышки рукава

Fig. 2: Снятие и установка верхней крышки рукава

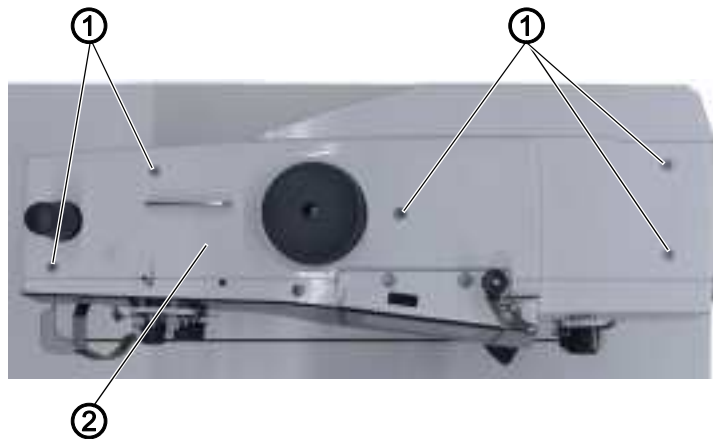

(1) - Винты

(2) - Крышка рукава

#### Снятие крышки рукава



Чтобы снять крышку рукава:

2. Ослабьте винты (1).
3. Снимите крышку рукава (2).

#### Установка крышки рукава



Чтобы установить крышку рукава:

4. Установите крышку рукава(2).
5. Затяните винты (1).

### 3.3.3 Снятие и установка боковой крышки головки

Fig. 3: Снятие и установка боковой крышки головки

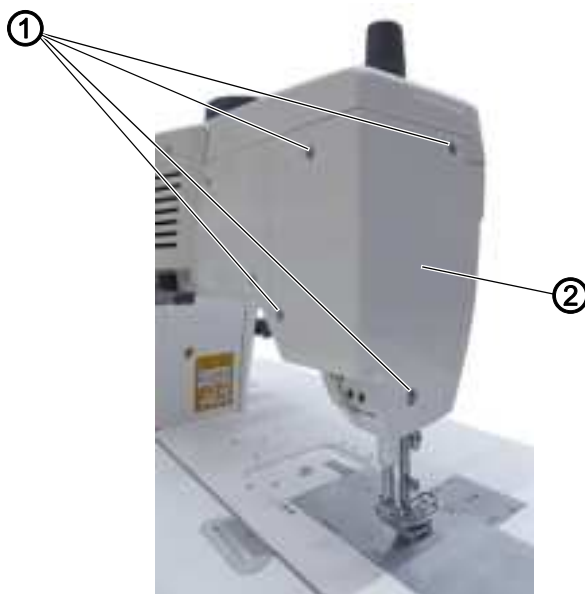

(1) - Винты

(2) - Крышка головки

#### Снятие крышки головки



Чтобы снять крышку головки:

1. Ослабьте винты (1).
2. Снимите крышку головки (2).

#### Установка крышки головки



Чтобы установить крышки головки :

1. Установите крышку головки (2).
2. Затяните винты (1).

### 3.3.4 Снятие и установка задней крышки

Fig. 4: Снятие и установка задней крышки

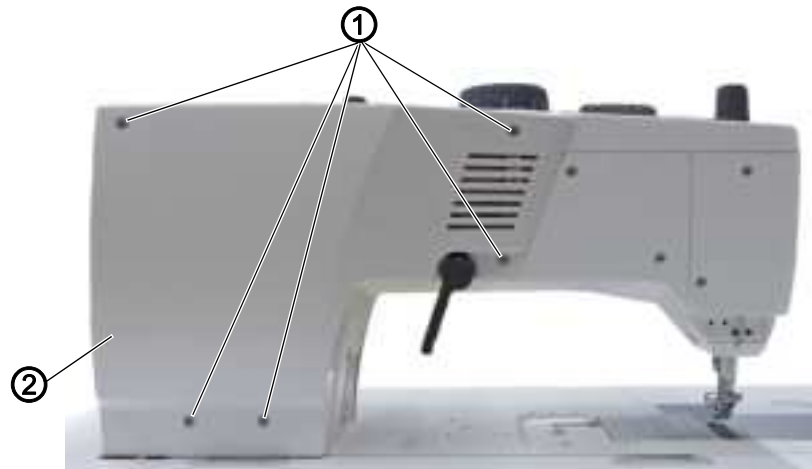

(1) - Винты

(2) - Задняя крышка

#### Снятие задней крышки.



Чтобы снять заднюю крышку:

1. Открутите винты (1).
2. Снимите заднюю крышку (2).

#### Установка задней крышки.



Чтобы установить заднюю крышку:

1. Установите заднюю крышку (2).
2. Затяните винты (1).



#### Важно

При установке крышки следите за тем, чтобы не защемить кабели.

### 3.3.5 Снятие и установка верхних крышек

Fig. 5: Снятие и установка верхних крышек

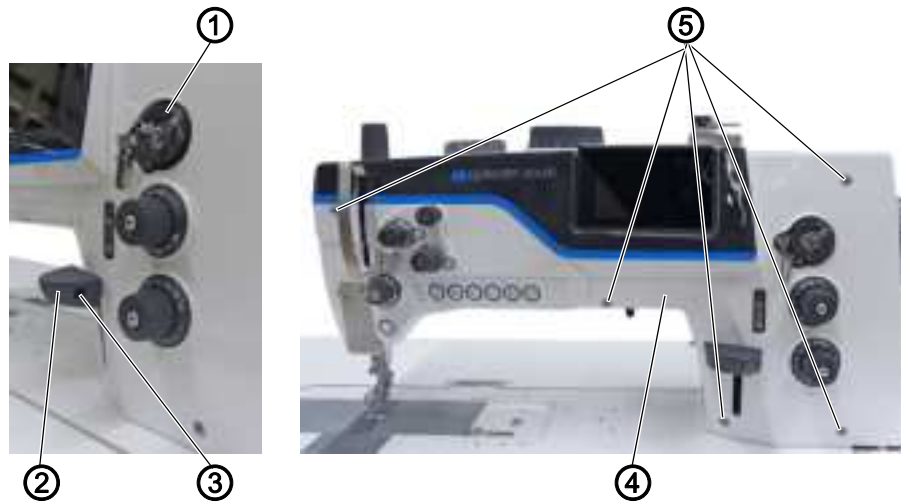

- |                                  |                       |
|----------------------------------|-----------------------|
| (1) - Намотчик шпули             | (4) - Передняя крышка |
| (2) - Рукоятка регулятора стежка | (5) - Винты           |
| (3) - Винт                       |                       |

#### Снятие верхней крышки.



Чтобы снять переднюю крышку:

1. Loosen the screw (3).
2. Pull off the stitch regulator handle (2).
3. Switch on the winder (1).
4. Loosen the screws (5).
5. Remove the front cover (4).

#### Placing the front cover



To place the front cover:

1. Switch on the winder (1).
2. Place the front cover (4).
3. Tighten the screws (5).
4. Fit the stitch regulator handle (2).
5. Tighten the screw (3).

### 3.3.6 Removing and placing the control panel holder

Fig. 6: Removing and placing the control panel holder

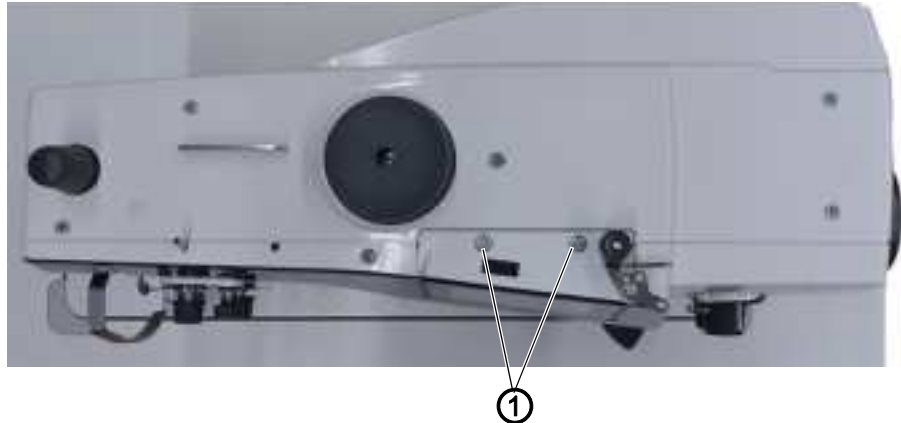

(1) - Screws



#### Removing the control panel holder

1. To remove the control panel:
  1. Remove the front cover ( p. 18).
  2. Loosen the screws (1).

#### Placing the control panel holder



To place the control panel:

1. Tighten the screws (1).
2. Place the front cover ( p. 18).



#### Important

When placing the cover, make sure not to pinch any cables.

### 3.3.7 Disassembling and assembling the tensioning plate

Fig. 7: Disassembling and assembling the tensioning plate (1)

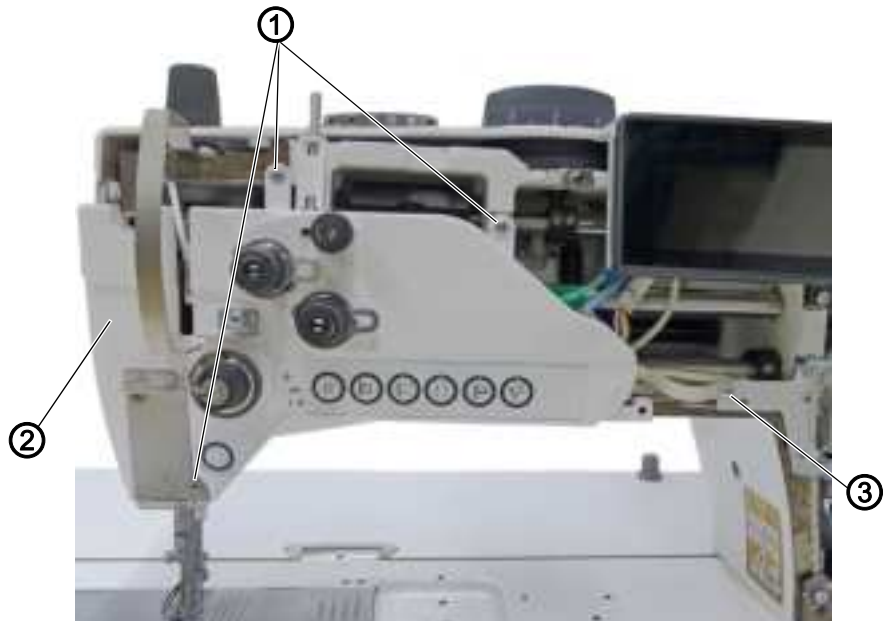

(1) - Screws

(3) - Equipotential bonding

(2) - Tensioning plate

#### Disassembling the tensioning plate



To disassemble the tensioning plate:

1. Remove the front cover (📖 p. 18).
2. Remove the control panel (📖 p. 19).
3. Loosen the equipotential bonding (3).
4. Loosen the screws (1).
5. Remove the tensioning plate (2).

Fig. 8: Disassembling and assembling the tensioning plate (2)

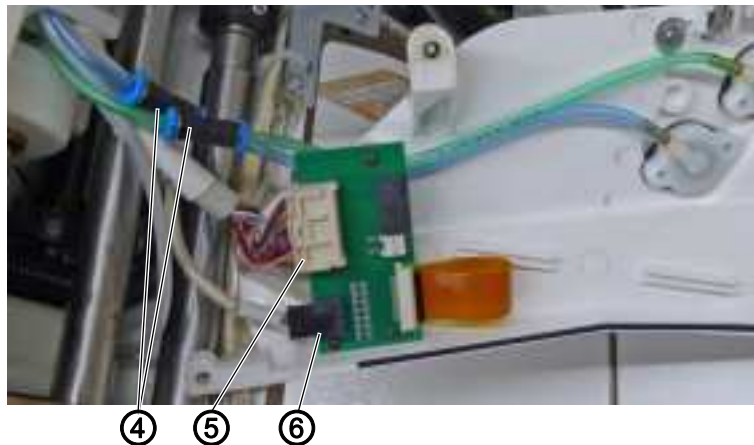

(4) - Compressed air lines  
(5) - Plug



(6) - Plug

6. Pull off plugs (5) and (6).
7. Disconnect the compressed air line (4).

### Assembling the tensioning plate



To assemble the tensioning plate:

1. Connect the compressed air lines (6).
2. Insert plugs (4) and (5).
3. Place the tensioning plate (2).
4. Tighten the screws (1).
5. Assemble the equipotential bonding (3).
6. Place the control panel ( p. 19).
7. Place the front cover ( p. 18).

### 3.3.8 Disassembling and assembling the toothed belt cover

Fig. 9: Disassembling and assembling the toothed belt cover



(1) - Handwheel  
(2) - Screws

(3) - Belt cover  
(4) - Screws

#### Disassembling the toothed belt cover



To disassemble the toothed belt cover:

1. Loosen screws (2) on the handwheel (1).
2. Remove the handwheel (1).
3. Loosen the screws (4).
4. Remove the toothed belt cover (3); start by disassembling the cover from below.

#### Assembling the toothed belt cover



To assemble the toothed belt cover:

1. Place the toothed belt cover (3).
2. Tighten screws (2) and (4).



#### Important

Make sure not to pinch any cables.

### 3.3.9 Opening and closing the throat plate slide

Fig. 10: Opening and closing the throat plate slide

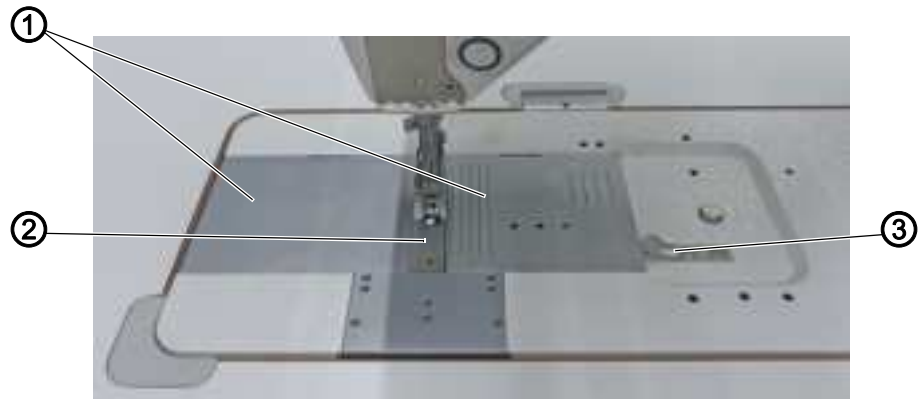

(1) - Throat plate slide  
(2) - Throat plate

(3) - Clamping spring

#### Opening the throat plate slide



To open the throat plate slide:

1. Press the clamping spring (3) downwards.
2. Push the throat plate slide (1) apart.

#### Closing the throat plate slide



To close the throat plate slide:

1. Push the throat plate slide (1) up to the throat plate (2).

### 3.3.10 Disassembling and assembling the throat plate

#### CAUTION



**Risk of injury from sharp and moving parts!**

Puncture or crushing possible.

Switch off the machine before you disassemble or assemble the throat plate.

Fig. 11: Disassembling and assembling the throat plate



(1) - Screws

(2) - Throat plate

(3) - Bobbin case

(4) - Nose

#### Disassembling the throat plate



To disassemble the throat plate:

1. Open the throat plate slide ( p. 23).
2. Loosen the screws (1).
3. Remove the throat plate (2).

#### Assembling the throat plate



To assemble the throat plate:

1. Insert the throat plate (2).  
Ensure that the nose (4) of the bobbin case (3) is in the cutout of the throat plate.
2. Tighten both screws (1).
3. Close the throat plate slide ( p. 23).

### 3.3.11 Disassembling and assembling the feed dog

#### CAUTION



**Risk of injury from sharp and moving parts!**

Puncture or crushing possible.

Switch off the machine before you disassemble or assemble the feed dog.

Fig. 12: Disassembling and assembling the feed dog

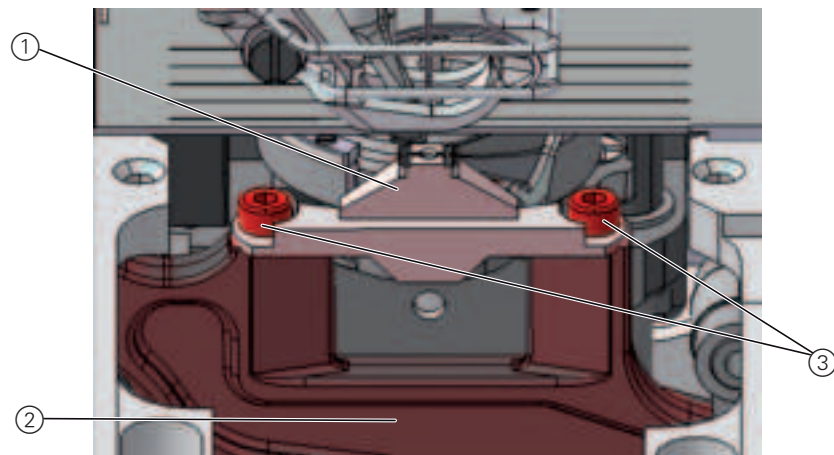

(1) - Feed dog

(2) - Feed dog carrier

(3) - Screws

#### Disassembling the feed dog



To disassemble the feed dog:

1. Disassemble the throat plate ( p. 24).
2. Loosen the screws (3).
3. Remove the feed dog (1) from the feed dog carrier (2).

#### Assembling the feed dog



To assemble the feed dog:

1. Place the feed dog (1) onto the feed dog carrier (2).
2. Align the feed dog (1) such that the needle pierces in the center of the needle hole.
3. Tighten the screws (3).
4. Insert the throat plate ( p. 24).



#### Important

Check the feed dog position in its movement at maximum stitch length (depending on the equipment: 6, 9 or 12) by turning the handwheel. The feed dog must not hit against the throat plate.



**Order**

Then check the following adjustment:

- Feed dog ( p. 47)

**3.4 Flats on shafts**

Fig. 13: Flats on shafts

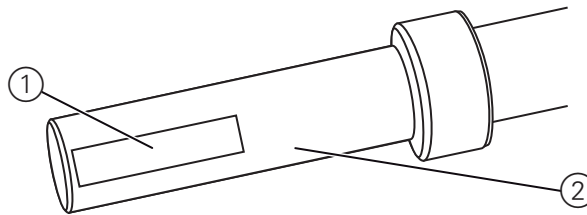

(1) - Flat

(2) - Shaft

Some shafts have flat surfaces at the points where the components are screwed on. This stabilizes the connection and makes adjusting easier.



**Important**

Ensure that the screws are completely flush with the surface.

### 3.5 Locking the machine in place

For some adjustments, the machine must be locked in the looping stroke position. To do this, the locking peg from the accessories is inserted into a slot on the arm shaft crank, blocking the arm shaft.

Fig. 14: Locking the machine in place (1)

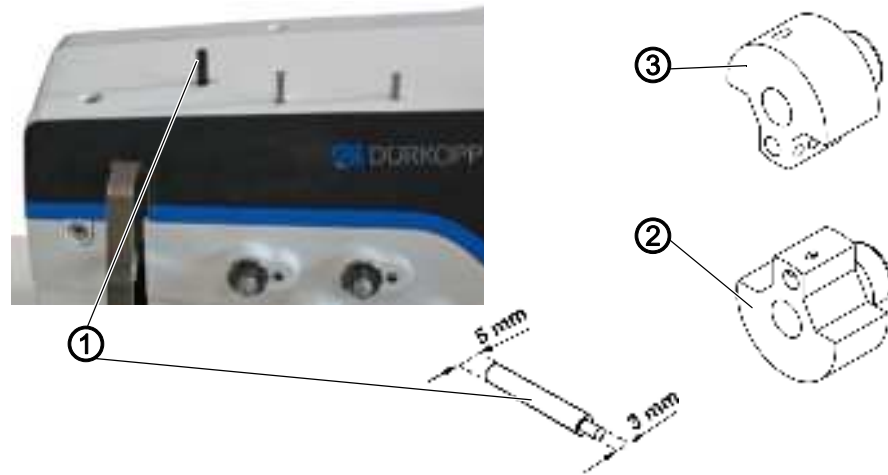

(1) - Locking peg

(2) - Handwheel zero position

(3) - Looping stroke position

#### There are 2 securing positions:

- **Securing position 1:** Looping stroke position (3)
  - 5 mm end in the large slot
  - Adjusting the looping stroke and needle bar height
- **Securing position 2:** Handwheel zero position (2)
  - 3 mm end in the small slot
  - Adjusting the handwheel position and checking the top dead center for the needle bar

Fig. 15: Locking the machine in place

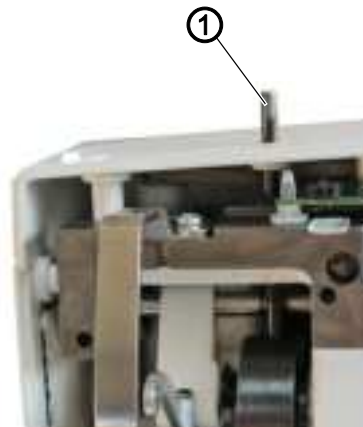

(1) - Locking peg

**Locking the machine in place**

To lock the machine in place

1. Turn the handwheel until the appropriate slot is in front of the locking opening:
  - Small groove at handwheel position 0°
  - Large slot at handwheel position 200 – 205°
2. Insert the locking peg (1) with the appropriate end into the slot.

**Removing the lock**

To remove the lock:

1. Pull the locking peg (1) out of the slot in the machine arm.

### 3.6 Adjusting the handwheel into position

For some settings, the graduated scale on the handwheel has to be moved to a certain position.

Fig. 16: Adjusting the handwheel into position

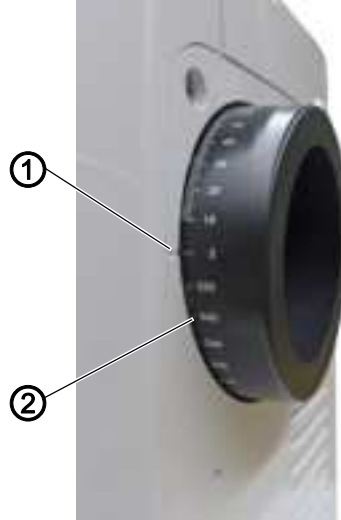

(1) - Marking

(2) - Graduated scale



To adjust the handwheel into position:

1. Turn the handwheel until the required number on the graduated scale (2) is next to the marking (1).



## 4 Positioning the arm shaft

### CAUTION



#### Risk of injury from moving parts!

Crushing possible.

Switch off the machine before you check and set the position of the arm shaft crank.



#### Proper setting

The ball bearing (1) is seated flush with the locking ring (2).  
The threaded pins (3) are seated completely flush on the flat of the arm shaft (5).  
The flat of the crank (4) extends further outward than the flat of the arm shaft (5). The flat of the arm shaft (5) is offset slightly towards the rear.



#### Cover





- Removing the arm cover ( p. 15)
- Removing the head cover ( p. 16)
- Removing the front cover ( p. 18)
- Disassembling the tensioning plate ( p. 20)

Fig. 17: Positioning the arm shaft crank



- (1) - Ball bearing  
(2) - Locking ring  
(3) - Threaded pins

- (4) - Flat of crank  
(5) - Flat of arm shaft



To position the arm shaft:

1. Loosen the threaded pins (3).
2. Turn the arm shaft so that the threaded pins (3) are seated completely flush on the flat.
3. Position the arm shaft so that the face of the arm shaft (5) is flush with the face of the crank (4).
4. Tighten the threaded pins (3).

## 5 Positioning the toothed belt wheels

### CAUTION



#### Risk of injury from moving parts!

Crushing possible.

Switch off the machine before you check and set the toothed belt wheels.

The two toothed belt wheels must be positioned above each other so that the toothed belt can run correctly.

### 5.1 Positioning the toothed belt wheel on the motor shaft



#### Cover



- Removing the arm cover ( p. 15)
- Removing the belt cover ( p. 22)

Fig. 18: Positioning the toothed belt wheel on the motor shaft



- (1) - Threaded pins  
(2) - Slot

- (3) - Feather key  
(4) - Toothed belt wheel

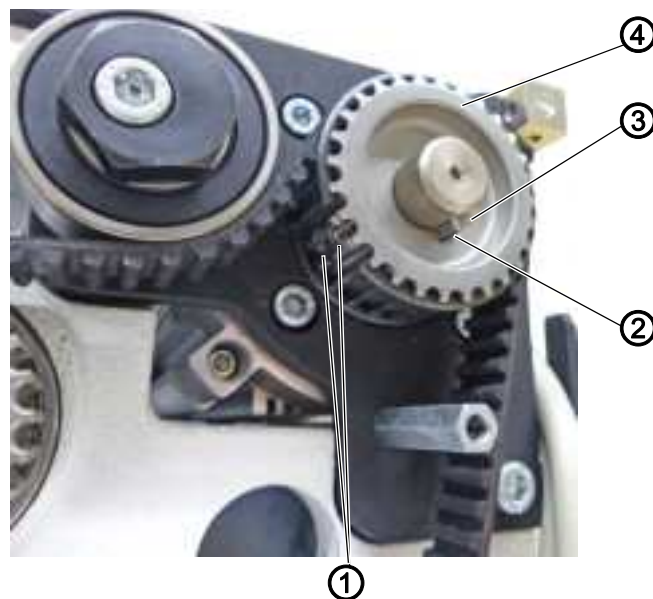

To position the toothed belt wheel on the motor shaft:

1. Fit the feather key (3) into the slot (2) of the toothed belt wheel (4).
2. Push the toothed belt wheel (4) with the feather key (3) up against the motor shaft.
3. Tighten the threaded pins (1).

## 5.2 Positioning the upper toothed belt wheel



### Proper setting

The threaded pins (1) and (2) for the upper toothed belt wheel (3) are seated completely flush on the flat. The ball bearing abuts on the locking ring.



### Cover

- Removing the arm cover (📖 p. 15)
- Removing the front cover (📖 p. 18)
- Removing the handwheel
- Removing the belt cover (📖 p. 22)

Fig. 19: Positioning the upper toothed belt wheel

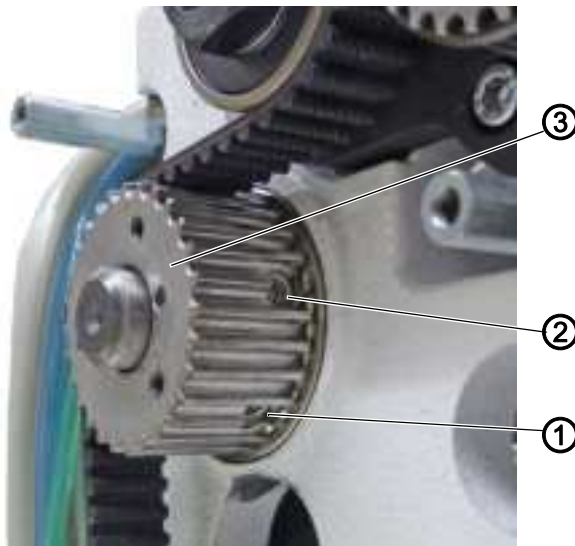

(1) - Threaded pin  
(2) - Threaded pin

(3) - Toothed belt wheel



To position the upper toothed belt wheel:

1. Loosen threaded pins (1) and (2).
2. Turn the toothed belt wheel (3) such that the 1<sup>st</sup> threaded pin (2) in the direction of rotation is seated completely flush on the flat of the arm shaft.
3. Tighten threaded pins (1) and (2).

### 5.3 Positioning the lower toothed belt wheel



#### Proper setting

The threaded pins (2) and (3) for the lower toothed belt wheel (1) are seated completely flush on the flat of the lower shaft.

The ball bearing (5) abuts on the locking ring (4).



#### Cover



- Removing the belt cover ( p. 22)
- Removing the lower belt cover
- Tilting the machine head ( p. 14)

Fig. 20: Positioning the lower toothed belt wheel



(1) - Toothed belt wheel  
(2) - Threaded pin  
(3) - Threaded pin

(4) - Locking ring  
(5) - Ball bearing

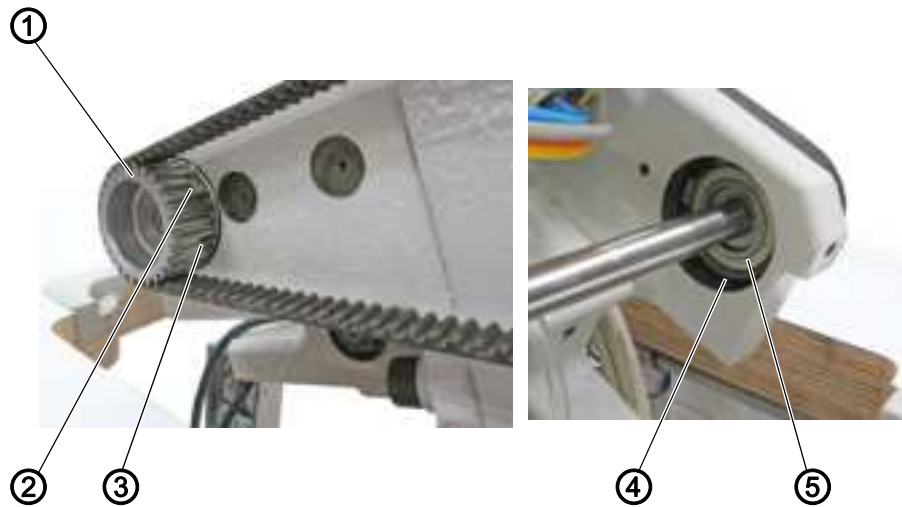

To position the lower toothed belt wheel:

1. Unscrew the lower belt cover.
2. Loosen threaded pins (2) and (3).
3. Turn the toothed belt wheel (1) such that the 1<sup>st</sup> threaded pin (2) in the direction of rotation is seated flush on the flat of the arm shaft.
4. Tighten the threaded pins (2) and (3) such that the first screw in the direction of rotation is seated on the flat.

## 5.4 Adjusting the toothed belt tension



### Cover

- Removing the handwheel
- Removing the belt cover (📖 p. 22)

Fig. 21: Adjusting the toothed belt tension

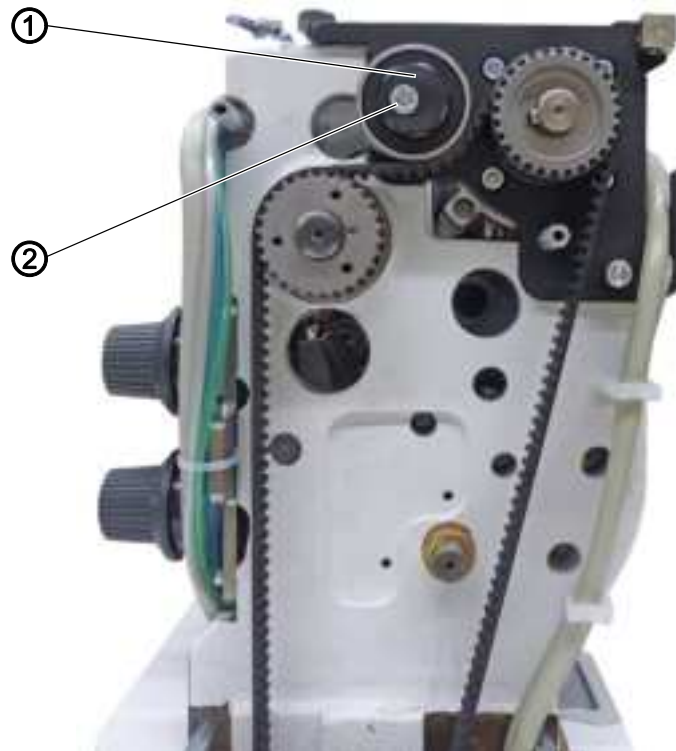

(1) - Eccentric

(2) - Screw



To adjust the toothed belt tension:

1. Loosen the screw (2).
2. Turn the eccentric (1).
3. Check and, if necessary, readjust the toothed belt tension.



### Information

The toothed belt tension is set to the optimum value when the belt oscillates at 75 Hz. Check the oscillation, for instance, using a device made by Contitech.

4. Tighten the screw (2).

## 6 Latching the safety release clutch

### CAUTION



#### Risk of injury from moving parts!

Crushing possible.

Switch off the machine before you latch, check or set the safety release clutch.

The safety release clutch disengages in the event of the thread jamming and thus prevents the hook from being misadjusted or damaged.



#### Proper setting

The threaded pins (1) next to the safety release clutch (2) must be parallel to one another.

After the clutch has disengaged, they are no longer parallel.



#### Cover

- Tilting the machine head ( p. 14)

Fig. 22: Latching the safety release clutch (1)



(1) - Threaded pins

(2) - Safety release clutch

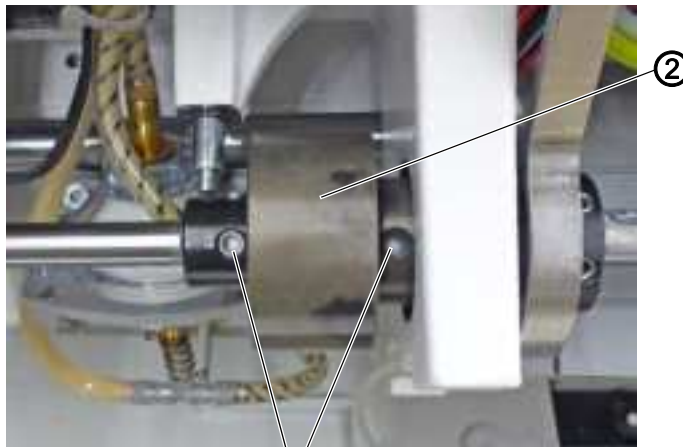
Fig. 23: Latching the safety release clutch (2)

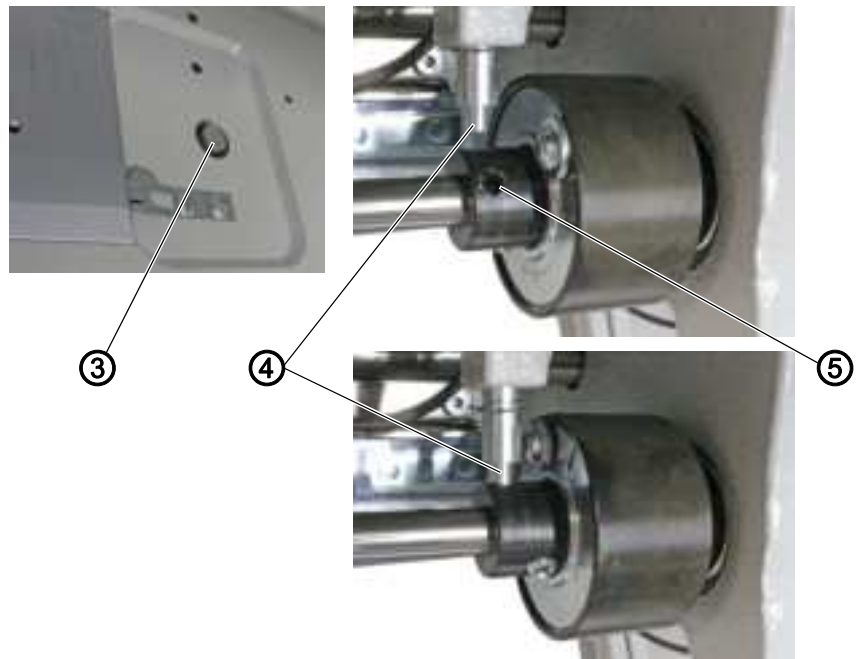

(3) - Button  
(4) - Pin

(5) - Hole



To latch the safety release clutch:

1. Press and hold the button (3) on the upper side of the throat plate. The pin (4) must be seated in the hole (5).
  2. Turn the handwheel until the threaded pins (1) are in parallel position.
- ↳ The safety release clutch latches into place.

## 7 Adjusting the stitch length adjusting wheel

### CAUTION



#### Risk of injury from moving parts!

Crushing possible.

Switch off the machine before you adjust the stitch length adjusting wheel.

### NOTICE

#### Property damage may occur!

Risk of machine damage if the shaft is turned too hard.

If you turn the shaft too far, parts on the stitch regulator gear may bend or get stuck.

Turn the shaft carefully and stop as soon as you feel a slight resistance.

### 7.1 Adjusting the upper stitch length adjusting wheel



#### Proper setting

1. Set the stitch length adjusting wheel to 0:



No play on the stitch regulator gear.

The plates (4) for the gear are parallel; the adjusting frame (6) cannot be moved.



#### Cover

• Removing the front cover ( p. 18)

*Fig. 24: Adjusting the upper stitch length adjusting wheel (1)*

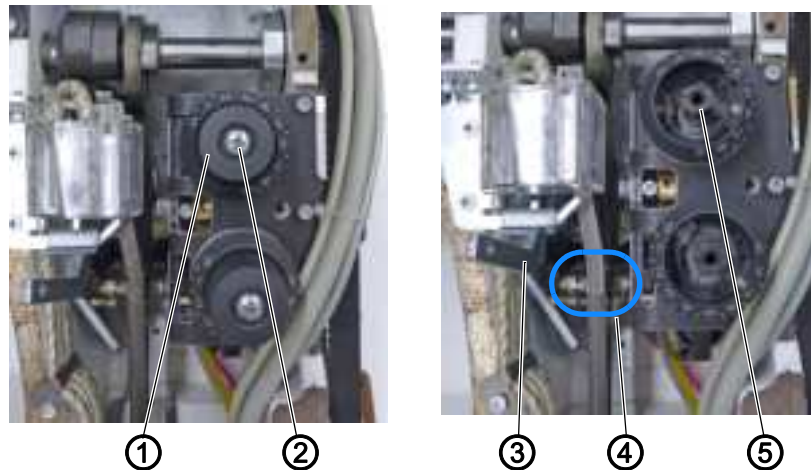

- |                                     |               |
|-------------------------------------|---------------|
| (1) - Stitch length adjusting wheel | (4) - Plates  |
| (2) - Screw                         | (5) - Spindle |
| (3) - Lever                         |               |



To adjust the stitch length adjusting wheel:

1. Switch off the machine.
2. Hold the stitch length adjusting wheel (1) in place.
3. Loosen the screw (2).
4. Remove the stitch length adjusting wheel (1) from the spindle (5).
5. Carefully turn the spindle (5) clockwise using a 10 mm wrench.

*Fig. 25: Adjusting the upper stitch length adjusting wheel (2)*



- |             |                       |
|-------------|-----------------------|
| (3) - Lever | (6) - Adjusting frame |
|-------------|-----------------------|

6. Check whether the adjusting frame (6) can be moved with the lever (3).
7. As soon as the adjusting frame (6) stops moving: Remove the wrench from the spindle (5).
8. Turn the scale ring clockwise as far as it will go.
- ↳ The stitch length is **0**.
9. Place the stitch length adjusting wheel (1) on the spindle (5).
10. Tighten the stitch length adjusting wheel (1) using the screw (2).

## 7.2 Lowering stitch length adjusting wheel



### Order

Adjust the upper stitch length adjusting wheel first before adjusting the lower stitch length adjusting wheel.



### Information

The lower stitch length adjusting wheel cannot be set higher than the upper stitch length adjusting wheel.

Fig. 26: Adjusting the lower stitch length adjusting wheel

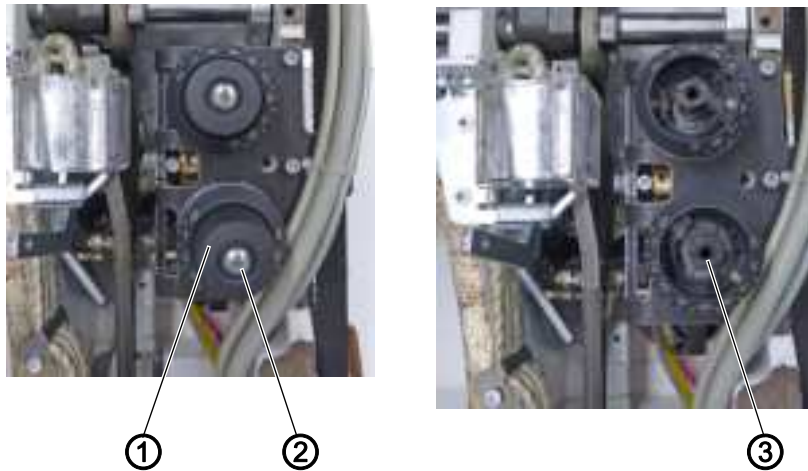

(1) - Stitch length adjusting wheel  
(2) - Screw

(3) - Spindle



To adjust the lower stitch length adjusting wheel:

1. Switch off the machine.
2. Hold the stitch length adjusting wheel (1) in place.
3. Loosen the screw (2).
4. Remove the stitch length adjusting wheel (1) from the spindle (3).
5. Carefully turn the spindle (3) as far as it will go using a 10 mm wrench.
6. Turn the scale ring counterclockwise as far as it will go.
7. Place the stitch length adjusting wheel (1) on the spindle (3).
8. Tighten the stitch length adjusting wheel (1) using the screw (2).

### 7.3 Adjusting the stitch length limit

#### NOTICE

##### Property damage may occur!

Risk of damaging the feed dog due to incorrect throat plate size. If the throat plate cutout is too small, the feed dog may hit against the edges.

Ensure that an appropriate throat plate is used for the selected maximum stitch length.

Not all stitch lengths may be available depending on the sewing equipment used.



#### Proper setting

1. Turn the stitch length counterclockwise as far as it will go.
- ↘ The stitch length adjusting wheel can only be turned up to the set maximum stitch length.

*Fig. 27: Adjusting the stitch length limit*

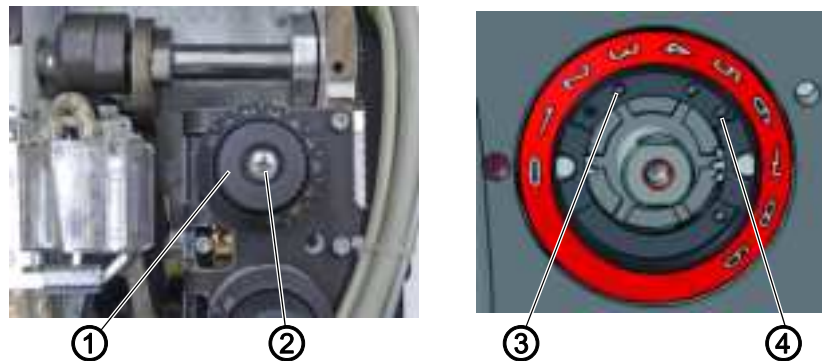

- |                                     |                                |
|-------------------------------------|--------------------------------|
| (1) - Stitch length adjusting wheel | (3) - Hole for stitch length 6 |
| (2) - Screw                         | (4) - Hole for stitch length 9 |



To adjust the stitch length limit:

1. Set the stitch length adjusting wheel (1) to **0**.
2. Hold the stitch length adjusting wheel (1) in place.
3. Loosen the screw (2).
4. Remove the stitch length adjusting wheel (1).
5. Loosen the threaded pin from one of the holes (3) or (4).
6. Screw the threaded pin into the hole for the required maximum stitch length. The holes are marked with numbers for the stitch length.
7. Turn the scale so that the **0** is exactly next to the adjusting mark.
8. Place the stitch length adjusting wheel (1) and hold it in place.

9. Tighten the screw (2).



**Information**

On machines with 2 stitch length settings, the stitch length limit can only be adjusted at the upper stitch length adjusting wheel.  
The limit of the lower stitch length adjusting wheel is automatically set accordingly.

---

## 7.4 Adjusting the basic eccentric setting for forward stitch and backward stitch



### Cover

- Tilting the machine head (📖 p. 14)

Fig. 28: Adjusting the basic eccentric setting for forward stitch and backward stitch (1)

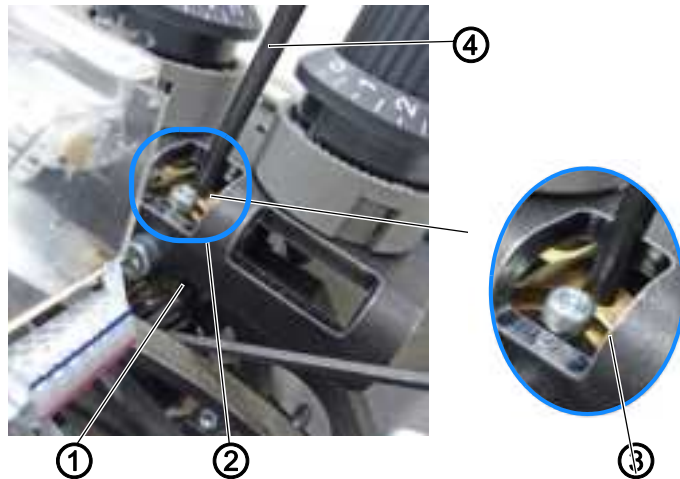

- (1) - Screw  
(2) - Slot

- (3) - Hole  
(4) - Locking peg



To adjust the basic eccentric setting for forward stitch and backward stitch:

1. Set the stitch length adjusting wheel to 0.
2. Loosen the screw (1).
3. Insert the locking peg (4) into the hole (3) and center it in the slot (2).
4. Tighten the screw (1).

Fig. 29: Adjusting the basic eccentric setting for forward stitch and backward stitch (2)

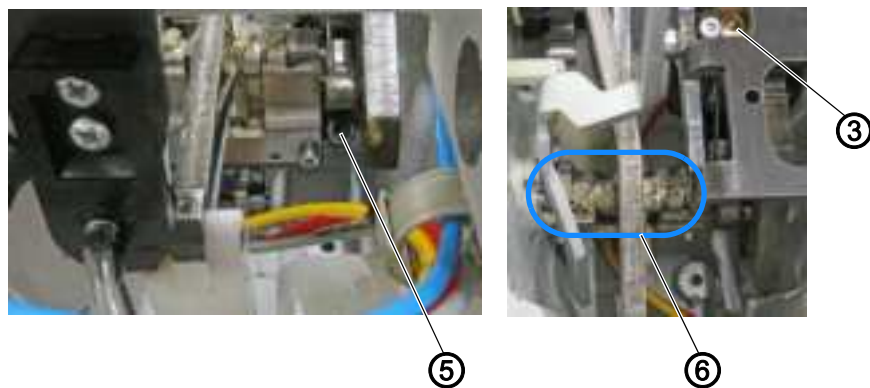

- (5) - Screw

- (6) - Plates



5. Tilt the machine down (📖 p. 14).
6. Loosen the screw (5).

7. Position the plates (6) so that they are parallel.
8. Tighten the screw (5).

## 8 Feed dog

The position and the movement of the feed dog and needle bar have to be coordinated such that the needle pierces exactly in the center of the needle hole of the feed dog.



### Order

First, check the following setting:

- Needle bar linkage ( p. 54)

### 8.1 Adjusting the feed dog position

#### CAUTION



#### Risk of injury from moving parts!

Crushing possible.

Switch off the machine before you set the feed dog position.





### Proper setting

When the stitch length is set to **0**, the feed dog is exactly in the center of the throat plate cutout, both sideways and in the sewing direction.

The needle must enter the needle hole precisely in the center.

Various settings can be made depending on how far the position of the feed dog differs from the correct setting:

- For minimal deviations, it suffices to move the feed dog on the carrier ( p. 47)
- If this is not sufficient, move the entire feed dog carrier on the pusher shaft ( p. 48)

### 8.1.1 Moving the feed dog



#### Cover

- Throat plate ( p. 24)

Fig. 30: Moving the feed dog

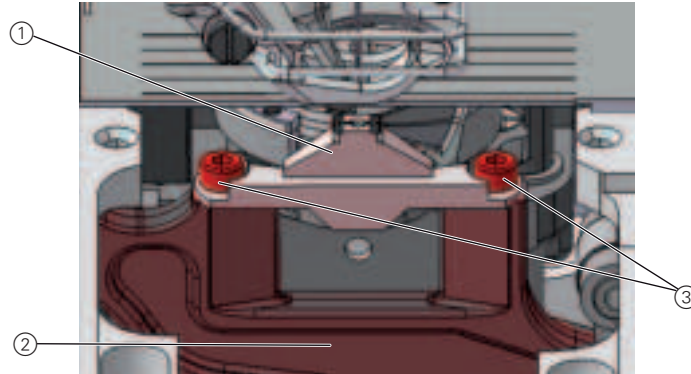

(1) - Feed dog

(2) - Feed dog carrier

(3) - Screws



To move the feed dog:

1. Loosen the screws (3).
2. Move the feed dog (1) on the feed dog carrier (2).  
Place the removed throat plate next to it as an aid for orientation so that the feed dog can be screwed on straight.
3. Tighten the screws (3).

### 8.1.2 Moving the feed dog carrier

The feed dog carrier is connected to the stitch regulator gear via the pusher shaft, and can be moved on this shaft.



#### Cover

- Tilting the machine head (📖 p. 14)

Fig. 31: Moving the feed dog carrier(1)

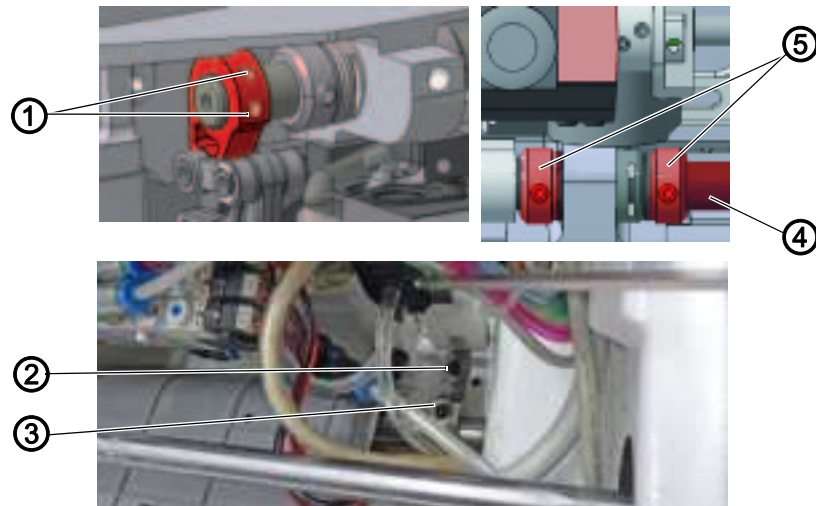

- (1) - Screws  
(2) - Screw  
(3) - Screw

- (4) - Pusher shaft  
(5) - Set collars



To move the feed dog carrier:

1. Set the stitch length adjusting wheel to **0**.
2. Loosen the screws (1).
3. Loosen the screw (3).
4. Loosen the threaded pins for the set collars (5).
5. Move the feed dog carrier perpendicular to the sewing direction so that the feed dog is exactly in the center of the throat plate cutout.
6. Push the set collars (5) toward each other as far as they will go.



#### Important

Make sure that the pusher shaft (4) is tightened by the set collars.

7. Tighten the threaded pins for the set collars (5).

Fig. 32: Moving the feed dog carrier (2)

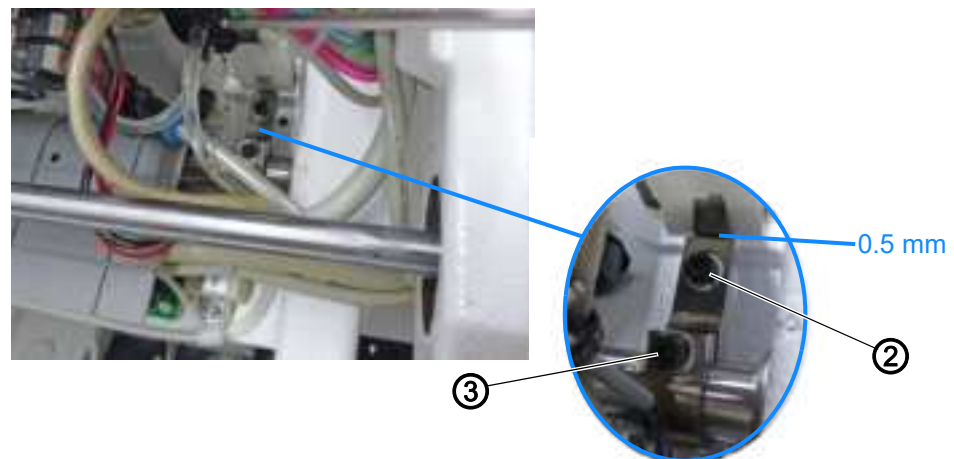

(2) - Screw

(3) - Screw

8. Loosen the screw (2).
9. Align the lever such that the distance between lever and block is 0.5 mm.
10. Tighten the screw (2).
11. Move the feed dog carrier in the sewing direction such that the feed dog is exactly in the center of the throat plate cutout.
12. Tighten the screw (3).
13. Tighten the screws (1).

**Important**

Make sure that the feed dog height has the proper setting ( p. 51).

**8.2 Adjusting the feed dog movement****CAUTION****Risk of injury from moving parts!**

Crushing possible.

Switch off the machine before you adjust the feed dog movement.

The feed dog moves in an elliptical cycle. To align this correctly, the feed movement, the stroke height, and the stroke movement of the feed dog all have to be adjusted.



**Order**

First, check the following setting:

- Feed dog position (📖 p. 46)

**8.2.1 Adjusting the feed eccentric**



**Cover**

- Removing the front cover (📖 p. 18)

Fig. 33: Adjusting the feed eccentric

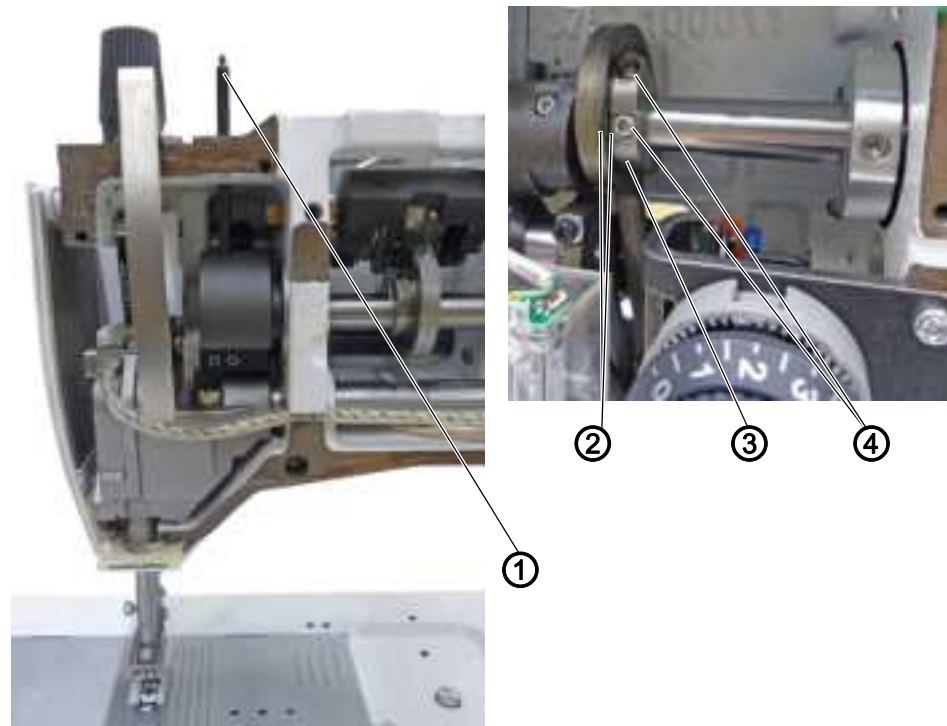

- (1) - Locking peg
- (2) - Markings

- (3) - Eccentric
- (4) - Threaded pins



To adjust the feed movement:

1. Lock the machine in place in the looping stroke position using the locking peg (1)(5 mm).
- ↳ The needle is in the looping stroke position.
2. Loosen threaded pins (4) on the eccentric (3).
3. Turn the eccentric (3) until the markings (2) line up.
4. Tighten the threaded pins (4).

## 8.2.2 Adjusting the compensating weight



### Order

Adjust the following setting first:

- Adjust the feed eccentric ( p. 50)



### Proper setting

The screw of the compensating weight (2) must be parallel with the 1<sup>st</sup> screw in the direction of rotation (5) of the eccentric (4).



### Cover

- Removing the front cover ( p. 18)

Fig. 34: Adjusting the compensating weight

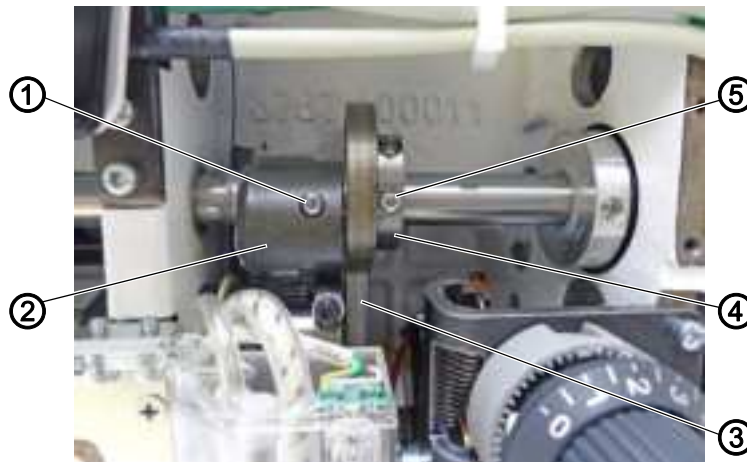

- (1) - Screw  
(2) - Compensating weight  
(3) - Pull rod

- (4) - Eccentric  
(5) - 1<sup>st</sup> screw in the direction of rotation



To adjust the compensating weight:

1. Loosen the screw (1).
2. Turn the compensating weight (2) so that the screw of the compensating weight (1) is parallel with the 1<sup>st</sup> screw in the direction of rotation (5) of the eccentric (4).  
The distance between the compensating weight (2) and the pull rod (3) is approx. 1 mm.
3. Tighten the screw (1).

## 8.2.3 Adjusting the feed stroke eccentric

### Cover

- Tilting the machine head ( p. 14)

Fig. 35: Adjusting the feed stroke eccentric

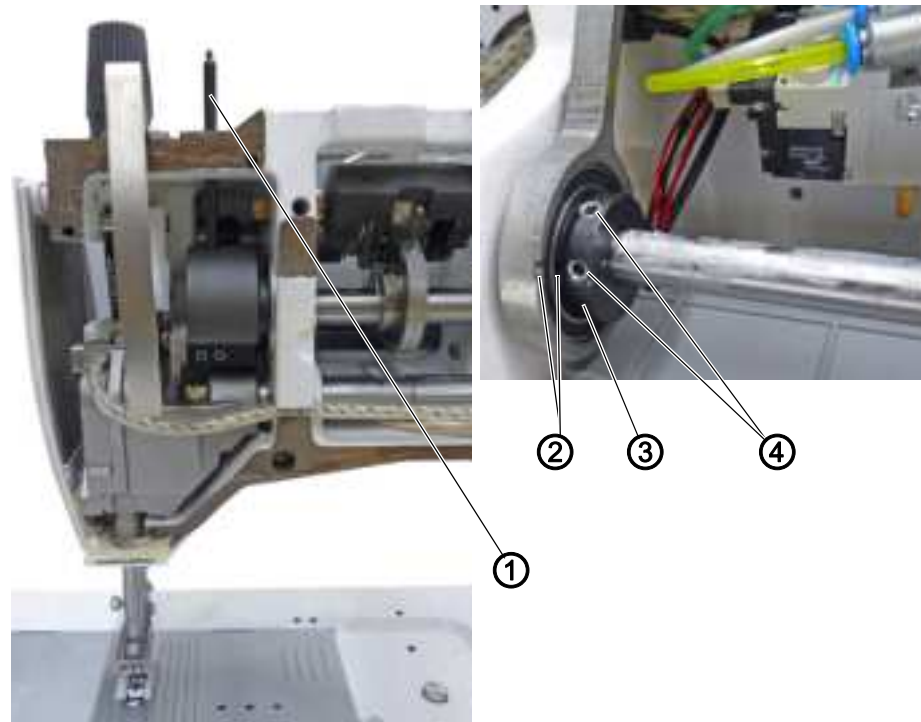

(1) - Locking peg  
(2) - Markings

(3) - Eccentric  
(4) - Threaded pins



To adjust the feed stroke eccentric:

1. Lock the machine in place in the looping stroke position using the locking peg (1)(5 mm).
- ↳ The needle is in the looping stroke position.
2. Loosen threaded pins (4) on the eccentric (3).
3. Turn the eccentric (3) until the markings (2) line up.
4. Tighten the threaded pins (4).

### 8.3 Adjusting the feed dog height at top dead center

The feed dog reaches the maximum stroke height at top dead center when the handwheel is positioned at 185°.



#### Proper setting

1. Place the feed dog in the uppermost position by turning the handwheel.
- ↪ The upper edge of the feed dog protrudes 0.5 mm above the throat plate.
- ↪ In machines with short thread trimmers (KFA), the upper edge of the feed dog protrudes 0.8 mm above the throat plate.



#### Cover



- Disassembling the tensioning plate ( p. 20)
- Tilting the machine head ( p. 14)

Fig. 36: Adjusting the feed dog height at top dead center



(1) - Lever

(2) - Threaded pins

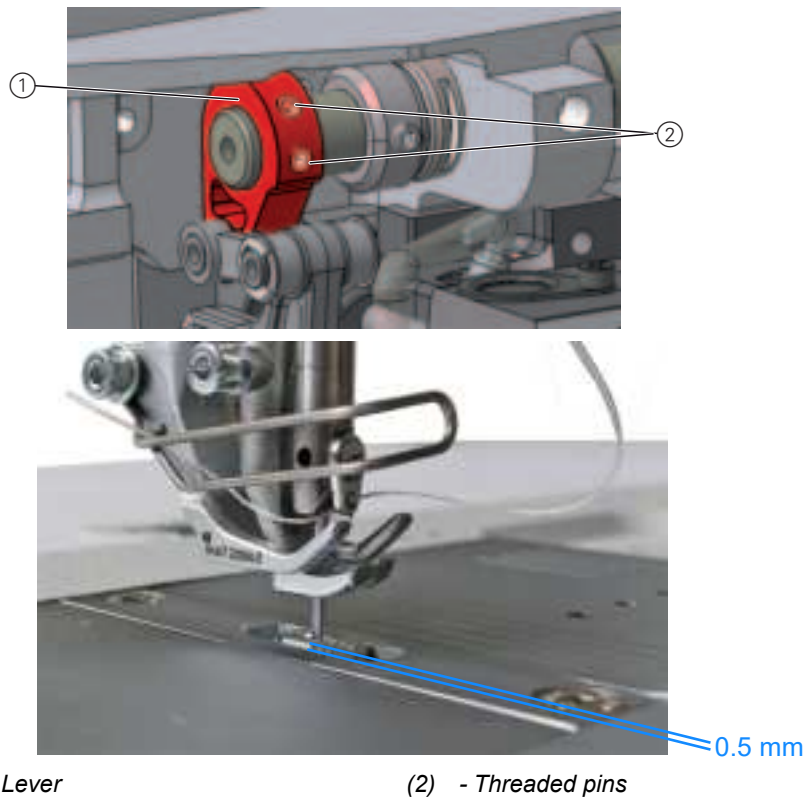

To adjust the feed dog height at top dead center:

1. Move the handwheel into the 185° position.
2. Loosen the threaded pins (2) for the lever (1).
3. Turn the lever (1) such that the upper edge of the feed dog protrudes 0.5 mm (KFA = 0.8 mm) above the throat plate.
4. Tighten the threaded pins (2).

## 9 Aligning the needle bar linkage

### CAUTION



#### Risk of injury from moving parts!

Crushing possible.

Switch off the machine before aligning the needle bar linkage.



#### Order

First, check the following setting:

- A straight and undamaged needle has to be inserted (📖 *Operating Instructions*)



#### Proper setting

1. Set the stitch length adjusting wheel to **0**.
- ↪ The needle pierces exactly in the center of the feed dog needle hole.

### 9.1 Aligning the needle bar linkage sideways



#### Cover

- Removing the arm cover (📖 p. 15)
- Removing the head cover (📖 p. 16)
- Disassembling the tensioning plate (📖 p. 20)
- Removing the front cover (📖 p. 18)

Fig. 37: Aligning the needle bar linkage sideways (1)

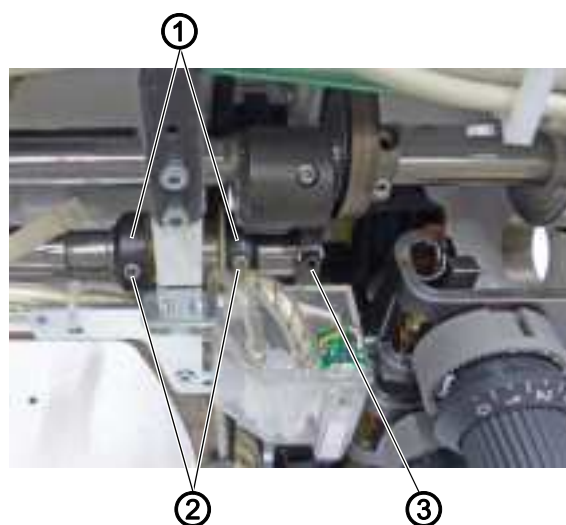

- (1) - Set collars  
(2) - Threaded pins

- (3) - Screw



To align the needle bar linkage sideways:

1. Set the stitch length adjusting wheel to **0**.
2. Loosen the threaded pins (2) on the two set collars (1) at the right-hand end of the shaft for the needle bar linkage.
3. Loosen the screw (3).

Fig. 38: Aligning the needle bar linkage sideways (2)

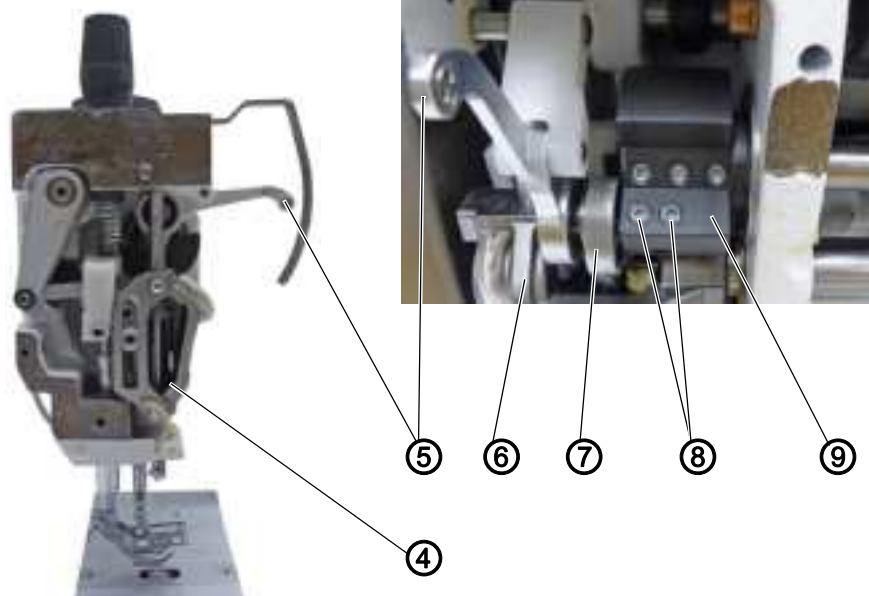

- (4) - Needle bar linkage
- (5) - Thread lever
- (6) - Crosshead

- (7) - Sliding block guide
- (8) - Threaded pins
- (9) - Arm shaft crank



4. Loosen the threaded pins (8) on the arm shaft crank (9). Make sure that the threaded pins stay on the surface.
5. Move the needle bar linkage (4) sideways such that the needle pierces exactly in the center of the needle hole for the feed dog.
6. Push the set collars (1) inwards as far as they will go and tighten them.
7. Tighten the threaded pins (2) on the two set collars (1).

Fig. 39: Aligning the needle bar linkage sideways (3)





8. Align the thread lever (5) relative to the arm shaft crank (9).
  - ↳ There is an equal amount of space on either side between the cross-head (6) and the sliding block guide (7).  
Once the tensioning plate has been assembled, the thread lever (5) is positioned in the center of the slot.
9. Tighten both threaded pins (8) on the arm shaft crank (9).

**Order**

Then check the following settings:

- Distance between hook and needle ( p. 58)

## 9.2 Aligning the needle bar linkage in the sewing direction



### Cover



- Removing the front cover ( p. 18)
- Tilting the machine head ( p. 14)

Fig. 40: Aligning the needle bar linkage in the sewing direction



(1) - Screw

(2) - Needle bar linkage

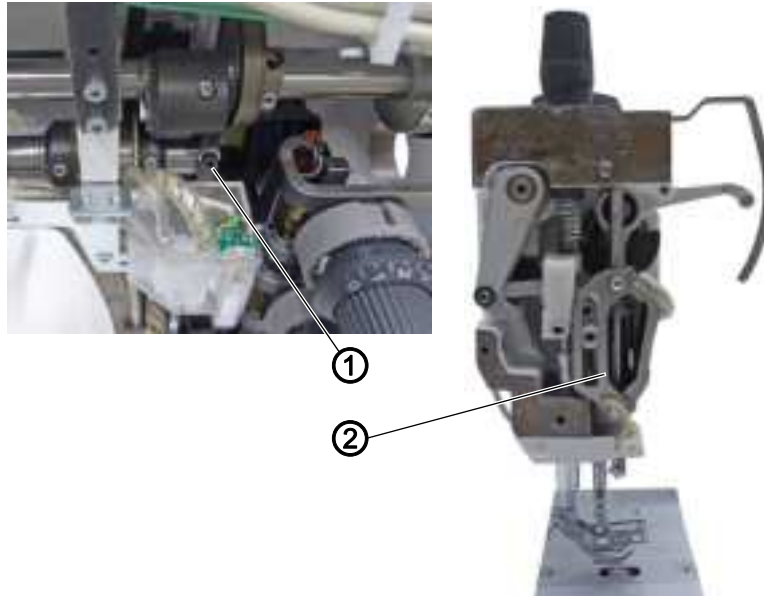

To align the needle bar linkage in the sewing direction:

1. Loosen the screw (1).
2. Move the needle bar linkage (2) such that the needle pierces in the center of the needle hole.
3. Tighten the screw (1).



### Order

Then check the following setting:

- Looping stroke position ( p. 60)

## 10 Position of the hook and needle

### CAUTION



#### Risk of injury from sharp and moving parts!

Puncture or crushing possible.

Switch off the machine before adjusting the hook and needle settings.

### 10.1 Adjusting the hook side clearance

#### NOTICE

#### Property damage may occur!



There is a risk of machine damage, needle breakage or damage to the thread if the distance between hook and needle tip is incorrect.

Check and, if necessary, readjust the distance to the hook tip after inserting a new needle with a different size.



#### Order

First, check the following settings:

- A straight and undamaged needle has been inserted ( *Operating Instructions*)
- Needle bar linkage ( *p. 54*)



#### Proper setting

The distance between the hook tip and the groove of the needle is 0.1 mm.



#### Cover



- Tilting the machine head ( *p. 14*)
- Opening the throat plate slide ( *p. 23*)

Fig. 41: Adjusting the hook side clearance (1)



- |                     |                |
|---------------------|----------------|
| (1) - Set collar    | (4) - Screws   |
| (2) - Threaded pins | (5) - Groove   |
| (3) - Hook support  | (6) - Hook tip |



To adjust the hook side clearance:

1. Loosen the screws (4).
2. Loosen the threaded pins (2) for the set collar (1).

Fig. 42: Adjusting the hook side clearance (2)

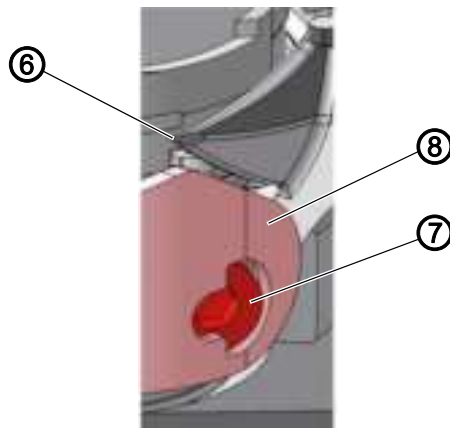



- |                |                    |
|----------------|--------------------|
| (6) - Hook tip | (8) - Needle guard |
| (7) - Screw    |                    |



3. Turn the screw (7) clockwise to swivel down the needle guard (8).
4. Move the hook support (3) sideways such that the distance between the hook tip (6) and the groove for the needle (5) is 0.1 mm at most, without the hook tip (6) touching the needle.
5. Tighten the screws (4).



### Important

6. Lock the machine in place at the looping stroke position (5 mm, ( p. 60)).
7. Tighten the threaded pins (2) for the set collar (1).
8. Remove the lock ( p. 27).



**Order**

Then check the following setting:

- Position of the needle guard (📖 p. 63)

**10.2 Adjusting the looping stroke position**

The looping stroke is the path length from the bottom dead center of the needle bar up to the position where the hook tip is exactly on the vertical center line of the groove for the needle.

**Checking the position of the hook tip**



**Order**

First, check the following settings:

- Needle bar linkage (📖 p. 54)
- A straight and undamaged needle has to be inserted (📖 *Operating Instructions*)



**Proper setting**

1. Lock the machine in place at position 1 (5 mm, (📖 p. 27)).
- ↪ The hook tip (2) points exactly to the vertical center line (1) of the needle.  
The looping stroke is precisely 2 mm.



**Disturbance**

- Skip stitches

Fig. 43: Checking the position of the hook tip

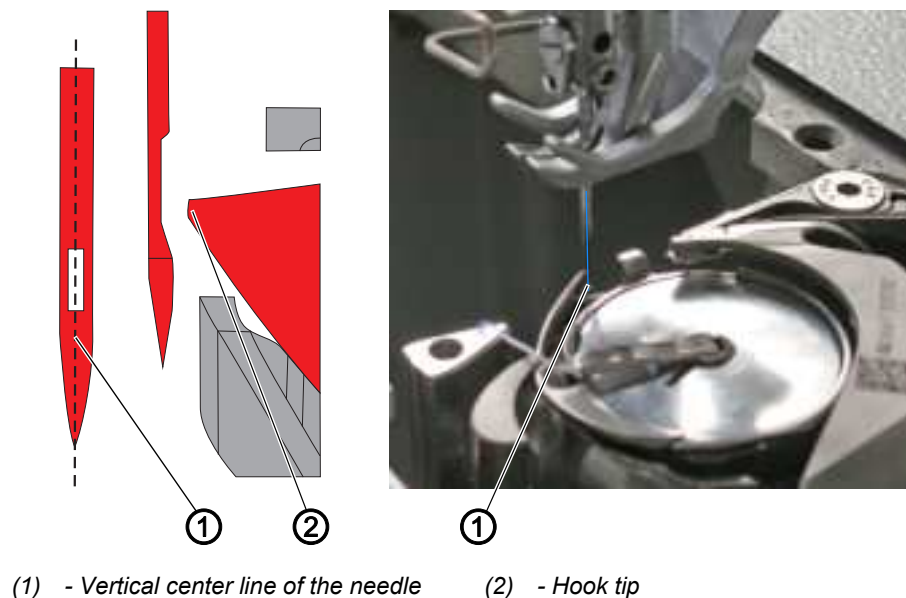

## Adjusting the looping stroke position



### Cover



- Tilting the machine head ( p. 14)
- Disassembling the throat plate ( p. 24)
- Disassembling the feed dog ( p. 25)

Fig. 44: Adjusting the looping stroke position



(1) - Set collar

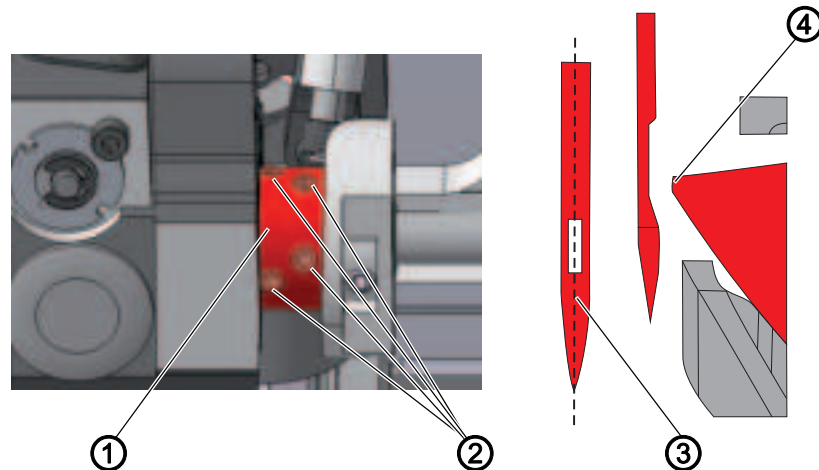

(2) - Threaded pins

(3) - Vertical center line of the needle

(4) - Hook tip





To adjust the looping stroke position:

1. Lock the machine in place at position **1** (5 mm, ( p. 27)).
2. Set the stitch length adjusting wheel to **0**.
3. Loosen the threaded pins (2) for the set collar (1).
4. Turn the hook such that the hook tip (4) points exactly to the vertical center line of the needle (3).
5. Tighten the threaded pins (2) for the set collar (1).
6. Remove the lock ( p. 27).



### Order

Then check the following settings:

- Position of the needle guard ( p. 63)
- Timing of cutting by the thread trimmer ( p. 85)

### 10.3 Adjusting the needle bar height



#### Order

First, check the following settings:

- Looping stroke position (📖 p. 60)
- A straight and undamaged needle has to be inserted (📖 *Operating Instructions*)



#### Proper setting

1. Lock the machine in place at position **1** (5 mm, (📖 p. 27)).
  2. Set the stitch length adjusting wheel to **0**.
- 👉 The hook tip is level with the lower third of the groove on the needle.



#### Disturbance

- Damage to the hook tip
- Jamming of the needle thread
- Skip stitches
- Thread breaking
- Needle breakage



#### Cover

- Removing the head cover (📖 p. 16)

Fig. 45: Adjusting the needle bar height

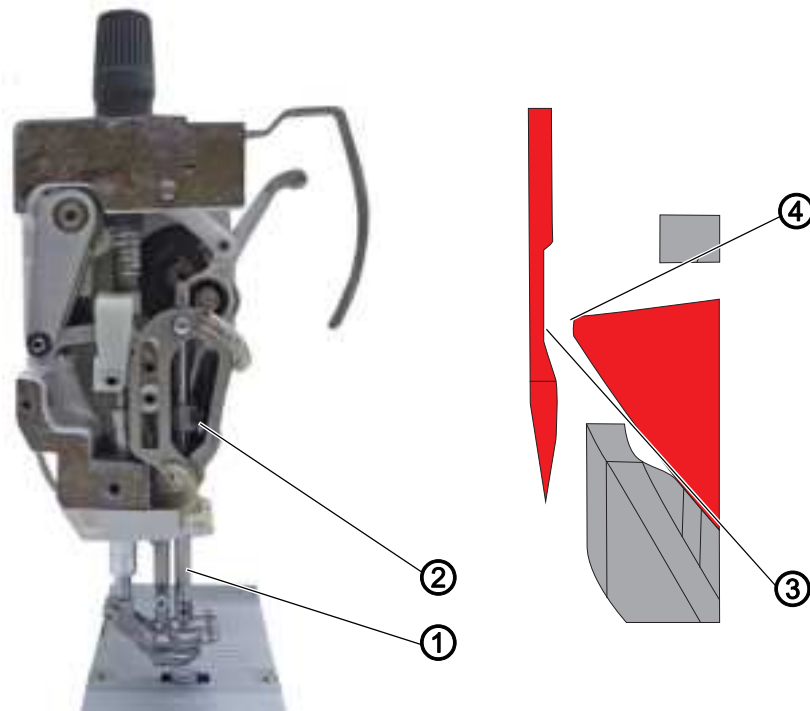

(1) - Needle bar  
(2) - Screw

(3) - Groove  
(4) - Hook tip



To adjust the needle bar height:

1. Lock the machine in place at position **1** (5 mm, ( p. 27)).
2. Set the stitch length adjusting wheel to **0**.
3. Loosen the screw (2) of the needle bar (1).
4. Move the height of the needle bar (1) such that the hook tip (4) is level with the lower third of the groove for the needle.



### Important

When doing so, take care not to twist the needle bar to the side. The groove (3) must face toward the hook.

5. Tighten the screw (2) for the needle bar (1).
6. Remove the lock ( p. 27).



### Order

Then check the following setting:

- Position of the needle guard ( p. 63)

## 10.4 Adjusting the needle guard

### NOTICE

#### Property damage may occur!

There is a risk of machine damage, needle breakage or damage to the thread if the distance between needle groove and hook tip is incorrect.





Check and, if necessary, readjust the distance to the hook tip after inserting a new needle with a different size.

The needle guard prevents contact between needle and hook tip.





### Order

First, check the following settings:

- Looping stroke position ( p. 60)
- Hook side clearance ( p. 58)
- Needle bar height ( p. 62)
- A straight and undamaged needle has to be inserted ( *Operating Instructions*)



### Proper setting

1. Lock the machine in place at position **1** (5 mm, ( p. 27)).
-  The needle guard pushes the needle just enough away so that it cannot be touched by the hook tip.



**Cover**

- Disassembling the feed dog (📖 p. 25)

Fig. 46: Adjusting the needle guard

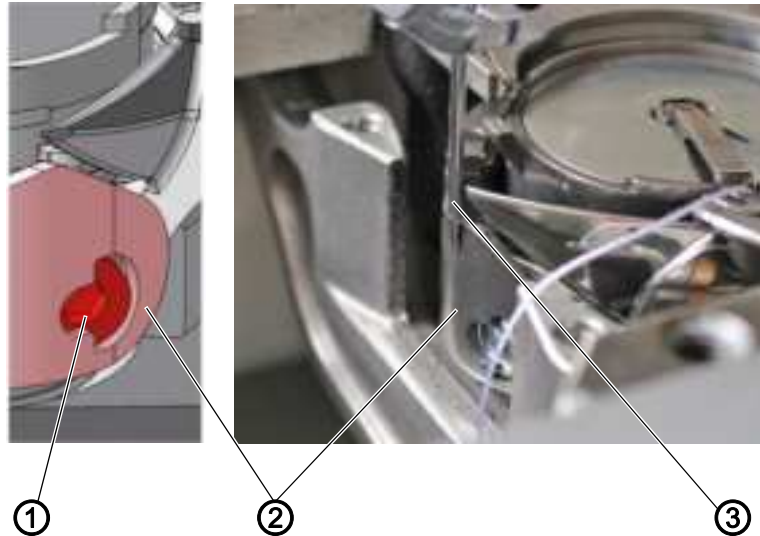

(1) - Screw

(2) - Needle guard

(3) - Needle



To adjust the needle guard:

1. Turn the handwheel and check how far the needle guard (2) pushes the needle away.
2. Turn the screw (1) such that the needle guard (2) just pushes the needle (3) far away enough so that it cannot be touched by the hook tip:
  - **For pushing away more:** Turn counterclockwise
  - **For pushing away less:** Turn clockwise

## 11 Adjusting the bobbin case lifter

### CAUTION



#### Risk of injury from moving parts!

Crushing possible.

Switch off the machine before adjusting the bobbin case lifter.

Fig. 47: Adjusting the bobbin case lifter



(1) - Bobbin case  
(2) - Bobbin case lifter

(3) - Nose of the bobbin case  
(4) - Slot in the throat plate

The hook pulls the needle thread through between the nose of the bobbin case (3) and the slot in the throat plate (4).

The bobbin case lifter (2) now pushes the bobbin case (1) away so that a gap appears for the thread.

If the hook tip is located below the bobbin case lifter, the bobbin case lifter must open so that the thread can also slide past in that position.

So that the thread can slip through without a problem, the width of the lifting gap and the timing of opening have to be adjusted.



### Disturbance

- Thread breaking
- Formation of loops on the bottom side of the seam
- Loud machine noise

## 11.1 Adjusting the lifting gap



### Order

Always check the width of the lifting gap after making changes to the needle thread size. The correct width of the lifting gap depends on the thickness of the needle thread.



### Proper setting

The needle thread slides through unobstructed between the nose of the bobbin case and the slot in the throat plate.



### Cover

- Tilting the machine head (📖 p. 14)
- Opening the throat plate slide (📖 p. 23)

Fig. 48: Adjusting the lifting gap

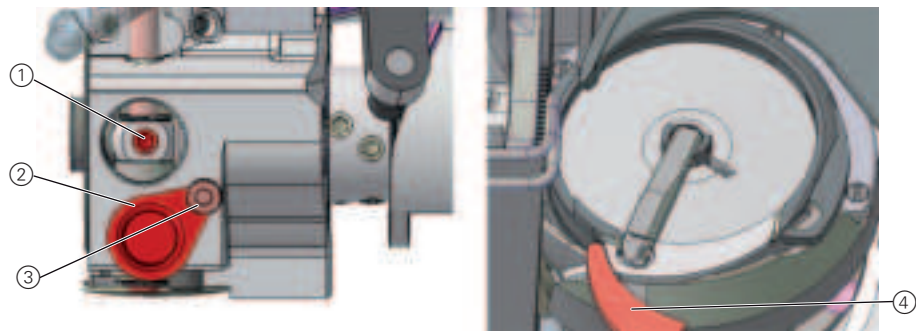

(1) - Threaded pin  
(2) - Cover

(3) - Screw  
(4) - Bobbin case lifter



To adjust the lifting gap:

1. Loosen the screw (3).
2. Push the cover (2) downwards.
3. Loosen the threaded pin (1).
4. Adjust the bobbin case lifter such that the gap between the nose of the bobbin case and the slot in the throat plate is just big enough to allow the needle thread to slip through without a problem



### Important

Ensure that the gap is not so big that the bobbin case swings back and forth, hitting the slot of the throat plate.

5. Tighten the threaded pin (1).
6. Push the cover (2) upwards.
7. Tighten the screw (3).

## 11.2 Adjusting the timing for opening



### Cover

- Tilting the machine head ( p. 14)

Fig. 49: Adjusting the timing for opening



(1) - Plug

(2) - Hook housing

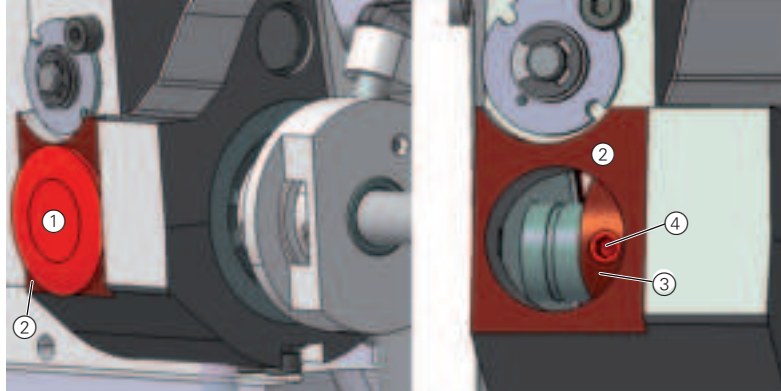
(3) - Control cam

(4) - Threaded pin



### Proper setting

The threaded pin (4) is exactly in the center of the slot (insert allen key in the threaded pin for orientation).

In 1-needle machines, this happens when the handwheel position is approx. 110°.

In 2-needle machines, this happens when the handwheel position is 110° for the right-hand hook, and when the handwheel position is 270° for the left-hand hook.



To adjust the timing for opening:

1. Remove the plug (1) on the bottom side of the hook housing (2).
2. Turn the handwheel to 110°.
  - ↳ The threaded pin (4) is exactly in the center of the slot at the right hook.
3. In 2-needle machines, turn the handwheel to 270°.
  - ↳ The threaded pin (4) is exactly in the center of the slot at the left hook.
4. Insert the plug (1) into the opening.

## 12 Sewing feet

### CAUTION



**Risk of injury from sharp and moving parts!**

Puncture or crushing possible.

Switch off the machine before adjusting the sewing feet settings.

Fig. 50: Sewing feet

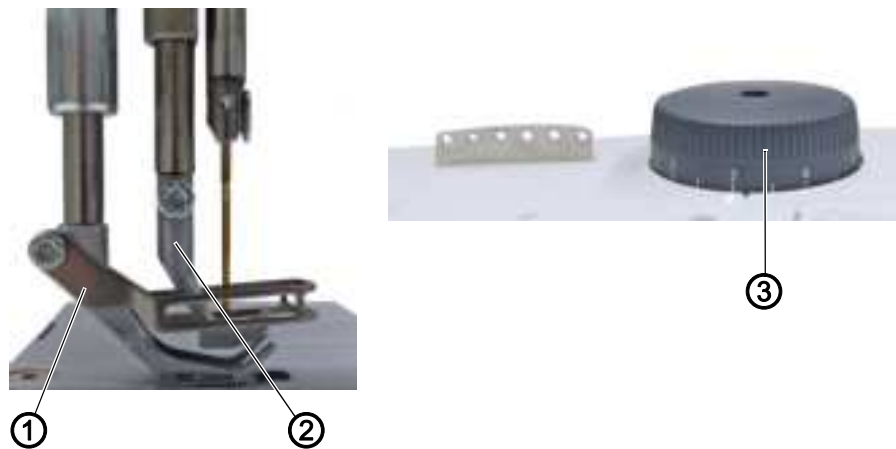

(1) - Presser foot  
(2) - Walking foot

(3) - Sewing foot stroke adjusting wheel

The adjusting wheel (3) on the machine arm determines how high the presser foot (1) and walking foot (2) are raised during the sewing process.

### 12.1 Adjusting the eccentric for the top feed stroke

#### Checking the stroke movement for the walking foot

In order to ensure a correct feed, the stroke movement for the walking foot must be aligned to the stroke movement for the feed dog.



#### Order

First, check the following settings:

- Feed dog movement (📖 p. 49)
- Even sewing foot stroke (📖 p. 70)



### Proper setting

1. Position the adjusting wheel for the sewing foot stroke **9** and the stitch length adjusting wheel to **0**.
- ↪ The walking foot (1) touches down exactly on the feed dog (2) when the downward movement of the needle tip (3) reaches the upper edge of the walking foot. This will occur when the handwheel is in the 95° position.

Fig. 51: Checking the stroke movement for the walking foot

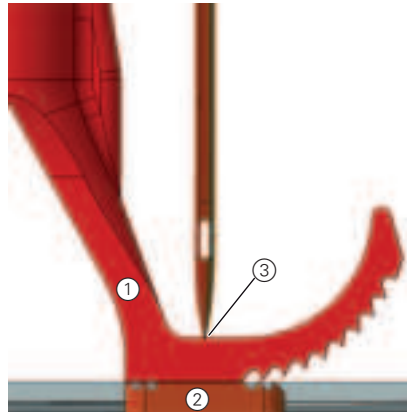

(1) - Walking foot  
(2) - Feed dog

(3) - Needle tip

### Adjusting the eccentric



#### Cover

- Removing the front cover (📖 p. 18)

Fig. 52: Adjusting the walking foot movement



(1) - Screw  
(2) - Eccentric

(3) - Marking  
(4) - Marking



To adjust the stroke movement for the walking foot:

1. Lock the machine in place at position **1** (5 mm, ( p. 27)).
2. Loosen the 2 screws (1) on the eccentric (2).
3. Turn the eccentric (2) until the markings (3) and (4) are parallel to one another.
4. Tighten the screws (1).
5. Remove the lock.

## 12.2 Adjusting an even sewing foot stroke

### NOTICE

#### Property damage may occur!

Machine can be damaged if the adjusting wheels are forced.

Do not attempt to use force to set a smaller sewing foot stroke at the right adjusting wheel.



#### Proper setting

For sewing foot stroke **3**, the presser foot and walking foot are raised by the same height.



#### Cover

- Removing the arm cover ( p. 15)

Fig. 53: Adjusting an even sewing foot stroke



- (1) - Presser foot  
(2) - Walking foot

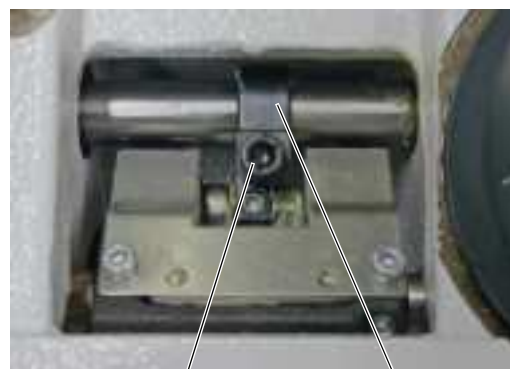

- (3) - Screw  
(4) - Sewing foot lever



To adjust an even sewing foot stroke:

1. Check the sewing foot stroke.
2. Loosen the screw (3).
3. Push the walking foot (2) down slightly by hand.

4. Tighten the screw (3).
5. Turn the handwheel and check if the presser foot (3) and the walking foot (2) are at the same height.  
If this is not the case, adjust the walking foot (2) until the movement is correct.

### 12.3 Adjusting the adjusting frame

Fig. 54: Adjusting the adjusting frame

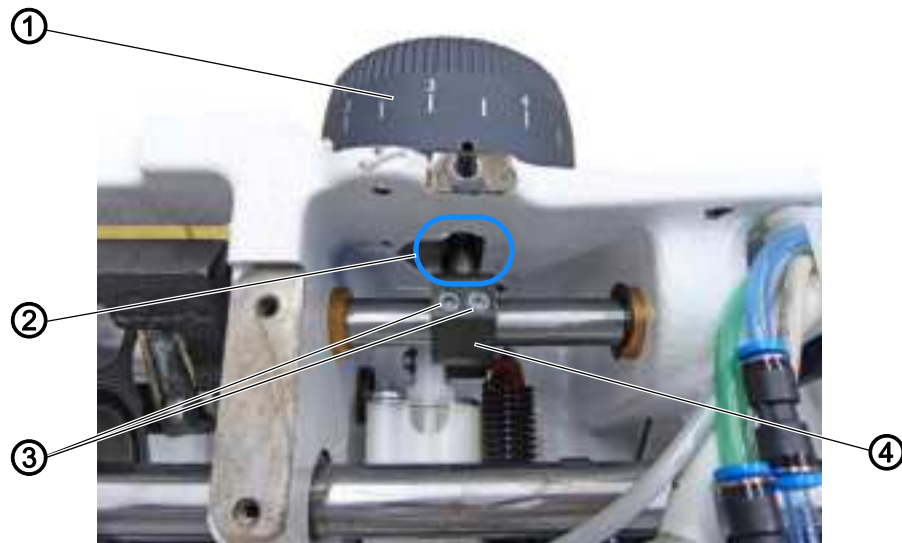

- |  |                    |
|--|--------------------|
| (1) - Sewing foot stroke adjusting wheel | (3) - Screws       |
| (2) - Slot                               | (4) - Stroke lever |



To adjust the adjusting frame:

1. Turn the handwheel to the 0° position.
2. Place a 3 mm allen key under the walking foot.
3. Loosen the screws (3).
4. Position the adjusting wheel for the sewing foot stroke (1) to level 3.
5. Manually lower the walking foot down onto the allen key.
6. Center the stroke lever (4) in the slot (2).
7. Tighten the screws (3).



#### Important

8. Ensure that the stroke lever (4) does not shift.

## 12.4 Adjusting the sewing foot lifting height

### CAUTION



#### Risk of injury from moving parts!

The machine must remain switched on so that the sewing feet can be raised.  
Crushing possible

Exercise particular caution when adjusting the sewing foot lifting height.  
Do not put your hands under the sewing feet when they are being lowered.

When the pedal is pressed back halfway, the sewing feet can be raised during sewing, e. g. to move the sewing material.

When the pedal is pressed completely back, the sewing feet will be raised after the thread is cut so that the sewing material can be exchanged.



#### Proper setting

The distance between the raised sewing feet and the throat plate is preset to 20 mm on delivery.



#### Cover

- Removing the rear cover ( p. 17)

Fig. 55: Adjusting the sewing foot lifting height



(1) - Counternut

(2) - Adjusting wheel



To adjust the lifting height of the sewing foot:

1. Loosen the counternut (1) for the adjusting wheel (2).

2. Turn the adjusting wheel (2) to adjust the distance between the raised sewing feet and the throat plate:
  - **To raise the sewing feet to a lesser height:** Turn clockwise
  - **To raise the sewing feet higher:** Turn counterclockwise
3. Tighten the counternut (1) for the adjusting wheel (2).

### 13 Adjusting the thread tensioning spring

The thread tensioning spring holds the needle thread under tension from the top dead center of the thread lever up to the point when the needle eye plunges into the sewing material.



#### Proper setting

**Initial position:** The thread tensioning spring does not contact the stop until the needle eye has plunged into the sewing material.



#### Important

The adjustment for the thread tensioning spring must be varied according to the sewing material and the required sewing result.

Fig. 56: Adjusting the thread tensioning spring



(1) - Spring

(2) - Tension disk

(3) - Screw

(4) - Stop collar



To adjust the thread tensioning spring:

1. Loosen the screw (3).
2. Adjusting the spring travel: Turn the stop collar (4):
  - **Longer spring travel:** Turn counterclockwise
  - **Shorter spring travel:** Turn clockwise
3. Adjusting the spring tension: Turn the tension disk (2):
  - **Greater spring tension:** Turn counterclockwise
  - **Less spring tension:** Turn clockwise



#### Important

Do not twist the stop collar (4) when doing so.

4. Tighten the screw (3).

## 14 Winder

### 14.1 Adjusting the winder

#### CAUTION



**Risk of injury from moving parts!**

Crushing possible.

Switch off the machine before adjusting the winder.



#### Proper setting

The winder wheel runs smoothly and without axial play.

The winding process will stop automatically when the required filling quantity of the bobbin is reached.



#### Cover

- Removing the arm cover ( p. 15)

#### 14.1.1 Disassembling the winder

Fig. 57: Disassembling the winder



(1) - Screws



To disassemble the winder and set the winder filling quantity:

1. Loosen the screws (1).
2. Remove the winder.

### 14.1.2 Basic winder setting

Fig. 58: Basic winder setting



- (1) - Screw
- (2) - Winder lever

- (3) - Bobbin



#### Proper setting

The thread winds around the bobbin (3) and reaches the desired filling quantity.  
Minor changes of the filling quantity are adjusted by the winder lever (2) with screw (1).

### 14.1.3 Setting the winder run and automatic stop



#### Proper setting

The winder wheel runs smoothly and without axial play. The winding process stops automatically if the bobbin is filled to approx. 0.5 mm under the edge of the bobbin.

Fig. 59: Setting the winder run and automatic stop (1)



- (1) - Screw
- (2) - Winder lever
- (3) - Leaf spring
- (4) - Corner

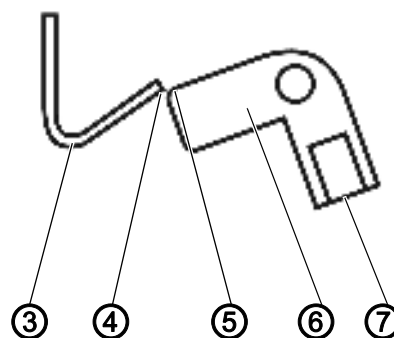

- (5) - Corner
- (6) - Switch cam
- (7) - Screw



To set the winder run and the automatic stop:



1. Disassembling the winder ( p. 75)
2. Tighten the screw (1) until the two shanks of the winder lever (2) are parallel to each other.
3. Put a completely filled bobbin onto the winder.
4. Turn the winder lever (2) such that the thread abuts on the bobbin.
5. Loosen the screw (7).

Fig. 60: Setting the winder run and automatic stop (2)



(8) - Block

(9) - Locking disk

6. Adjust the block (8) such that it is resting against the locking disk (9).
7. Adjust the switch cam (6) such that the corner (5) of the switch cam (6) and the corner (4) of the leaf spring (3) line up on top of each other  
 The spring is tensioned.
8. Adjust the switch cam (6) such that the winder lever (2) has no axial play.
9. Tighten the screw (7).

### 14.1.4 Assembling the winder

Fig. 61: Assembling the winder



(1) - Screws

(2) - Nose



To assemble the winder:

1. Place the winder on the machine arm.



**Information**

To position the winder correctly, place the nose (2) of the winder on the stitch length adjusting wheel.

2. Tighten the screws (1).

## 14.2 Adjusting the winder wheel



### Cover

- Removing the front cover ( p. 18)

Fig. 62: Adjusting the winder wheel

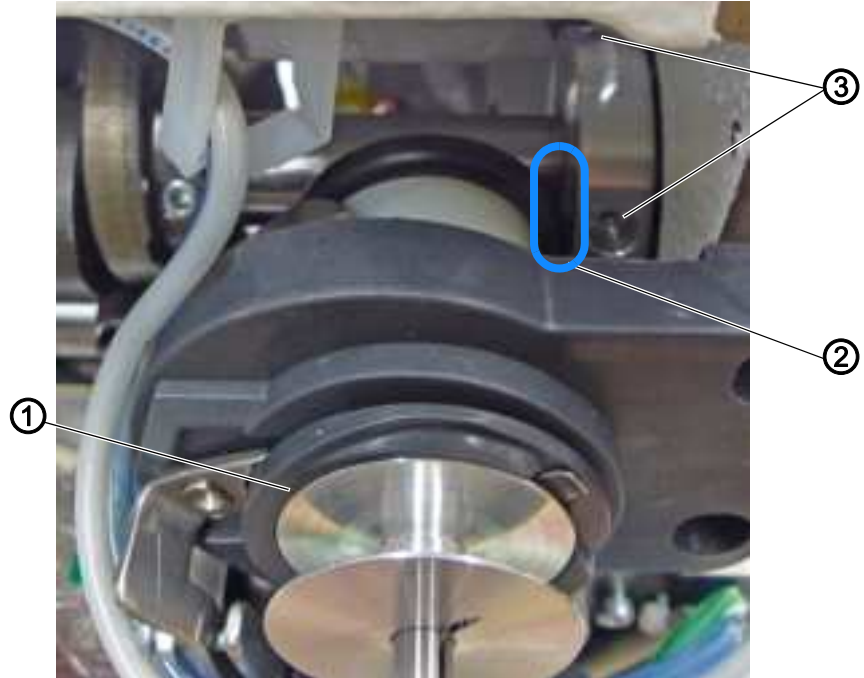

(1) - Winder  
(2) - Distance

(3) - Threaded pins



To adjust the winder wheel:

1. Loosen the threaded pins (3).
2. Switch off the winder (1).
3. Set the distance (2) between the wheels to 0.8 mm.
4. Tighten the threaded pins (3).

### 14.3 Adjusting the hook thread guide

The position of the hook thread guide determines how the thread is wound onto the winder.



#### Proper setting

The thread is wound on evenly over the entire width of the bobbin.

Fig. 63: Adjusting the hook thread guide



(1) - Screw

(2) - Hook thread guide



To adjust the hook thread guide:

1. Loosen the screw (1).
2. Turn the hook thread guide (2):
  - **To the front:** The thread will be wound on further to the front
  - **To the rear:** The thread will be wound on further to the rear

## 15 Thread trimmer

### CAUTION



**Risk of injury from sharp and moving parts!**

Puncture or crushing possible.

Switch off the machine before adjusting the thread trimmer.

### 15.1 Adjusting the height of the thread-pulling knife

The adjustment is made by means of washers between the knife carrier (3) and the thread-pulling knife (2). Surplus washers (5) are stored above the thread-pulling knife (2).



#### Important

When changing the knives, make sure that you do not lose the washers.



#### Proper setting

The thread-pulling knife (2) pivots as closely as possible above the hook and is positioned slightly higher than the counter blade (1).



#### Cover

- Opening the throat plate slide ( p. 23)

Fig. 64: Adjusting the height of the thread-pulling knife



- (1) - Counter blade  
(2) - Thread-pulling knife  
(3) - Knife carrier

- (4) - Screw  
(5) - Washer



To adjust the height of the thread-pulling knife:

1. Loosen the screw (4).
2. Remove the thread-pulling knife (2).
3. Place as many washers between thread-pulling knife (2) and knife carrier (3) as needed for the thread-pulling knife (2) to be positioned as close to the bobbin case as possible without coming into contact with the bobbin case.
4. Store non-required washers (5) on the top side between thread-pulling knife (2) and screw (4).
5. Tighten the thread-pulling knife (2) using the screw (4).

## 15.2 Adjusting the cutoff curve



### Proper setting

The control cam (4) makes direct contact with the set collar (1).

The distance between the widest extent (6) of the control cam (4) and the roller (3) is 0.1 mm at most.

In resting position, the circle mark on the cutting edge of the thread-pulling knife is exactly next to the tip of the counter blade.



### Cover

- Tilting the machine head (📖 p. 14)
- Opening the throat plate slide (📖 p. 23)

Fig. 65: Adjusting the cutoff curve (1)

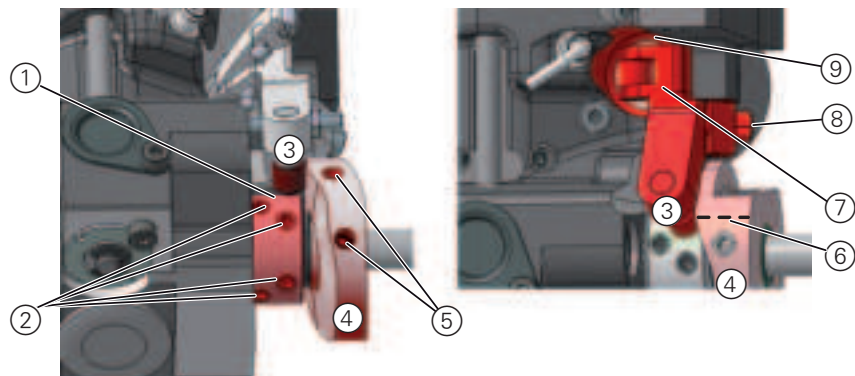

- (1) - Set collar
- (2) - Threaded pins
- (3) - Roller
- (4) - Control cam
- (5) - Threaded pins

- (6) - Widest extent
- (7) - Actuating lever
- (8) - Clamping screw
- (9) - Solenoid



To adjust the cutoff curve:

1. Loosen all 4 threaded pins (2) on the clamping ring (1).
2. Push the set collar (1) as far as it will go to the left.
3. Tighten all 4 threaded pins (2) on the clamping ring (1).



### Important

Tighten the 4 threaded pins (2) on the set collar (1) before you loosen the threaded pins (5). The set collar (1) and control cam (4) are both mutually used as a stop and should not be loosened at the same time.

4. Loosen the threaded pins (5).
5. Press the actuating lever (7) against the solenoid (9).
6. Turn the control cam (4) such that its widest extent (6) is at the top, next to the roller (3).
7. Move the control cam (4) such that the distance between its widest extent (6) and the roller (3) is 0.1 mm at most.
8. Tighten the threaded pins (5).
9. Loosen the clamping screw (8) on the actuating lever (7).

Fig. 66: Adjusting the cutoff curve (2)

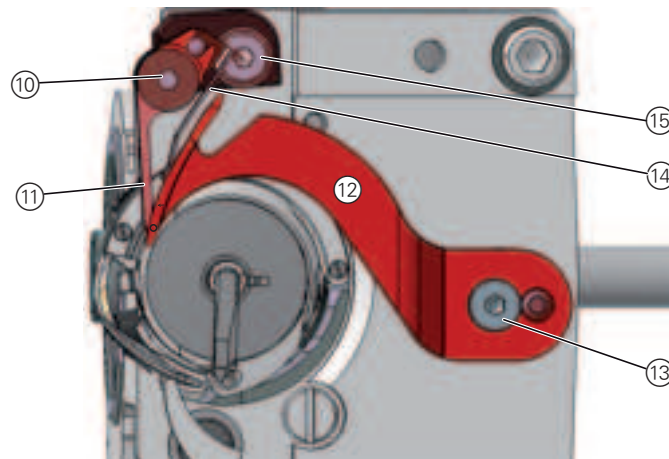

(10) - Screw

(11) - Counter blade

(12) - Thread-pulling knife

(13) - Screw

(14) - Hook thread clamp

(15) - Screw



10. Turn the thread-pulling knife (12) such that the circle mark is exactly next to the tip of the counter blade (11).
11. Tighten the clamping screw (8) on the actuating lever (7) such that the actuating lever (7) has no axial play.
12. Loosen all 4 threaded pins (2) on the clamping ring (1).
13. Push the set collar (1) to the right as far as it will go and against the control cam (4).



### Important

Check the looping stroke position ( p. 60).

14. Tighten all 4 threaded pins (2) on the clamping ring (1).

### 15.3 Adjusting the cutting pressure

The shape of the thread-pulling knife automatically creates the required cutting pressure as soon as the thread-pulling knife and counter blade make contact.



#### Proper setting

In resting position, the hook thread clamp makes contact with the thread-pulling knife without any pressure being applied. Any 2 threads with the greatest strength used for sewing can be neatly cut simultaneously.



#### Disturbance

- Increased knife wear when the pressure is too great
- Problems when sewing if the hook thread clamp is too high
- Problems in cutting the thread



#### Cover

- Opening the throat plate slide (📖 p. 23)

Fig. 67: Adjusting the cutting pressure

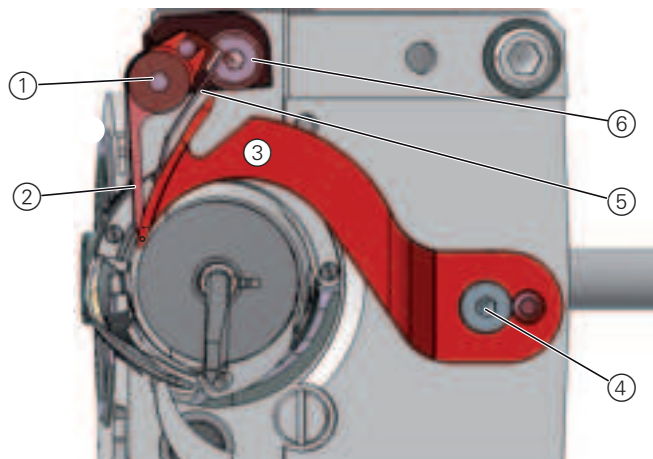

- |                            |                         |
|----------------------------|-------------------------|
| (1) - Screw                | (4) - Screw             |
| (2) - Counter blade        | (5) - Hook thread clamp |
| (3) - Thread-pulling knife | (6) - Screw             |



To adjust the cutting pressure:

1. Turn the handwheel until the thread-pulling knife (3) can be swung out by hand.
2. Loosen the screw (1).
3. Position the thread-pulling knife (3) such that the arrow mark is exactly next to the tip of the counter blade (2).
4. Turn the hook thread clamp (5) such that it rests against the thread-pulling knife (3).
5. Turn the counter blade (2) such that it rests against the thread-pulling knife (3).
6. Tighten the screw (1).



### Important

Check the position of the cutters, since the counter blade can easily become warped when the screw is being tightened.

## 15.4 Adjusting point in time for cutting



### Proper setting

The threads are cut when the thread lever is at the top dead center (hand-wheel position **60°**).



### Information

Additional setting for 2-needle machines:

The control cam for the right-hand needle or the right-hand hook support is identified by an **R** and an arrow for the direction of rotation.

The control cam for the left-hand needle or the left-hand hook support is identified by an **L** and an arrow for the direction of rotation.



### Cover



- Tilting the machine head ( p. 14)
- Opening the throat plate slide ( p. 23)

Fig. 68: Adjusting point in time for cutting



- |                   |                            |
|-------------------|----------------------------|
| (1) - Roller      | (4) - Threaded pins        |
| (2) - Set collar  | (5) - Counter blade        |
| (3) - Control cam | (6) - Thread-pulling knife |

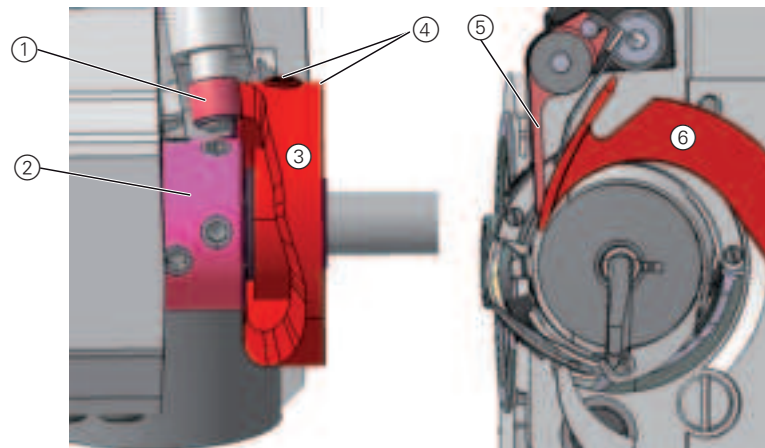

To adjust the point in time for cutting:

1. Loosen the threaded pins (4).
2. Turn the handwheel until the thread-pulling knife (6) can be swung out by hand.
3. Pivot the thread-pulling knife (6) as far forward until the circle mark is exactly next to the tip of the counter blade (5).
4. Set the handwheel position to **60°**.

5. Push the control cam (3) to the left as far as it will go and against the set collar (2).
6. Turn the control cam (3) such that the roller (1) runs up at the contour of control cam (3) and the widest extent of the control cam is at handwheel position **60°** at the highest point.
7. Tighten the threaded pins (4).
8. Check adjustment:
  - Insert the thread into the thread-pulling knife (6) and slowly turn the handwheel.
  - Check the handwheel position at which the thread is cut.
  - If necessary, repeat setting steps 1 – 7 until the cut takes place at **60°**.

## 16 Short thread trimmer

### CAUTION



#### **Risk of injury from sharp and moving parts!**

Puncture or crushing possible.

Switch off the machine before adjusting the short thread trimmer settings.

### NOTICE

#### **Property damage may occur!**

Risk of breakage.

The reverse-motion lock for the bobbin case is on the thread-pulling knife.



Never operate the machine without the thread-pulling knife.



#### **Important**

Correct setup of the short thread trimmer requires that the necessary work steps be performed in the order given in this chapter.

#### **Requirements**

- The needle bar must be at the top dead center when the handwheel position is **0°** ( p. 36)
- The hook bearing must be set correctly ( p. 58).

### Height of the thread-pulling knife

Fig. 69: Height of the thread-pulling knife

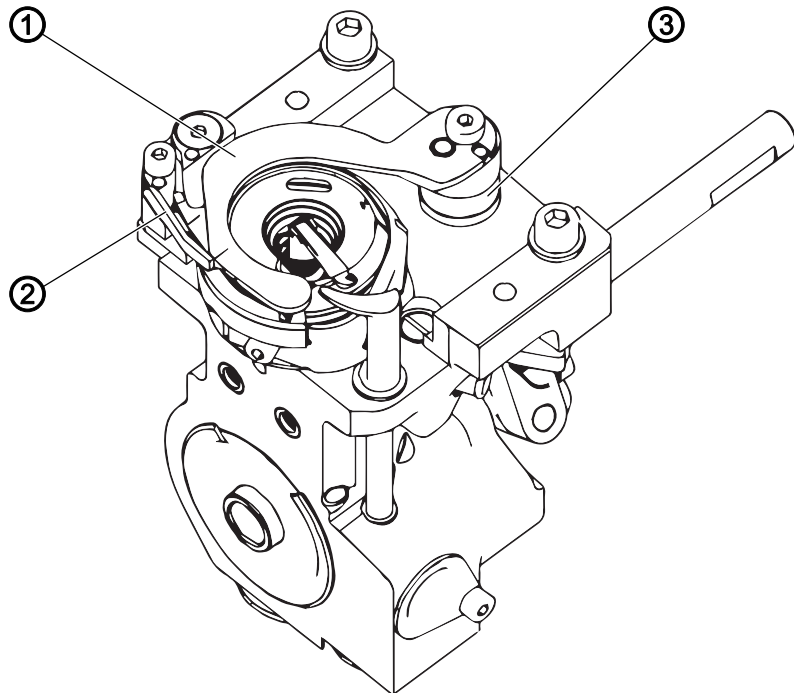

(1) - Thread-pulling knife  
(2) - Counter blade

(3) - Knife carrier

The height of the thread-pulling knife has been set at the factory using adjusting washers between thread-pulling knife (1) and knife carrier (3). When changing the knives, make sure that you do not lose the adjusting washers.



#### Important

The height of the thread-pulling knife is determined by the height of the counter blade. The upper edges of the two knives must be on the same level.

## Position of the thread-pulling knife

Fig. 70: Position of the thread-pulling knife

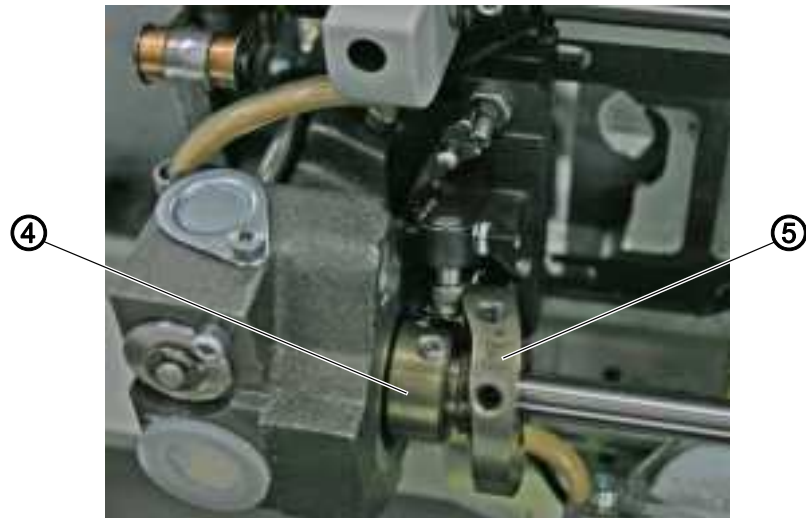

(4) - Set collar

(5) - Control cam

The thread-pulling knife (1) cannot be moved on the knife carrier (3). Therefore, you will not have to adjust the cutting pressure after replacing the thread-cutting knife (1).

The knife carrier (3) can be installed in 2 different positions: Large hook and XXL hook. To do this, the knife carrier (3) is rotated by 180°.

In resting position, the thread-pulling knife (1) completely covers the cutting edge of the counter blade (2). This prevents the needle thread from being damaged.

The pivot range of the thread-pulling knife is 23°.

The control cam (5) is designed for operating with the large hook and the XXL hook.

The control cam (5) can be on the right-hand side (label is right side up) or on the left side (label is upside down) of the set collar (4).



### Proper setting

The control cam (5) makes contact with the set collar (4). The label of the control cam (5) is correct in accordance with the installation situation.

## 16.1 Adjusting the locking latch



### Proper setting

1. Turn the handwheel until the roller (2) is at the highest point of the control cam (3).
  2. Press the roller (2) against the control cam (3).
- ⚠ The locking latch (1) can be swung out without clamping, and the distance between the locking latch (1) and locking pin (6) is no greater than 0.1 mm.

Fig. 71: Adjusting the locking latch

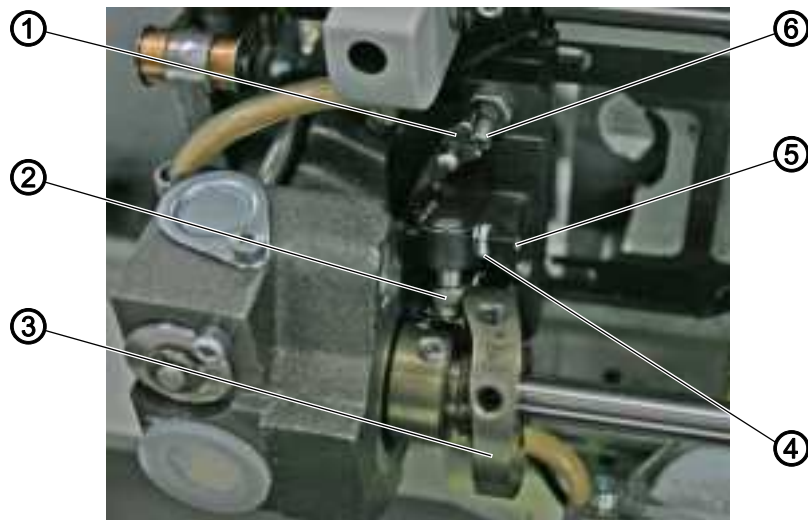

- (1) - Locking latch  
 (2) - Roller  
 (3) - Control cam

- (4) - Nut  
 (5) - Screw  
 (6) - Locking pin



To adjust the locking latch:

1. Loosen the nut (4).
2. Turn the screw (5) and adjust the distance.
3. Tighten the nut (4).

## 16.2 Adjusting the thread-pulling knife



### Proper setting

When the thread-pulling knife (1) is at rest, the distance between the highest point of the control cam (7) and the roller (5) is 0.1 mm

The control cam (7) makes contact with the clamping ring (6)

The marking (3) on the thread-pulling knife (1) is adjacent to the cutting edge of the counter blade (2)

The knife carrier (4) must have no axial play, but still run smoothly

Fig. 72: Adjusting the thread-pulling knife

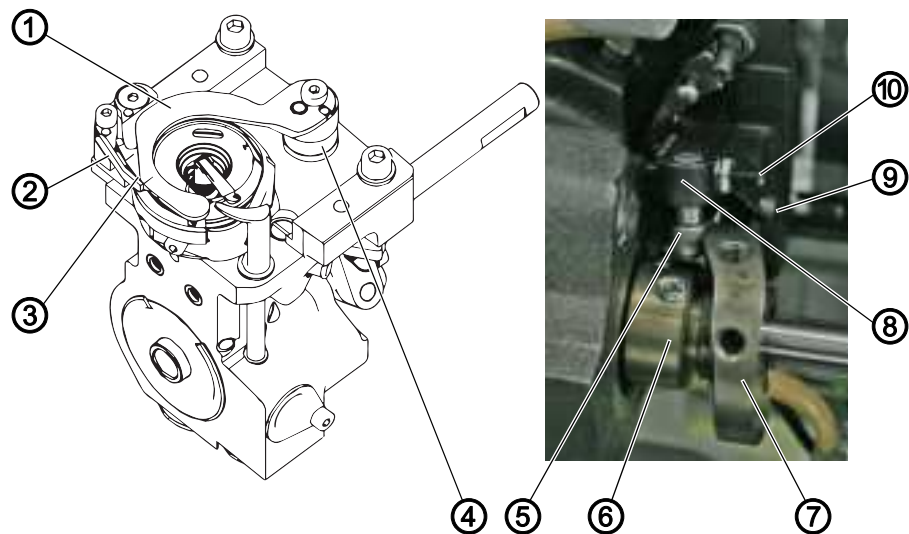

- (1) - Thread-pulling knife
- (2) - Counter blade
- (3) - Marking
- (4) - Knife carrier
- (5) - Roller

- (6) - Set collar
- (7) - Control cam
- (8) - Lever
- (9) - Clamping screw
- (10) - Screw



To adjust the thread-pulling knife:

1. Loosen all 4 screws on the clamping ring (6) and push the clamping ring (6) toward the hook bearing.
2. Tighten all 4 screws on the set collar (6).
3. Loosen both threaded pins on the control cam (7).
4. Turn the lever (8) as far as it will go against the screw (10).
5. Set the distance between the roller (5) and the highest point of the control cam (7) to 0.1 mm.
6. Tighten both threaded pins on the control cam (7).
7. Loosen the clamping screw (9) on the lever (8).
8. Turn the thread-pulling knife (1) until the marking (3) on the cutting edge of the counter blade (2) is adjacent to it.
9. Tighten the clamping screw (9).  
Take care to ensure that there is no axial play.

10. Loosen all 4 screws (6) on the set collar and push the set collar (6) as far as it will go and against the control cam (7).
11. Tighten all 4 screws on the set collar (6).
12. Check the looping stroke (📖 p. 60).

### 16.3 Adjusting the counter blade



#### Proper setting

The thread must be reliably cut using little pressure. The pressure is built up starting at the marking (2).

Any 2 threads with the greatest strength used for sewing can be neatly cut simultaneously.

Fig. 73: Adjusting the counter blade

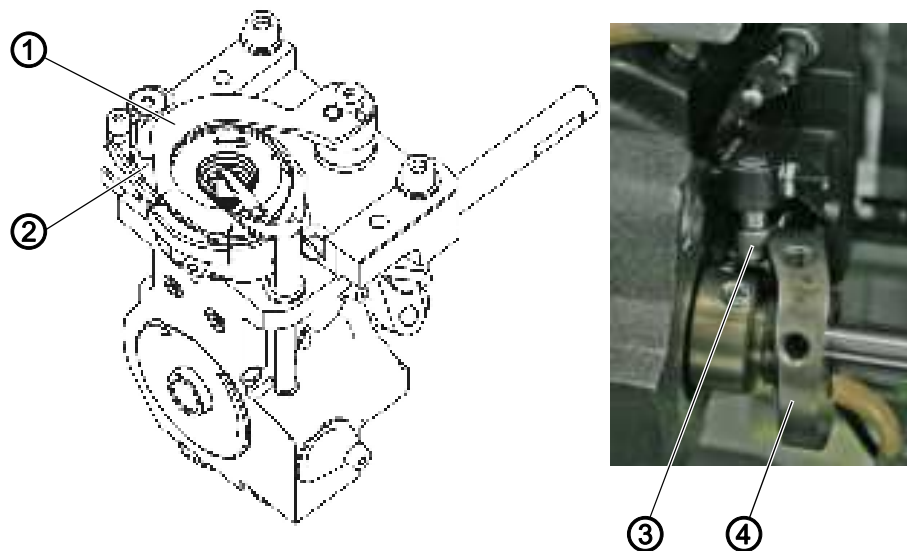

(1) - Thread-pulling knife  
(2) - Marking

(3) - Roller  
(4) - Control cam



To adjust the counter blade:

1. Turn the handwheel until the thread-pulling knife (1) can be swung out after the latch is triggered.
2. Swing out the thread-pulling knife (1) manually. To do this, press the block with the roller (3) to the right against the control cam (4).
3. Insert 2 threads into the thread-pulling knife (1).
4. Turn the handwheel until the knife swivels down.
5. Check whether the sewing threads have been cleanly cut and pressure is built up starting at the marking (2).



#### Disturbance

- Increased knife wear when the pressure is too great
- Problems in cutting the thread

## Adjusting the cutting pressure



### Cover

- Opening the throat plate slide ( p. 23)

Fig. 74: Adjusting the cutting pressure



(1) - Thread-pulling knife  
(2) - Marking

(3) - Counter blade  
(4) - Screw

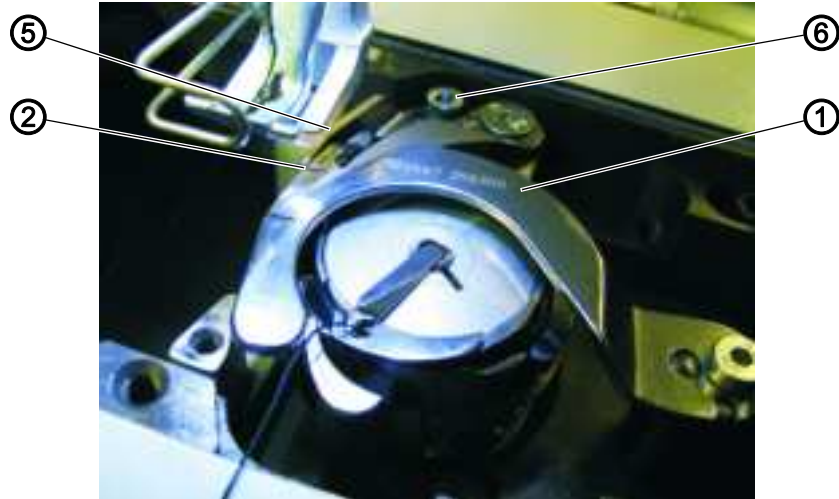

To adjust the cutting pressure:

1. Swing out the thread-pulling knife (1) until the marking (2) is next to the cutting edge of the counter blade (3).
2. Loosen the screw (4).
3. Place the counter blade (3) in position against the thread-pulling knife (1).
4. Tighten the screw (4).

## 16.4 Adjusting the cutoff position



### Proper setting

The default is that the cutting position is at the **65°** position on the handwheel (thread lever at top dead center). When the machine is at the **65°** position on the handwheel, the control cam (5) is at its highest point.

Fig. 75: Adjusting the cutoff position

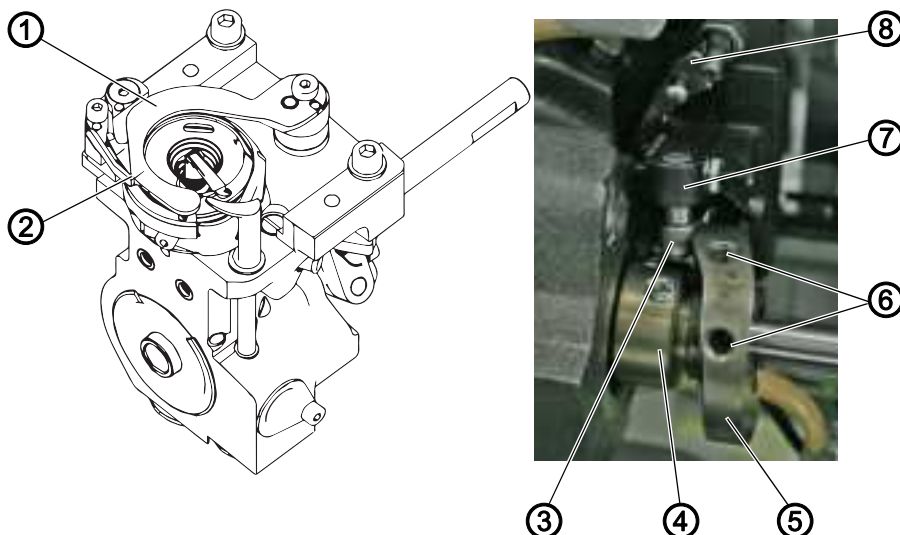

(1) - Thread-pulling knife  
(2) - Marking  
(3) - Roller  
(4) - Set collar

(5) - Control cam  
(6) - Threaded pins  
(7) - Lever  
(8) - Locking latch



To check the cutoff position:

1. Turn the handwheel to the **0°** position (needle bar at top dead center).
2. Loosen the locking latch (8).
3. Swing out the thread-pulling knife (1) manually. To do this, press the lever (7) with the roller (3) to the right against the control cam (5).
4. Insert a thread into the thread-pulling knife (1).
5. Use the handwheel to turn the machine until the thread is cut shortly before reaching the marking (2).
6. Check if the cut was made at the **65°** position on the handwheel.



To adjust the cutoff position:

1. Loosen the threaded pins (6) on the control cam (5).
2. Move the control cam (5) towards the set collar (4) until it makes contact and correct the position of the control cam (5).
3. Tighten the threaded pins (6) on the control cam (5) again.
4. Check the position as described above under **Proper setting** and correct the position again if necessary.

## 17 Adjusting the potentiometer

### WARNING



#### Increased risk of injury!

The machine remains switched on when the potentiometer is set.  
Puncture or crushing possible

Carry out all work with great caution.

The potentiometer adjusts the s.p.m. to the set sewing foot stroke and reduces the s.p.m. if the sewing foot stroke is too much.



#### Proper setting

After accessing the technician level, the left display will show 1 in the first instance and the relevant maximum speed next to it.



#### Cover



- Removing the front cover ( p. 18)
- Removing the control panel ( p. 19)

Fig. 76: Adjusting the potentiometer (1)





To adjust the potentiometer:

The potentiometer is set at technician level  $t\ 10\ 04$ .  
If the display indicates a different level:



1. Call up the technician level ( p. 113):

Use  and  to set the parameter  $t\ 10\ 04$ .

↳ Display of current level and corresponding speed.

Fig. 77: Adjusting the potentiometer (2)

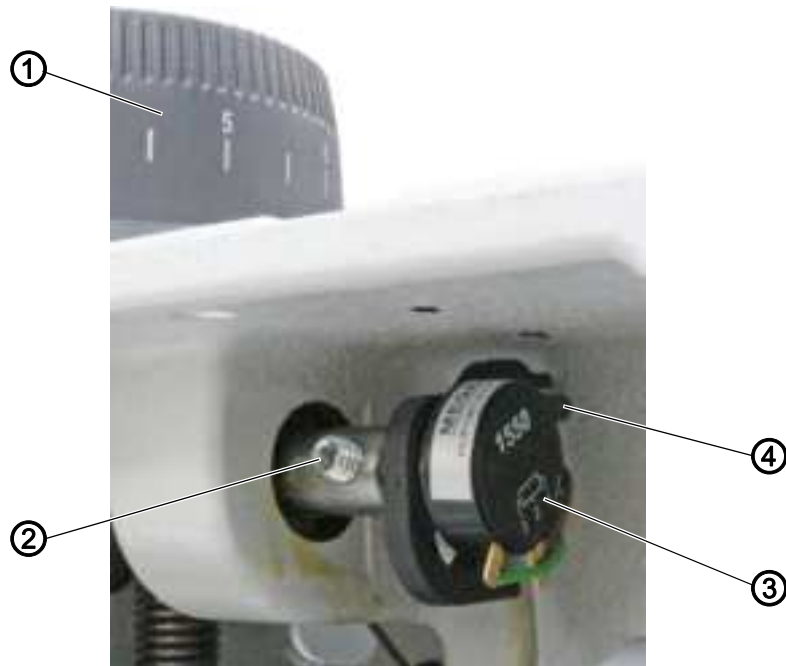

- (1) - Adjusting wheel for sewing foot stroke    (3) - Potentiometer  
(2) - Threaded pin    (4) - Pin



2. Turn the adjusting wheel for the sewing foot stroke (1) to **3**.
3. Loosen the threaded pin (2).
4. Turn the potentiometer axle such that the left display shows **4** in the first instance and the relevant maximum speed next to it.
5. Tighten the threaded pin (2) without the value in the display changing.



**Important**

Ensure that the potentiometer (3) is guided on the pin (4).



6. Press .



**Important**

7. Switch off the machine.
  8. Switch on the machine.
- ↩ Switching off and on will save the adjustment.

## 18 Programming

All settings are performed using the control panel.

### 18.1 OP4000 control panel

Fig. 78: OP4000 control panel





#### 18.1.1 Navigating the control panel

You navigate the control panel by tapping the screen with your fingers. There is no need for an input device. You can open menus by pressing the corresponding button with your finger.

#### 18.1.2 Symbols and tiles

Explanation of recurring symbols:

Icon	Meaning
	The blue letter indicates the active mode. A = Automatic mode M = Manual mode To switch between the modes, press on the symbol.
	Settings Open this menu to access the settings. <ul style="list-style-type: none"> <li>• Parameter settings</li> <li>• User configuration</li> <li>• Service</li> <li>• Data Transfer</li> </ul>
	Value tiles Parameters for which you can/must enter a numerical value. Values can be input by pressing.

Icon	Meaning
	Function tiles (stored) You can activate or deactivate the blue tiles encircled by a white line by pressing. You cannot set any values.
	Multi functional tiles You can activate or deactivate blue tiles encircled by a line and showing a lower green corner by pressing. A long press opens a menu that lets you input values.
	Function tiles (not stored) You cannot enter any values for blue tiles surrounded by a square line. The function assigned to the tile is only active for as long as you press the tile.

## 18.2 Software operating modes

The software of the control panel offers various operating modes:

- **Manual mode** (📖 p. 99)

Manual mode is the simplest operating mode. There are no seam programs and no inputs for individual seam sections.

All programmable sewing parameters can be changed manually during the sewing process.

- **Automatic mode** (📖 p. 99 & 📖 p. 108)













Automatic mode allows you to complete seam programs in 3 different modes:





- Label (4 segments)
- Pocket (6 segments)
- Custom programs P1-P15

All programmable sewing parameters can be set individually for each segment.

### 18.3 Functions of the tiles

Tile	Function	Reference
	Mode <ul style="list-style-type: none"> <li>Select the mode in Automatic mode</li> </ul>	 p. 108
	Program <ul style="list-style-type: none"> <li>Select the program in Automatic mode</li> </ul>	 p. 108
	Bobbin stitch counter <ul style="list-style-type: none"> <li>Indicates the current value</li> </ul>	
	Piece counter <ul style="list-style-type: none"> <li>Indicates the current value</li> </ul>	
	Speed <ul style="list-style-type: none"> <li>Indicates the current speed</li> </ul>	
	Start bartack <ul style="list-style-type: none"> <li>Adjusts the start bartack</li> </ul>	 p. 101
	End bartack <ul style="list-style-type: none"> <li>Adjusts the end bartack</li> </ul>	 p. 102
	Function button <ul style="list-style-type: none"> <li>Activates or deactivates any stored function</li> </ul>	
	Threading mode <ul style="list-style-type: none"> <li>Opens the instructions on how to thread the needle thread</li> <li>Turns on the operation lock of the machine</li> </ul>	
	Bobbin stitch counter <ul style="list-style-type: none"> <li>A long press adjusts the value at which the bobbin is to be changed</li> <li>A short press resets the bobbin stitch counter</li> </ul>	 p. 103
	Piece counter <ul style="list-style-type: none"> <li>Activates or deactivates the piece counter or resets the piece counter</li> </ul>	 p. 104

Tile	Function	Reference
	Speed	<ul style="list-style-type: none"> <li>Defines the maximum permissible speed</li> </ul>  <i>p. 105</i>
	Soft start	<ul style="list-style-type: none"> <li>Activates or deactivates the soft start</li> </ul>  <i>p. 107</i>
	Sewing foot lift after thread trimmer	<ul style="list-style-type: none"> <li>Activates or deactivates the sewing foot lift after thread trimmer</li> <li>The sewing foot lift after thread trimmer lifts the sewing foot after the thread is cut.</li> </ul>
	Sewing foot lift after sewing stop	<ul style="list-style-type: none"> <li>Activates or deactivates the sewing foot lift after sewing stop</li> <li>The sewing foot lift after sewing stop lifts the sewing foot after a sewing stop.</li> </ul>
	Needle position after sewing stop	<ul style="list-style-type: none"> <li>Adjusts the needle position after sewing stop</li> </ul>  <i>p. 106</i>
	Point position	<ul style="list-style-type: none"> <li>Activates or deactivates the Point position function for more effortless needle alignment</li> </ul>  <i>p. 106</i>
	Thread trimmer	<ul style="list-style-type: none"> <li>Activates or deactivates the thread trimmer</li> <li>The thread trimmer cuts the thread at the seam end automatically.</li> </ul>
	Thread clamp	<ul style="list-style-type: none"> <li>Activates or deactivates the thread clamp</li> <li>The thread clamp holds the needle thread firmly to pull it down while sewing on.</li> </ul>
	Backwards	<ul style="list-style-type: none"> <li>Activates or deactivates the Backwards function</li> <li>Sewing backwards is only possible in the automatic mode of the seam program.</li> </ul>

Tile	Function	Reference
	Screen lock <ul style="list-style-type: none"> <li>• Activates the screen lock</li> </ul>	 p. 107
	Light barrier <ul style="list-style-type: none"> <li>• Activates the (optional) Light barrier function</li> <li>• Detects the end of the material and activates end bartack and thread trimmer automatically.</li> </ul>	
	<ul style="list-style-type: none"> <li>• Activates sewing stop at segment switch</li> <li>• To continue with the seam, the pedal must be released in pedal position 0.</li> </ul>	





### 18.3.1 Adjusting the start bartack

The start bartack secures the seam at the seam beginning. If a seam consists of backward stitches only, it is called a single bartack. A seam made up of forward and backward stitches is called a double bartack.

#### Single bartack



To adjust the single bartack:

-  perform a long press.
  - ↳ The interface *Start Backtacking settings* opens.
- Use  and  to adjust stitches *A* and *B* and the number of repeats *n*.
  - $n = 1$  for single bartack
  - $n = 2$  for double bartack
  - $n > 2$  for multi-bartack
- Press  to return to the main screen.
  - ↳ The new values are adopted.







You can begin sewing; press the pedal forward to pedal position +1.

### 18.3.2 Adjusting the end bartack

The end bartack secures the seam at the seam end. If a seam consists of backward stitches only, it is called a single bartack. A seam made up of forward and backward stitches is called a double bartack.



To adjust the single bartack:

1.  perform a long press.
  - ↳ The interface *Start Backtacking settings* opens.
2. Use  and  to adjust stitches *A* and *B* and the number of repeats *n*.
  - $n = 1$  for single bartack
  - $n = 2$  for double bartack
  - $n > 2$  for multi-bartack
3. Press  to return to the main screen.
  - ↳ The new values are adopted.



You can begin sewing; press the pedal forward to pedal position +1. At the end of the seam, press the pedal back to pedal position -2.

### 18.3.3 Adjusting the bobbin stitch counter

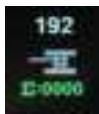

Bobbin supply capacity in stitches. This is a very variable value, which depends on the size of the bobbin and the thickness of the thread.

The bobbin stitch counter outputs a message when the entered number of stitches is reached. The number of stitches should approximately determine when the hook thread is depleted. Thus you avoid having to repeat work processes.

The bobbin stitch counter must be set for every thread type. The value to be set (i.e. 30000) is the product of the default value (reset value) and the number of stitches (factor):

$$3000 \times 10 = 30000$$

You can adjust the factor (1) in the *Operator parameters* (📖 p. 112).

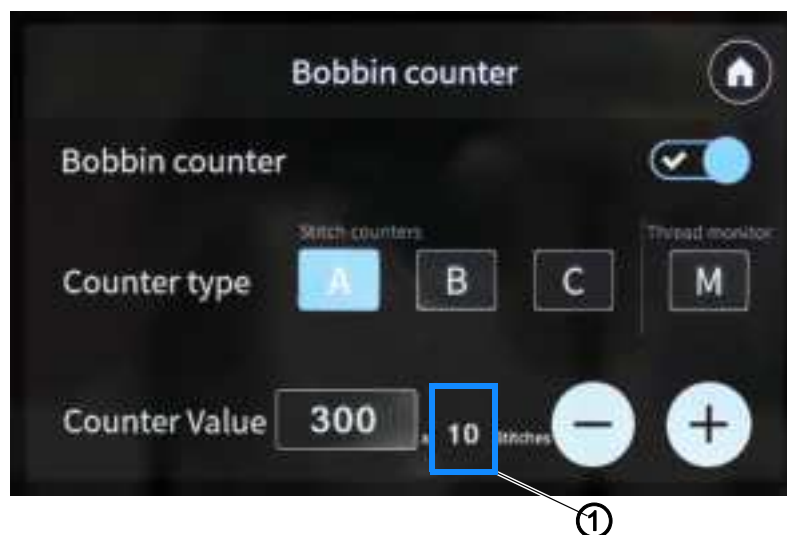

Fig. 79: Bobbin stitch counter



(1) - Factor





To adjust the bobbin stitch counter:

1. Activate *Bobbin counter*.
  2. Select the type:
    - *Thread monitor M*: Activate the optical remaining thread monitor (optional)
    - *A, B and C*: Fully customizable
  3. If necessary, adjust the number of stitches using  and .
  4. Press  to return to the main screen.
- ↪ The new value is indicated in the tile.

### 18.3.4 Piece counter



To reset the piece counter:

1. Perform a long press on the tile .
2. Press  to set the counter value to 0.
3. Press  to return to the main screen.

↳ The new value is indicated in the tile.

OR

4. Perform a short press on the tile .

↳ The counter value is reset.

### 18.3.5 Maximum sewing speed

A reduced speed protects the motor with an ongoing lower speed. Reduced speed is set at the factory as the default.

Fig. 80: Maximum sewing speed

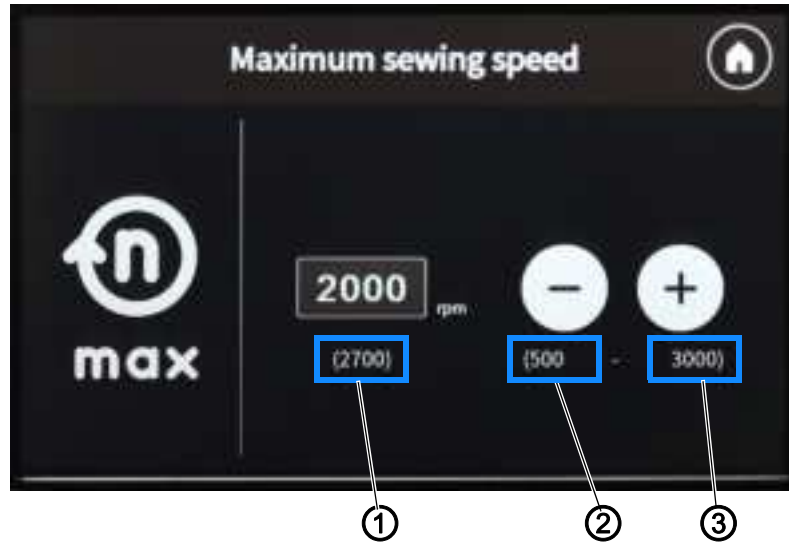





(1) - Default value  
(2) - Minimum value

(3) - Maximum value



To adjust the maximum sewing speed:

1. Press .
  2. Use  and  to adjust the value.
  3. Press  to return to the main screen.
- ↳ The new value is indicated in the tile.



### 18.3.6 Adjusting the needle position after sewing stop

You can determine where the needle is positioned after a sewing stop. There are two options:

- Top dead center (needle position 2)
- Bottom dead center (needle position 1)



To activate the top dead center after a sewing stop:





1. Press .
  - ↳ The round line is white.
  - ↳ The function is activated, i.e. the needle is raised after a sewing stop.
2. If the needle is to be in the bottom dead center after a sewing stop, press  again.

### 18.3.7 Point position

The point position allows you to lower the needle in order to align the sewing material prior to sewing.





To adjust the point position:

1. Perform a long press on the tile .
2. Use  and  to adjust the value.  
Another option is to turn the handwheel to set the desired needle position.
3. Press  to return to the main screen.
  - ↳ The set value is adopted.

### 18.3.8 Activating soft start

The soft start system allows the machine to start at low speed and build up to maximum speed over a defined number of stitches. This function ensures that the sewing process starts reliably.

The default soft start values are found in the  *Parameter list* of the machine and can be adjusted at the technician level ( p. 113).





To activate the soft start:

1. Press .
2. Soft start is activated.

### 18.3.9 Screen lock





To activate the screen lock:

1. Press the tile .
-  The screen is locked to prevent inadvertent touches.



To deactivate the screen lock:

1. Perform a long press on the tile .
-  The screen lock is canceled.

### 18.4 Automatic mode



To sew in Automatic mode:

1. Press  to select a mode.

↳ The selection menu opens:

Fig. 81: Automatic mode (1)

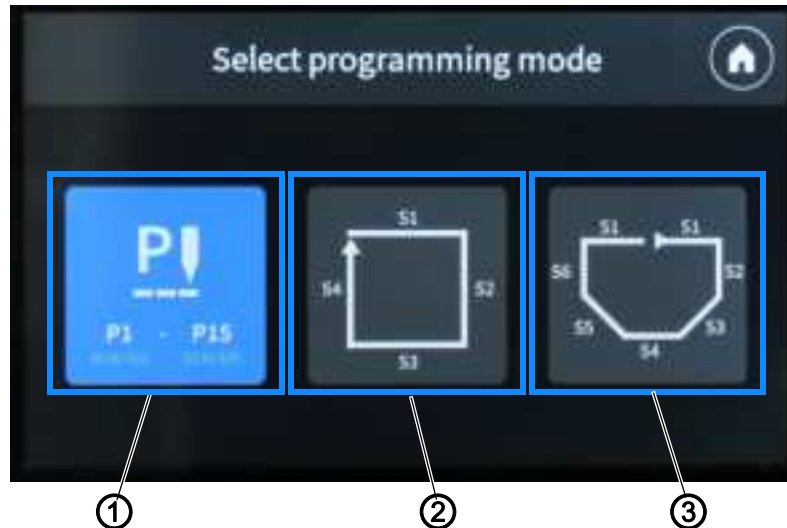

- (1) - Fully customizable programs (P1-P15) with up to 25 segments
- (2) - Preset program with 4 segments
- (3) - Preset program with 6 segments

2. If you selected Fully customizable programs (P1 - P15) with up to 25 segments (1), press  to select one of the programs:

Fig. 82: Automatic mode (2)



Fig. 83: Automatic mode (3)



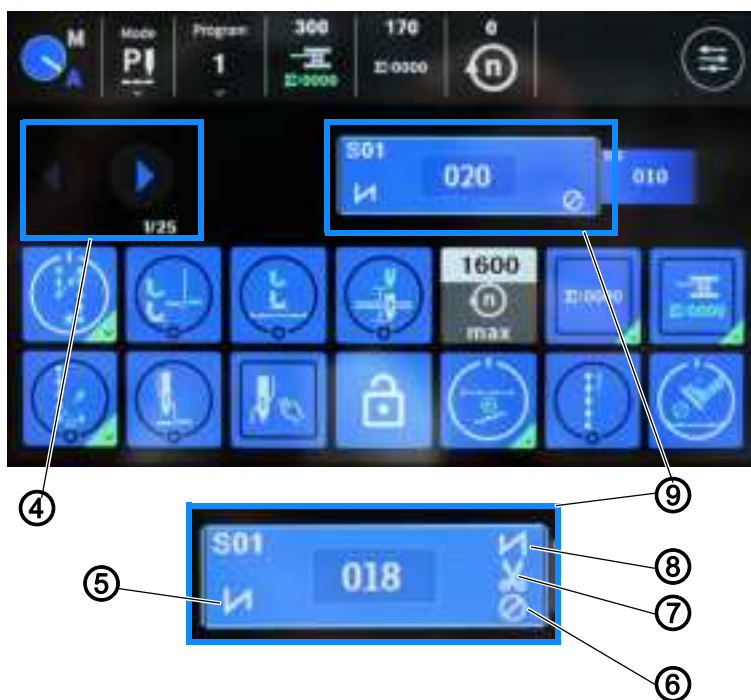

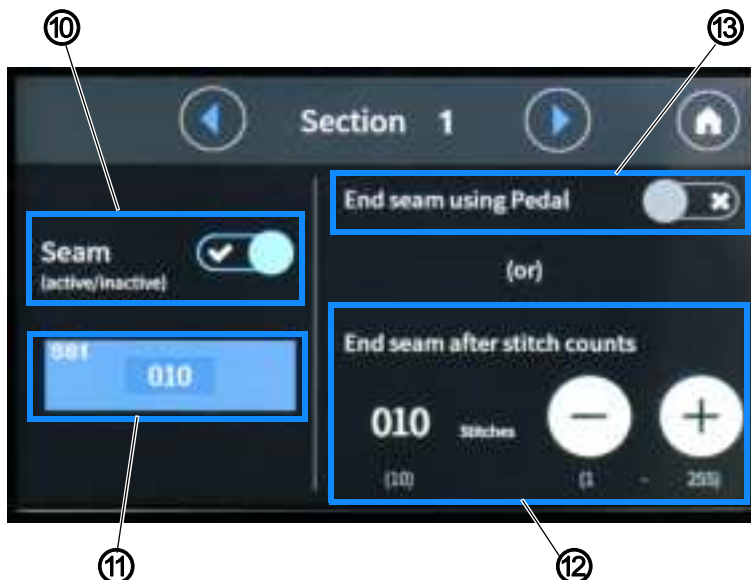

- (4) - Arrow keys
- (5) - Start bartack active
- (6) - Sewing stop at segment switch active
- (7) - Thread trimmer active
- (8) - End bartack active
- (9) - Active segment display

3. Use the arrow keys (4) to select the active segment.
4. Press the Active segment display (9).

Fig. 84: Automatic mode (4)



- (10) - Activate/deactivate segment
- (11) - Active segment display
- (12) - Segment switch after number of stitches
- (13) - Segment switch by pedal

5. Activate segment switch by pedal (13).  
Or:  
Adjust the number of stitches for Segment switch after number of stitches (12) using  and .
6. Press  to return to Automatic mode.
  - ↳ The setting for the active segment is adopted.
7. Adjust the settings using tiles ( p. 99) and buttons ( Operating Instructions).
- ↳ All settings only apply to the active segment.
8. Start sewing.



### Information

If you activated Segment switch after number of stitches (12), but do not want the machine to continue automatically with the next segment, activate the tile .

This setting is without effect in the last segment. The seam is finished automatically with end bartack and thread trimmer after the set number of stitches.



To switch segments based on number of stitches and by pedal:

1. To start sewing, press the pedal forwards to pedal position +1.
  - ↳ The machine keeps sewing until the specified number of stitches has been reached.
2. Release the pedal in pedal position 0.
  - ↳ The switch to the next segment is carried out.
3. Align the sewing material if necessary.

To start sewing in the next segment, press the pedal forwards to pedal position +1.











## 18.5 Settings



To open the *Settings*:

1. Press the symbol .

↳ The *Settings* menu opens:

Menu item	Explanation
 Parameter settings	<ul style="list-style-type: none"> <li>• Operator parameters ( p. 112)</li> <li>• Technician parameters ( p. 113)</li> <li>• Developer parameters (developer access only)</li> </ul>
 User configuration	<ul style="list-style-type: none"> <li>• Language</li> <li>• Display brightness</li> <li>• Display volume</li> <li>• Panel version</li> </ul>
 Service	<ul style="list-style-type: none"> <li>• Multi test ( p. 115)</li> <li>• Reset programs ( p. 118)</li> <li>• Factory reset ( p. 119)</li> </ul>
 Data Transfer	<ul style="list-style-type: none"> <li>• Export ( p. 120)</li> <li>• Import ( p. 120)</li> </ul>

### 18.5.1 Parameter settings

#### Operator parameters



To set the parameters on the operator level:

1. Open *Settings* > *Parameter settings* > *Operator parameters*.

Fig. 85: Operator parameters









2. Use the arrows  and  to set the parameters.



#### Information

All parameter settings are found in the  *Parameter list* of the machine. The parameters on the operator level are marked with *o* at the front.

3. Adjust the settings of values using the  and  buttons.
  4. Activate/deactivate parameters by pressing the button . The selected status (active/inactive) is highlighted with a color.
  5. Press  to return to the *Parameter settings* or press  to return to the main screen.
-  The new setting is adopted.

### Technician parameters





To set the parameters on the technician level:

1. Open *Settings* > *Parameter settings* > *Technician Parameters*.

Fig. 86: Technician parameters(1)



2. Use the arrows  and  to enter the 4-digit password 2548.
3. Press *confirm* to confirm the password you entered.







### Information

The password must be re-entered after every restart of the machine.

Fig. 87: Technician parameters (2)





4. Use the arrows  and  to set the desired parameter.
5. Adjust the settings of values using the  and  buttons.
6. Activate/deactivate parameters by pressing the button . The selected status (active/inactive) is highlighted with a color.



### Information

All parameter settings are found in the  *Parameter list* of the machine. The parameters on the technician level are marked with  $t$  at the front.

7. Press  to return to the *Parameter settings* or press  to return to the main screen.
-  The new setting is adopted.

## 18.5.2 Service

### Multi test

This parameter makes it possible to test whether, for example, magnets, drives, and inputs or outputs are functioning correctly. A list of the necessary allocations can be found in the [Parameter list](#) of the machine.

Fig. 88: Multi test



### Opening Test analog

The *Test analog* button is used to list the hardware tests that can be carried out in analog fashion. For more detailed descriptions of the functions, refer to the [Parameter list](#) found at technician level *t 51 12*.

## Opening Test inputs

Fig. 89: Opening Test inputs

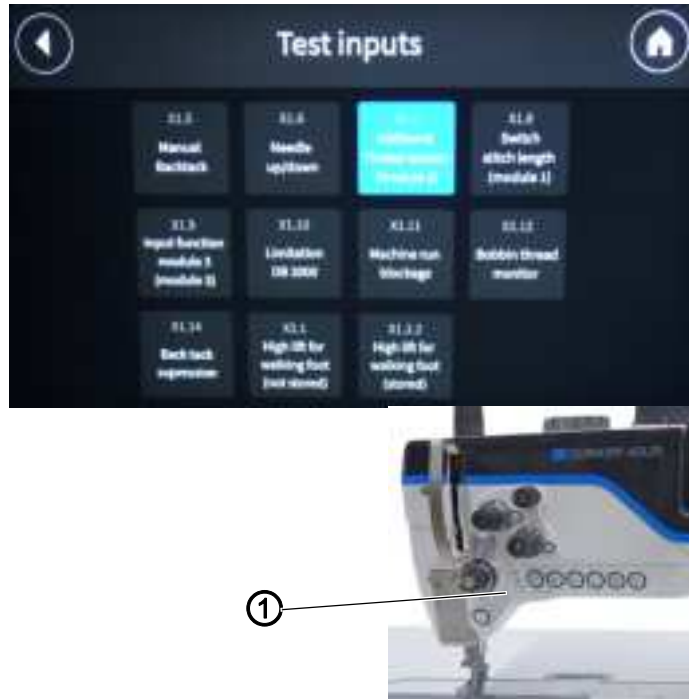

(1) - Push buttons





To check the inputs:

1. Press *Settings* > *Service* > *Multi test* > *Test inputs*.
  2. Activate the inputs by pressing the push buttons (1).
- ↳ The display on the control panel automatically switches to the corresponding input that was activated with a press of the push buttons. The input is highlighted in color on the control panel.



### Information

The possible inputs of the machine are found and described in the [Parameter list](#) at technician level *t 51 12*.

3. Press  to return to the menu item *Service* or  
press  to return to the main screen.

## Opening Test outputs

Fig. 90: Opening Test outputs

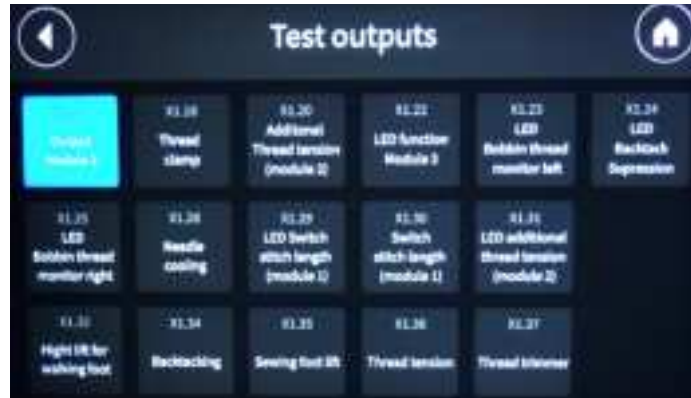



To test the outputs:

1. Press *Settings* > *Service* > *Multi test* > *Test outputs*.
  2. Press the output on the control panel.
- ↳ The selected output is highlighted in color on the control panel, and the test is performed accordingly by the machine.



### Information

All possible outputs of the machine are found and described in the  *Parameter list* at technician level *t 51 12*.

3. Press  to return to the menu item *Service* or press  to return to the main screen.

## Resetting programs

### NOTICE

#### Property damage may occur!

Data and settings of the machine may be irretrievably lost.

Consider BEFORE the reset whether you really wish to delete the data.



To reset all programs:

1. Open *Settings* > *Service* > *Reset programs*.

Fig. 91: Reset programs

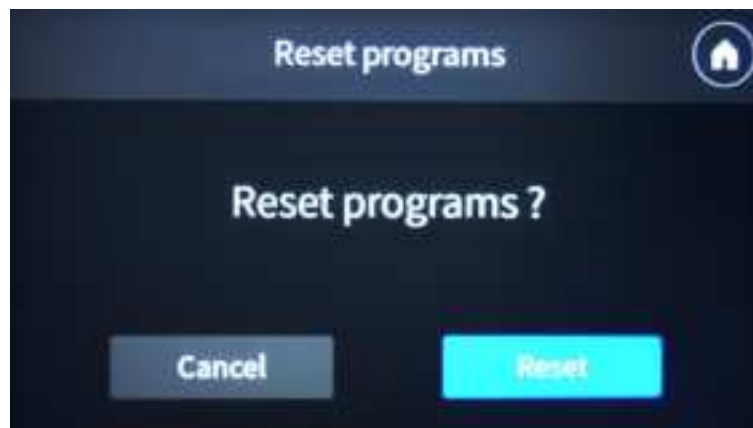

2. Select *Reset* to initialize the programs.
3. Press *Cancel* to return to the menu item *Service* or press  to return to the main screen.

## Factory reset

### NOTICE

#### Property damage may occur!

Data and settings of the machine may be irretrievably lost.

Consider BEFORE the reset whether you really wish to delete the data.



To restore the factory settings:

1. Open *Settings* > *Service* > *Factory reset*.

Fig. 92: Factory reset



2. Select *Reset* to initialize the machine to the factory settings.
3. Press *Cancel* to return to the menu item *Service* or press  to return to the main screen.

### 18.5.3 Data transfer

#### Exporting data



To export data:

1. Connect the USB key at the control panel
2. Open *Settings > Data transfer > Export*.
3. Press the desired export option:

Menu item	Explanation
<i>Export parameters to dongle</i>	Export parameters to the USB key
<i>Export parameters to backup area</i>	Export parameters as a backup
<i>Export programs to dongle</i>	Export programs to the USB key

4. Confirm selection.
- ↳ The data has been exported.

#### Importing data



To import data:

1. Connect the USB key at the control panel
2. Open *Settings > Data transfer > Import*.
3. Press the desired import option:

Menu item	Explanation
<i>Import parameters from dongle</i>	Import parameters from the USB key
<i>Import parameters from backup area</i>	Import parameters from the backup
<i>Import programs from dongle</i>	Import programs from the USB key

4. Confirm selection.
- ↳ The data has been imported.

## 19 Maintenance

This chapter describes maintenance work that needs to be carried out on a regular basis to extend the service life of the machine and achieve the desired seam quality.

Advanced maintenance work may only be carried out by qualified specialists ( *Service Instructions*).

### WARNING



#### Risk of injury from sharp parts!

Punctures and cutting possible.

Prior to any maintenance work, switch off the machine or set the machine to threading mode.

### WARNING



#### Risk of injury from moving parts!

Crushing possible.

Prior to any maintenance work, switch off the machine or set the machine to threading mode.

### Maintenance intervals

Work to be carried out	Operating hours			
	8	40	160	500
<b>Machine head</b>				
Remove fluff, sewing dust and thread residues	●			
Cleaning the motor fan mesh			●	
Check the oil level		●		
<b>Pneumatic system</b>				
Check the water level in the pressure regulator	●			
Check the filter element in the maintenance unit				●
Check the tightness of the system				●

## 19.1 Cleaning

### WARNING



#### **Risk of injury from flying particles!**

Flying particles can enter the eyes, causing injury.

Wear safety goggles.

Hold the compressed air gun so that the particles do not fly close to people.

Make sure no particles fly into the oil pan.

### NOTICE

#### **Property damage from soiling!**

Sewing dust and thread residues can impair the operation of the machine.

Clean the machine as described.

### NOTICE

#### **Property damage from solvent-based cleaners!**

Solvent-based cleaners will damage paintwork.

Use only solvent-free substances for cleaning.

### 19.1.1 Areas requiring special cleaning

Sewing dust and thread residues should be removed after every 8 operating hours using a compressed air gun or a brush. If very fluffy sewing material is being sewn, the machine must be cleaned even more frequently.

Fig. 93: Areas requiring special cleaning

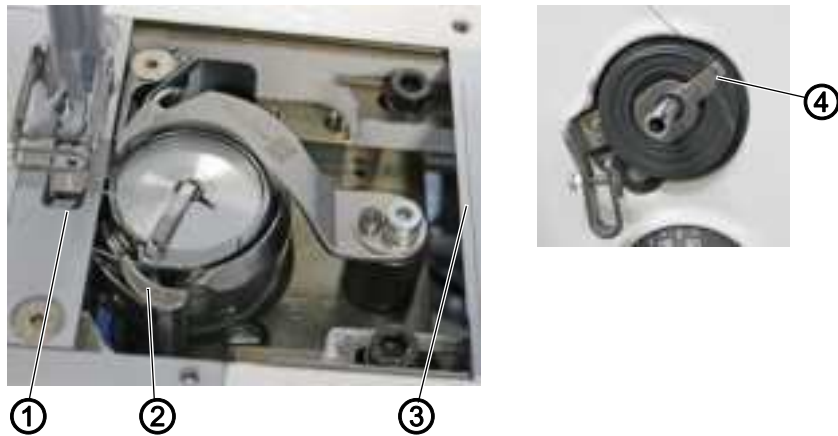

(1) - Area around the needle  
(2) - Hook

(3) - Area under the throat plate  
(4) - Knife on the winder

**Check and clean daily:**

- Knife on the winder (4)
- Area under the throat plate (3)
- Hook (2)
- Area around the needle (1)



To clean areas that are susceptible to soiling:

1. Switch off the machine.
2. Remove any lint and thread remnants using a compressed air gun or a brush.

### 19.1.2 Cleaning the motor fan mesh

The motor fan mesh must be cleaned every 100 - 200 operating hours using a compressed air gun. If very fluffy sewing material is being sewn, the motor fan mesh must be cleaned even more frequently.

Fig. 94: Cleaning the motor fan mesh (1)



(1) - Motor



To clean the motor fan mesh:

1. Switch off the machine.
2. Remove the arm cover.
3. Remove any lint and thread remnants using a brush.

Fig. 95: Cleaning the motor fan mesh (2)



(2) - Ventilation slots

4. Clean the ventilation slots (2) in the motor cover.

## 19.2 Lubricating

### CAUTION



#### Risk of injury from contact with oil!

Oil can cause a rash if it comes into contact with skin.

Avoid skin contact with oil.  
If oil has come into contact with your skin, wash the affected areas thoroughly.

### NOTICE

#### Property damage from incorrect oil!

Incorrect oil types can result in damage to the machine.

Only use oil that complies with the data in the instructions.

### ACHTUNG/CAUTION/UPOZORNĚNÍ



#### Risk of environmental damage from oil!

Oil is a pollutant and must not enter the sewage system or the soil.

Carefully collect up used oil.  
Dispose of used oil and oily machine parts in accordance with national regulations.

The machine is equipped with a central oil-wick lubrication system.  
The bearings are supplied from the oil reservoir.

For topping off the oil reservoir, use only lubricating oil **DA 10** or oil of equivalent quality with the following specifications:

- Viscosity at 40 °C: 10 mm<sup>2</sup>/s
- Flash point: 150°C

You can order the lubricating oil from our sales offices using the following part numbers.

Container	Part no.
250 ml	9047 000011
1 l	9047 000012
2 l	9047 000013
5 l	9047 000014

### 19.2.1 Check the oil level

Fig. 96: Check the oil level

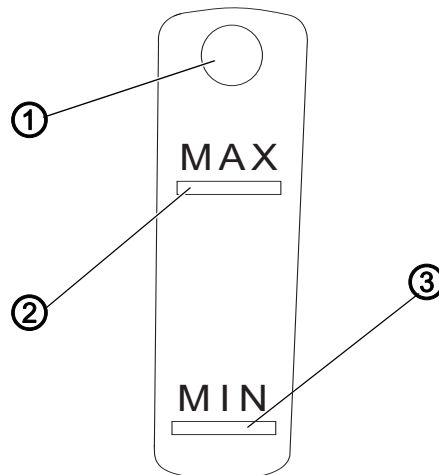

(1) - Refill opening

(2) - Maximum level marking

(3) - Minimum level marking



To check the oil level:

1. Check the oil level indicator every day.
  - The oil level must be between the minimum level marking (3) and the maximum level marking (2).

#### Topping off the oil



To top off the oil:

1. Pour in oil through the refill opening (1).
- ↳ Add oil up to but not past the maximum level marking (2).

### 19.2.2 Checking the hook lubrication

The approved oil quantity for hook lubrication is a factory specification.



#### Proper setting

1. Hold a piece of blotting paper next to the hook.
2. Allow the machine to run without thread and sewing material for 10 seconds with the sewing feet lifted and at a high speed.
- ↳ The blotting paper will show a thin strip of oil when sewing is complete.

Fig. 97: Checking the hook lubrication



(1) - Screw



To lubricate the hook:

1. Turn the screw (1):
  - counterclockwise: more oil is released
  - clockwise: less oil is released



### Important

The released amount of oil does not change until the operating time has run a few minutes. Sew for several minutes before you check the setting again.

## 19.3 Servicing the pneumatic system

### 19.3.1 Adjusting the operating pressure

#### NOTICE

#### Property damage from incorrect adjustment!

Incorrect operating pressure can result in damage to the machine.

Ensure that the machine is only used when the operating pressure is set correctly.



#### Proper setting

Refer to the **Technical Data** ( p. 139) chapter for the permissible operating pressure. The operating pressure cannot deviate by more than  $\pm 0.5$  bar.

Check the operating pressure on a daily basis.

Fig. 98: Adjusting the operating pressure

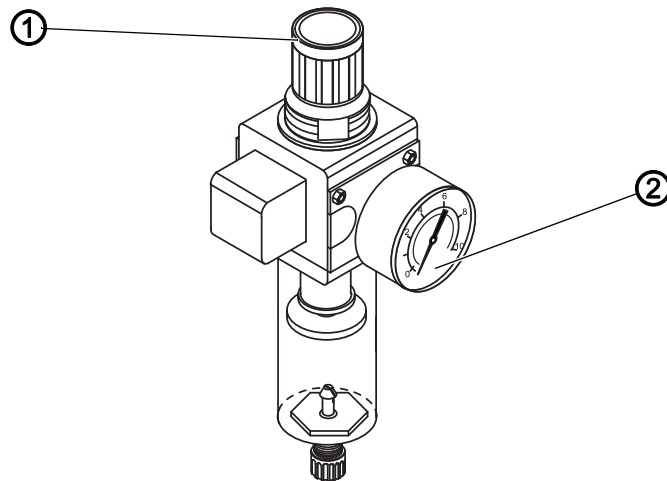

(1) - Pressure regulator

(2) - Pressure gage



To adjust the operating pressure:

1. Pull the pressure regulator (1) up.
2. Turn the pressure regulator until the pressure gage (2) indicates the proper setting:
  - Increase pressure = turn clockwise
  - Reduce pressure = turn counterclockwise
3. Push the pressure regulator (1) down.

### 19.3.2 Draining the water condensation

#### NOTICE

##### Property damage from excess water!

Excess water can cause damage to the machine.

Drain water as required.

Water condensation accumulates in the water separator (2) of the pressure regulator.



##### Proper setting

Water condensation must not rise up to the level of the filter element (1).

Check the water level in the water separator (2) on a daily basis.

Fig. 99: Draining the water condensation

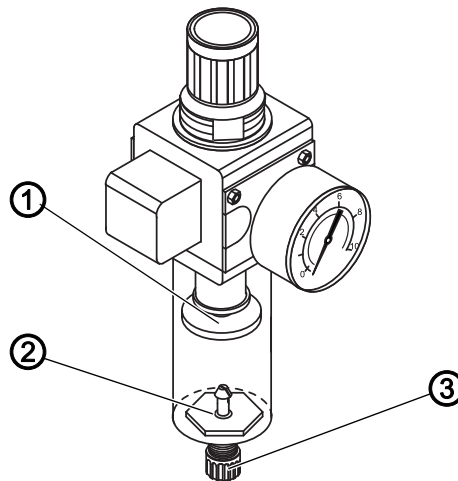

(1) - Filter element

(2) - Water separator

(3) - Drain screw



To drain water condensation:

1. Disconnect the machine from the compressed air supply.
2. Place a collection tray under the drain screw (3).
3. Loosen the drain screw (3) completely.
4. Allow water to drain into the collection tray.
5. Tighten the drain screw (3).
6. Connect the machine to the compressed air supply.

### 19.3.3 Cleaning the filter element

#### NOTICE

**Damage to the paintwork from solvent-based cleaners!**

Solvent-based cleaners damage the filter.

Use only solvent-free substances for washing out the filter tray.

Fig. 100: Cleaning the filter element

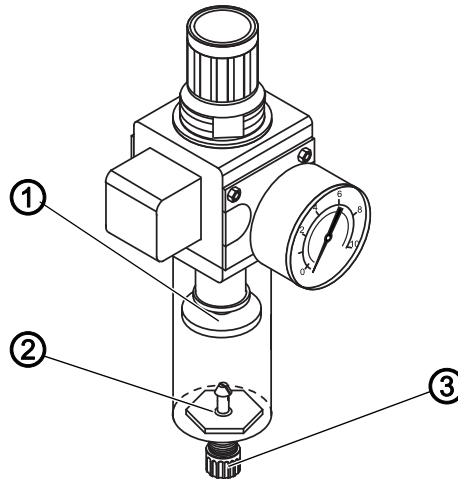

(1) - Filter element  
(2) - Water separator

(3) - Drain screw



To clean the filter element:

1. Disconnect the machine from the compressed air supply.
2. Drain the water condensation ( p. 129).
3. Loosen the water separator (2).
4. Unscrew the filter element (1).
5. Blow out the filter element (1) using a compressed air gun.
6. Wash out the filter tray using benzine.
7. Tighten the filter element (1).
8. Tighten the water separator (2).
9. Tighten the drain screw (3).
10. Connect the machine to the compressed air supply.

### 19.4 Parts list

A parts list can be ordered from Dürkopp Adler. Or visit our website for further information at:

[www.duerkopp-adler.com](http://www.duerkopp-adler.com)





## 20 Decommissioning

### WARNING



#### **Risk of injury from a lack of care!**

Serious injuries may occur.

ONLY clean the machine when it is switched off.  
Allow ONLY trained personnel to disconnect  
the machine.

### CAUTION



#### **Risk of injury from contact with oil!**

Oil can cause a rash if it comes into contact with  
skin.

Avoid skin contact with oil.  
If oil has come into contact with your skin, wash  
the affected areas thoroughly.



To decommission the machine:

1. Switch off the machine.
2. Unplug the power plug.
3. If applicable, disconnect the machine from the compressed air supply.
4. Remove residual oil from the oil pan using a cloth.
5. Cover the control panel to protect it from soiling.
6. Cover the control to protect it from soiling.
7. Cover the entire machine if possible to protect it from contamination and damage.



## 21 Disposal

### CAUTION



#### **Risk of environmental damage from improper disposal!**

Improper disposal of the machine can result in serious environmental damage.

ALWAYS comply with the national regulations regarding disposal.



The machine must not be disposed of in the normal household waste.

The machine must be disposed of in a suitable manner in accordance with all applicable national regulations.

When disposing of the machine, be aware that it consists of a range of different materials (steel, plastic, electronic components, etc.). Follow the national regulations when disposing these materials.



## 22 Troubleshooting

### 22.1 Customer Service

Contact for repairs and issues with the machine:

#### Dürkopp Adler GmbH

Potsdamer Str. 190  
33719 Bielefeld, Germany

Tel. +49 (0) 180 5 383 756

Fax +49 (0) 521 925 2594

Email: [service@duerkopp-adler.com](mailto:service@duerkopp-adler.com)

Internet: [www.duerkopp-adler.com](http://www.duerkopp-adler.com)



### 22.2 Errors in sewing process

Error	Possible causes	Corrective
Unthreading at seam beginning	Needle thread tension is too firm	Check needle thread tension
Thread breaking	Needle thread and hook thread have not been threaded correctly	Check threading path
	Needle is bent or sharp-edged	Replace needle
	Needle is not inserted correctly into the needle bar	Insert the needle correctly into the needle bar
	The thread used is unsuitable	Use recommended thread
	Thread tensions are too tight for the thread used	Check thread tensions
	Thread-guiding parts, such as thread tube, thread guide or thread take-up disk, are sharp-edged	Check threading path
	Throat plate, hook or spread have been damaged by the needle	Have parts reworked by qualified specialists

<b>Error</b>	<b>Possible causes</b>	<b>Corrective</b>
Skip stitches	Needle thread and hook thread have not been threaded correctly	Check threading path
	Needle is blunt or bent	Replace the needle
	Needle is not inserted correctly into the needle bar	Insert the needle correctly into the needle bar
	The needle thickness used is unsuitable	Use recommended needle thickness
	The reel stand is assembled incorrectly	Check the assembly of the reel stand
	Thread tensions are too tight	Check thread tensions
	Throat plate, hook or spread have been damaged by the needle	Have parts reworked by qualified specialists
Loose stitches	Thread tensions are not adjusted to the sewing material, the sewing material thickness or the thread used	Check thread tensions
	Needle thread and hook thread have not been threaded correctly	Check threading path
Needle breakage	Needle thickness is unsuitable for the sewing material or the thread	Use recommended needle thickness

## 23 Technical data

### 23.1 Data and characteristic values

Technical data	Unit	G767-180142	G767-180145	G767-180342	G767-280142	G767-2803421
Machine type		Double lockstitch 301				
Hook type		Vertical hook, XXL				
Number of needles		1	1	1	2	2
Needle system		134-35				
Needle strength	[Nm]	90-180				
Thread strength	[Nm]					
Stitch length	[mm]	9/9				
Speed maximum	[min <sup>-1</sup> ]	3000				
Speed on delivery	[min <sup>-1</sup> ]	3000				
Mains voltage	[V]	230				
Mains frequency	[Hz]	50/60				
Operating pressure	[bar]	6				
Length	[mm]	675				
Width	[mm]	255				
Height	[mm]	445				
Weight	[kg]	59			60	
Power input	[kVA]	0.646				

### 23.2 Requirements for fault-free operation

Compressed air quality must conform to ISO 8573-1: 2010 [7:4:4].





Fig. 102: Wiring diagram (2)

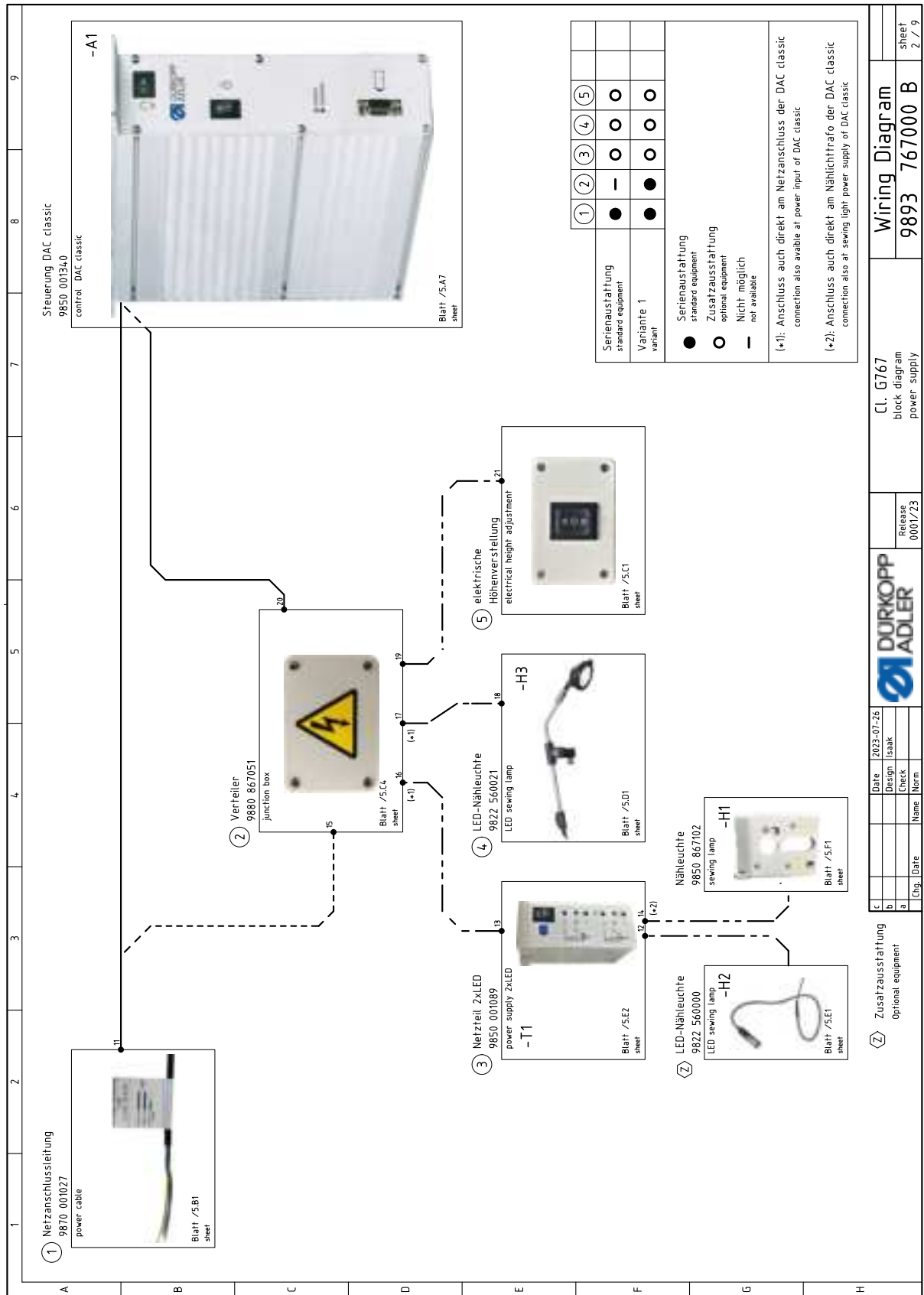

Serienausstattung standard equipment	1	2	3	4	5
Variante 1 variant	●	—	○	○	○
Serienausstattung standard equipment	●	○	○	○	○
Zusatzausstattung optional equipment	○	○	○	○	○
Nicht möglich not available	—	—	—	—	—

(\*)1: Anschluss auch direkt am Netzanschluss der DAC classic  
connection also available at power input of DAC classic

(\*)2: Anschluss auch direkt am Nählichtrafo der DAC classic  
connection also at sewing light power supply of DAC classic

Cl. G767 block diagram power supply		Release 0001/23		Date: 2023-07-26	
DÜRKOPP ADLER		Design: Isak		Check: _____	
Wiring Diagram 9893 767000 B		Name: _____		Norm: _____	
Sheet 2 / 9		Date: _____		Date: _____	
Zusatzausstattung Optional equipment		Date: _____		Date: _____	

Fig. 103: Wiring diagram (3)

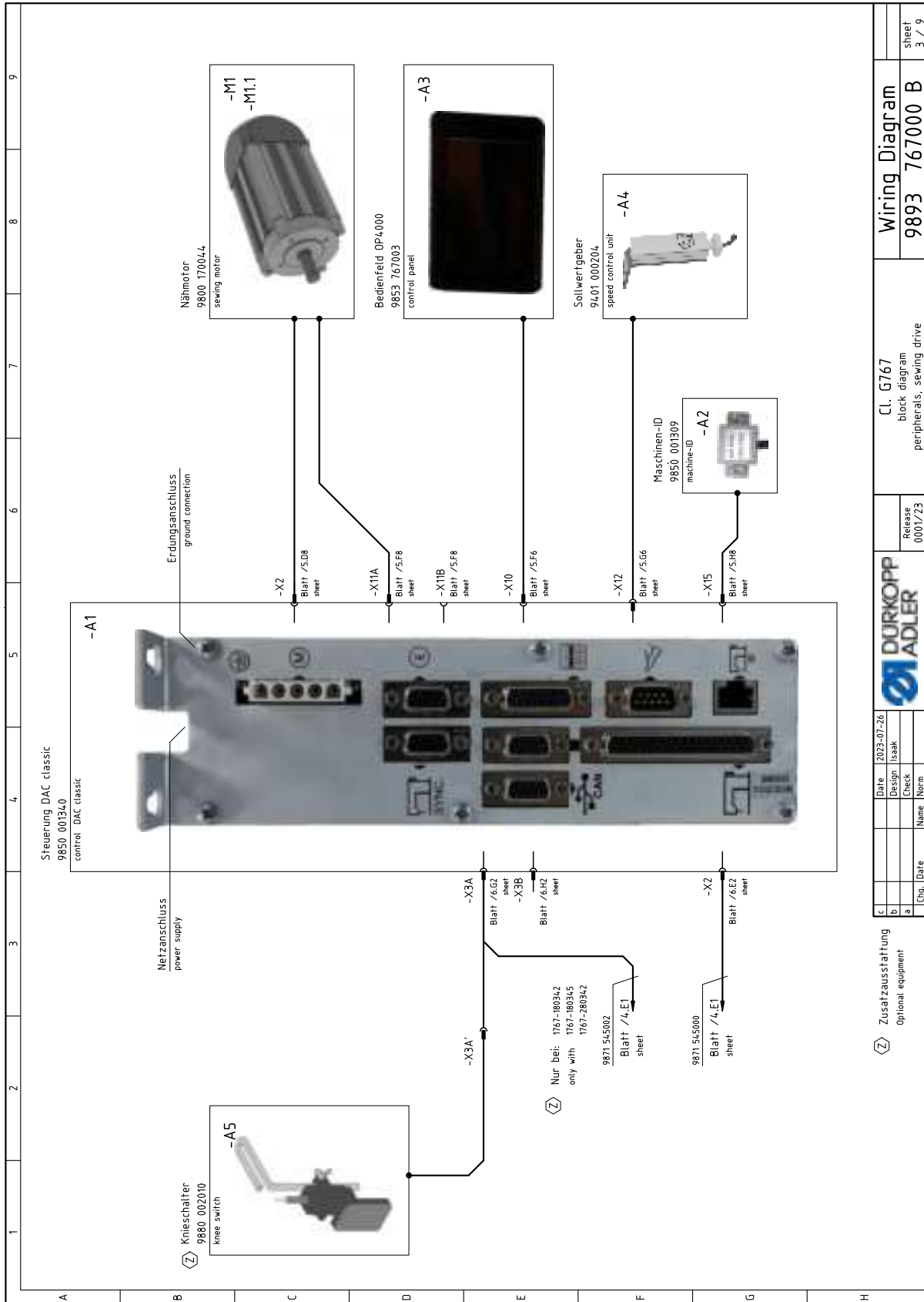

Date		2023-07-26			Cl. G767 block diagram peripherals, sewing drive	Wiring Diagram 9893 767000 B	sheet 3 / 9
Design		Isak					
Check							
Name		Norm		Releases		0001/23	
Zusatzausstattung		Optional equipment					

Fig. 104: Wiring diagram (4)

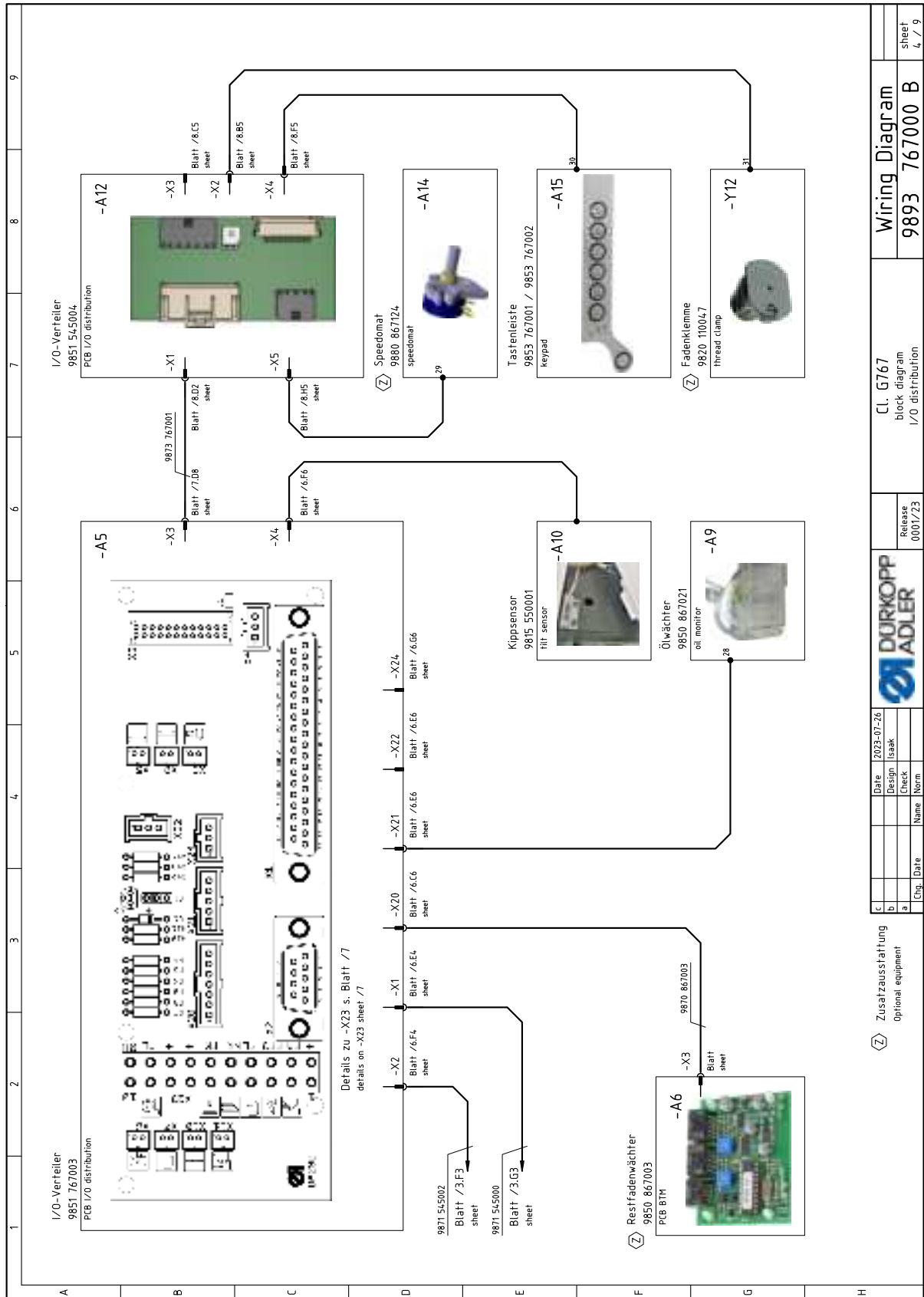

Date: 2023-07-26		Sheet: 4 / 9	
Design: Isak		Wiring Diagram	
Check: Norm		9893 767000 B	
Name: Norm		Cl. G767	
Chg. Date: Norm		block diagram	
Chg. Date: Norm		I/O distribution	
Chg. Date: Norm		Release: 0001/23	
Chg. Date: Norm		Zusatzausstattung	
Chg. Date: Norm		Optional equipment	







Fig. 108: Wiring diagram (8)

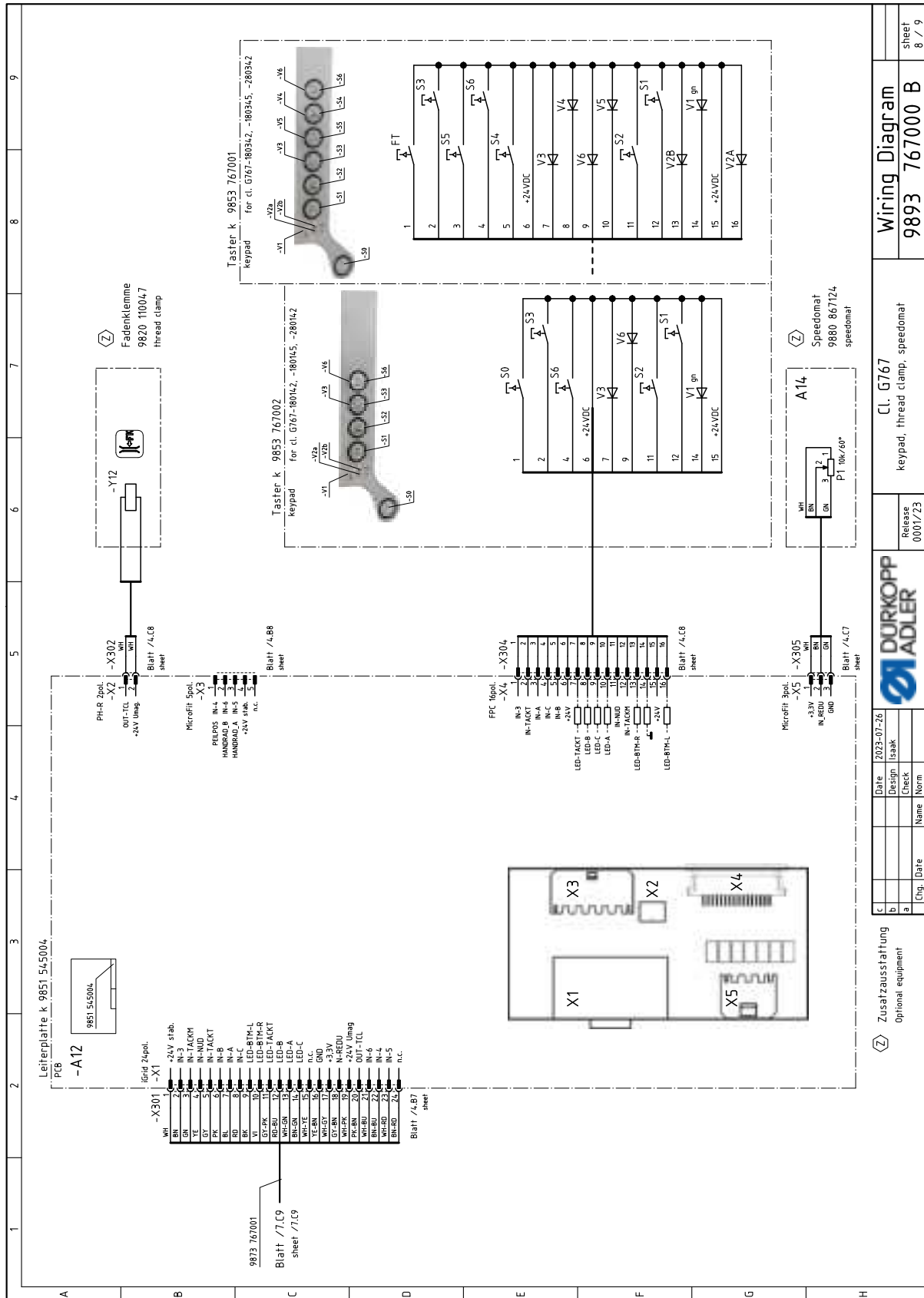

Date: 2023-07-26		Design: /s:abk		Name: /		Norm: /	
Chg: /		Date: /		Name: /		Norm: /	
C		b		a		b	
Zusatzausstattung Optional equipment		Cl. G767 keypad, thread clamp, speedomat		Wiring Diagram 9893 767000 B		sheet 8 / 9	

Fig. 109: Wiring diagram (9)

1	2	3	4	5	6	7	8	9	
A	Bezeichnung denomination	Teilmr.-Baugruppe partno. assembly	Teilmr.-Schaltplan partno. schematic						
	-A1	Steuerung DAC classic control DAC classic	9850 001340	9850 001340					
	-A2	Maschinen-ID machine-ID	9850 001309	9850 001309					
B	-A3	Bedienfeld OP4000 control panel OP4000	9853 767003						
	-A4	Sollwertgeber speed control unit	94.01 000204						
	-A5	Verteiler-Platine distribution board	9851 767003	9851 767003					
C	Ⓢ -A6	Restfadenwächter PCB bobbin thread monitor	9850 867003	9850 867003					
	Ⓢ -A7	Restfadenwächter rechts bobbin thread monitor right	9815 925002						
	Ⓢ -A8	Restfadenwächter links bobbin thread monitor left	9815 925002						
	-A9	Ölüberwachung oil monitor	9850 867021						
D	-A10	Kippsensor tilt sensor	9815 550001						
	Ⓢ -A11	Knieschalter knee switch	9880 002005						
	-A12	Verteiler-Platine distribution board	9851 545004	9851 545004					
E	Ⓢ -A13	Tasteneinleiste keypad	9853 767001 9853 767002						
	Ⓢ -A14	Speedomat speedomat	9880 867124						
F	Bezeichnung denomination	Teilmr.-Baugruppe partno. assembly							
	-H1	Nähleuchte integriert sewing lamp	3767 490034						
	Ⓢ -H2	LED-Nähleuchte LED sewing lamp	9822 560000						
G	Ⓢ -H3	LED-Nähleuchte LED sewing lamp	9822 560021						
H	Ⓢ Zusatzausstattung Optional equipment					Cl. G767 partlist		Wiring Diagram 9893 767000 B	
				Release 0001/23				Sheet 9 / 9	

## 24.2 Pneumatic diagram

Fig. 110: Pneumatic diagram

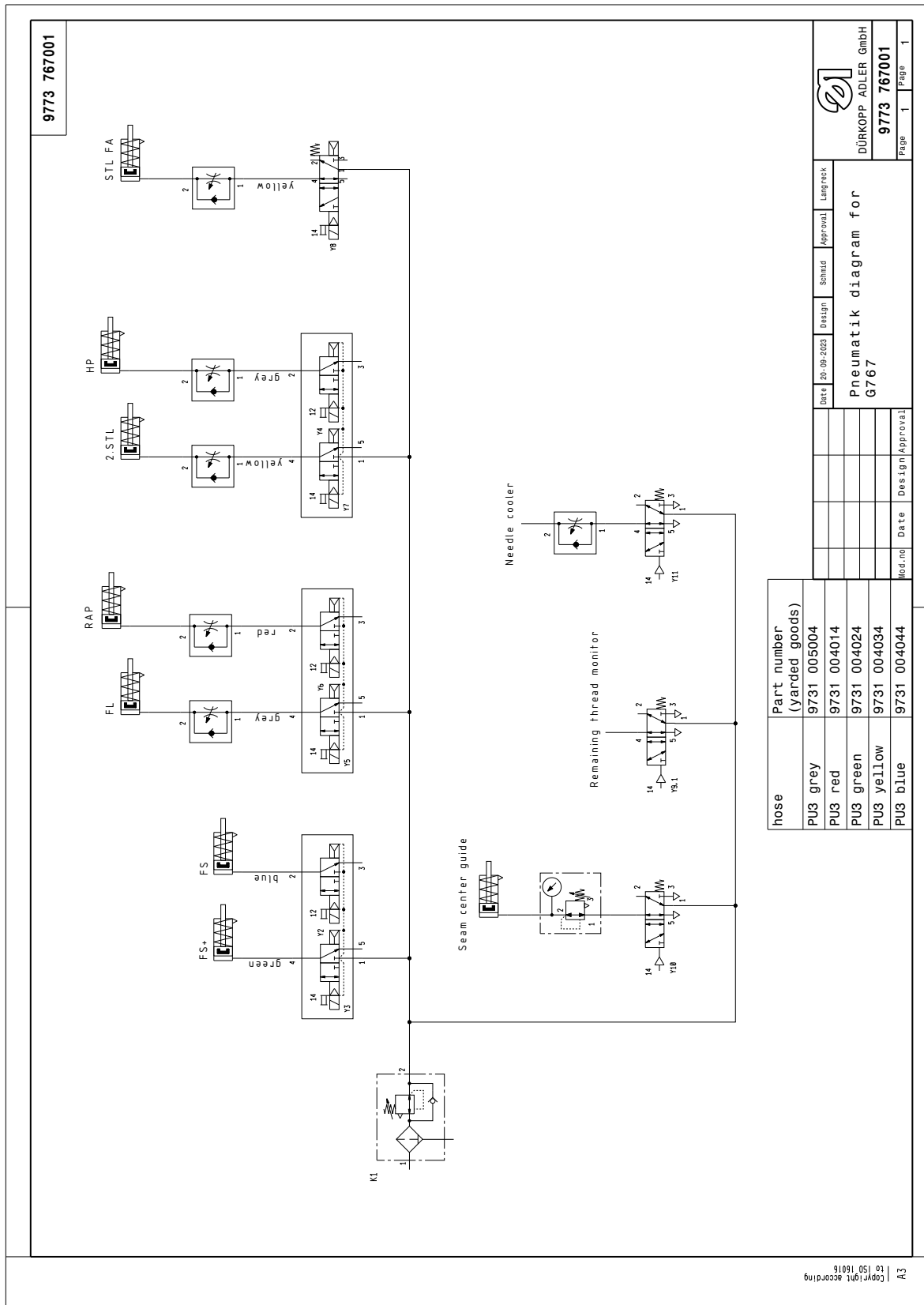





DÜRKOPP ADLER GmbH  
Potsdamer Str. 190  
33719 Bielefeld  
Germany  
Phone: +49 (0) 521 925 00  
Email: [service@duerkopp-adler.com](mailto:service@duerkopp-adler.com)  
[www.duerkopp-adler.com](http://www.duerkopp-adler.com)