

JUKI®

**Direct-drive, High-speed, Lockstitch Machine
with an Automatic Thread Trimmer**

ダイレクトドライブ高速本縫自動糸切りミシン

DDL-9000B

PARTS LIST

40089326

No.1532-01

HOW TO MAKE USE OF THIS PARTS LIST

1.Explanation of codes

1)"*"mark.....means this part is changed from the previous parts book.

As to the details of the change, refer to "List for information of change".

2)"#01".....refer to "Note" explanation at bottom of page.

2.Codes on the "Qty" column

- Each numeral indicates the number of parts required.
- "0.1" and "2.5" indicate the length (in meters) of the respective parts.

3.Parentheses mean that the corresponding part is a subpart that constructs an assembly part.

4.Dotted lines on the Figures indicate assembly parts.

5.As to the parts with marks of "☆"(consumable parts) and "◎"(optional parts)on the respective parts, it is recommended to prepare spares.

6.List page GG, BB and signs indicate the destination.

Sign	Place of destination
GG	China
BB	Europe
EE	Japan
AA	excludes China, Europe and Japan

パーツリストご利用に際して

1."注記"欄の記号説明

1)"*"印.....前回のパーツブックに比較して今回変更された部品を意味します。

変更内容は"変更情報リスト"を参照してください。

2)"#01".....ページ下の"注記"の説明を参照してください。

2.数量欄の数字は、個数を表し、0.1、2.5等の数値は、長さ(単位メートル)を表します。

3.数量欄の()は、組部品を構成している子部品であることを意味します。

4.イラストページの-----枠は、組構成であることを意味します。

5.リストページの"☆"(消耗部品)、“◎”(オプション部品)の印がついた部品は、予備を準備しておくことをお奨めします。

6.リストページのGG、BB等の記号は、仕向地を示します。

記号	仕向地
GG	中国
BB	ヨーロッパ
EE	日本
AA	中国、ヨーロッパ、日本を除く

CONTENTS

目次

1. MACHINE FRAME & MISCELLANEOUS COVER COMPONENTS.....	1
頭部・外装関係	
2. BOBBIN WINDER COMPONENTS	3
糸巻装置関係	
3. MAIN SHAFT & NEEDLE BAR COMPONENTS.....	5
上軸・針棒関係	
4. HAND LIFTER & TENSION RELEASE COMPONENTS.....	7
押え上げ・糸緩め関係	
5. FEED ADJUST MECHANISM COMPONENTS	9
送り調節関係	
6. HORIZONTAL FEED, VERTICAL FEED & HOOK DRIVING SHAFT COMPONENTS.....	11
水平送り・上下送り・釜軸関係	
7. THREAD TRIMMER COMPONENTS.....	13
糸切り装置関係	
8. OIL LUBRICATION COMPONENTS.....	15
給油関係	
9. AUTOMATIC REVERSE FEED COMPONENTS.....	17
自動逆送り関係	
10. WIPER COMPONENTS (FOR DDL-9000B-**-WB)	19
ワイパー関係 (DDL-9000B-**-WB用)	
11. THREAD STAND COMPONENTS.....	20
糸立装置関係	
12. UNDER COVER COMPONENTS.....	21
アンダーカバー関係	
13. ACCESSORIE PART COMPONENTS	22
付属品関係	
14. EXCLUSIVE PARTS DDL-9000B DS	23
DDL-9000B DS 専用部品	
15. EXCLUSIVE PARTS DDL-9000B MS,MA.....	24
DDL-9000B MS, MA 専用部品	
16. EXCLUSIVE PARTS DDL-9000B SH	25
DDL-9000B SH 専用部品	
17. TABLE & STAND COMPONENTS.....	27
脚卓関係	
18. SPECIAL ORDER PART.....	29
特別注文部品	
19. LIST FOR INFORMATION OF CHANGE.....	30
変更情報リスト	
NUMERICAL INDEX OF PARTS.....	31
索引	

1. MACHINE FRAME & MISCELLANEOUS COVER COMPONENTS

頭部・外装関係

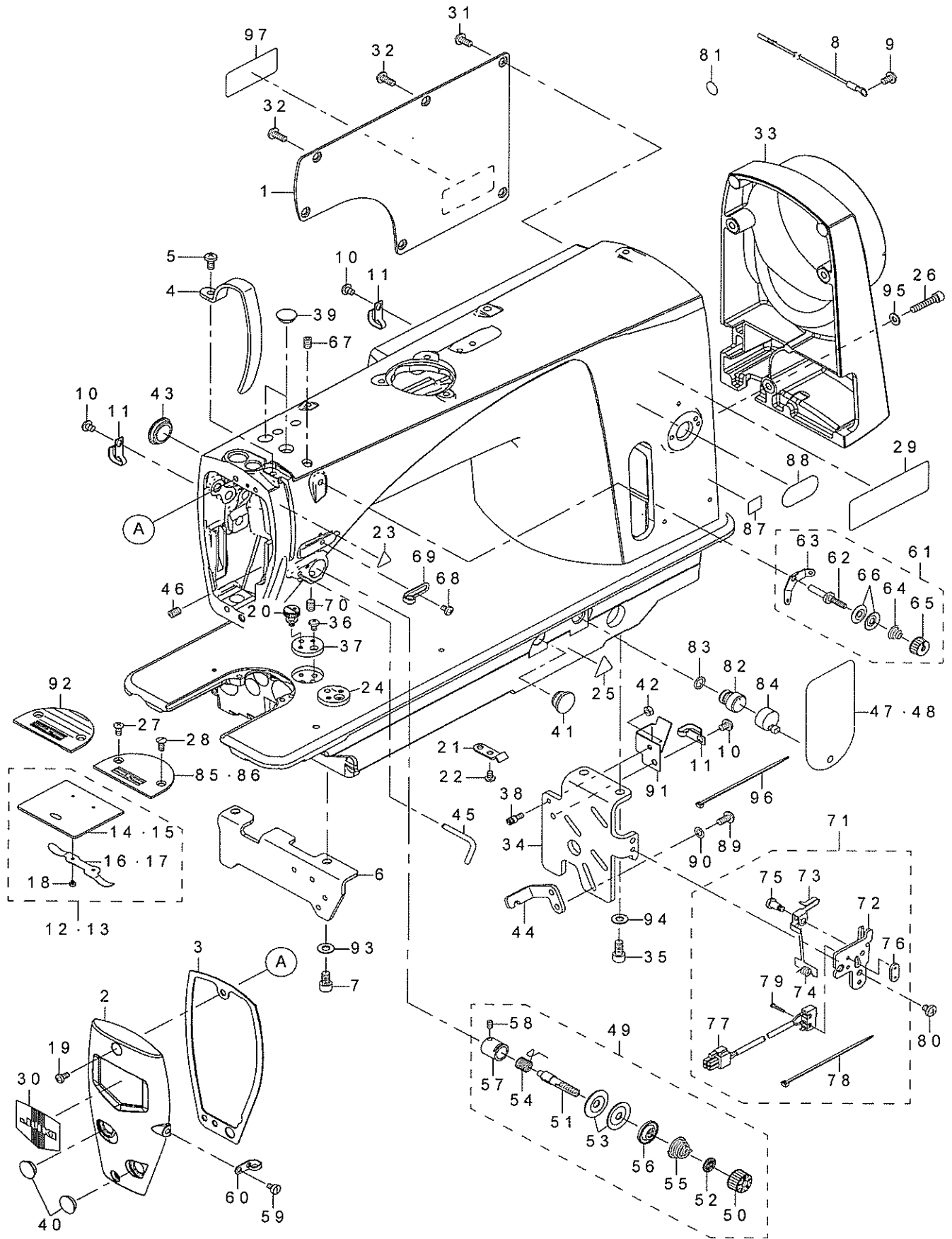

REF NO	NOTE	PART NO	DESCRIPTION	品名	Qty
1		400-37158	SIDE PLATE	芯板	1
2		400-41161	FACE PLATE	面板	1
3		400-52819	FACE PLATE PACKING	面板パッキン	1
4		236-00505	THREAD TAKE-UP LEVER COVER	天秤カバー	1
5		SM-4051055-SP	SCREW	なべねじ	1
6		400-86713	BED_STUD_A	ベッド支柱 A	1
7	*	SM-6061002-TP	SCREW M6 L=10	六角穴ボルト M6 L=10	2
8		229-51552	GROUND WIRE ASM.	アースコード (組)	1
9		SM-4050855-SP	SCREW	なべねじ M5 L=8	1
10		SM-4050655-SP	SCREW M5 L=6	なべ小ねじ M5 L=6	3
11		400-22407	CORD HOLDER	コード押え	3
12	#01	229-01250	SLIDE PLATE ASM.	滑り板 (組)	1
13	#02	229-02753	SLIDE PLATE ASM.	滑り板 (組)	1
14		229-01201	SLIDE PLATE	滑り板	(1)
15		229-02704	SLIDE PLATE	滑り板	(1)
16		229-01300	SLIDE PLATE SPRING	滑り板ばね	(1)
17		229-01300	SLIDE PLATE SPRING	滑り板ばね	(1)
18		SS-6060210-SP	SCREW 3/32-56 L=1.9	平ねじ 3/32-56 L=1.9	(2)
19		SM-4050855-SP	SCREW	なべねじ M5 L=8	2
20	#07	400-69110	ATTACHMENT FIXATION SCREW	アタッチメント固定ねじ	1
21		229-44508	WIRE PRESSER A	ワイヤー押え A	1
22		SM-4040655-SP	SCREW M4 L=6	なべ小ねじ M4 L=6	1
23		CM-3002000-01	ATTENTION SEAL	指げが注意シール (16)	1
24	#07	400-69097	RULER PLATE I	定規止め版 I	1
25		CM-3002000-03	ATTENTION LABEL	指げが注意シール (31.5)	1
26	*	SM-6052502-TP	SCREW M5X25	六角穴ボルト M5 X 25	3
27		SM-2040955-TP	SCREW M4 L=8.5	丸皿ねじ M4 L=8.5	1
28		SM-2040750-TP	SCREW M4 L=7.4	丸皿ねじ M4 L=7.4	1
29		CM-3013000-01	SAFETY LABEL	顔面注意安全シール (横)	1
30		229-02506	FACE PLATE	面板化粧板	1
31		SM-4051055-SP	SCREW	なべねじ	4
32		SM-4051255-SP	SCREW M5 L=12	なべねじ M5 L=12	2
33		400-86732	PULLEY COVER	プーリーカバー	1
34		400-86714	BED_STUD_B	ベッド支柱 B	1
35	*	SM-6061202-TP	SCREW M6 L=12	六角穴ボルト M6 L=12	2
36		SM-4040655-SP	SCREW M4 L=6	なべ小ねじ M4 L=6	1
37		400-35589	RULER PLATE	定規板	1
38		400-91461	FEED LEVER SPRING HOOK	送りレバーばね掛け	1
39		TA-1250406-R0	RUBBER PLUG D=12.5 L=4	止め栓 D=12.5 L=4	2
40		TA-1250406-R0	RUBBER PLUG D=12.5 L=4	止め栓 D=12.5 L=4	2
41		TA-1470704-R0	RUBBER PLUG	止め栓	1
42		NM-6040001-SP	NUT M4X0.7	六角ナット M4 X 0.7 1種	1
43		TA-1250406-R0	RUBBER PLUG D=12.5 L=4	止め栓 D=12.5 L=4	1
44		400-86728	FEED_ADJUSTING_SPRING_PLATE	送り調節ばね掛け	1
45		400-52933	ARM THREAD GUIDE C	アーム糸案内 C	1
46		SM-80608A2-TP	SCREW M6 L=8	六角穴付き止めねじ M6	1
47		236-40006	SHEET	エアー抜きキャップ注意シート	1
48	#06	400-37488	SHEET	エアー抜きキャップ注意シート	1
49		400-24843	THREAD TENSION DISK ASM	糸調子組	1
50		236-26005	THREAD TENSION NUT	糸調子ナット	(1)
51		B3115-552-000	TENSION POST	糸調子棒	(1)
52		B3120-125-000	ROTATING STOPPER	糸調子皿回転止め	(1)
53		B3126-012-000	THREAD TENSION DISK	糸調子皿	(2)
54	*	B3128-012-000	TAKE-UP SPRING	糸取りばね	(1)
55		B3129-012-A00	TENSION SPRING	糸調子ばね A	(1)
56		B3132-552-000	THREAD TENSION DISK PRESSER	糸調子皿押え	(1)
57		400-24845	TENSION POST SOCKET ASM.	糸調子棒台 (組)	(1)
58		SS-8090670-SP	SCREW 9/64-40 L=5.5	止めねじ 9/64-40 L=5.5	(1)
59		SS-6110610-TP	SCREW 11/64-40 L=6	平ねじ 11/64-40 L=6	1
60		229-20607	ARM THREAD GUIDE B	アーム糸案内 B	1
61		110-73954	THREAD TENSION ASM	第一糸調子組	1
62		110-45002	FIRST TENSION POST	第一糸調子棒	(1)
63		110-45200	THREAD TENSION GUIDE	第一糸調子案内	(1)
64		110-93606	THREAD TENSION SPRING	第一糸調子ばね	(1)
65		110-72402	THREAD TENSION NUT	第一糸調子ナット	(1)
66		B3214-047-000	BOBBIN WINDER TENSION DISC	第一糸調子皿	(2)
67		SM-80608A2-TP	L=8SCREW M6 L=8	六角穴付き止めねじ M6	1
68		SM-5040655-SN	SCREW	バインドねじ	1
69		236-26104	ARM THREAD GUIDE A	アーム糸案内 A	1
70		SM-80608A2-TP	L=8SCREW M6 L=8	六角穴付き止めねじ M6	1
71		400-86659	SAFETY_SWITCH_ASM	安全スイッチ台組	1
72		400-86660	SAFETY_SWITCH_BASE	安全スイッチ台	(1)
73		236-38109	SAFETY_SWITCH_ARM	安全スイッチ腕	(1)
74		236-38208	SAFETY_SWITCH_SPRING	安全スイッチ戻しばね	(1)
75		236-38307	SAFETY_SWITCH_ARM_SHAFT	安全スイッチ腕支点軸	(1)
76		236-38406	SAFETY_SWITCH_NUT	安全スイッチ止め板	(1)
77		236-38554	SAFETY_SWITCH_CORD_ASM	安全スイッチコード (組)	(1)
78		EA-9500B01-00	CABLE BAND	束縛バンド	(1)
79		SM-4021201-SC	SCREW M2 L=12	なべ小ねじ M2 L=12	(2)
80		SM-4050655-SP	SCREW M5 L=6	なべ小ねじ M5 L=6	1
81		229-01805	GROUND MARK	グラウンドマーク	1
82		236-29900	AIR-DISCHARGING	エアー抜き	1
83		RO-0801502-00	RUBBER RING	Oリング	1
84		236-01305	AIR-DISCHARGING CAP	エアー抜きキャップ	1
85	#03	B1109-012-10B	THROAT PLATE (I)	針板 I	1
86	#04	T10-28008	THROAT PLATE	針板	1
87	#05	CM-6001001-01	WEEE MARK LABEL S	WEEE マーク ラベル S	1
88	#06	CM-6006001-01	CHINA ENVIRONMENT LABEL	中国省エネ・環境適合ラベル	1
89		SM-4051055-SP	SCREW	なべねじ	2
90		WP-0550800-SP	WASHER 5.5X10X0.8	平座金 5.5 X 10 X 0.8	2
91		400-91397	CABLE COVER	ケーブルカバー	1
92	#06	B1109-552-000	THROAT PLATE	針板	1
93	*	WP-0621016-SD	WASHER 6.2X13X1	平座金 6.2 X 13 X 1	2
94	*	WP-0621016-SD	WASHER 6.2X13X1	平座金 6.2 X 13 X 1	2
95	*	WP-0501016-SD	WASHER 5X10.5X1	平座金 5 X 10.5 X 1	3
96	*	EA-9500B01-00	CABLE BAND	束縛バンド	1
97	* #05	400-94561	SEWING MACHINE LABEL (EU)	単体顔面銘板 (EU)	1
NOTE(注記)			#01 FOR BB,EE #02 FOR AA,GG #03 FOR AA,BB #04 FOR EE #05 FOR BB #06 FOR GG #07 OPTIONAL PARTS	BB, EE 用 AA, GG 用 AA, BB 用 EE 用 BB 用 GG 用 オプション部品	

*ABOUT THE DESTINATION, THE SPREAD "HOW TO MAKE USE OF THIS PARTS LIST" PLEASE SEE
仕向地については、見開きの (パーツリストご利用に際して) を参照して下さい。

2. BOBBIN WINDER COMPONENTS

糸巻装置関係

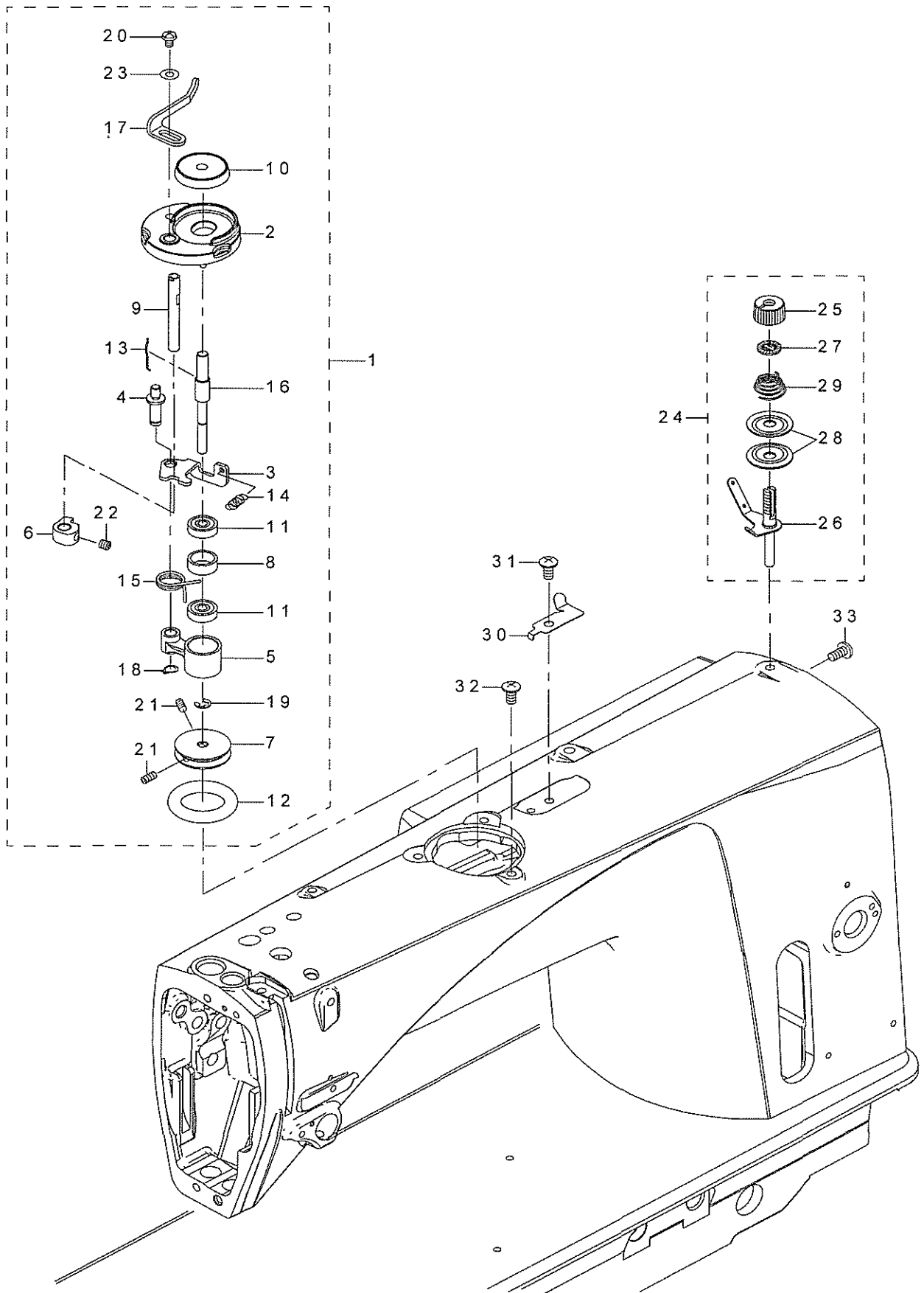

REF.NO	NOTE	PART NO	DESCRIPTION	品名	Qty
1		400-23021	BOBBIN WINDER UNIT	糸巻き装置組	1
2		262-60109	BTW_BASE	糸巻き取付台	(1)
3		262-60208	BTW_CAM_PLATE	糸巻き調節板	(1)
4		262-60307	BTW_BASE_SHAFT	糸巻き調節板軸	(1)
5		262-60406	BTW_SHAFT_BASE	糸巻き腕	(1)
6		262-60505	BTW_CAM_LEVER	糸巻きカム	(1)
7		262-60604	BTW_WHEEL	糸巻き車	(1)
8		262-60802	BTW_BEARING_SPACER	ベアリングスペーサー	(1)
9		262-61008	BTW_LEVER_SHAFT	糸巻きレバー軸	(1)
10		262-61206	BTW_SPACER	ボビン座	(1)
11		262-61305	BTW_BEARING	糸巻き軸ベアリング	(2)
12	☆	262-61503	BTW_WHEEL_RUBBER	糸巻き摩擦車	(1)
13	☆	262-61602	BOBBIN_SPRING	ボビン止めばね	(1)
14		262-61701	BTW_SPRING	糸巻き調節板戻しばね	(1)
15		400-11144	BTW_TORSION_SPRING	糸巻きねじりばね	(1)
16		400-14837	BTW_SHAFT	糸巻き軸	(1)
17		400-23022	BTW_LEVER	糸巻きレバー	(1)
18		RC-0560711-KP	RETAINING RING	C 形止め輪	(1)
19		RE-0400000-K0	E-RING 4	E 形止め輪 4	(1)
20		SM-5040655-SN	SCREW	バインドねじ	(1)
21		SM-8040802-YP	SCREW M4X8	止めねじ M 4 X 0. 7 L = 8	(2)
22		SM-8050502-TP	SCREW M5 L=5	止めねじ	(1)
23		WP-0450826-SC	WASHER 4.5X10X0.8	平座金 4. 5 X 10 X 0. 8	(1)
24		400-88958	BOBBIN THREAD TENSION ASM.	糸巻き糸調子 (組)	1
25		229-21308	THREAD TENSION NUT	糸調子ナット	(1)
26		400-88959	BOBBIN THREAD TENSION ROD ASM.	糸巻き糸調子棒 (結合)	(1)
27		229-21407	ROTATION STOPPER	糸調子皿回転止め	(1)
28		229-21506	THREAD TENSION DISK	糸調子皿	(2)
29		229-21704	THREAD TENSION SPRING, A	糸調子ばね (A)	(1)
30	☆	400-37008	THREAD_CUTTER	糸切り保持板	1
31		SM-0051001-SC	SCREW	トラスねじ M 5 L = 10	1
32		SM-0051001-SC	SCREW	トラスねじ M 5 L = 10	3
33		SM-4051055-SP	SCREW	なべねじ	1

3. MAIN SHAFT & NEEDLE BAR COMPONENTS

上軸・針棒関係

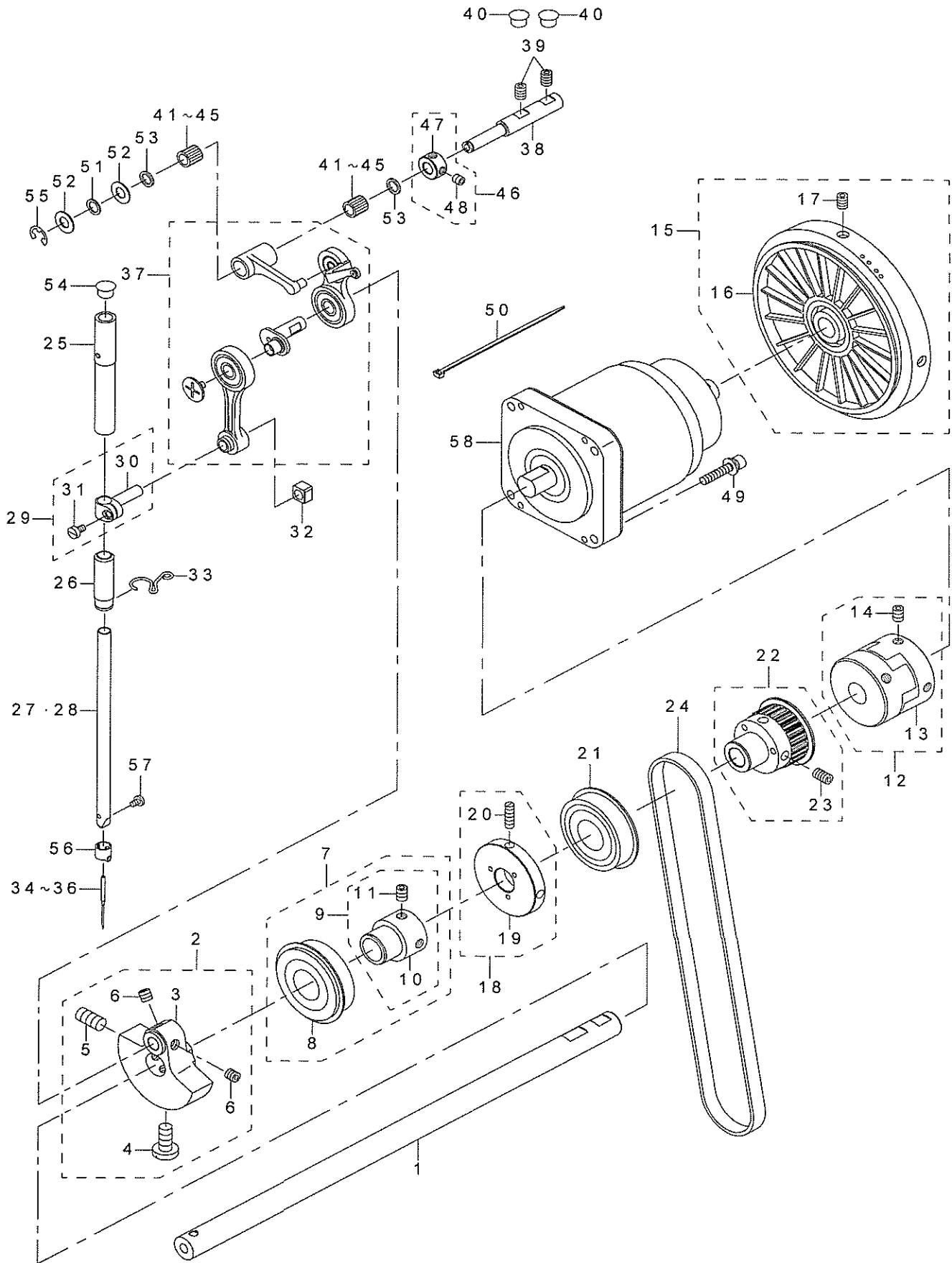

REF.NO	NOTE	PART NO	DESCRIPTION	品名	Qty
1		400-86597	MAIN_SHAFT	上軸	1
2		400-37003	ASSY_COUNTER_WEIGHT	釣合錘 (組)	1
3		400-25729	COUNTER_WEIGHT	釣合錘	(1)
4		400-04171	COUNTER_WEIGHT_SCREW	ねじ	(1)
5		SM-8081652-TP	SCREW M8 L=16	ねじ M 8 L = 16	(1)
6		SM-80608A2-TP	SCREW M6 L=6	六角穴付き止めねじ M 6	(2)
7		400-86733	BEARING_SUPPORT_COMPL.	上軸前ベアリング結合	1
8		SB-1200027-00	BEARING	ころがり軸受	(1)
9		400-44857	FRONT BEARING SUPPORT ASM.	上軸前ベアリング受 (組)	(1)
10		236-05207	MAIN SHAFT BEARING SUPPORT	上軸前ベアリング受	(1)
11		SM-80608A2-TP	SCREW M6 L=8	六角穴付き止めねじ M 6	(2)
12		400-51473	COUPLING ASM.	カップリング組	1
13		400-51474	COUPLING	カップリング	(1)
14		SM-80608A2-TP	L=8SCREW M6 L=8	六角穴付き止めねじ M 6	(4)
15		400-37007	HAND WHEEL ASM.	はずみ車 (組)	1
16		400-37006	HAND WHEEL	はずみ車	(1)
17		SM-80608A2-TP	SCREW M6 L=8	六角穴付き止めねじ M 6	(2)
18		400-20454	BTW DRIVING WHEEL ASM.	糸巻き駆動車組	1
19		400-20455	BTW DRIVING WHEEL	糸巻き駆動車	(1)
20		SM-8051610-SP	SCREW M5 L=16	止めねじ M 5 L = 16	(2)
21		SB-1200027-00	BEARING	ころがり軸受	1
22		400-86729	UPPER_SPROCKET_ASM	上スプロケット組	1
23		SM-80608A2-TP	SCREW M6 L=8	六角穴付き止めねじ M 6 L = 8	(2)
24		400-86731	TIMING BELT_550	タイミングベルト	1
25		236-08003	NEEDLE BAR METAL,UPPER	針棒上メタル	1
26		236-08102	NEEDLE BAR METAL,LOWER	針棒下メタル	1
27	* #01	228-86907	NEEDLE BAR (A)	針棒 (A)	1
28	* #02	228-87004	NEEDLE BAR (B)	針棒 (B)	1
29		229-06457	NEEDLE BAR HOLDER ASM.	針棒抱き (組)	1
30		229-06408	NEEDLE ROD HOLDER	針棒抱き	(1)
31		SS-6090670-TP	SCREW 9/64-40 L=6	平ねじ 9/64-40 L = 6	(1)
32		B1414-555-000	SLIDE BLOCK	針棒抱き 案内コ口	1
33		236-26203	NEEDLE BAR THREAD GUIDE	針棒糸案内	1
34	☆ #04	MDB-100B1100	NEEDLE DBX1 #11	針 DBX1 #11	1
35	☆ #02	MC-2005007-50	NEEDLE 134 NM75	針 シュメツ 134 NM 75	1
36	☆ #03	MDB-100B1400	NEEDLE DBX1 #14	針 DBX1 #14	1
37		400-37370	THREAD TAKE UP COMP.	天秤びん (結合)	1
38		400-90527	TAKE UP CRANK SHAFT	天秤支え軸	1
39		SM-80608A2-TP	SCREW M6 L=8	六角穴付き止めねじ M 6	2
40		TA-0850604-R0	RUBBER PLUG	止め栓	2
41	#05	SB-3070002-00	BEARING	ころがり軸受	2
42	#05	SB-3070002-0A	BEARING	ころがり軸受	2
43	#05	SB-3070002-0B	BEARING	ころがり軸受	2
44	#05	SB-3070002-0C	BEARING	ころがり軸受	2
45	#05	SB-3070002-0D	BEARING	ころがり軸受	2
46	*	400-32269	THRUST COLLAR	スラストカラー	1
47		CS-1000881-TP	THRUST COLLAR	スラスト受 D = 10 W = 8	(1)
48		SM-8050412-TP	SCREW M5 L=4	止めねじ M 5 L = 4	(2)
49		SL-6052592-TN	BOLT	壓金付き六角穴ボルト	4
50		EA-9500B01-00	CABLE BAND	束線バンド	2
51		400-90529	TAKE UP CRANK SHAFT WASHER B	天秤クランク軸座金 B	1
52		400-90528	TAKE UP CRANK SHAFT WASHER A	天秤クランク軸座金 A	2
53		228-91204	BEARING SUPPORT	ベアリング押え	2
54		TA-0850604-R0	RUBBER PLUG	止め栓	1
55		RE-0600000-K0	E-RING 6	E 形止め輪 6	1
56		229-06309	NEEDLE BAR THREAD GUIDE	針棒糸掛け	1
57	☆	SS-7080510-TP	SCREW 1/8-44 L=4.5	丸平ねじ 1/8-44 L = 4. 5	1
58		400-89196	AC SERVO MOTOR	小型サーボモータ	1
		NOTE(注記)	#01...FOR EE,AA,GG #02...FOR BB #03...FOR GG #04...FOR EE,AA #05...SELECTIVE PARTS	EE, AA, GG 用 BB 用 GG 用 EE, AA 用 選択部品	

*ABOUT THE DESTINATION, THE SPREAD *HOW TO MAKE USE OF THIS PARTS LIST* PLEASE SEE.
仕向地については、見開きの (パーツリストご利用に際して) を参照して下さい。

4. HAND LIFTER & TENSION RELEASE COMPONENTS

押え上げ・糸緩め関係

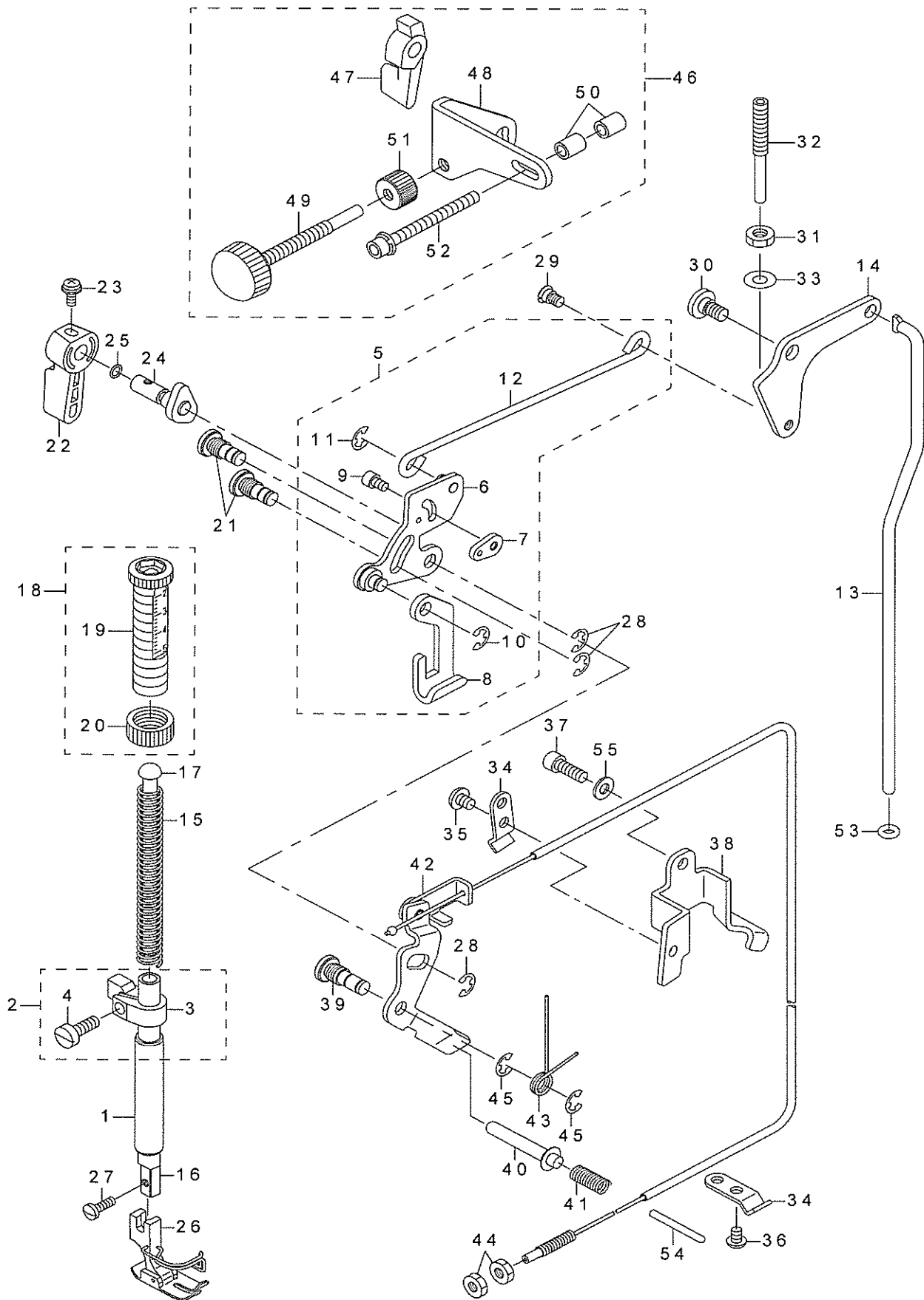

REF.NO	NOTE	PART NO	DESCRIPTION	品名	Qty
1		236-09001	BUSHING	押え棒メタル	1
2		400-86606	PRESSER_BAR_GUIDE_BRACKET_ASM.	押え棒抱き組	1
3		400-86607	PRESSER_BAR_GUIDE_BRACKET	押え棒抱き	(1)
4		SM-6051400-SP	SCREW	平ねじ	(1)
5		236-09357	LIFTING LEVER CONNECT ROD ASM.	膝上げ横棒 (組)	1
6		236-09456	LIFTING LINK COMPL.	引き上げリンク (結合)	(1)
7		236-09605	PLATE	糸緩め切換板	(1)
8		229-08008	LIFTING PLATE	引き上げ板	(1)
9		SM-6040602-TP	SCREW M4 L=6	六角穴ボルト M 4 X 0. 7 L =6	(1)
10		RE-0500000-K0	E-RING	E 形止め輪 5	(1)
11		RE-0500000-K0	E-RING	E 形止め輪 5	(1)
12		236-09308	LIFTING LEVER CONNECT ROD	膝上げ横棒	(1)
13		400-86760	CONNECTING ROD	膝上げ連結棒	1
14		236-09704	LIFTING LEVER LINK	膝上げリンク	1
15		229-07406	PRESSER SPRING	押え調節ばね	1
16		236-10207	PRESSER BAR	押え棒	1
17		236-10306	PRESSER GUIDE BAR	押え案内棒	1
18		400-37359	PRESSER SPRING REGURATOR ASM.	押え調節ねじ (組)	1
19		400-37141	PRESSER SPRING REGULATOR	押えばね調節ねじ	(1)
20		400-37144	PRESSER SPRING REGULATOR NUT	押え調節ばねねじナット	(1)
21		400-50583	LINK SHAFT	引き上げリンク軸	2
22		229-07802	HAND LIFTER	押え上げレバー	1
23		B1521-555-000	SCREW	押え上げレバー止めねじ	1
24		229-08552	HAND LIFTER CAM ASM.	押え上げカム (組)	1
25		RO-0371801-00	RUBBER RING	O リング	1
26		B1524-012-0BA	PRESSER FOOT ASM.	自由押え (針方一付) 組	1
27		SS-7091110-TP	SCREW 9/64-40 L=10.5	丸平ねじ 9/64-40 L = 10. 5	1
28		RE-0500000-K0	E-RING	E 形止め輪 5	3
29		229-08909	HINGE SCREW	膝上げ横棒段ねじ	1
30		400-82078	SHOULDER SCREW D=7.24 H=3.3	段ねじ D = 7. 24 H = 3. 3	1
31		NM-6060003-SE	NUT FOR BRACKET	六角ナット M 6 2種	1
32		400-36706	ADJUSTING SCREW	微量押え上げねじ	1
33		WP-0621016-SD	WASHER 6.2X13X1	平座金 6. 2 X 13 X 1	1
34		229-44508	WIRE PRESSER A	ワイヤー押え A	2
35		SM-4050655-SP	SCREW M5 L=6	なべ小ねじ M 5 L = 6	1
36		SM-4040655-SP	SCREW M4 L=6	なべ小ねじ M 4 L = 6	1
37	*	SM-6051402-TP	SCREW M5X0.8 L=14	六角穴ボルト	1
38		400-86643	WIRE HOLDER	ワイヤー押え	1
39		400-50582	TENSION RELEASE SHAFT	糸緩め板軸	1
40		229-20300	THREAD RELEASE SUPPORTING PIN	糸緩め補助ピン	1
41		229-20409	THREAD RELEASE PIN SPRING	糸緩めピンばね	1
42		236-26351	THREAD TENSION RELEASE WIRE	糸緩めワイヤー (組)	1
43		236-26807	TENSION RELEASE RETURN SPRING	糸緩め板戻しばね	1
44		NS-6620310-SP	NUT 3/16-32	六角ナット 3/16-32	2
45		RE-0500000-K0	E-RING	E 形止め輪 5	2
46	#01	400-56622	MINUTE LIFTING DEVICE ASM.	微量押え上げ装置組	1
47		236-11106	HAND LIFTER	押え上げレバー	(1)
48		236-10504	STOPPER BASE	ストッパー台	(1)
49		236-10652	STOPPER SCREW ASM.	ストッパーねじ (組)	(1)
50		D5119-206-K0K	SPACER	スペーサ	(2)
51		236-10702	STOPPER SCREW NUT	ストッパーねじナット	(1)
52		SL-6053592-TN	BOLT	座金付き六角穴ボルト	(1)
53		RO-0442401-00	RUBBER RING	O リング	1
54		B3118-552-F00	TENSION RELEASING PIN	糸緩めピン F	1
55	*	WP-0501016-SD	WASHER 5X10.5X1	平座金 5 X 10. 5 X 1	1
		NOTE(注記)	#01...OPTIONAL PARTS	オプション部品	

5. FEED ADJUST MECHANISM COMPONENTS

送り調節関係

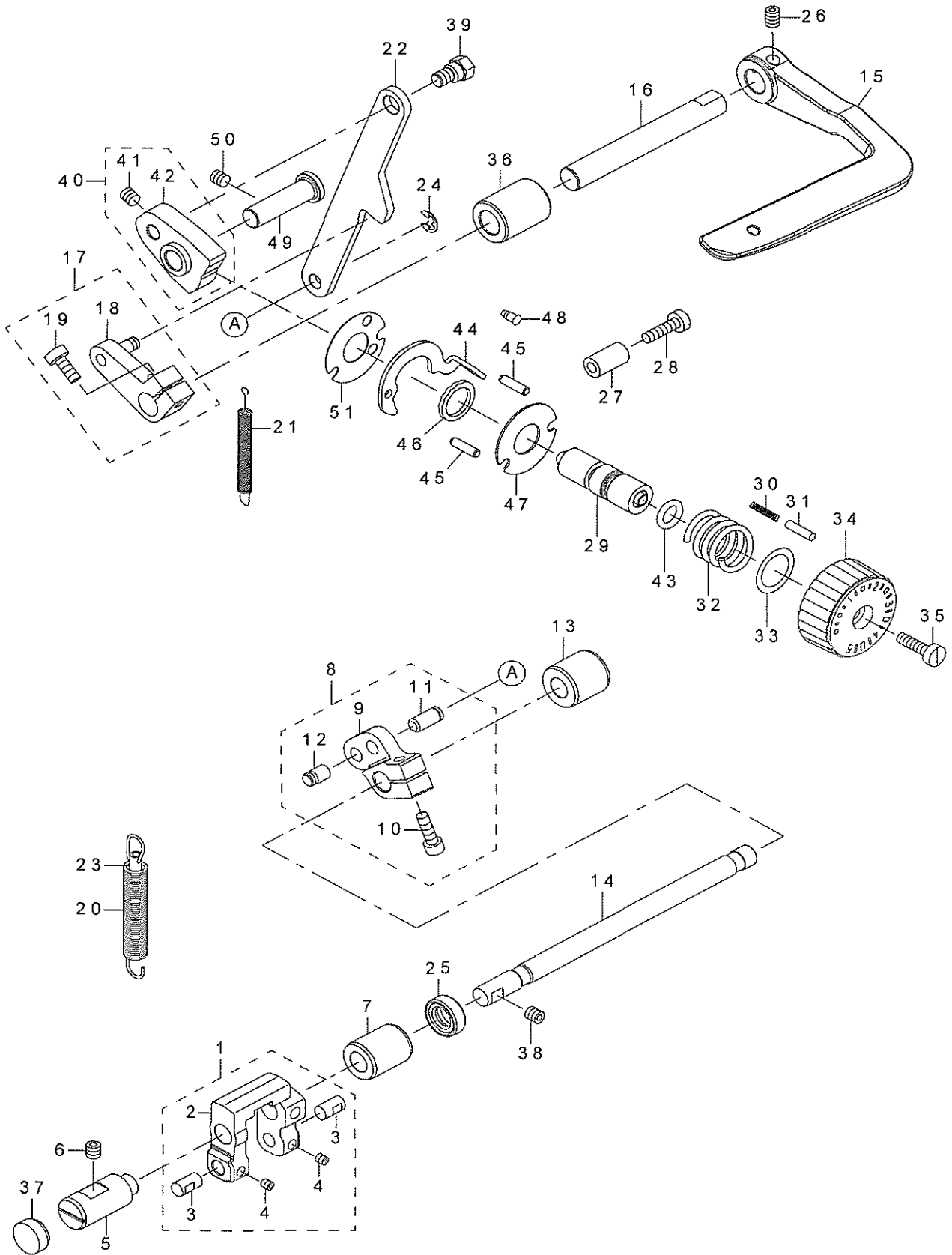

REF.NO	NOTE	PART NO	DESCRIPTION	品名	Qty
1		400-86735	ADJUSTING_LINK_ASM.	送り調節リンク (組)	1
2		400-86695	FEED_ADJUSTING_LINK	送り調節リンク	(1)
3		400-86696	FEED_ADJUSTING_LINK_PIN	調節リンクピン	(2)
4		SM-80506A2-TP	SCREW M5 L=6	六角穴付き止めねじ M5 L=6	(2)
5		400-86608	ADJUSTING_LINK_FULCRUM_SHAFT	調節リンク支点軸	1
6		SM-80606A2-TP	SCREW M6 L=6	六角穴付き止めねじ M6 L=6	1
7		400-86615	FEED_CHANGING_SHAFT_METAL_A	送り変換軸メタル A	1
8		400-86704	FEED_CHANGING_SHAFT_ARM_ASM.	送り変換軸腕 (組)	1
9		400-86705	FEED_CHANGING_SHAFT_ARM	送り変換軸腕	(1)
10		SM-6051602-TP	SCREW M5X0.8 L=16	六角穴ボルト M5 X 0.8 L=16	(1)
11		229-10509	FEED_ADJUSTING_LINK_PIN	送り調節リンクピン	(1)
12		400-86706	FEED_CHANGING_SPRING_PIN	送り変換軸ばね掛けピン	(1)
13		400-86616	FEED_CHANGING_SHAFT_METAL_B	送り変換軸メタル B	1
14		400-86614	FEED_CHANGING_SHAFT	送り変換軸	1
15		400-86738	REVERSE_FEED_LEVER	逆送りレバー	1
16		236-13706	FEED_LEVER_SHAFT	送りレバー軸	1
17		400-86674	FEED_LEVER_ARM_ASM.	送りレバー腕 (組)	1
18		400-86675	FEED_LEVER_ARM	送りレバー腕	(1)
19	*	SM-6051602-TP	SCREW M5X0.8 L=16	六角穴ボルト M5 X 0.8 L=16	(1)
20		400-86737	FEED_ADJUSTING_SPRING	送り調節ばね	1
21		400-86739	FEED_LEVER_SPRING	送りレバーばね	1
22		400-86609	FEED_ADJUSTING_ROD	送り調節ロッド	1
23		236-30007	TUBE	チューブ	0.1
24		RE-0500000-K0	E-RING	E 形止め輪 5	1
25		236-12609	FEED_CHANGING_SHAFT_OIL_SEAL	変換軸オイルシール	1
26		SM-80608A2-TP	SCREW M6 L=8	六角穴付き止めねじ M6 L=8	2
27		229-52501	BACK_LEVER_STOPPER	バックレバーストッパー	1
28		SM-6051850-TP	SCREW M5 L=18	平小ねじ M5 L=18	1
29	*	229-11804	FEED_REGULATOR_SCREW	送り調節ねじ	1
30		229-12109	FEED_REGULATOR_PIN_SPRING	送り調節ピンばね	1
31		229-12000	FEED_REGULATOR_PIN	送り調節ピン	1
32	*	235-34506	FEED_DIAL_SPRING	送りダイヤルばね	1
33		WP-1751616-SD	WASHER 17.5X24X1.6	平座金 17.5 X 24 X 1.6	1
34		400-36433	FEED_DIAL	送りダイヤル	1
35		SS-6121860-SP	SCREW 3/16-28 L=18	平ねじ 3/16-28 L=18	1
36		400-86617	FEED_LEVER_SHAFT_METAL	送りレバー軸メタル	1
37		400-86736	RUBBER_PLUG	支点軸穴キャップ	1
38		SM-80606A2-TP	SCREW M6 L=6	六角穴付き止めねじ M6 L=6	1
39		236-13409	FEED_ADJUSTING_PIN	送り調節ピン	1
40	*	400-95847	FEED_REGULATOR_ASM.	送り調節器 (組)	1
41		SM-80606A2-TP	SCREW M6 L=6	六角穴付き止めねじ M6 L=6	(1)
42		400-86610	FEED_REGULATOR	送り調節器	(1)
43		RO-0922702-00	RUBBER_RING	O リング	1
44		400-86612	FEED_REGULATOR_STOPPER	送り調節ストッパー	1
45		400-86613	FEED_REGULATOR_STOPPER_PIN	送り調節ストッパーピン	2
46		400-90100	FEED_DIAL_STOPPER_WASHER_A	送りダイヤルストッパー座金 A	1
47		400-90101	FEED_DIAL_STOPPER_WASHER_B	送りダイヤルストッパー座金 B	1
48		110-01005	SCREW	送り調節ストッパーラッチピン	1
49		400-06716	THREAD_TRIMMER_SHAFT	送り調節支点軸	1
50		SM-80606A2-TP	SCREW M6 L=6	六角穴付き止めねじ M6 L=6	1
51	*	400-93035	FEED_DIAL_STOPPER_WASHER_C	送りダイヤルストッパー座金 C	1

6. HORIZONTAL FEED, VERTICAL FEED & HOOK DRIVING SHAFT COMPONENTS

水平送り・上下送り・釜軸関係

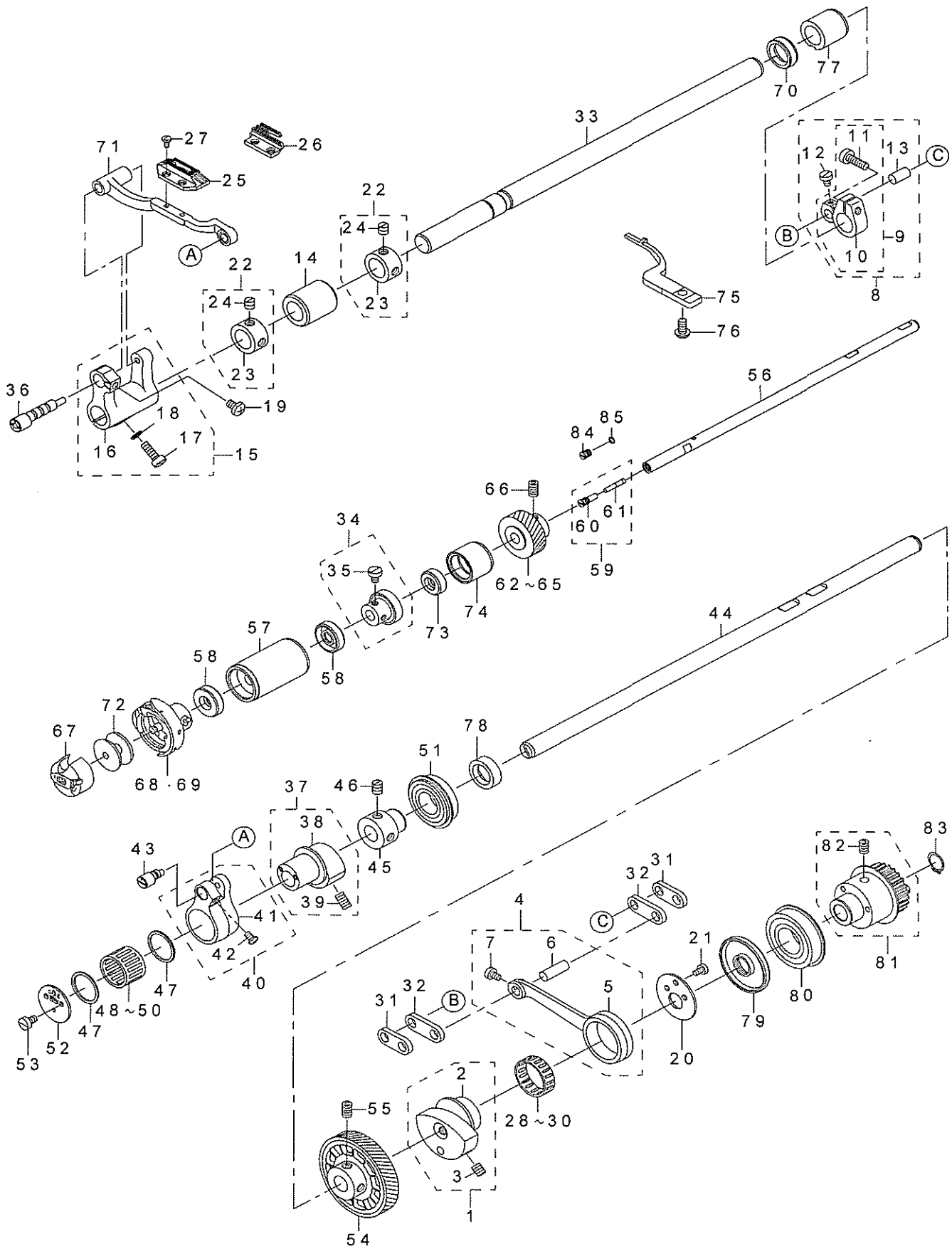

REF NO	NOTE	PART NO	DESCRIPTION	品名	Qty
1		400-37192	FEED ROCKER CAM ASM.	水平送りカム (組)	1
2		236-16006	FEED ROCKER CAM	水平送りカム	(1)
3		SS-8150822-TP	SCREW 15/64-28 L=8	止めねじ 15/64-28 L=8	(2)
4		400-37365	FEED ROCKER ROD ASM.	水平送りロッド (組)	1
5		400-26277	FEED ROCKER ROD	水平送りロッド	(1)
6		229-11101	WALKING FOOT PIN C	水平送りピンC	(1)
7		SS-6090620-TP	SCREW	平ねじ	(1)
8		400-61246	FEED ROCKER ARM ALL ASM.	水平送り腕総組	1
9		400-58504	FEED ROCKER ARM ASM.	水平送り腕組	(1)
10		400-42079	FEED ROCKER ARM	水平送り腕	(1)
11		SS-6121610-SP	SCREW 3/16-28 L=15.5	平ねじ 3/16-28 L=15.5	(1)
12		SS-6090620-TP	SCREW	平ねじ	(1)
13		229-11002	WALKING FOOT PIN B	水平送りピンB	(1)
14		236-16709	FEED ROCKER SHAFT METAL	水平送り軸メタル	1
15		400-37005	ASSY_FEED_ROCKER_BASE_ARM	水平送り台腕 (組)	1
16		400-26281	FEED ROCKER BASE ARM	水平送り台腕	(1)
17		SM-6051400-SP	SCREW	平ねじ	(1)
18		WP-0480856-SP	WASHER 4.8X8.4X0.8	平座金 4.8 X 8.4 X 0.8	(1)
19		SM-4050855-SP	SCREW	なべねじ M5 L=8	1
20		236-16204	FEED ROCKER CAM PLATE	水平送りカム蓋	1
21		SS-6090670-TP	SCREW 9/64-40 L=6	平ねじ 9/64-40 L=6	2
22		229-04155	MAIN SHAFT THRUST COLLAR ASM	上軸スラスト受 (組)	2
23		229-04106	MAIN SHAFT THRUST COLLAR	上軸スラスト受	(1)
24		SS-8660610-TP	SCREW 1/4-40 L=6	止めねじ 1/4-40 L=6	(2)
25	#01	B1613-012-100	FEED DOG I	送り歯 I	1
26	#02	236-14506	FEED DOG A	送り歯 (A)	1
27		SS-4080620-TP	SCREW 1/8-44 L=6	なべねじ 1/8-44 L=6	2
28	#05	B4123-522-00A	NEEDLE BEARING	メス ニードルローラ A	1
29	#05	B4123-522-00B	NEEDLE ROLLAR	メス ニードルローラ B	1
30	#05	B4123-522-00C	NEEDLE ROLLAR	メス ニードルローラ C	1
31		400-26278	CONNECTING LINK A	連結リンク A	2
32		236-16402	CONNECTING LINK B	連結リンク B	2
33		236-16600	FEED ROCKER SHAFT	水平送り軸	1
34		400-86743	BEARING SUPPORT ASM.	釜軸ベアリング受け (組)	1
35		SS-6110650-TP	SCREW 11/64-40 L=5.5	平ねじ 11/64-40 L=5.5	(2)
36		400-26282	FEED ROCKER BASE SHAFT	水平送り台軸	1
37		400-00391	VERTICAL FEED CAM ASM. 5	上下送りカム5 (組)	1
38		400-00392	VERTICAL FEED CAM 5	上下送りカム5	(1)
39		SS-8151150-TP	SCREW 15/64-28 L=10.5	止めねじ 15/64-28 L=10.5	(2)
40		400-53720	FEED DRIVING BASE ARM ASM.	上下送り台腕 (組)	1
41		400-26287	FEED DRIVING BASE ARM	上下送り台腕	(1)
42		SM-4040655-SP	SCREW M4 L=6	なべ小ねじ M4 L=6	(1)
43		400-26288	FEED DRIVING BASE SHAFT	上下送り台軸	1
44		400-86757	FEED DRIVING SHAFT	上下送り軸	1
45		400-86690	FEED_DRIVING_BEARING_SUPPORT	上下送り軸前ベアリング受け	1
46		SS-8661012-TP	SCREW	止めねじ	2
47		236-18101	FEED DRIVING CAM THRUST BUSH	上下送りカムスラストブッシュ	2
48	#05	SB-3200006-0A	BEARING	ころがり軸受	1
49	#05	SB-3200006-0B	BEARING	ころがり軸受	1
50	#05	SB-3200006-0C	BEARING	ころがり軸受	1
51		SB-1170012-00	BEARING	ころがり軸受	1
52		236-18309	FEED DRIVING CAM PLATE	上下送りカム蓋	1
53		SS-6090670-TP	SCREW 9/64-40 L=6	平ねじ 9/64-40 L=6	2
54		236-20503	GEAR,LARGE	変速歯車 (大)	1
55		SS-8661012-TP	SCREW	止めねじ	2
56		236-20008	HOOK SHAFT	釜軸	1
57		236-20156	HOOK SHAFT METAL COMPL	釜軸前メタル (結合)	1
58		236-20206	OIL SEAL	釜軸前オイルシール	2
59		229-16555	OIL SEAL SCREW ASM	下軸前止めねじ (組)	1
60		229-16506	SET SCREW	下軸前止めねじ	(1)
61		110-15906	OIL WICK	下軸前止めねじ油芯	(1)
62	#05	236-20701	GEAR,SMALL(A)	変速歯車 (小) A	1
63	#05	236-20800	GEAR,SMALL(B)	変速歯車 (小) B	1
64	#05	236-20909	GEAR,SMALL(C)	変速歯車 (小) C	1
65	#05	236-21006	GEAR,SMALL(D)	変速歯車 (小) D	1
66		SS-8661012-TP	SCREW	止めねじ	2
67	☆	D1837-555-BAA-A	BOBBIN CASE ASM	ボビンケース 組	1
68	☆	#03 111-41355	HOOK ASM	給油釜 組 C	1
69	☆	#04 110-38650	HOOK ASM	給油釜 組	1
70		400-86740	OIL SEAL	水平送り軸オイルシール	1
71		400-30786	FEED BASE COMPL.	送り台 (結合)	1
72	☆	* 400-91141	BOBBIN	ボビン	1
73		400-86744	HOOK DRIVING SHAFT OIL SEAL	釜軸オイルシール	1
74		236-20404	HOOK SHAFT REAR METAL	釜軸後ろメタル	1
75		400-89607	INNER_HOOK HOLDER	中釜押え	1
76		SM-4051055-SP	SCREW	なべねじ	1
77		400-86618	FEED_SHAFT_REAR_METAL	水平送り軸後メタル	1
78		400-86741	OIL SEAL	上下送り軸前オイルシール	1
79		400-86742	OIL SEAL	上下送り軸後オイルシール	1
80		SB-1200026-00	BEARING	ころがり軸受	1
81		400-86730	UNDER_SPROCKET_ASM	下スプロケット組	1
82		SM-80608A2-TP	SCREWS L=8	六角穴付き止めねじ M6 L=8	(2)
83		RC-1200001-KP	C-SHAPED SNAP RING	C形止め輪	1
84	#06	110-79506	FRONT SCREW	下軸前止めねじ	1
85	#06	RO-0360802-00	RUBBER RING	Oリング	1

NOTE(注記)

#01...FOR AA,BB,GG
#02...FOR EE
#03...FOR BB
#04...FOR AA,EE,GG
#05...SELECTIVE PARTS
#06...OPTIONAL PARTS
AA, BB, GG 用
EE 用
BB 用
AA, EE, GG 用
選択部品
オプション部品

*ABOUT THE DESTINATION, THE SPREAD "HOW TO MAKE USE OF THIS PARTS LIST" PLEASE SEE.
仕向地については、見開きの (パーツリストご利用に際して) を参照して下さい。

7. THREAD TRIMMER COMPONENTS

糸切り装置関係

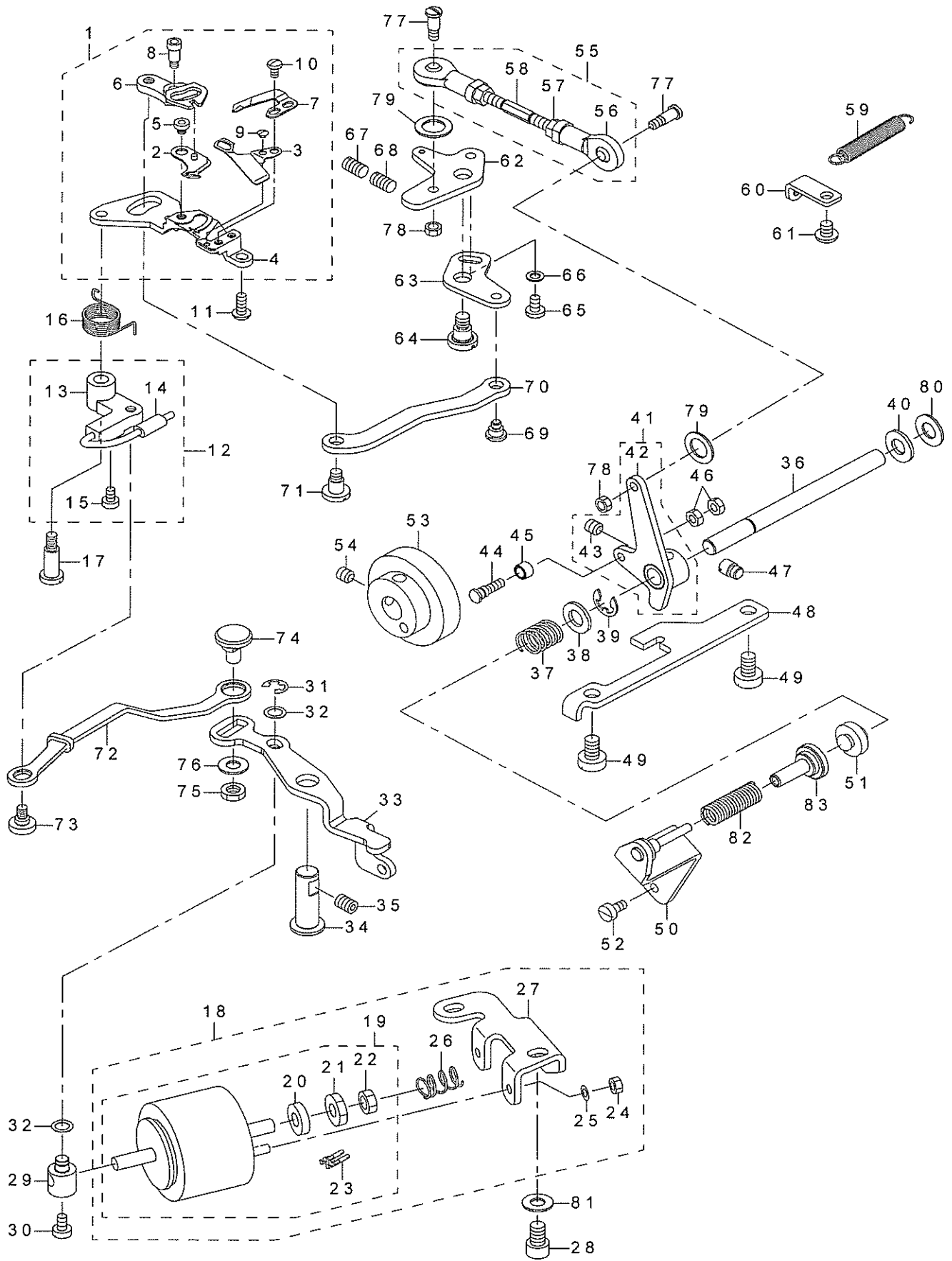

REF.NO	NOTE	PART NO	DESCRIPTION	品名	Qty
1		400-50585	KNIFE UNIT	メスユニット	1
2	☆	110-40052	MOVING KNIFE ASM.	動メス 組	(1)
3	☆	400-44189	THREAD_GUIDE_FOR_KNIFE	メス糸案内	(1)
4		229-47907	KNIFE MOUNTING BASE	メス取付け台	(1)
5		110-40409	MOVING KNIFE HINGE SCREW	動メス 段ねじ	(1)
6		229-48202	FORKED BASE FOR KNIFE	メス二股	(1)
7	☆	D2406-555-DOH	COUNTER KNIFE	固定メス	(1)
8		SD-0460703-TP	HINGE SCREW D=4.6 H=7	段ねじ D=4.6 H=7	(1)
9		SS-2060210-SP	SCREW 3/32-56 L=2.3	丸皿ねじ 3/32-56 L=2.3	(1)
10		SS-4080620-TP	SCREW 1/8-44 L=6	なべねじ 1/8-44 L=6	(2)
11		SM-4041055-SP	SCREW	なべねじ M4 L=10	1
12		400-36998	ASSY_PICKER_ARM	ピッカー腕(組)	1
13		400-61215	PICKER ARM	ピッカー腕	(1)
14	☆	400-36997	ASSY_PICKER	ピッカー組	(1)
15		SS-6090510-TP	SCREW 9/64-40 L=5.0	平ねじ 9/64-40 L=5	(2)
16		400-29398	PICKER SPRING	ピッカーばね	1
17		SD-0641456-TP	SHOULDER SCREW D=6.35 H=14.5	段ねじ D=6.35 H=14.5	1
18		400-86746	ASSY_THREAD_TRIM_SOLENOID	糸切りソレノイド(組)	1
19		400-89263	THREAD TRIMMER SOLENOID	糸切りソレノイド	(1)
20		110-43304	SOLENOID RUBBER	ソレノイド ゴム	(1)
21		NS-6660410-SH	NUT	六角ナット	(1)
22		NS-6660430-SP	NUT 1/4-40	六角ナット 1/4-40	(1)
23		HK-0346400-0B	PIN CONTACT	ピンコンタクト	(2)
24		NM-6040000-SN	NUT M4	六角ナット M4	(2)
25		WP-0430800-SC	WASHER M4	平座金小形丸 M4	(2)
26		400-89672	SPRING	糸切りソレノイド戻しばね	(1)
27		400-86727	SOLEOID INSTALLING BASE	糸切りソレノイド取付台	(1)
28	*	SM-6061002-TP	SCREW M6 L=10	六角穴ボルト M6 L=10	2
29		400-86711	SOLENOID_PIN	ソレノイドピン	1
30		SS-6110710-TP	SCREW 11/64-40 L=6.5	平ねじ 11/64-40 L=6.5	1
31		RE-0500000-KO	E-RING	E 形止め輪 5	1
32		106-18304	WASHER	ソレノイドピン座金	2
33		400-86634	CLUTCH_PLATE	クラッチ板	1
34		400-86635	CLUTCH_SHAFT	クラッチ軸	1
35		SM-8060812-TP	SCREW M6 L=8	止めねじ M6 L=8	1
36		400-86622	THREAD_TRIMMER_SHAFT	糸切り軸	1
37		312-56803	SPRING	押しボタンばね	1
38		WP-0841600-SD	WASHER M8	平座金小形丸 M8	1
39		RE-0700000-KO	E-RING 7	E 形止め輪 7	1
40		B1116-804-000	RUBBER WASHER	糸切りストッパー受けゴム座金	1
41	*	400-95843	ASSY CAM FOLLOWER	カム従動子(組)	1
42		400-86624	CAM_FOLLOWER_ASM	カム従動子組	(1)
43		SM-80606A2-TP	SCREW M6 L=6	六角穴付き止めねじ M6 L=6	(2)
44		400-86748	ROLLER SHAFT	コロ軸	1
45		400-15671	CAM_ROLLER	カムローラー	1
46		NM-6040001-SP	NUT M4X0.7	六角ナット M4 X 0.7 1種	2
47		400-86623	STOPPER_SCREW	ストッパーねじ	1
48		400-86636	CAM_FOLLOWER_STOPPER	カム従動子ストッパー	1
49	*	SM-6061010-TP	SCREW M6 L=10	平小ねじ M6 L=10	2
50	*	400-95870	THREAD TRIMMER STOPPER ASM.	糸切りストッパー組	1
51		B1116-210-000	STOPPER RUBBER	ストッパーゴム	1
52		SM-6040800-SP	SCREW	平ねじ	2
53		400-86747	THREAD TRIMMER CAM	糸切りカム	1
54		SM-80608A2-TP	SCREW M6 L=8	六角穴付き止めねじ M6 L=8	2
55		400-85708	CONNECTING_ROD_ASM.	糸切り連結ロッド組	1
56		400-85710	ROD_END	ロッドエンド	(2)
57		NM-6050001-SC	NUT M5	六角ナット M5 X 0.8 1種	(2)
58		400-86709	CONNECTING_BAR	連結棒	(1)
59		262-26209	SPRING	糸切りリンク戻しばね	1
60		400-86621	SPRING_RACK	糸切りリンクばね掛け	1
61		SM-4050655-SP	SCREW M5 L=6	なべ小ねじ M5 L=6	1
62		400-86631	THREAD_TRIMMER_LINK_A	糸切りリンク A	1
63		400-86632	THREAD_TRIMMER_LINK_B	糸切りリンク B	1
64		400-86633	SHOULDER_SCREW	糸切りリンク段ねじ	1
65		SS-7110740-TP	SCREW 11/64-40 L=7	丸平ねじ 11/64-40 L=7	1
66		WP-0450801-SP	WASHER	平座金	1
67		SM-8061050-TP	SCREW	止めねじ M6 L=10	1
68		SM-8061010-TP	SCREW	止めねじ M6 L=10	1
69		SD-0640321-SP	HINGE SCREW D=6.35 H=3.2	段ねじ D=6.35 H=3.2	1
70		400-86628	MOVING_KNIFE_LINK	動メスリンク	1
71		SD-0640631-TP	HINGE SCREW D=6.35 H=6.3	段ねじ D=6.35 H=6.3	1
72		400-86637	PICKER_LINK_ASM	ピッカーリンク組	1
73		SD-0630275-SP	HINGE SCREW D=6.35 H=2.7	段ねじ D=6.35 H=2.7	1
74		229-50000	PICKER LINK PIN	ピッカーリンクピン	1
75		NS-6150310-SP	NUT 15/64-28	六角ナット 15/64-28	1
76		WP-0621016-SH	WASHER	平座金	1
77		SD-0500701-TP	SHOULDER SCREW	段ねじ D=5 H=7	2
78		NS-6110310-SP	NUT 11/64-40	六角ナット 11/64-40	2
79		400-86712	CONNECTING ROD FELT	連結ロッドフェルト	2
80		B1223-771-000	NEEDLE ROD CRANK WASHER	糸切りストッパー受	1
81	*	WP-0621016-SD	WASHER 6.2X13X1	平座金 6.2 X 13 X 1	2
82	*	400-95218	THREAD TRIMMER STOPPER SPRING	糸切りストッパーばね	1
83	*	400-95873	THREAD TRIMMER STOPPER BUSH	糸切りストッパーブッシュ	1

8. OIL LUBRICATION COMPONENTS

給油関係

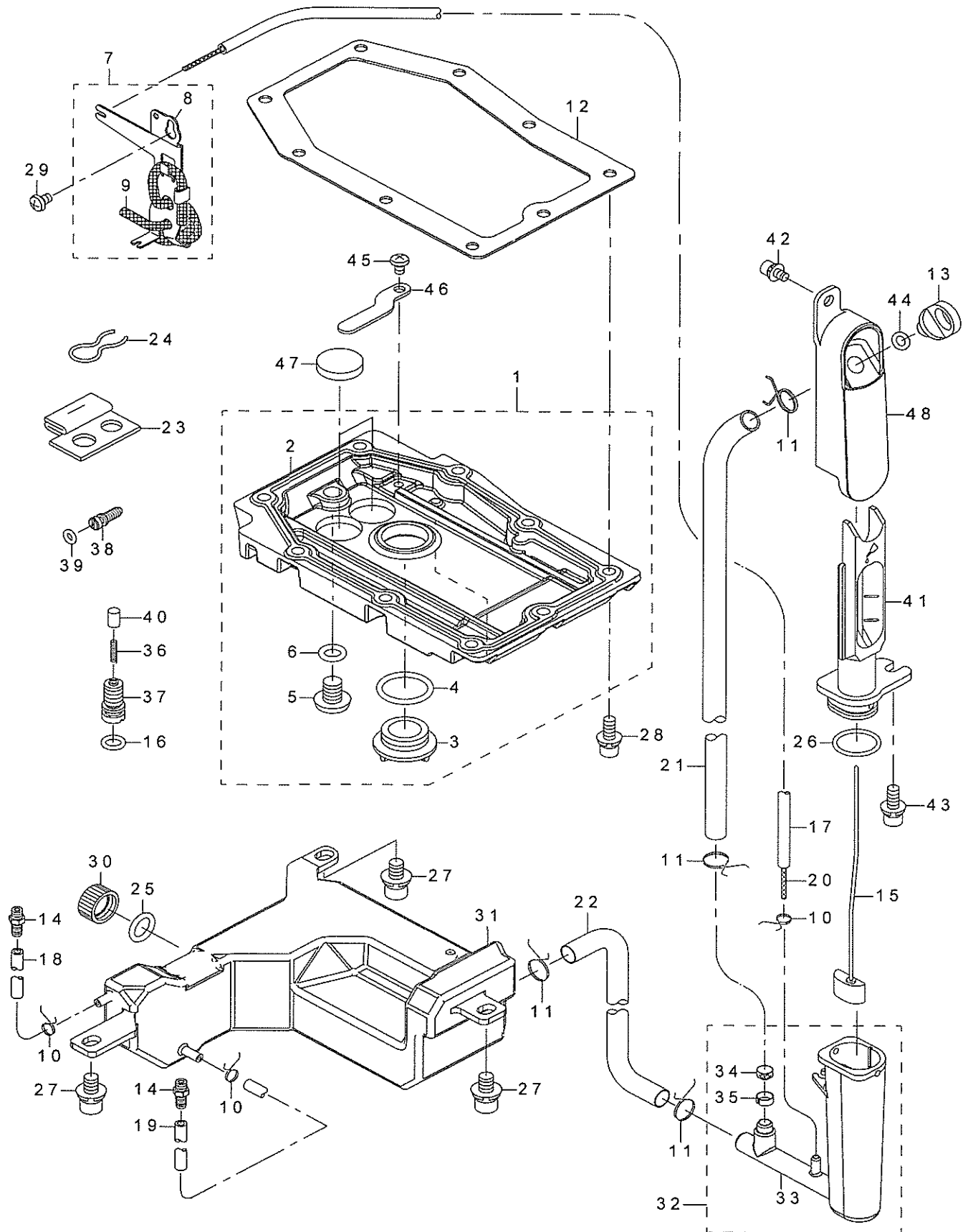

REF.NO	NOTE	PART NO	DESCRIPTION	品名	Qty
1		400-82059	GEAR BOX COVER ASM.	ギヤボックス蓋 (組)	1
2		400-82060	GEAR BOX COVER	ギヤボックス蓋	(1)
3		400-34246	OIL_SIGHT_WINDOW	油覗き窓	(1)
4		RO-1952401-00	RUBBER RING	O リング	(1)
5		131-71004	DRAIN SCREW	廃油ねじ	(1)
6		131-70105	RUBBER RING	O リング	(1)
7		236-29256	OIL WICK SUPPORT ASM.	油芯支え (組)	1
8		236-29207	OIL WICK SUPPORT	油芯支え	(1)
9		CQ-2500000-01	OIL WICK	油芯	(0.25)
10		236-29306	PIPE STOPPER A	パイプ止め A	3
11		236-29405	PIPE STOPPER B	パイプ止め B	4
12		400-37166	GEAR BOX PACKING	ギヤボックスパッキン	1
13		400-00344	LUBRICATING INLET CAP	給油口キャップ	1
14		SQ-2050453-MZ	CONNECTING SCREW	パイプ連結ねじ	2
15		400-86648	FLOATER_ASM	浮き子組	1
16		RO-0681901-00	RUBBER RING	O リング	1
17		236-30007	TUBE	チューブ	0.57
18		236-30007	TUBE	チューブ	0.08
19		236-30007	TUBE	チューブ	0.11
20		CQ-2000000-01	OIL WICK	油芯	0.75
21		236-30106	TUBE B	チューブ B	0.165
22		236-30106	TUBE B	チューブ B	0.2
23		400-75404	FACE FELT ASM.	面部フェルト (組)	1
24		229-25101	OIL FELT PRESSER	還流フェルト押え	1
25		RO-0982401-00	RUBBER RING	O リング	1
26		RO-1721801-00	RUBBER RING	O リング	1
27		SL-6061292-TN	SCREW	座金付き六角穴ボルト	3
28		SL-6051492-TN	BOLT	座金付き六角穴ボルト	9
29		SM-5040655-SN	SCREW	バインドねじ	1
30		400-13595	OIL_EXIT_CAP	廃油キャップ	1
31		400-86749	OIL_TANK	オイルタンク	1
32		400-86646	FLOATER_CASE_ASM.	浮き子ケース組	1
33		400-86647	FLOATER_CASE	浮き子ケース	(1)
34		236-30403	OIL FILTER	オイルフィルター	(1)
35		236-30502	OIL FILTER STOPPER	オイルフィルター止め	(1)
36		236-28902	PLUNGER SPRING	プランジャーばね	1
37		400-38328	PLUNGER SCREW	プランジャーねじ	1
38		400-37502	OIL ADJUSTING SCREW	油量調節ねじ	1
39		RO-0371801-00	RUBBER RING	O リング	1
40		236-28803	PLUNGER	プランジャー	1
41		400-86693	FROATER_CASE_GUIDE	浮き子ケースガイド	1
42		SL-6040892-TN	BOLT	座金付き六角穴ボルト	1
43		SL-6051492-TN	BOLT	座金付き六角穴ボルト	1
44		RO-0481901-00	RUBBER RING	O リング	1
45		SM-4040601-SC	SCREW M4X0.7 L=6	なべ小ねじ M 4 X 0. 7 L = 6	1
46		400-82061	MAGNET HOLDER	磁石押え	1
47		B8228-125-000	OIL RESERVOIR MAGNET	磁石	2
48		400-86697	FLOATER_SIGHT_WINDOW_B	浮き子指示窓 B	1

9. AUTOMATIC REVERSE FEED COMPONENTS

自動逆送り関係

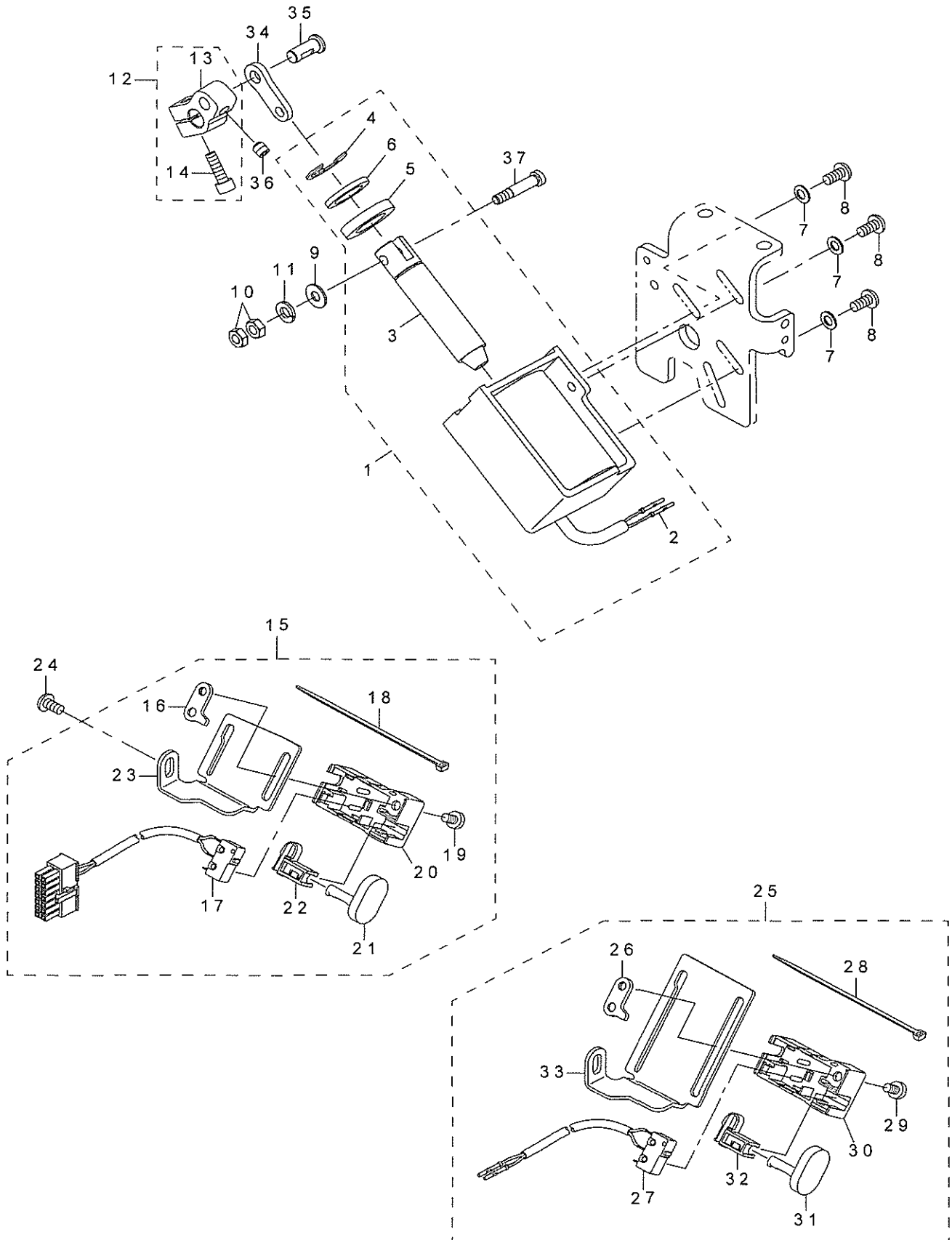

REF.NO	NOTE	PART NO	DESCRIPTION	品名	Qty
1		400-86750	REVERSE FEED SOLENOID ASM	逆送りソレノイド (組)	1
2		HK-0346400-0B	PIN CONTACT	ピンコンタクト	(2)
3		400-86753	REVERSE FEED SOLENOID PLUNGER	逆送りソレノイドプランジャー	(1)
4		RE-1200000-K0	E-RING 12	E 形止め輪 12	(1)
5		D2468-555-B00	RUBBER PLUNGER	プランジャーゴム	(1)
6		WP-1602616-SZ	WASHER 16X24X2.6	平座金 16 X 24 X 2.6	(1)
7		WP-0550800-SP	WASHER 5.5X10X0.8	平座金 5.5 X 10 X 0.8	3
8		SM-4051055-SP	SCREW	なべねじ	3
9		WP-0551016-SH	WASHER 5.5X13X1	平座金 5.5 X 13 X 1	1
10		NM-6050001-SP	NUT M5	六角ナット M5 X 0.8 1種	2
11		WS-0610002-KN	SPRING WASHER 6.1X12.2X1.5	ばね座金 M6	1
12	*	400-95844	REVERSE FEED ARM ASM.	逆送り腕 (組)	1
13		400-86698	REVERSE_FEED_ARM	逆送りソレノイド腕	(1)
14		SM-6051602-TP	SCREW M5X0.8 L=16	六角穴ボルト M5 X 0.8 L=16	(1)
15		236-31757	REVERSE FEED SWITCH ASM.	逆送りスイッチ (組)	1
16		236-32102	REVERSE FEED SWITCH BASE GUIDE	逆送りスイッチ台ガイド	(1)
17		236-32359	REVERSE FEED CORD ASM.	逆送りリコード A (組)	(1)
18		EA-9500B01-00	CABLE BAND	束線バンド	(1)
19		SS-7110740-TP	SCREW 11/64-40 L=7	丸平ねじ 11/64-40 L=7	(1)
20		236-31708	REVERSE FEED SWITCH COVER	逆送りスイッチカバー	(1)
21		236-31807	REVERSE FEED SWITCH SHAFT	逆送りスイッチ軸	(1)
22		236-31906	REVERSE FEED SWITCH SUPPORT	逆送りスイッチ受	(1)
23		236-32003	REVERSE FEED SWITCH BASE	逆送りスイッチ台	(1)
24		SM-4051055-SP	SCREW	なべねじ	1
25	#01	236-32656	OPTION SWITCH ASM.	オプションスイッチ (組)	1
26		236-32102	REVERSE FEED SWITCH BASE GUIDE	逆送りスイッチ台ガイド	(1)
27		236-32250	REVERSE FEED CORD ASM.	逆送りリコード (組)	(1)
28		EA-9500B01-00	CABLE BAND	束線バンド	(1)
29		SS-7110740-TP	SCREW 11/64-40 L=7	丸平ねじ 11/64-40 L=7	(1)
30		236-31708	REVERSE FEED SWITCH COVER	逆送りスイッチカバー	(1)
31		236-31807	REVERSE FEED SWITCH SHAFT	逆送りスイッチ軸	(1)
32		236-31906	REVERSE FEED SWITCH SUPPORT	逆送りスイッチ受	(1)
33		236-32607	OPTION SWITCH BASE	オプションスイッチ台	(1)
34		400-86655	REVERSE_FEED_CONNECTION_LINK	逆送りソレノイドリンク	1
35		400-86699	REVERSE_FEED_LINK_PIN	逆送りリンクピン	1
36		SM-8480652-TP	SCREW	止めねじ M6 X 0.75 L=6	1
37		400-86759	BACK_SOLENOID_PLUNGER_PIN	逆送りソレノイドプランジャーピン	1
		NOTE(注記)	#01...OPTIONAL PARTS	オプション部品	

10. WIPER COMPONENTS (FOR DDL-9000B-**-WB)

ワイパー関係 (DDL-9000B-**-WB用)

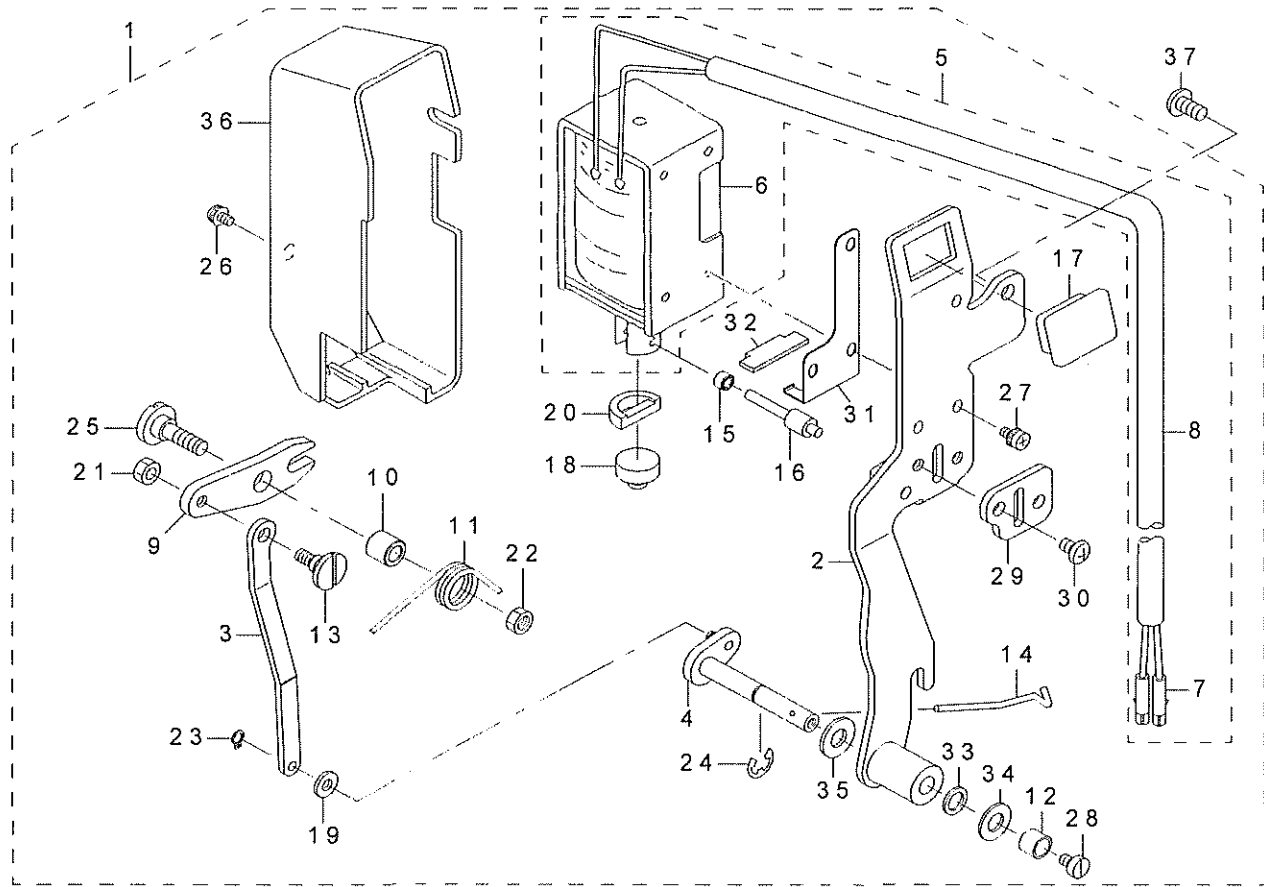

REF.NO	NOTE	PART NO	DESCRIPTION	品名	Qty
1		400-86676	WIPER ASM.	ワイパー (組)	1
2		400-77853	WIPER BASE ASM.	ワイパー台 (組)	(1)
3		400-86723	WIPER LINK B	ワイパーリンク B	(1)
4		400-86724	WIPER SHAFT ASM.	ワイパー軸 (組)	(1)
5	*	400-95175	WIPER_SOLENOID_ASM.	ワイパーソレノイド組	(1)
6		400-89264	WIPER SOLENOID	ワイパーソレノイド	(1)
7		HK-0346400-0B	PIN CONTACT	ピンコンタクト	(2)
8		HW-5000700-00	2-CORE CABTYRE CORD	2芯キャブタイヤコード	(1, 3)
9		229-56106	WIPER LINK A	ワイパーリンク A	(1)
10		229-56205	WIPER HINGE SCREW COLLAR	ワイパー段ねじカラー	(1)
11		229-56304	WIPER SPRING	ワイパーばね	(1)
12		229-56809	WIPER COLLAR	ワイパーカラー	(1)
13		229-56908	WIPER LINK B HINGE SCREW	ワイパーリンク B 段ねじ	(1)
14		229-57005	WIPER	ワイパー	(1)
15		229-57203	WIPER LINK COLLAR	ワイパーリンクカラー	(1)
16		400-77852	WIPER SOLENOID SHAFT	ワイパーソレノイド軸	(1)
17		400-86678	WIPER_SW_RUBBER	ワイパー SW キャップ	(1)
18		229-55900	WIPER RUBBER A	ワイパーゴム A	(1)
19		400-86717	FELT_B	フェルト B	(1)
20		229-56007	WIPER RUBBER B	ワイパーゴム B	(1)
21		NS-6090310-SP	NUT 9/64-40	六角ナット 9/64-40	(1)
22		NS-6110310-SP	NUT 11/64-40	六角ナット 11/64-40	(1)
23		RC-0370411-KP	RETAINING RING	C 形止め輪	(1)
24		RE-0500000-K0	E-RING	E 形止め輪 5	(1)
25		SD-0650321-TP	HINGE SCREW D=6.5 H=3.2	段ねじ D=6.5 H=3.2	(1)
26		SL-4030631-SC	SCREW M3X6	座金付きなべ小ねじ M3 L=6	(1)
27		SL-4030641-SE	SCREW	座金付きねじ	(3)
28		SS-8090540-SP	SCREW 9/64-40 L=5.0	平ねじ 9/64-40 L=5	(1)
29		400-77851	WIPER SOLENOID SHAFT GUIDE	ワイパーソレノイド軸ガイド	(1)
30		SS-4110615-SP	SCREW 11/64-40 L=6	なべ小ねじ 11/64-40 L=6	(2)
31		400-86680	WIPER_STOPPER_RUBBER HOLDER	ワイパーSTOPPERゴム取付板	(1)
32		400-86679	WIPER_STOPPER_RUBBER	ワイパーSTOPPERゴム	(1)
33		WP-0661016-SP	WASHER	平座金	(1)
34		WP-0651001-SC	WASHER	平座金	(1)
35		400-86716	FELT_A	フェルト A	(1)
36		229-55504	WIPER COVER	ワイパーカバー	(1)
37		SM-4051055-SP	SCREW	なべねじ	1

11. THREAD STAND COMPONENTS

糸立装置関係

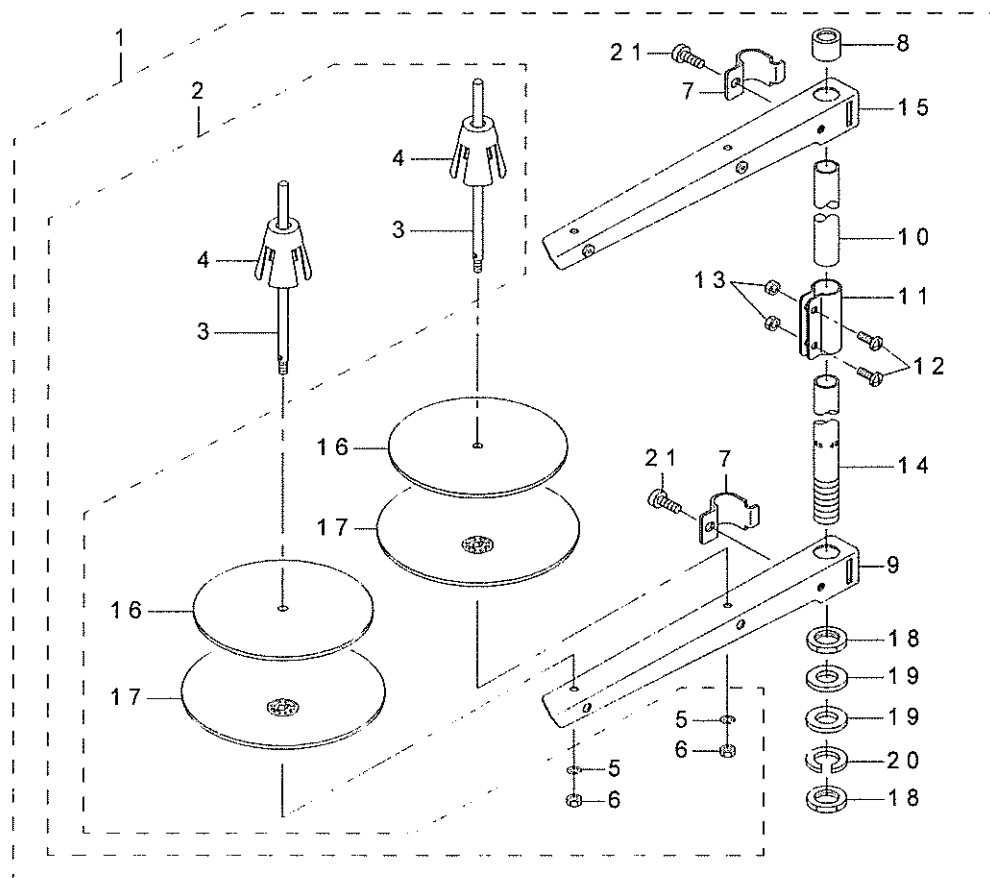

REF.NO	NOTE	PART NO	DESCRIPTION	品名	Qty
1		229-30358	THREAD STAND ASM.	糸立装置 (組)	1
2		400-62684	SPOOL PIN ASM.	糸巻受棒 (組)	(1)
3		229-31000	SPOOL PIN	糸巻き受け棒	(2)
4		229-31109	SPOOL RETAINER	糸巻き振れ止め	(2)
5		WS-0510002-KN	SPRING WASHER	ばね座金 5.1 X 9.2 X 1.3	(2)
6		NM-6050001-SE	NUT M5	六角ナット M5	(2)
7		229-30705	THREAD GUIDE ARM JOINT	糸立棒締め金具	(2)
8		229-31406	SPOOL REST ROD RUBBER CAP	糸立棒保護ゴム	(1)
9		229-30507	SPOOL REST ARM	糸立腕	(1)
10		229-30408	SPOOL REST ROD, UPPER	糸立棒 (上)	(1)
11		229-31307	SPOOL REST ROD JOINT	糸立棒継手	(1)
12		SM-4051405-SE	SCREW M5 L=14	なべ小ねじ M5 L=14	(2)
13		NM-6050001-SE	NUT M5	六角ナット M5	(2)
14		229-30309	SPOOL REST ROD, LOWER	糸立棒 (下)	(1)
15		229-30556	THREAD STANDING ARM ASM.	糸立腕 (組)	(1)
16		229-30903	SPOOL REST CUSHION	糸巻き受け皿クッション	(2)
17		229-30804	SPOOL REST	糸巻き受け皿	(2)
18		NM-6160511-SE	NUT M16X1.5	六角ナット M16 X 1.5 1種	(2)
19		WP-1612616-SE	WASHER 16X30X2.6	平座金	(2)
20		WS-1643202-KR	SPRING WASHER	ばね座金 16.4 X 26.6 X 3.2	(1)
21		SM-6061610-SC	SCREW M6 L=16	平小ねじ M6 L=16	(2)

12. UNDER COVER COMPONENTS

アンダーカバー関係

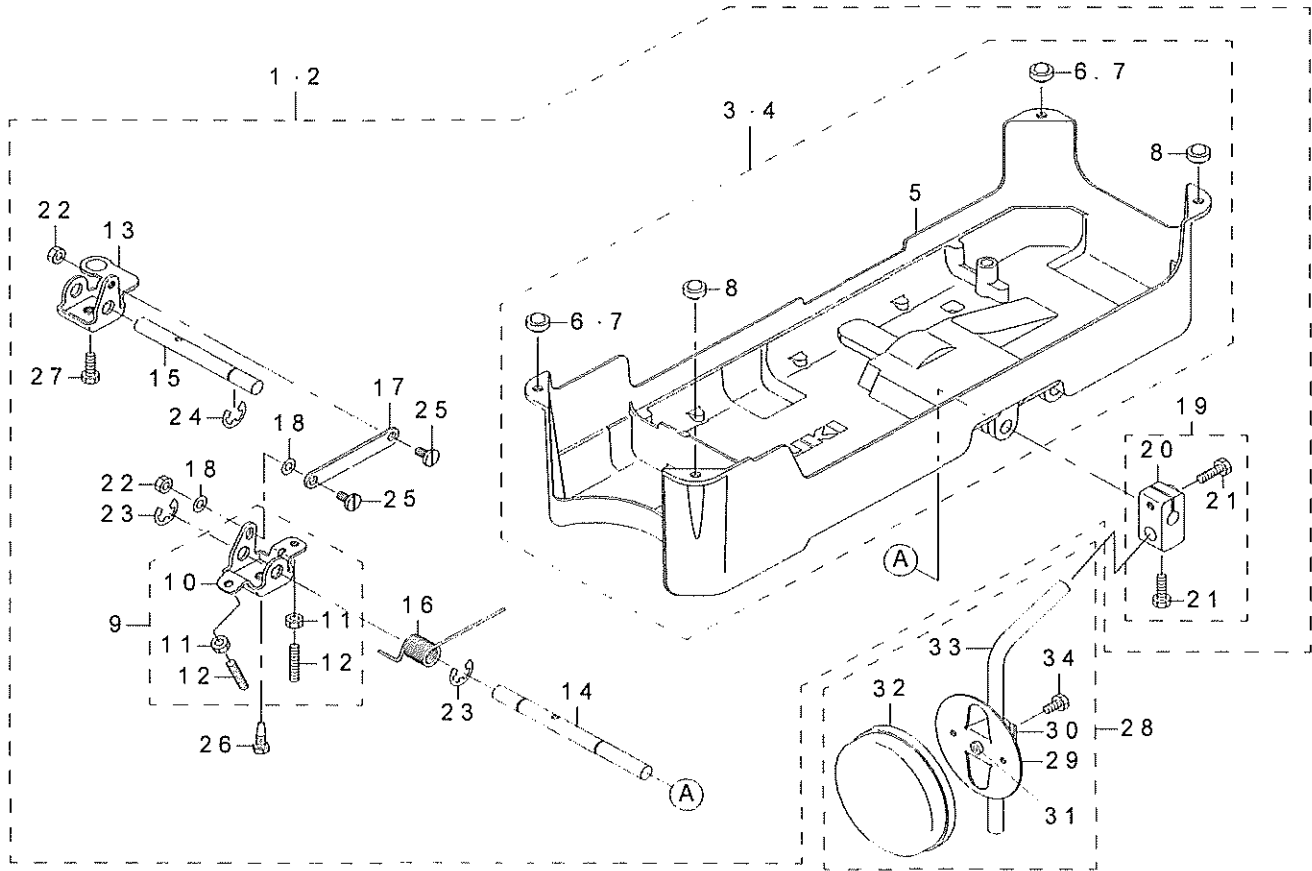

REF.NO	NOTE	PART NO	DESCRIPTION	品名	Qty
1	#01	400-89665	UNDER COVER AH ASM.	アンダーカバー AH (組)	1
2	#02	400-62321	UNDER COVER A ASM.	アンダーカバー A 組	1
3	#01	400-89671	UNDER COVER BH ASM.	アンダーカバー BH (組)	(1)
4	#02	400-62323	UNDER COVER B ASM.	アンダーカバー B 組	(1)
5		236-39008	UNDER COVER	アンダーカバー	(1)
6	* #01	229-32008	RUBBER CUSHION	頭部支えゴム	(2)
7	#02	B1116-210-D00	FRAME SUPPORT RUBBER	頭部支えゴム	(2)
8		B1116-210-D00	FRAME SUPPORT RUBBER	頭部支えゴム	(2)
9		236-39156	BRACKET ASM.	膝上げ回転腕 (組)	(1)
10		236-39107	BRACKET	膝上げ回転腕	(1)
11		NM-6060001-SE	NUT M6	六角ナット M6 1種	(2)
12		SM-8063012-TR	SCREW M6 L=30	止めねじ	(2)
13		236-39206	CONNECTING ROD	膝上げ差動腕	(1)
14		236-39305	KNEE PRESS ROD	膝当て横軸	(1)
15		236-39404	SHAFT	膝上げ差動軸	(1)
16		236-39503	SPRING	膝上げ回転腕ばね	(1)
17		236-39602	CONNECTING ROD	膝上げ連結ロッド	(1)
18		WP-0650876-SD	WASHER 6.5X13X0.8	平座金 6.5 X 13 X 0.8	(2)
19		229-32453	BRACKET ASM.	膝当て縦軸取付け腕 (組)	(1)
20		229-32404	BRACKET	膝当て縦軸取付け腕	(1)
21		SM-9062053-SR	SCREW M6 L=20	六角ボルト	(2)
22		NS-6150310-SP	NUT 15/64-28	六角ナット 15/64-28	(2)
23		RE-1000000-K0	E-RING 10	E 形止め輪 10	(2)
24		RE-1000000-K0	E-RING 10	E 形止め輪 10	(1)
25		SD-0720331-SP	HINGE SCREW D=7.24 H=3.3	段ねじ D=7.24 H=3.3	(2)
26		SM-9061853-SR	SCREW M6 L=17.5	六角ボルト	(1)
27		SM-9061853-SR	SCREW M6 L=17.5	六角ボルト	(1)
28		229-34251	KNEE PAD PLATE ASM.	膝当て板 (組)	1
29		229-34202	KNEE PAD PLATE	膝当て板	(1)
30		229-34301	KNEE PAD PLATE SUPPORT	膝当て板支え	(1)
31		229-34400	KNEE PAD PLATE RUBBER	膝当て板ゴム	(1)
32		229-34509	KNEE PAD PLATE COVER	膝当て板カバー	(1)
33		229-34608	KNEE PAD UPRIGHT SHAFT	膝当て縦軸	(1)
34		SM-9061203-SE	SCREW M6 L=12	六角ボルト M6 L=12	(1)

NOTE(注記)

#01.....FOR DDL-9000B-SH
#02.....EXCEPT DDL-9000B-SH

DDL-9000B-SH
DDL-9000B-SHを除く

13. ACCESSORIE PART COMPONENTS

付属品関係

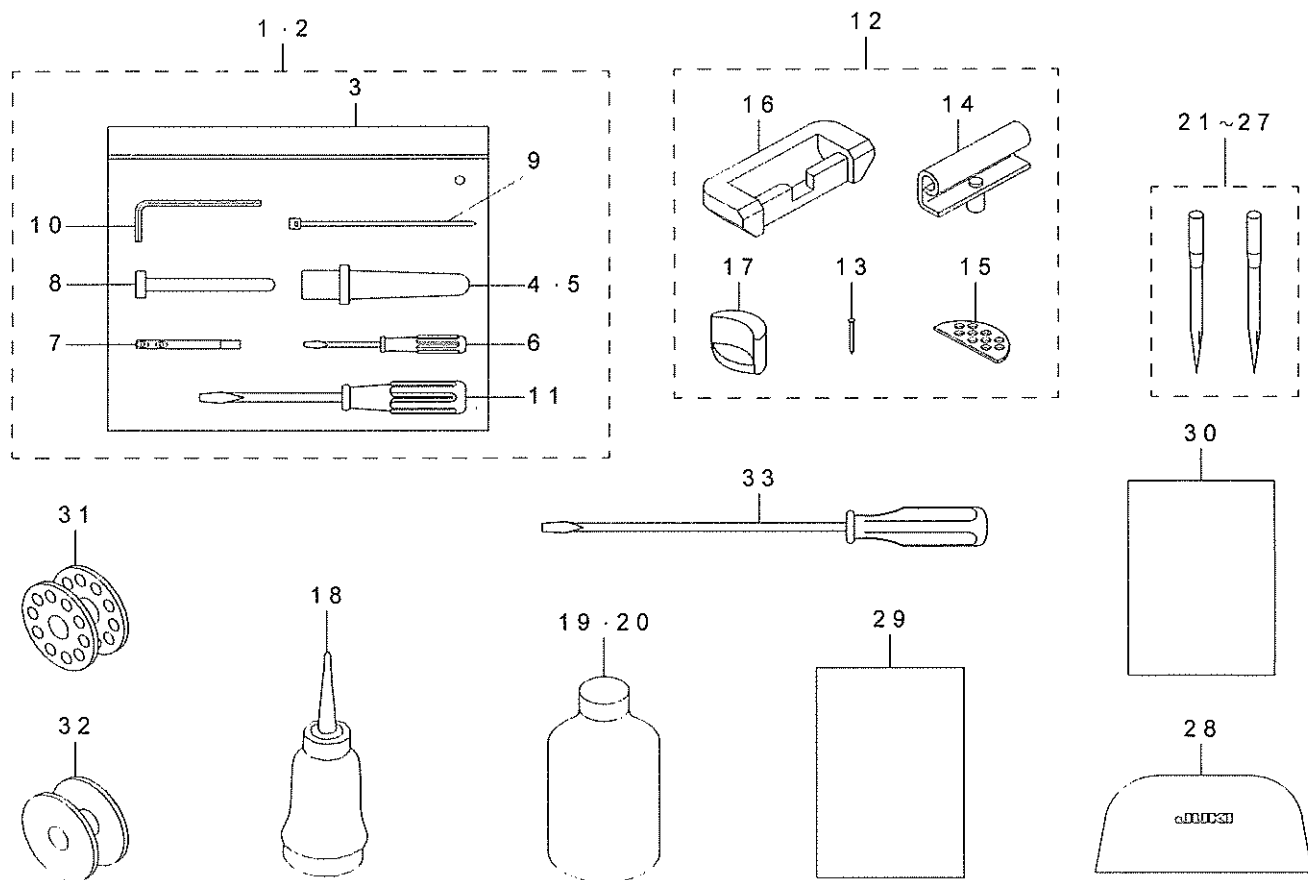

REF.NO	NOTE	PART NO	DESCRIPTION	品名	Qty
1	#02	400-89663	ACCESSORIE BAG ASM.	付属品バック (組)	1
2	#01	400-91140	ACCESSORIE BAG AK ASM.	付属品バック AK (組)	1
3		229-32800	ACCESSORIE BAG	付属品バッグ	(1)
4	#02	229-31604	FRAME SUPPORT BAR	頭部支え棒	(1)
5	#01	400-24081	HEAD SUPPORT ROD	頭部支え棒	(1)
6		229-33204	SCREW DRIVER, SMALL	ドライバー (小)	(1)
7		225-02504	THREAD GUIDE BAR	糸案内棒	(1)
8		236-39701	KNEE LIFTER PRESSER ROD	膝上げ押し棒	(1)
9		HX-0004300-00	CLIP	結束バンド	(1)
10		400-55591	HEXAGONAL WRENCH KYE	六角棒スバナ 3 mm	(1)
11		229-33105	SCREW DRIVER, MIDDLE	ドライバー (中)	(1)
12		229-58052	RUBBER HINGE ASM.	ラバーヒンジ (組)	1
13		229-26208	NAIL	ゴムヒンジ座打ち釘	(8)
14		229-26356	HINGE COMPL.	ヒンジ結合	(2)
15		229-26505	WASHER	頭部クッション座	(2)
16		229-26000	RUBBER CUSHION	ゴムヒンジ座	(2)
17		229-58003	FRAME BUBBER CUSHION	頭部支えゴム座	(2)
18		B9121-012-0A0	OILER ASM.	油差し組	1
19	#03	MDF-RX1600C0	DEFRIX OIL NO.1(600CC)	デフレックスオイル NO. 1 (600 CC)	1
20	#03	MML-007600CA	JUKI MACHINE OIL 7	JUKI MACHINE OIL 7	1
21	#03	MDB-100B1100	NEEDLE DBX1 #11	針 DBX 1 #11	1
22	#03	MDB-100B0900	NEEDLE DBX1 #9	針 DBX 1 #9	1
23	#03	MDB-100B2100	NEEDLE DBX1 #21	針 DBX 1 #21	1
24	#03	MDB-100B1400	NEEDLE DBX1 #14	針 DBX 1 #14	1
25	#03	MC-2005013-00	NEEDLE 134 NM130	針 134 130	1
26	#03	MC-2005006-50	NEEDLE 134 NM65	針 シュメツ 134 NM65	1
27	#03	MC-2005007-50	NEEDLE 134 NM75	針 シュメツ 134 NM75	1
28		400-70090	HEAD COVER	頭部カバー	1
29		400-89323	DDL-9000B SETUP DOCUMENT	DDL-9000B セットアップ注意シート	1
30	#03	CM-6001002-01	WEEE INFORMATION SHEET	WEEE インフォメーション シート	1
31	#03	B9117-012-000	BOBBIN	ボビン	1
32	* #03	400-91141	BOBBIN	ボビン	1
33		229-33006	SCREW DRIVER, LARGE	ドライバー (大)	1

NOTE(注記)

#01...TYPE AK
 #02...EXCEPT TYPE AK
 #03...VARIOUS NOS.FOR DESTINATIONS

AK仕様
 AK仕様は除く
 仕向地による

14. EXCLUSIVE PARTS DDL-9000B DS

DDL-9000B DS 専用部品

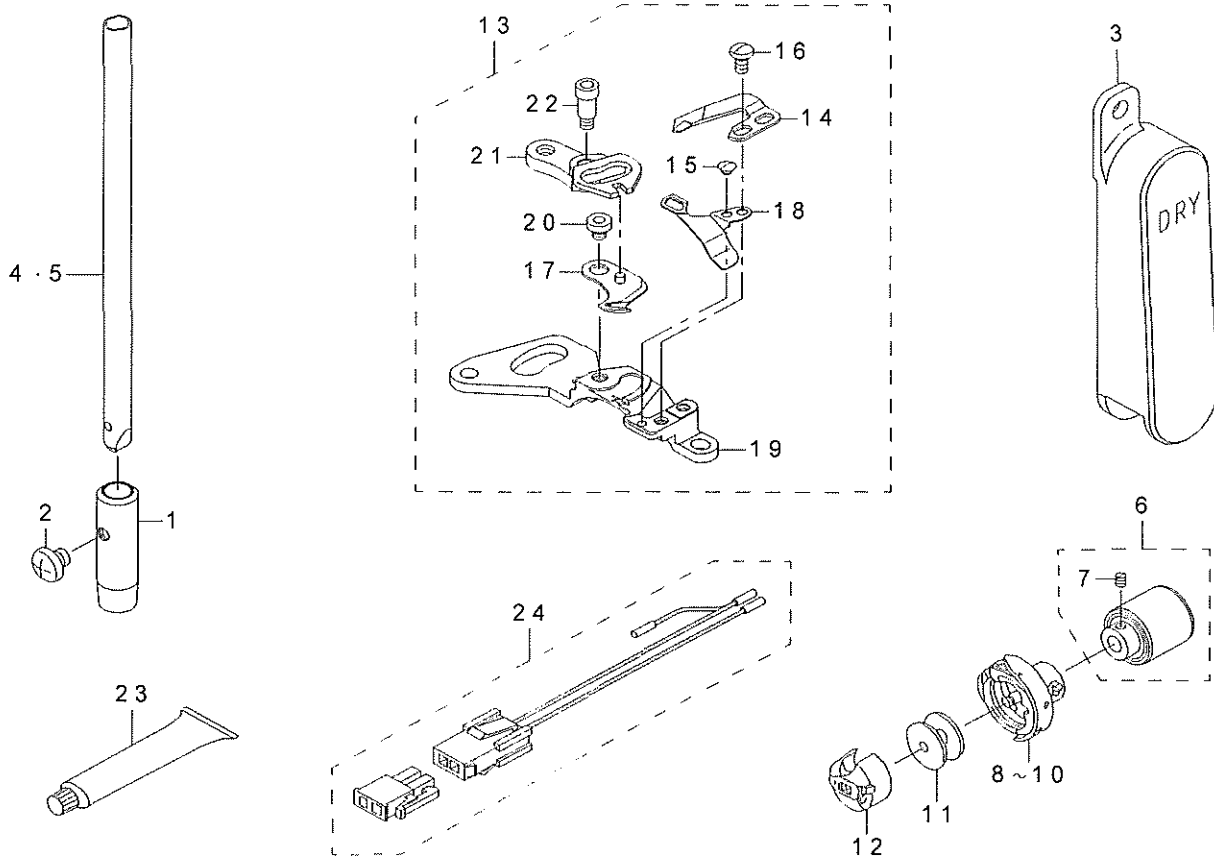

REF.NO	NOTE	PART NO	DESCRIPTION	品名	Qty
1		400-86605	NEEDLE_BAR_LOWER_METAL_MD	針棒下メタル_MD	1
2		SM-4050501-SC	SCREW M5X0.8 L=5	なべ小ねじ M5 X 0.8 L=5	1
3		400-37146	FLOATER SIGHT WINDOW D	浮き子指示窓 D	1
4	#02	400-86604	NEEDLE_BAR_D_(B)	針棒 D (B)	1
5	#05	400-86602	NEEDLE_BAR_D_(A)	針棒 D (A)	1
6		400-89274	HOOK_SHAFT_FRONT_BEARING_COMPL	釜軸前ヘアリング (結合)	1
7		SS-6110420-TP	SCREW 11/64-40 L=4.8	平ねじ 11/64-40 L=4.8	(2)
8	☆ #02	228-90404	RP HOOK C	RP 釜 C	1
9	☆ #03	228-90206	RP HOOK	RP 釜	1
10	☆ #01	228-90305	RP HOOK S	RP 釜 S	1
11	☆	400-91141	BOBBIN	ボビン	1
12	☆	228-96252	BOBBIN CASE ASM.	ボビンケース (組)	1
13		400-50586	KNIFE UNIT D	メスユニット D	1
14	☆	228-95908	COUNTER KNIFE	固定メス	(1)
15		SS-2060210-SP	SCREW 3/32-56 L=2.3	丸皿ねじ 3/32-56 L=2.3	(1)
16		SS-4080620-TP	SCREW 1/8-44 L=6	なべねじ 1/8-44 L=6	(2)
17	☆	110-40052	MOVING KNIFE ASM.	動メス組	(1)
18	☆	400-50588	THREAD GUIDE FOR KNIFE D	メス糸案内 D	(1)
19		229-47907	KNIFE MOUNTING BASE	メス取付け台	(1)
20		110-40409	MOVING KNIFE HINGE SCREW	動メス段ねじ	(1)
21		228-96005	FORKED BASE FOR KNIFE	メス二股	(1)
22		SD-0460703-TP	HINGE SCREW D=4.6 H=7	段ねじ D=4.6 H=7	(1)
23	#04	400-06323	JUKI GREASE A TUBE	ジューキグリース A チューブ	1
24		400-50581	JOINT_CABLE_ASM	中継ケーブル組	1

NOTE(注記)

#01...FOR DDL-9000B-DS AA DDL-9000B-DS AA 用
 #02...FOR DDL-9000B-DS BB DDL-9000B-DS BB 用
 #03...FOR DDL-9000B-DS EE,GG DDL-9000B-DS EE, GG 用
 #04...FOR OPTIONAL PARTS オプション部品
 #05...FOR DDL-9000B-DS AA,EE,GG DDL-9000B-DS AA, EE, GG 用

*ABOUT THE DESTINATION, THE SPREAD "HOW TO MAKE USE OF THIS PARTS LIST" PLEASE SEE.
 仕向地については、見開きの (パーツリストご利用に際して) を参照して下さい。

15. EXCLUSIVE PARTS DDL-9000B MS,MA
DDL-9000B MS, MA 専用部品

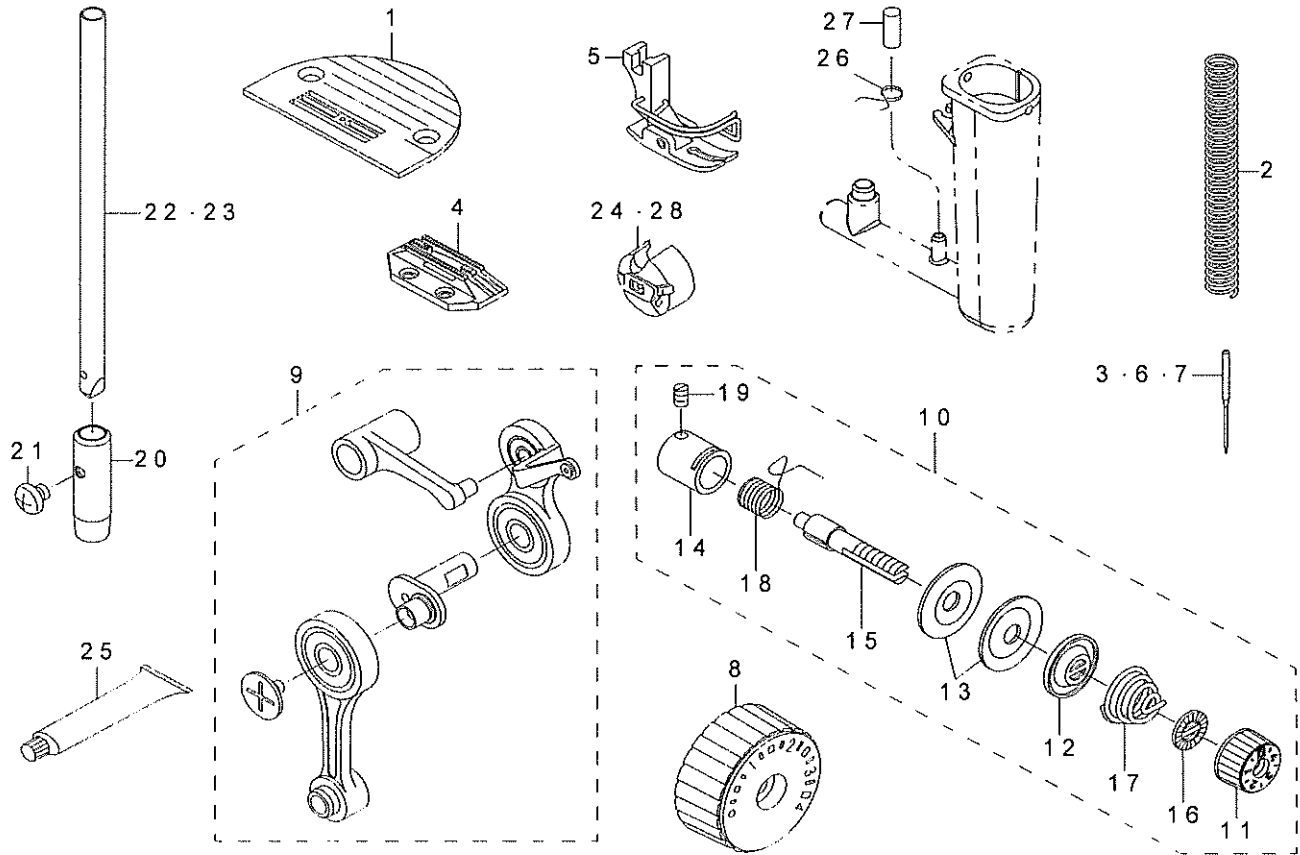

REF.NO	NOTE	PART NO	DESCRIPTION	品名	Qty
1	#05	110-01906	THROAT PLATE K	針板 K	1
2	#03	111-62104	SPRING	押え調節ばね	1
3	☆ #07	MDB-100B1100	NEEDLE DBX1 #11	針 DBX1 #11	1
4	#05	D1613-155-W00	FEED DOG W	送り歯 W	1
5	#06	D1524-555-DBB	PRESSER FOOT ASM.	従押し (組)	1
6	☆ #08	MDB-100B0900	NEEDLE DBX1 #9	針 DBX1 #9	1
7	☆ #04	MC-2005006-50	NEEDLE 134 NM65	針 シュメツツ 134 NM65	1
8	#03	400-50584	FEED DIAL 4	送りダイヤル 4	1
9	#03	400-37439	THREAD TAKE UP COMP.A	天秤 (結合) A	1
10	#03	400-37479	THREAD TENSION DISK ASM.A	糸調子 (組) A	1
11		236-26005	THREAD TENSION NUT	糸調子ナット	(1)
12		B3132-552-000	THREAD TENSION DISK PRESSER	糸調子皿押え	(1)
13		B3126-012-000	THREAD TENSION DISK	糸調子皿	(2)
14		400-24845	TENSION POST SOCKET ASM	糸調子棒台 (組)	(1)
15		B3115-552-000	TENSION POST	糸調子棒	(1)
16		B3120-125-000	ROTATING STOPPER	糸調子皿回転止め	(1)
17		D3129-555-D00	THREAD TENSION SPRING	糸調ばね	(1)
18	☆	D3128-555-D00	TAKE-UP SPRING	糸取りばね	(1)
19		SS-8090670-SP	SCREW 9/64-40 L=5.5	止めねじ 9/64-40 L=5.5	(1)
20		400-86605	NEEDLE_BAR_LOWER_METAL_MD	針棒下メタル_MD	1
21		SM-4050501-SC	SCREW M5X0.8L=5	なべ小ねじ M5X0.8 L=5	1
22	#09	400-86604	NEEDLE_BAR_D (B)	針棒 D (B)	1
23	#10	400-86602	NEEDLE_BAR_D (A)	針棒 D (A)	1
24	* #03	400-00264	BOBBIN CASE ASM.	ボビンケース (組)	1
25	#01	400-06323	JUKI GREASE A TUBE	JUKI グリース A チューブ	1
26		236-29306	PIPE STOPPER A	パイプ止め A	1
27		235-40305	FLOATER CASE CAP	浮き子ケースキャップ	1
28	* #02	D1837-555-BAA-A	BOBBIN CASE ASM.	ボビンケース組	1
		NOTE (注記)	#01...OPTIONAL PARTS #02...FOR DDL-9000B-MS #03...FOR DDL-9000B-MA #04...FOR DDL-9000B-MA BB #05...FOR DDL-9000B-MA EE #06...FOR DDL-9000B-MA AA, BB, EE #07...FOR DDL-9000B-MA GG #08...FOR DDL-9000B-MA AA, EE #09...FOR DDL-9000B-MS MA, BB #10...FOR DDL-9000B-MS MA, AA, EE, GG	オプション部品 DDL-9000B-MS 用 DDL-9000B-MA 用 DDL-9000B-MA BB 用 DDL-9000B-MA EE 用 DDL-9000B-MA AA, BB, EE 用 DDL-9000B-MA GG 用 DDL-9000B-MA AA, EE 用 DDL-9000B-MS MA, BB 用 DDL-9000B-MS MA, AA, EE, GG 用	

*ABOUT THE DESTINATION, THE SPREAD "HOW TO MAKE USE OF THIS PARTS LIST" PLEASE SEE.
仕向地については、見開きの (パーツリストご利用に際して) を参照して下さい。

16. EXCLUSIVE PARTS DDL-9000B SH
DDL-9000B SH 専用部品

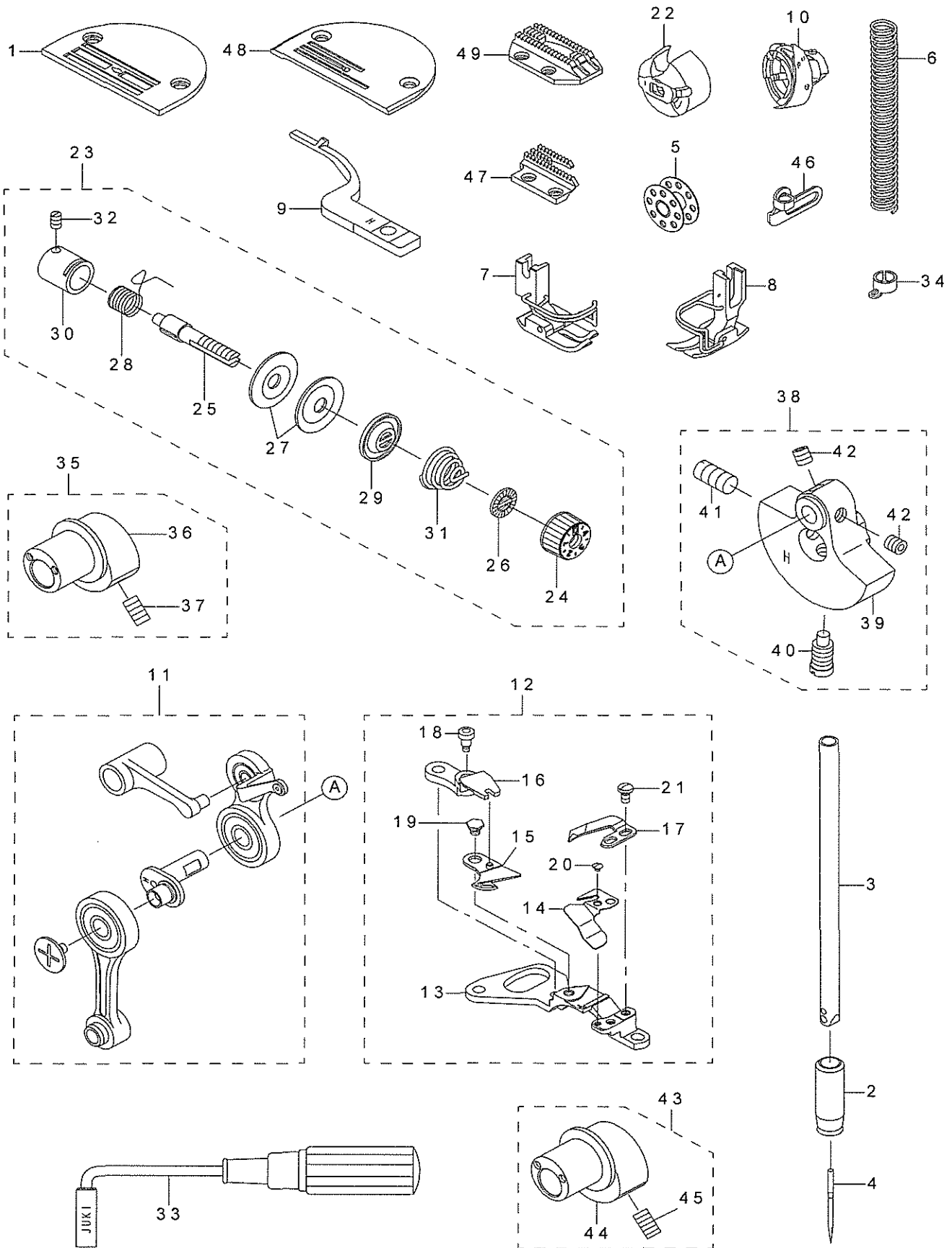

REF.NO	NOTE	PART NO	DESCRIPTION	品名	Qty
1	#01	400-89605	THROAT_PLATE_J	針板 J	1
2		236-45609	NEEDLE BAR METAL,LOWER H	針棒下メタル H	1
3		400-61767	NEEDLE BAR H	針棒 H	1
4 ☆	#03	MDB-100B2100	NEEDLE DBX1 #21	針 DBX 1 #21	1
5		B9117-012-000	BOBBIN	ボビン	1
6		B1505-552-000-A	PRESSER SPRING	押え調節ばね	1
7	#01	D1524-555-EBL	PRESSER FOOT ASM.	従押え組み (針ガード付き)	1
8		400-64839	PRESSER FOOT ASM	自由押え (組) 指ガード付き	1
9		400-89610	INNER_HOOK HOLDER_H	中金押え H	1
10 ☆		110-92251	LUBRICATING BOBBIN ASM.	給油釜組	1
11		400-55604	THREAD TAKE UP COMP.H	天祥結合 H	1
12		400-50587	KNIFE UNIT H	メスユニット H	1
13		110-95502	KNIFE MOUNT BASE	メス取付け台	(1)
14 ☆		400-44190	THREAD_GUIDE_FOR_KNIFE-H	メス糸案内 H	(1)
15 ☆		114-09257	MOVING KNIFE J ASM.	動メス J (組)	(1)
16		400-09894	FORKED BASE FOR KNIFE	メス二股	(1)
17 ☆		400-50589	FIX KNIFE H	固定メス H	(1)
18		SD-0460703-TP	HINGE SCREW D=4.6 H=7	段ねじ D=4.6 H=7	(1)
19		SD-0500131-TP	HINGE SCREW D=5 H=1.25	段ねじ D=5 H=1.25	(1)
20		SS-2060210-SP	SCREW 3/32-56 L=2.3	丸皿ねじ 3/32-56 L=2.3	(1)
21		SS-4080620-TP	SCREW 1/8-44 L=6	なべねじ 1/8-44 L=6	2
22 ☆		400-00264	BOBBIN CASE ASM.	ボビンケース組	1
23		400-37313	THREAD TENSION DISK ASM H	糸調子 (組) H	1
24		236-26005	THREAD TENSION NUT	糸調子ナット	(1)
25		B3115-552-000	TENSION POST	糸調子棒	(1)
26		B3120-125-000	ROTATING STOPPER	糸調子皿回転止め	(1)
27		B3126-012-000	THREAD TENSION DISK	糸調子皿	(2)
28 ☆		B3128-012-000	TAKE-UP SPRING	糸取りばね	(1)
29		B3132-552-000	THREAD TENSION DISK PRESSER	糸調子皿押え	(1)
30		400-24845	TENSION POST SOCKET ASM	糸調子棒台 (組)	(1)
31		B3114-232-000	THREAD TENSION SPRING	糸調子ばね	(1)
32		SS-8090670-SP	SCREW 9/64-40 L=5.5	止めねじ 9/64-40 L=5.5	(1)
33	#04	J1063-000-000	WRENCH	動メス用スパナ	1
34		400-24124	NEEDLE BAR THREAD GUIDE	針棒糸掛け	1
35		236-19059	VERTICAL FEED CAM H ASM.	上下送りカム (組) H	1
36		236-19000	VERTICAL FEED CAM H	上下送りカム H	(1)
37		SS-8151150-TP	SCREW 15/64-28 L=10.5	止めねじ 15/64-28 L=10.5	(2)
38		400-55058	ASSY COUNTER WEIGHT H	釣合錘 (組) H	1
39		400-53411	COUNTER WEIGHT H	釣合錘 H	(1)
40		400-04171	COUNTER_WEIGHT_SCREW	止めねじ	(1)
41		SM-8081652-TP	SCREW M8 L=16	止めねじ M8 L=16	(1)
42		SM-80606A2-TP	SCREW M6 L=6	六角穴付き止めねじ M6 L=6	(2)
43	#04	400-69369	VERTICAL FEED CAM ASM. 2.0	上下送りカム 2.0組	1
44		400-69370	VERTICAL FEED CAM 2.0	上下送りカム 2.0	(1)
45		SS-8151150-TP	SCREW 15/64-28 L=10.5	止めねじ 15/64-28 L=10.5	(2)
46		400-63697	ARM THREAD GUIDE A H	アーム糸案内 A H	1
47	#02	110-62601	FEED DOG	送り	1
48	#02	110-62007	THROAT PLATE, A	針板 A	1
49	#01	114-03003	FEED J	送り J	1

NOTE(注記)

#01....FOR AA,BB,EE
 #02....FOR GG
 #03....FOR AA,GG,EE
 #04....OPTIONAL PARTS

AA, BB, EE 用
 GG 用
 AA, GG, EE 用
 オプション部品

*ABOUT THE DESTINATION, THE SPREAD "HOW TO MAKE USE OF THIS PARTS LIST"
 PLEASE SEE.
 仕向地については、見開きの (パーツリストご利用に際して) を参照して下さい。

17. TABLE & STAND COMPONENTS

脚卓關係

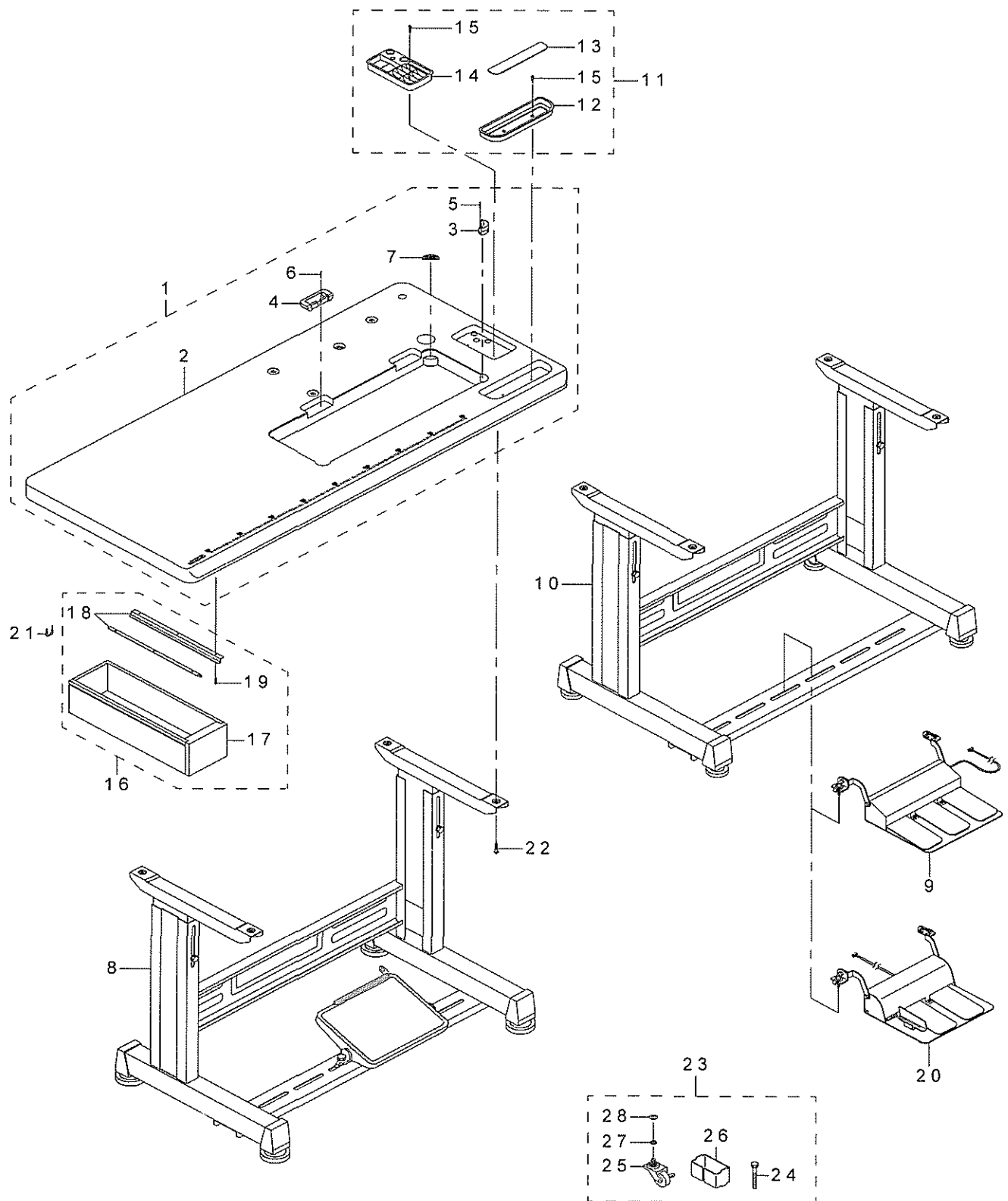

REF.NO	NOTE	PART NO	DESCRIPTION	品名	Qty
1		236-42259	TABLE ASM.	テーブル(組)	1
2		236-42200	TABLE	テーブル	(1)
3		110-75900	RUBBER SPACER	頭部支えゴム座	(2)
4		110-75801	RUBBER SPACER	ゴムヒンジ座	(2)
5		B8210-012-000	CUSHION SET NAIL	釘(20ミリ)	(4)
6		B8210-012-000	CUSHION SET NAIL	釘(20ミリ)	(4)
7		D8226-555-E00	FRAME RUBBER CUSHION A	頭部クッション座	(2)
8	#01	111-57567	T LEG JUNCTION	T脚結合	1
9	#02	GPB-700010A0	3-JOINT PEDAL, 70	3連ペダル組70(SC-1シリーズ)	1
10	* #02	111-57559	T-STAND ASM.	T脚(組)	1
11		111-55769	SMALL CASTINGS BOX B ASM.	テーブル小物入れ B組	1
12		111-56007	CASE	小物入れ	(1)
13		111-55801	CASE MAGNET	小物入れマグネット	(1)
14		111-55751	CASE ASM. B	小物入れ B(組)	(1)
15		SK-3382001-SC	WOOD SCREW D=3.8 L=20	丸木ねじ D=3.8 L=20	(4)
16		111-55157	DRAWER ASM.	引き出し組	1
17		111-55108	DRAWER	引き出し	(1)
18		111-55207	DRAWER SUPPORT	引き出し支え	(2)
19		SK-3311600-SE	WOOD SCREW D=3.1 L=16	木ねじ D=3.1 L=16	(6)
20	#02	GPB-710010A0	2-PEDAL ASM., 71	2連ペダル組71(SC-1シリーズ)	1
21		D8204-555-D00	DRAWER STOPPER	引き出しストッパー	1
22		SK-3513200-SC	WOOD SCREW D=5.1 L=32	丸木ねじ D=5.1 L=32	4
23	* #03	111-59456	CASTER ASM.	キャスター組	1
24		SM-9086523-SE	HEXAGONAL BOLT	六角ボルト	(2)
25		111-59407	CASTER	キャスター	(4)
26		111-59506	STRUT AUXILIARY PLATE	下支柱補助板	(2)
27		WS-0861410-KR	SPRING WASHER 8.6X15X1.4	ばね座金 8.6 X 15 X 1.4	(2)
28		WP-0871602-SE	WASHER 8.7X18X1.6	平座金 8.7 X 18 X 1.6	(2)
		NOTE(注記)	#01....FOR JT-D950 #02....FOR JT-D95A,-D95B #03....OPTIONAL PARTS	JT-D950用 JT-D95A,-D95B用 オプション部品	

18. SPECIAL ORDER PART

特別注文部品

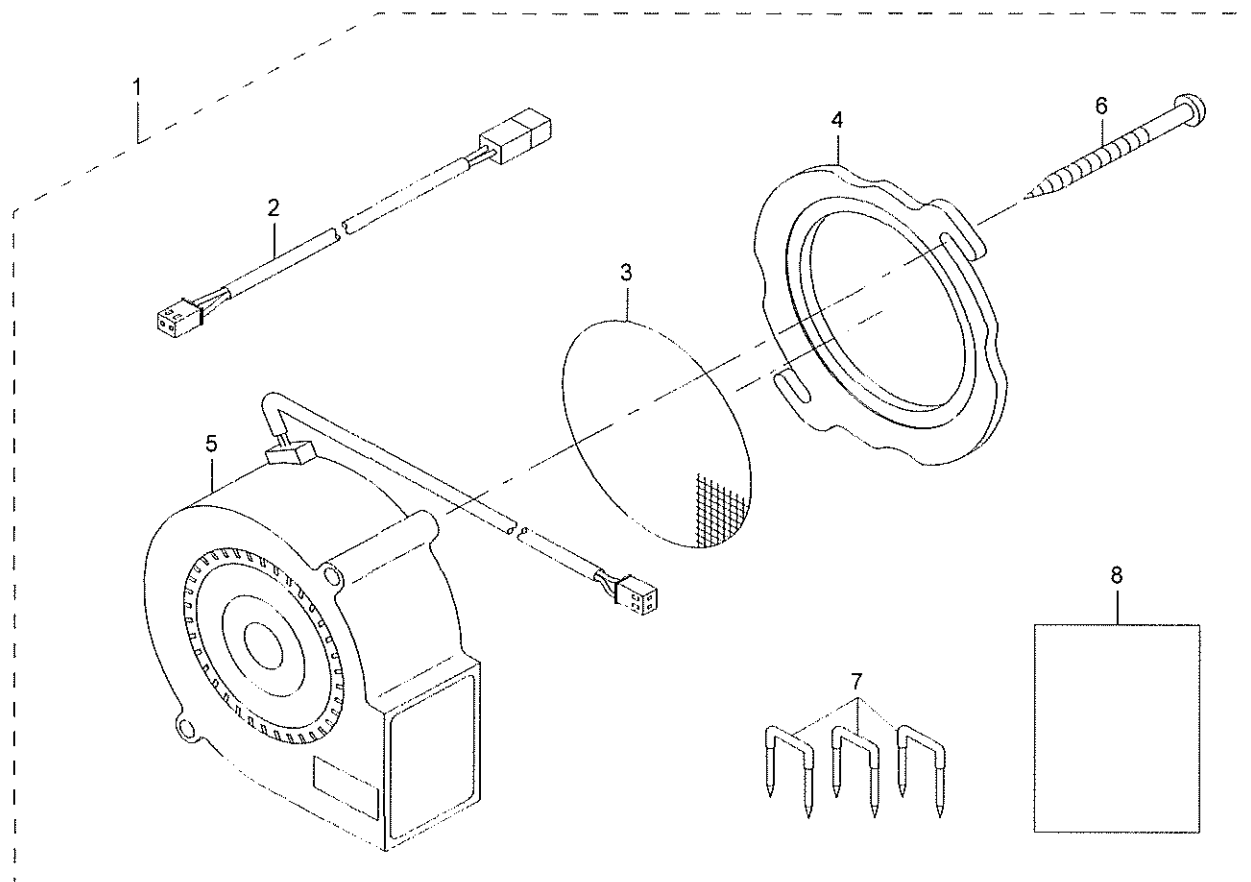

REF.NO	NOTE	PART NO	DESCRIPTION	品名	Qty
1		400-65571	ELECTRIC FAN HOOK COOLING DEVICE	電動ファン釜冷却装置	1
2		400-44065	FAN_RELAY_CABLE	ファンチェウケイコード	(1)
3		400-64805	FAN FILTER	ファンフィルター	(1)
4		400-64806	FAN COOLING COVER	冷却ファンカバーファン	(1)
5		400-65564	FAN MOTOR ASSY	ファンモータクミ	(1)
6		SK-3415001-SE	SCREW D=4.1 L=50	マルモクネジ D=4.1 L=50	(2)
7		MAO-11532000	CORD STAPLE	コード ステツプル	(3)
8		400-65572	HOOK COOLING DEVICE INSTRUCTION	電動ファン釜冷却装置取扱説明書	(1)

19. LIST FOR INFORMATION OF CHANGE

変更情報リスト

As to the place changed, refer to the corresponding Rev. No.
 When previous parts (Obsoleted part) and new parts (Added parts) are not interchangeable with each other:
 In this case, even obsoleted parts (D.) can be ordered with the obsoleted part number, so select the parts with changed dates and place your orders.

変更箇所は、該当Rev. No. 版をご参照ください。
 部品の互換性がない変更の場合は、削除された品番でも、ご注文できます。

40089326

No. 1532-01 Rev. No.

*A: Added parts 追加部品 / D: Obsoleted parts 削除部品 / E: Erratum 訂正

* Rev. No.	Page 頁	Ref. No.	Parts No. 品番	* Rev. No.	Page 頁	Ref. No.	Parts No. 品番
D 00	2	7	SL-6061292-TN	A 01	2	7	SM-6061002-TP
D 00	2	26	SL-6052592-TN	A 01	2	26	SM-6052502-TP
D 00	2	35	SL-6061492-TN	A 01	2	35	SM-6061202-TP
				A 01	2	93	WP-0621016-SD
				A 01	2	94	WP-0621016-SD
				A 01	2	95	WP-0501016-SD
				A 01	2	96	EA-9500B01-00
				A 01	2	97	400-94561
D 00	6	27	400-86602	A 01	6	27	228-86907
D 00	6	28	400-86604	A 01	6	28	228-87004
				A 01	6	46	400-32269
D 00	8	37	SL-6051492-TN	A 01	8	37	SM-6051402-TP
				A 01	8	55	WP-0501016-SD
D 00	10	19	SM-6051600-SP	A 01	10	19	SM-6051602-TP
D 00	10	29	235-33904	A 01	10	29	229-11804
D 00	10	32	400-86611	A 01	10	32	235-34506
				A 01	10	40	400-95847
				A 01	10	51	400-93035
D 00	12	72	B9117-552-A00	A 01	12	72	400-91141
D 00	14	28	SL-6061292-TN	A 01	14	28	SM-6061002-TP
				A 01	14	41	400-95843
D 00	14	49	SM-6061002-TP	A 01	14	49	SM-6061010-TP
D 00	14	50	400-86707	A 01	14	50	400-95870
				A 01	14	81	WP-0621016-SD
				A 01	14	82	400-95218
				A 01	14	83	400-95873
				A 01	18	12	400-95844
				A 01	19	5	400-95175
D 00	21	6	110-47107	A 01	21	6	229-32008
D 00	22	32	B9117-552-A00	A 01	22	32	400-91141
D 00	24	24	110-38759	A 01	24	24	400-00264
				A 01	24	28	D1837-555-BAA-A
D 00	28	9	111-59365				
D 00	28	10	111-59357	A 01	28	10	111-57559
				A 01	28	23	111-59456

NUMERICAL INDEX OF PARTS

索引

PART NO 品番	PAGE 頁	REF NO	PART NO 品番	PAGE 頁	REF NO	PART NO 品番	PAGE 頁	REF NO	PART NO 品番	PAGE 頁	REF NO
B1109-012-10B	2	85	HW-5000700-00	19	8	SB-3070002-0B	6	43	SM-6061010-TP	14	49
B1109-552-000	2	92	HX-0004300-00	22	9	SB-3070002-0C	6	44	SM-6061202-TP	2	35
B1116-210-D00	14	51				SB-3070002-0D	6	45	SM-6061610-SC	20	21
B1116-210-D00	21	7	J1063-000-000	26	33	SB-3070002-00	6	41	SM-8040802-TP	4	21
B1116-210-D00	21	8				SB-3200006-0A	12	48	SM-8050412-TP	6	48
B1116-804-000	14	40	MAO-11532000	29	7	SB-3200006-0B	12	49	SM-8050502-TP	4	22
B1223-771-000	14	80	MC-2005006-50	22	26	SB-3200006-0C	12	50	SM-80506A2-TP	10	4
B1414-555-000	6	32	MC-2005006-50	24	7	SD-0460703-TP	14	8	SM-8051610-SP	6	20
B1505-552-000-A	26	6	MC-2005007-50	6	35	SD-0460703-TP	23	22	SM-80606A2-TP	6	6
B1521-555-000	8	23	MC-2005007-50	22	27	SD-0460703-TP	26	18	SM-80606A2-TP	10	6
B1524-012-0BA	8	26	MC-2005013-00	22	25	SD-0500131-TP	26	19	SM-80606A2-TP	10	38
B1613-012-100	12	25	MDB-100B0900	22	22	SD-0500701-TP	14	77	SM-80606A2-TP	10	41
B3114-232-000	26	31	MDB-100B0900	24	6	SD-0630275-SP	14	73	SM-80606A2-TP	10	50
B3115-552-000	2	51	MDB-100B1100	6	34	SD-0640321-SP	14	69	SM-80606A2-TP	14	43
B3115-552-000	24	15	MDB-100B1100	22	21	SD-0640631-TP	14	71	SM-80606A2-TP	26	42
B3115-552-000	26	25	MDB-100B1100	24	3	SD-0641456-TP	14	17	SM-80608A2-TP	2	46
B3118-552-F00	8	54	MDB-100B1400	6	36	SD-0650321-TP	19	25	SM-80608A2-TP	2	67
B3120-125-000	2	52	MDB-100B1400	22	24	SD-0720331-SP	21	25	SM-80608A2-TP	2	70
B3120-125-000	24	16	MDB-100B2100	22	23	SK-3311600-SE	28	19	SM-80608A2-TP	6	11
B3120-125-000	26	26	MDB-100B2100	26	4	SK-3382001-SC	28	15	SM-80608A2-TP	6	14
B3126-012-000	2	53	MDF-RX1600C0	22	19	SK-3415001-SE	29	6	SM-80608A2-TP	6	17
B3126-012-000	24	13	MML-007600CA	22	20	SK-3513200-SC	28	22	SM-80608A2-TP	6	23
B3126-012-000	26	27				SL-4030631-SC	19	26	SM-80608A2-TP	6	39
B3128-012-000	2	54	NM-6040000-SN	14	24	SL-4030641-SE	19	27	SM-80608A2-TP	10	26
B3128-012-000	26	28	NM-6040001-SP	2	42	SL-6040892-TN	16	42	SM-80608A2-TP	12	82
B3129-012-A00	2	55	NM-6040001-SP	14	46	SL-6051492-TN	16	28	SM-80608A2-TP	14	54
B3132-552-000	2	56	NM-6050001-SC	14	57	SL-6051492-TN	16	43	SM-8060812-TP	14	35
B3132-552-000	24	12	NM-6050001-SE	20	6	SL-6052592-TN	6	49	SM-8061010-TP	14	68
B3132-552-000	26	29	NM-6050001-SE	20	13	SL-6053592-TN	8	52	SM-8061050-TP	14	67
B3214-047-000	2	66	NM-6050001-SP	18	10	SL-6061292-TN	16	27	SM-8063012-TR	21	12
B4123-522-00A	12	28	NM-6060001-SE	21	11	SM-0051001-SC	4	31	SM-8081652-TP	6	5
B4123-522-00B	12	29	NM-6060003-SE	8	31	SM-0051001-SC	4	32	SM-8081652-TP	26	41
B4123-522-00C	12	30	NM-6160511-SE	20	18	SM-2040750-TP	2	28	SM-8480652-TP	18	36
B8210-012-000	28	5	NS-6090310-SP	19	21	SM-2040955-TP	2	27	SM-9061203-SE	21	34
B8210-012-000	28	6	NS-6110310-SP	14	78	SM-4021201-SC	2	79	SM-9061853-SR	21	26
B8228-125-000	16	47	NS-6110310-SP	19	22	SM-4040601-SC	16	45	SM-9061853-SR	21	27
B9117-012-000	22	31	NS-6150310-SP	14	75	SM-4040655-SP	2	22	SM-9062053-SR	21	21
B9117-012-000	26	5	NS-6150310-SP	21	22	SM-4040655-SP	2	36	SM-9086523-SE	28	24
B9121-012-0A0	22	18	NS-6620310-SP	8	44	SM-4040655-SP	8	36	SQ-2050453-MZ	16	14
			NS-6660410-SH	14	21	SM-4040655-SP	12	42	SS-2060210-SP	14	9
			NS-6660430-SP	14	22	SM-4041055-SP	14	11	SS-2060210-SP	23	15
CM-3002000-01	2	23				SM-4050501-SC	23	2	SS-2060210-SP	26	20
CM-3002000-03	2	25				SM-4050501-SC	24	21	SS-4080620-TP	12	27
CM-3013000-01	2	29	RC-0370411-KP	19	23	SM-4050555-SP	2	10	SS-4080620-TP	14	10
CM-6001001-01	2	87	RC-0560711-KP	4	18	SM-4050555-SP	2	80	SS-4080620-TP	23	16
CM-6001002-01	22	30	RC-1200001-KP	12	83	SM-4050555-SP	8	35	SS-4080620-TP	26	21
CM-6006001-01	2	88	RE-0400000-K0	4	19	SM-4050555-SP	14	61	SS-4110615-SP	19	30
CQ-2000000-01	16	20	RE-0500000-K0	8	10	SM-4050855-SP	2	9	SS-6060210-SP	2	18
CQ-2500000-01	16	9	RE-0500000-K0	8	11	SM-4050855-SP	2	19	SS-6090510-TP	14	15
CS-1000881-TP	6	47	RE-0500000-K0	8	28	SM-4050855-SP	12	19	SS-6090540-SP	19	28
			RE-0500000-K0	8	45	SM-4051055-SP	2	5	SS-6090620-TP	12	7
D1524-555-DBB	24	5	RE-0500000-K0	10	24	SM-4051055-SP	2	31	SS-6090670-TP	6	31
D1524-555-EBL	26	7	RE-0500000-K0	14	31	SM-4051055-SP	2	89	SS-6090670-TP	12	21
D1613-155-W00	24	4	RE-0500000-K0	19	24	SM-4051055-SP	4	33	SS-6090670-TP	12	53
D1837-555-BAA-A	12	67	RE-0600000-K0	6	55	SM-4051055-SP	18	8	SS-6110420-TP	23	7
D1837-555-BAA-A	24	28	RE-0700000-K0	14	39	SM-4051055-SP	18	24	SS-6110650-TP	12	35
D2406-555-D0H	14	7	RE-1000000-K0	21	23	SM-4051055-SP	19	37	SS-6110710-TP	14	30
D2468-555-B00	18	5	RE-1000000-K0	21	24	SM-4051055-SP	2	32	SS-6121610-SP	12	11
D3128-555-D00	24	18	RE-1200000-K0	18	4	SM-4051255-SP	20	12	SS-6121860-SP	10	35
D3129-555-D00	24	17	RO-0360802-00	12	85	SM-4051405-SE	4	20	SS-7080510-TP	6	57
D5119-206-K0K	8	50	RO-0371801-00	8	25	SM-5040655-SN	16	29	SS-7091110-TP	8	27
D8204-555-D00	28	21	RO-0371801-00	16	39	SM-6040602-TP	8	9	SS-7110740-TP	14	65
D8226-555-E00	28	7	RO-0442401-00	8	53	SM-6040800-SP	14	52	SS-7110740-TP	18	19
			RO-0481901-00	16	44	SM-6051400-SP	8	4	SS-7110740-TP	18	29
EA-9500B01-00	2	78	RO-0681901-00	16	16	SM-6051400-SP	12	17	SS-8090670-SP	2	58
EA-9500B01-00	2	96	RO-0801502-00	2	83	SM-6051402-TP	8	37	SS-8090670-SP	24	19
EA-9500B01-00	6	50	RO-0922702-00	10	43	SM-6051602-TP	10	10	SS-8090670-SP	26	32
EA-9500B01-00	18	18	RO-0982401-00	16	25	SM-6051602-TP	10	19	SS-8150822-TP	12	3
EA-9500B01-00	18	28	RO-1721801-00	16	26	SM-6051602-TP	18	14	SS-8151150-TP	12	39
			RO-1952401-00	16	4	SM-6051850-TP	10	28	SS-8151150-TP	26	37
GPK-700010A0	28	9				SM-6052502-TP	2	26	SS-8660610-TP	12	24
GPK-710010A0	28	20	SB-1170012-00	12	51	SM-6061002-TP	2	7	SS-8661012-TP	12	46
			SB-1200026-00	12	80						
HK-0346400-0B	14	23	SB-1200027-00	6	8						
HK-0346400-0B	18	2	SB-1200027-00	6	21						
HK-0346400-0B	19	7	SB-3070002-0A	6	42						

NUMERICAL INDEX OF PARTS

索引

PART NO 品番	PAGE 頁	REF NO	PART NO 品番	PAGE 頁	REF NO	PART NO 品番	PAGE 頁	REF NO	PART NO 品番	PAGE 頁	REF NO
SS-8661012-TP	12	55	114-09257	26	15	229-34400	21	31	236-29306	16	10
SS-8661012-TP	12	66	131-70105	16	6	229-34509	21	32	236-29306	24	26
			131-71004	16	5	229-34608	21	33	236-29405	16	11
TA-0850604-R0	6	40				229-44508	2	21	236-29900	2	82
TA-0850604-R0	6	54	225-02504	22	7	229-44508	8	34	236-30007	10	23
TA-1250406-R0	2	39	228-86907	6	27	229-47907	14	4	236-30007	16	17
TA-1250406-R0	2	40	228-87004	6	28	229-47907	23	19	236-30007	16	18
TA-1250406-R0	2	43	228-90206	23	9	229-48202	14	6	236-30007	16	19
TA-1470704-R0	2	41	228-90305	23	10	229-50000	14	74	236-30106	16	21
			228-90404	23	8	229-51552	2	8	236-30106	16	22
WP-0430800-SC	14	25	228-91204	6	53	229-52501	10	27	236-30403	16	34
WP-0450801-SP	14	66	228-95908	23	14	229-55504	19	36	236-30502	16	35
WP-0450826-SC	4	23	228-96005	23	21	229-55900	19	18	236-31708	18	20
WP-0480856-SP	12	18	228-96252	23	12	229-56007	19	20	236-31708	18	30
WP-0501016-SD	2	95	229-01201	2	14	229-56106	19	9	236-31757	18	15
WP-0501016-SD	8	55	229-01250	2	12	229-56205	19	10	236-31807	18	21
WP-0550800-SP	2	90	229-01300	2	16	229-56304	19	11	236-31807	18	31
WP-0550800-SP	18	7	229-01300	2	17	229-56809	19	12	236-31906	18	22
WP-0551016-SH	18	9	229-01805	2	81	229-56908	19	13	236-31906	18	32
WP-0621016-SD	2	93	229-02506	2	30	229-57005	19	14	236-32003	18	23
WP-0621016-SD	2	94	229-02704	2	15	229-57203	19	15	236-32102	18	16
WP-0621016-SD	8	33	229-02753	2	13	229-58003	22	17	236-32102	18	26
WP-0621016-SD	14	81	229-04106	12	23	229-58052	22	12	236-32250	18	27
WP-0621016-SH	14	76	229-04155	12	22	235-34506	10	32	236-32359	18	17
WP-0650876-SD	21	18	229-06309	6	56	235-40305	24	27	236-32607	18	33
WP-0651001-SC	19	34	229-06408	6	30	236-00505	2	4	236-32656	18	25
WP-0661016-SP	19	33	229-06457	6	29	236-01305	2	84	236-38109	2	73
WP-0841600-SD	14	38	229-07406	8	15	236-05207	6	10	236-38208	2	74
WP-0871602-SE	28	28	229-07802	8	22	236-08003	6	25	236-38307	2	75
WP-1602616-SZ	18	6	229-08008	8	8	236-08102	6	26	236-38406	2	76
WP-1612616-SE	20	19	229-08552	8	24	236-09001	8	1	236-38554	2	77
WP-1751616-SD	10	33	229-08909	8	29	236-09308	8	12	236-39008	21	5
WS-0510002-KN	20	5	229-10509	10	11	236-09357	8	5	236-39107	21	10
WS-0610002-KN	18	11	229-11002	12	13	236-09456	8	6	236-39156	21	9
WS-0861410-KR	28	27	229-11101	12	6	236-09605	8	7	236-39206	21	13
WS-1643202-KR	20	20	229-11804	10	29	236-09704	8	14	236-39305	21	14
			229-12000	10	31	236-10207	8	16	236-39404	21	15
106-18304	14	32	229-12109	10	30	236-10306	8	17	236-39503	21	16
110-01005	10	48	229-16506	12	60	236-10504	8	48	236-39602	21	17
110-01906	24	1	229-16555	12	59	236-10652	8	49	236-39701	22	8
110-15906	12	61	229-20300	8	40	236-10702	8	51	236-40006	2	47
110-28008	2	86	229-20409	8	41	236-11106	8	47	236-42200	28	2
110-38650	12	69	229-20607	2	60	236-12609	10	25	236-42259	28	1
110-40052	14	2	229-21308	4	25	236-13409	10	39	236-45609	26	2
110-40052	23	17	229-21407	4	27	236-13706	10	16	262-26209	14	59
110-40409	14	5	229-21506	4	28	236-14506	12	26	262-60109	4	2
110-40409	23	20	229-21704	4	29	236-16006	12	2	262-60208	4	3
110-43304	14	20	229-25101	16	24	236-16204	12	20	262-60307	4	4
110-45002	2	62	229-26000	22	16	236-16402	12	32	262-60406	4	5
110-45200	2	63	229-26208	22	13	236-16600	12	33	262-60505	4	6
110-62007	26	48	229-26356	22	14	236-16709	12	14	262-60604	4	7
110-62601	26	47	229-26505	22	15	236-18101	12	47	262-60802	4	8
110-72402	2	65	229-30309	20	14	236-18309	12	52	262-61008	4	9
110-73954	2	61	229-30358	20	1	236-19000	26	36	262-61206	4	10
110-75801	28	4	229-30408	20	10	236-19059	26	35	262-61305	4	11
110-75900	28	3	229-30507	20	9	236-20008	12	56	262-61503	4	12
110-79506	12	84	229-30556	20	15	236-20156	12	57	262-61602	4	13
110-92251	26	10	229-30705	20	7	236-20206	12	58	262-61701	4	14
110-93606	2	64	229-30804	20	17	236-20404	12	74			
110-95502	26	13	229-30903	20	16	236-20503	12	54	312-56803	14	37
111-41355	12	68	229-31000	20	3	236-20701	12	62			
111-55108	28	17	229-31109	20	4	236-20800	12	63	400-00264	24	24
111-55157	28	16	229-31307	20	11	236-20909	12	64	400-00264	26	22
111-55207	28	18	229-31406	20	8	236-21006	12	65	400-00344	16	13
111-55751	28	14	229-31604	22	4	236-26005	2	50	400-00391	12	37
111-55769	28	11	229-32008	21	6	236-26005	24	11	400-00392	12	38
111-55801	28	13	229-32404	21	20	236-26005	26	24	400-04171	6	4
111-56007	28	12	229-32453	21	19	236-26104	2	69	400-04171	26	40
111-57559	28	10	229-32800	22	3	236-26203	6	33	400-06323	23	23
111-57567	28	8	229-33006	22	33	236-26351	8	42	400-06323	24	25
111-59407	28	25	229-33105	22	11	236-26807	8	43	400-06716	10	49
111-59456	28	23	229-33204	22	6	236-28803	16	40	400-09894	26	16
111-59506	28	26	229-34202	21	29	236-28902	16	36	400-11144	4	15
111-62104	24	2	229-34251	21	28	236-29207	16	8	400-13595	16	30
114-03003	26	49	229-34301	21	30	236-29256	16	7	400-14837	4	16

NUMERICAL INDEX OF PARTS

索引

PART NO 品番	PAGE 頁	REF NO	PART NO 品番	PAGE 頁	REF NO	PART NO 品番	PAGE 頁	REF NO	PART NO 品番	PAGE 頁	REF NO
400-15671	14	45	400-61246	12	8	400-86699	18	35			
400-20454	6	18	400-61767	26	3	400-86704	10	8			
400-20455	6	19	400-62321	21	2	400-86705	10	9			
400-22407	2	11	400-62323	21	4	400-86706	10	12			
400-23021	4	1	400-62684	20	2	400-86708	14	55			
400-23022	4	17	400-63697	26	46	400-86709	14	58			
400-24081	22	5	400-64805	29	3	400-86710	14	56			
400-24124	26	34	400-64806	29	4	400-86711	14	29			
400-24843	2	49	400-64839	26	8	400-86712	14	79			
400-24845	2	57	400-65564	29	5	400-86713	2	6			
400-24845	24	14	400-65571	29	1	400-86714	2	34			
400-24845	26	30	400-65572	29	8	400-86716	19	35			
400-25729	6	3	400-69097	2	24	400-86717	19	19			
400-26277	12	5	400-69110	2	20	400-86723	19	3			
400-26278	12	31	400-69369	26	43	400-86724	19	4			
400-26281	12	16	400-69370	26	44	400-86727	14	27			
400-26282	12	36	400-70090	22	28	400-86728	2	44			
400-26287	12	41	400-75404	16	23	400-86729	6	22			
400-26288	12	43	400-77851	19	29	400-86730	12	81			
400-29398	14	16	400-77852	19	16	400-86731	6	24			
400-30786	12	71	400-77853	19	2	400-86732	2	33			
400-32269	6	46	400-82059	16	1	400-86733	6	7			
400-34246	16	3	400-82060	16	2	400-86735	10	1			
400-35589	2	37	400-82061	16	46	400-86736	10	37			
400-36433	10	34	400-82078	8	30	400-86737	10	20			
400-36706	8	32	400-86597	6	1	400-86738	10	15			
400-36997	14	14	400-86602	23	5	400-86739	10	21			
400-36998	14	12	400-86602	24	23	400-86740	12	70			
400-37003	6	2	400-86604	23	4	400-86741	12	78			
400-37005	12	15	400-86604	24	22	400-86742	12	79			
400-37006	6	16	400-86605	23	1	400-86743	12	34			
400-37007	6	15	400-86605	24	20	400-86744	12	73			
400-37008	4	30	400-86606	8	2	400-86746	14	18			
400-37141	8	19	400-86607	8	3	400-86747	14	53			
400-37144	8	20	400-86608	10	5	400-86748	14	44			
400-37146	23	3	400-86609	10	22	400-86749	16	31			
400-37158	2	1	400-86610	10	42	400-86750	18	1			
400-37166	16	12	400-86612	10	44	400-86753	18	3			
400-37192	12	1	400-86613	10	45	400-86757	12	44			
400-37313	26	23	400-86614	10	14	400-86759	18	37			
400-37359	8	18	400-86615	10	7	400-86760	8	13			
400-37365	12	4	400-86616	10	13	400-88958	4	24			
400-37370	6	37	400-86617	10	36	400-88959	4	26			
400-37439	24	9	400-86618	12	77	400-89196	6	58			
400-37479	24	10	400-86621	14	60	400-89263	14	19			
400-37488	2	48	400-86622	14	36	400-89264	19	6			
400-37502	16	38	400-86623	14	47	400-89274	23	6			
400-38328	16	37	400-86624	14	42	400-89323	22	29			
400-41161	2	2	400-86628	14	70	400-89605	26	1			
400-42079	12	10	400-86631	14	62	400-89607	12	75			
400-44065	29	2	400-86632	14	63	400-89610	26	9			
400-44189	14	3	400-86633	14	64	400-89663	22	1			
400-44190	26	14	400-86634	14	33	400-89665	21	1			
400-44857	6	9	400-86635	14	34	400-89671	21	3			
400-50581	23	24	400-86636	14	48	400-89672	14	26			
400-50582	8	39	400-86637	14	72	400-90100	10	46			
400-50583	8	21	400-86643	8	38	400-90101	10	47			
400-50584	24	8	400-86646	16	32	400-90527	6	38			
400-50585	14	1	400-86647	16	33	400-90528	6	52			
400-50586	23	13	400-86648	16	15	400-90529	6	51			
400-50587	26	12	400-86655	18	34	400-91140	22	2			
400-50588	23	18	400-86659	2	71	400-91141	12	72			
400-50589	26	17	400-86660	2	72	400-91141	22	32			
400-51473	6	12	400-86674	10	17	400-91141	23	11			
400-51474	6	13	400-86675	10	18	400-91397	2	91			
400-52819	2	3	400-86676	19	1	400-91461	2	38			
400-52933	2	45	400-86678	19	17	400-93035	10	51			
400-53411	26	39	400-86679	19	32	400-94561	2	97			
400-53720	12	40	400-86680	19	31	400-95175	19	5			
400-55058	26	38	400-86690	12	45	400-95218	14	82			
400-55591	22	10	400-86693	16	41	400-95843	14	41			
400-55604	26	11	400-86695	10	2	400-95844	18	12			
400-56622	8	46	400-86696	10	3	400-95847	10	40			
400-58504	12	9	400-86697	16	48	400-95870	14	50			
400-61215	14	13	400-86698	18	13	400-95873	14	83			

JUKI®

JUKI 株式会社

〒 206-8551 東京都多摩市鶴牧 2-11-1

工業用ミシン事業部

TEL.042-357-2371(ダイヤルイン) FAX.042-357-2274

JUKI CORPORATION

INDUSTRIAL SEWING MACHINE DIVISION
2-11-1, TSURUMAKI, TAMA-SHI,
TOKYO, 206-8551, JAPAN
PHONE:(81)42-357-2371
FAX:(81)42-357-2274

Copyright© 2009-2010 JUKI CORPORATION
本書の内容を無断で転載、複写することを
禁止します。
All rights reserved throughout the world.

お買い求め、ご相談は

To order or for further
information,
please contact:

※このパーツリストは商品改良のため予告なく変更する事があります。

*The description covered in this parts list is subject to change for improvement of the commodity without notice.

※このパーツリストは2010年2月現在の商品仕様で編集したものです。

*This parts list is edited in accordance with the product specifications as of February 2010.

Printed in Japan