

**961-16-2/0**

**961-16-1/0**

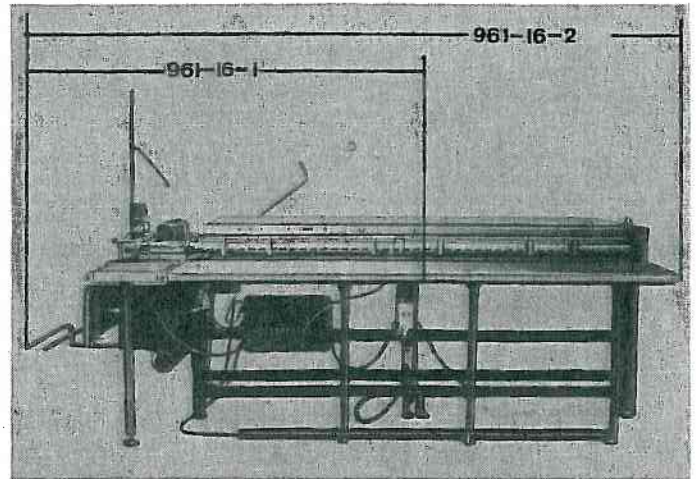
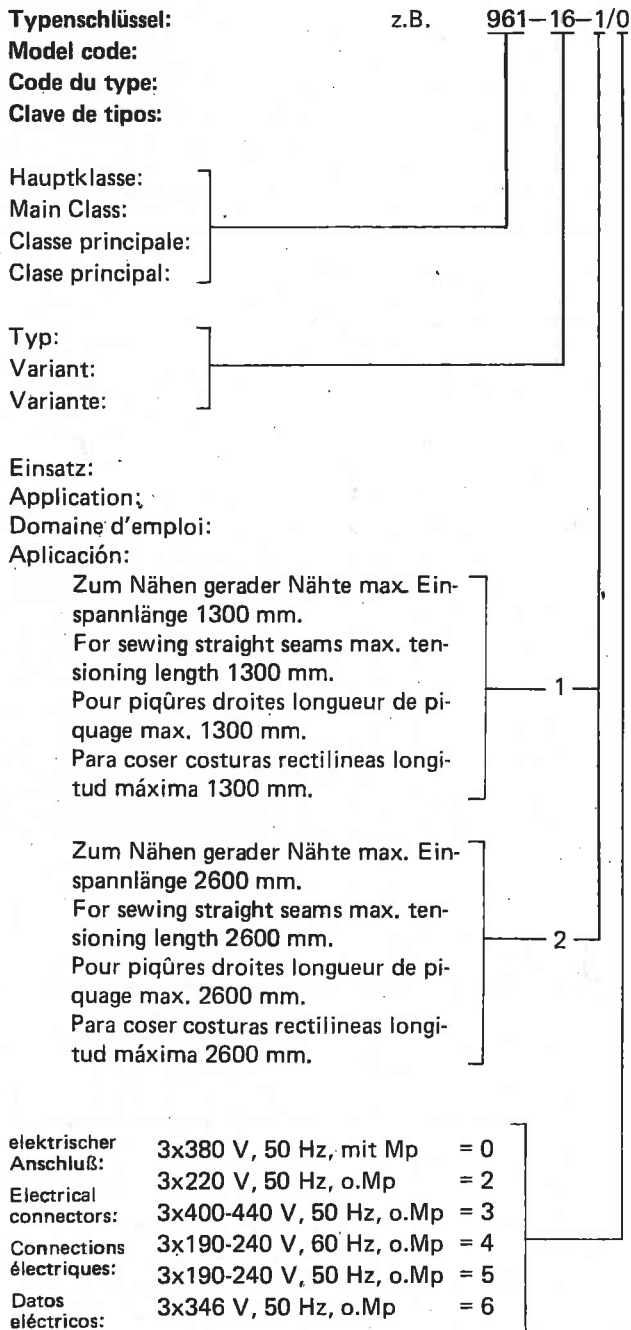

**Ersatzteilleiste**

**Spare Parts**

**Pièces de rechange**

**Piezas de repuesto**

**Archiv-Expl.**

Kochs Adler Aktiengesellschaft  
Postfach 103 + 105, D-4800 Bielefeld 1  
Telefon: (0521) 2097-1  
Telex: 932759 adlr d  
Telegramme: Adler Bielefeld

Printed in West Germany  
Änderungen vorbehalten

TL 961-16- /4-Okt. 1982

Reihenfolge und Aufteilung der Bildtafeln  
 Sequence and breakdown of the illustrations  
 Suite et division des illustrations

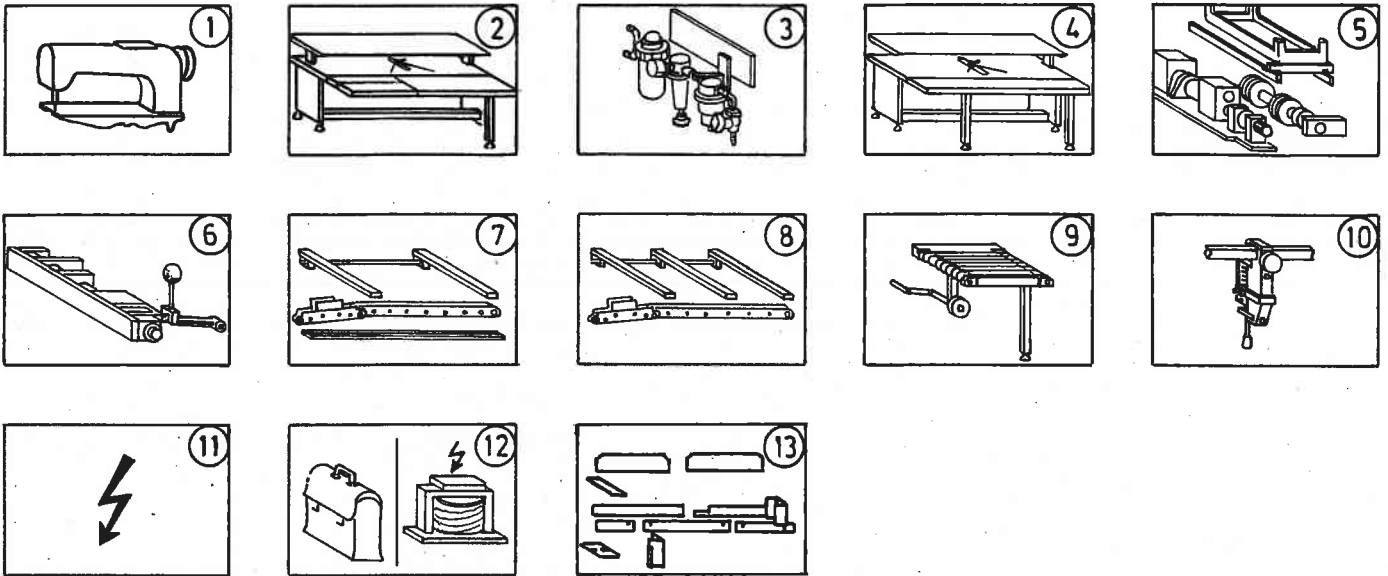

KL:	1	2	3	4	5	6	7	8	9	10	11	12	13
<del>961-16-1</del>	✗	✗	✗	—	✗	✗	✗	—	✗	✗	✗	✗	✗
961-16-2	✗	✗	✗	✗	✗	✗	—	✗	✗	✗	✗	✗	✗