

**2-Needle, Needle-feed, Lockstitch Machine
with an Automatic Thread Trimmer
(without Thread Trimmer)**

二本針本縫針送り自動糸切りミシン

LH-3528-7

LH-3528 (糸切り無)

PARTS LIST

HOW TO MAKE USE OF THIS PARTS LIST

1. Explanation of codes

1) "*" mark.....means this part is changed from the previous parts book.

As to the details of the change, refer to "List for information of change".

2) "01"refer to "Note" explanation at bottom of page.

2. Codes on the "Qty" column

· Each numeral indicates the number of parts required.

· "0.1" and "2.5" indicate the length (in meters) of the respective parts.

3. Parentheses mean that the corresponding part is a subpart that constructs an assembly part.

4. Dotted lines on the Figures indicate assembly parts.

5. As to the parts with marks of "☆"(consumable parts) and "◎" (optional parts) on the respective parts, it is recommended to prepare spares.

パーツリストご利用に際して

1. "注記" 欄の記号説明

1) "*" 印前回のパーツブックに比較して今回変更された部品を意味します。

変更内容は" 変更情報リスト" を参照してください。

2) "01"ページ下の" 注記" の説明を参照してください。

2. 数量欄の数字は、個数を表し、0.1、2.5等の数値は、長さ（単位メートル）を表します。

3. 数量欄の（ ）は、組部品を構成している子部品であることを意味します。

4. イラストページの — — — — 枠は、組構成であることを意味します。

5. リストページの"☆"（消耗部品）、"◎"（オプション部品）の印が付いた部品は、予備を準備しておくことをお奨めします。

CONTENTS

目 次

1. FRAME & MISCELLANEOUS COVER COMPONENTS	1
頭部・外装関係	
2. MAIN SHAFT, THREAD TAKE-UP & NEEDLE BAR COMPONENTS	3
上軸・天秤・針棒関係	
3. TENSION POST COMPONENTS	5
糸調子関係	
4. HOOK & HOOK DRIVING SHAFT COMPONENTS	7
釜・下軸関係	
5. FEED MECHANISM COMPONENTS	9
送り関係	
6. PRESSER BAR & TENSION RELEASE COMPONENTS	11
押さえ棒・糸ゆるめ関係	
7. THREAD TRIMMER MECHANISM COMPONENTS (FOR LH-3528-7)	13
糸切り装置関係 (LH-3528-7用)	
8. AUTOMATIC REVERSE FEED MECHANISM COMPONENTS	15
自動逆送り関係	
9. WIPER MECHANISM COMPONENTS (FOR LH-3528-7)	17
ワイパー装置関係 (LH-3528-7用)	
10. LUBRICATION COMPONENTS	19
給油関係	
11. BELT COVER & BOBBIN WINDER COMPONENTS	21
ベルトカバー・糸巻き装置関係	
12. BOTTOM COVER COMPONENTS	22
ボトムカバー関係	
13. AK DEVICE COMPONENTS	23
AK装置関係	
14. THREAD STAND COMPONENTS	25
糸立装置関係	
15. ACCESSORIE PARTS COMPONENTS	27
付属品関係	
16. TABLE OF EXCHANGING GAUGE PARTS (1)(FOR LH-3528)	29
交換ゲージ部品一覧表 (1) (LH-3528用)	
17. TABLE OF EXCHANGING GAUGE PARTS (2)(FOR LH-3528)	30
交換ゲージ部品一覧表 (2) (LH-3528用)	
18. TABLE OF EXCHANGING GAUGE PARTS (FOR LH-3528-7)	31
交換ゲージ部品一覧表 (LH-3528-7用)	
19. LIST FOR INFORMATION OF CHANGE	32
変更情報リスト	
NUMERICAL INDEX OF PARTS	34
索引	

1. FRAME & MISCELLANEOUS COVER COMPONENTS

頭部・外装関係

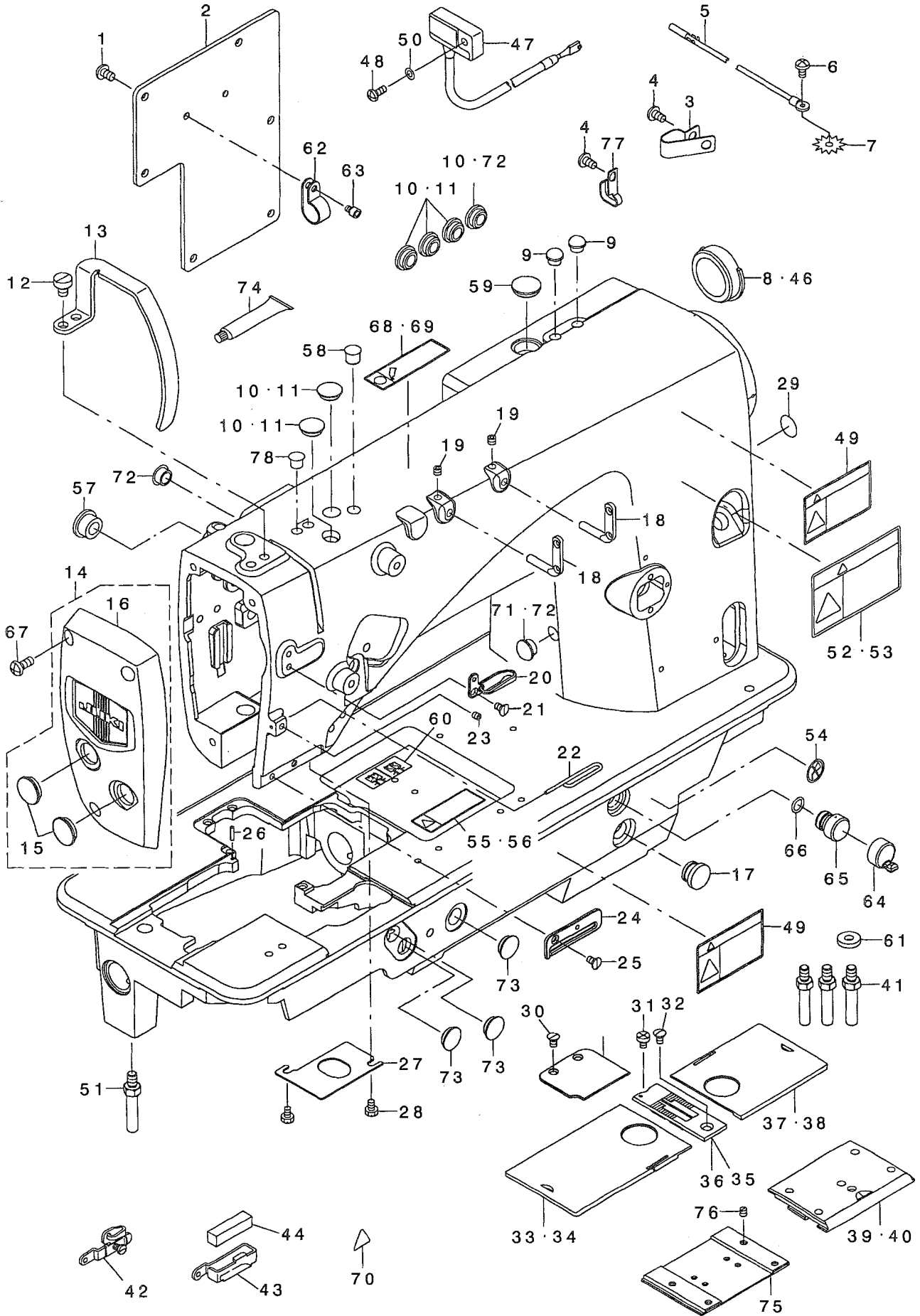

REF. NO	NOTE	PART NO.	DESCRIPTION	品名	Qty
1		SM-4050855-SP	SCREW	ナハネジ M5 L=8	6
2		400-28766	REAR PLATE	リヤ板	1
3	10	D2112-555-B00	CORD HOLDER, LARGE	コードホルダ A	3
4	10	SM-4050855-SP	SCREW	ナハネジ M5 L=8	4
5		236-01057	EARTH CORD ASM.	アースコード(クミ)	1
6		SM-4050855-SP	SCREW	ナハネジ M5 L=8	1
7		WT-0530002-KS	TOOTHED WASHER D=5.3	ハツキサガネ D=5.3	1
8	01	226-19100	CAP	キャップ(イキリナ)	1
9	01	TA-0800504-R0	PLUG D=8 L=4.5	トメシ D=8X4.5	2
10	08	TA-1250406-R0	RUBBER PLUG D=12.5 L=4	トメシ D=12.5 L=4	6
11	07	TA-1250406-R0	RUBBER PLUG D=12.5 L=4	トメシ D=12.5 L=4	5
12		SM-6060800-SP	SCREW M6 L=8	ヒラネジ M6 L=8	2
13		400-28245	THREAD TAKE UP LEVER COVER	スレッドアップカバー	1
14		400-30298	ASSY_FACE_COVER_28	フェイスカバー	1
15		TA-1600406-R0	PLUG	トメシ D=16 L=3.5	(2)
16		400-29641	FACE COVER_28	フェイスカバー	(1)
17		TA-1250705-R0	RUBBER PLUG	トメシ	1
18		229-20706	TWO EYELET	フタツメイカ	2
19		SM-8050412-TP	SCREW M5 L=4	トメネジ M5 L=4	2
20		400-29078	THREAD GUIDE UPPER	イアンナイ	1
21		SM-1040750-TP	SCREW M4 L=7	サコネジ M4 L=7	1
22		400-29347	THREAD GUIDE WIRE	イアンナイ	1
23		SM-8040402-TP	SCREW M4X0.7 L=4	トメネジ M4X0.7 L=4	1
24		400-28707	THREAD GUIDE LOWER	イアンナイ	1
25		SM-1040750-TP	SCREW M4 L=7	サコネジ M4 L=7	1
26		B1104-051-000	THROAT PLATE PIN	ハシタトメピン	1
27		400-28730	PLATE	アゴアテ	1
28		SM-9040603-SC	SCREW M4 L=6	ロツカクネジ M4X0.7 L=6	2
29		229-01805	GROUND MARK	グラウンドマーク	1
30		SM-1040750-TP	SCREW M4 L=7	サコネジ M4 L=7	2
31		SM-6040655-TP	SCREW M4 L=6	ヒラネジ M4 L=6	1
32		SM-2040750-TP	SCREW M4 L=7.4	マササネジ M4 L=7.4	1
33	03	226-01058	BED SLIDE LEFT, ASM., A	スベリ台(ヒタリ) Aクミ	1
34	04	400-25247	ASSY_SLIDE_PLATE-L-A	イキリスベリ台(ヒタリ) L-A-クミ	1
35	03	226-25503	THROAT PLATE 1/4	ハシタ(イキリナ) 1/4" (6.4MM)	1
36	04	400-25492	THROAT PLATE TRIM-1/4	イキリハシタ-1/4	1
37	03	226-00555	BED SLIDE RIGHT, ASM., A	スベリ台(ヒタリ) Aクミ	1
38	04	400-25235	ASSY_SLIDE_PLATE-R-A	イキリスベリ台(ヒタリ) R-A-クミ	1
39	02	400-31358	ASSY_SLIDE_PLATE_F	スベリ台(マエ)イキリナ(クミ)	1
40	01	400-34931	ASSY_SLIDE_PLATE_F	スベリ台(マエ)イキリナ(クミ)	1
41		400-28555	STUD	スタッド	3
42	05	400-34675	THREAD GUIDE ASM_E	ハシタサエ	1
43	06	400-32896	THREAD GUIDE FELT	フェルトイアンナイ	1
44	06	226-03708	FELT	フェルト	1
45		400-28706	AUXILIARY COVER	補助カバー	1
46	02	226-57803	RUBBER PLUG	キャップ(イキリナ)	1
47		400-34053	RESISTANCE PACK AA ASM.	抵抗パック AAクミ	1
48		SM-4041055-SP	SCREW	ナハネジ M4 L=10	1
49		CM-3002001-A1	SAFETY LABEL., 3 (SMALL).	安全ラベル 3(小)	2
50		WP-0430800-SD	WASHER M4	ヒラサガネ M4	1
51		400-35180	BED SCREW STUD_B	キャップ	1
52	07	CM-2002002-01	LABEL 02 C	アラシラベル(エイ)	1
53	08	CM-2002002-02	LABEL 02	アラシラベル(エイ)	1
54		CM-1001000-01	OIL INJECTION PROHIBITION LABE	アラシラベル(エイ)	1
55	08	CM-3011001-02	LABEL 03	アラシラベル(エイ)	1
56	07	CM-3011001-01	LABEL 03 C	アラシラベル(エイ)	1
57		TA-1470704-R0	RUBBER PLUG	トメシ	1
58		TA-0950806-R0	RUBBER PLUG	トメシ	1
59		TA-1650406-R0	PRUG	トメシ D=17 L=3.5	1
60		400-26811	THREADING DIAGRAM	イトオリシ	1
61		400-36690	WASHER	ワッシャー	1
62		EA-9502B02-00	CABLE CLIP C	ケーブルクリップ C	2
63	*	SM-6040552-TP	SCREW M4 L=4.5	ロツカクネジ M4 L=4.5	2
64		236-01305	AIR-DISCHARGING CAP	エア抜き	1
65		236-29900	AIR-DISCHARGING	エア抜き	1
66		RO-0801502-00	RUBBER RING	リング	1
67		SM-4051255-SP	SCREW, M5 L=12.	ナハネジ M5 L=12	3
68	08	CM-2001001-02	LABEL 01	アラシラベル(エイ)	1
69	07	CM-2001001-01	LABEL 01 C	アラシラベル(エイ)	1
70		CM-3002000-01	ATTENTION SEAL	注意シール(16)	1
71	08	TA-1050504-R0	RUBBER PLUG	トメシ	1
72	07	TA-1050504-R0	RUBBER PLUG	トメシ	3
73		TA-1250406-R0	RUBBER PLUG D=12.5 L=4	トメシ D=12.5 L=4	3
74☆		400-06323	JUX1 GREASE A TUBE	グリースチューブ A	1
75	09	232-06709	BED SLIDE (FRONT)A	スベリ台(マエ) A	1
76	09	SS-8110410-TP	SCREW 11/64-40 L=3.5	トメネジ 11/64-40 L=3.5	1
77	*	400-22407	CORD HOLDER	コードホルダ	1
78	*	TA-0750704-R0	RUBBER PLUG	トメシ	2

NOTE (注記)

- 01... FOR LH-3528 LH-3528用
- 02... FOR LH-3528-7 LH-3528-7用
- 03... EXCHANGING GAUGE PARTS
FOR LH-3528(SEE.P.29,30) LH-3528交換ゲージ部品
(29,30ページをご参照下さい。)
- 04... EXCHANGING GAUGE PARTS
FOR LH-3528-7(SEE.P.31) LH-3528-7交換ゲージ部品
(31ページをご参照下さい。)
- 05... OPTIONAL PARTS オプション部品
- 06... TYPE A(Accessorie Parts) A仕様(付属品)
- 07... FOR CHINA 中国用
- 08... EXCEPT CHINA 中国を除く
- 09... SELECTIVE PARTS 選択部品
- 10... FOR LH-3528-0B, LH-3528-7 LH-3528-0B, LH-3528-7用

2. MAIN SHAFT, THREAD TAKE-UP & NEEDLE BAR COMPONENTS

上軸・天秤・針棒関係

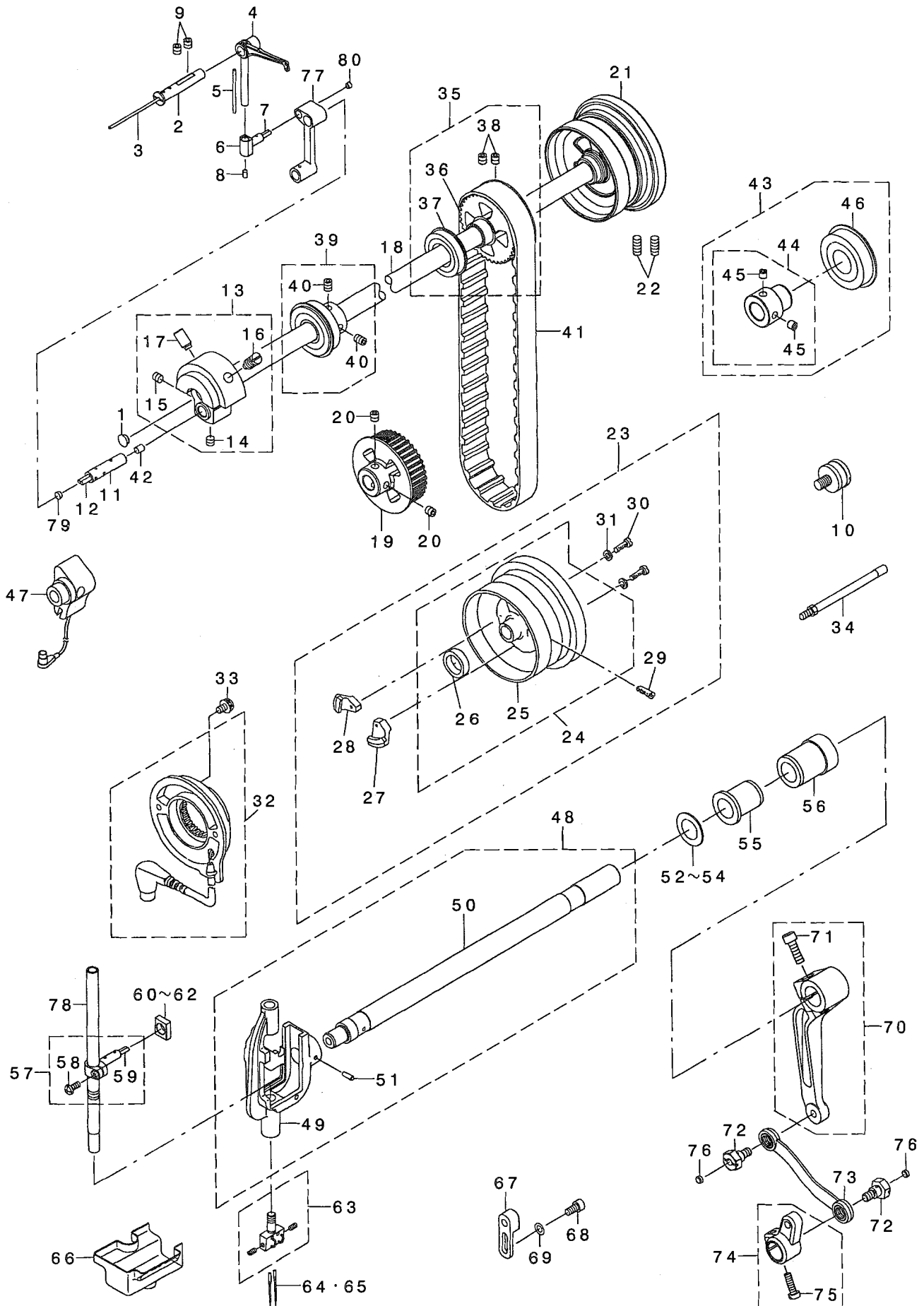

REF. NO	NOTE	PART NO.	DESCRIPTION	品名	Qty
1		TA-0750404-RO	PLUG D=7.5 L=3.5	トメシ D=7.5 L=3.5	1
2		226-05307	THREAD TAKE-UP LEVER PIN	デンビノチチエシク	1
3		CQ-2020000-00	OIL WICK	ユシ	0.15
4		400-24093	THREAD TAKE_UP_LEVER_C	デンビノC	1
5		CQ-2020000-00	OIL WICK	ユシ	0.04
6		400-22678	TAKE_UP_LEVER_THRUST_PIN	デンビノスラストシク	1
7		CQ-2520000-00	OIL WICK	ユシ	0.02
8		228-10907	RUBBER PLUG	デンビノコメシ	1
9		SM-8060612-TP	SCREW M6 L=6	トメネシ M6 L=6	2
10	04	226-22401	SYNCR0 FRNGE	シンクロフレンジ	1
11	*	400-29964	NEEDLE BAR CRANK PIN	ハリネウクランクピン	1
12		CQ-3030000-00	OIL WICK	ユシ	0.02
13		400-31864	ASSY COUNTER_WEIGHT	ツリアイスクミ	1
14		SM-8060552-TP	SCREW M6 L=5	トメネシ	(1)
15		SM-8060612-TP	SCREW M6 L=6	トメネシ M6 L=6	(1)
16		400-04171	COUNTER_WEIGHT_SCREW	ツリアイスクミネシ	(1)
17		SM-8081652-TP	SCREW M8 L=16	トメネシ M8 L=16	(1)
18		400-24436	MAINSHAFT	ウツク	1
19		400-28117	LOWER SPROCKET	ウツクノクサノロケツト	1
20		SM-8060612-TP	SCREW M6 L=6	トメネシ M6 L=6	2
21	01	400-32987	HAND WHEEL	ハズミク	1
22	01	SM-8061550-TP	SCREW M6 L=15	トメネシ M6 L=15	2
23	*02	400-32993	COMP_HAND_WHEEL_TRIM	ハズミクノホ(クミ)イトキリ	1
24		400-32994	ASSY_HAND_WHEEL_TRIM	ハズミクノマ(クツコ)ウイトキリ	(1)
25		400-27099	HAND WHEEL	ハズミク	(1)
26		M4002-110-000	GENERATOR ROTOR	ハツデノキロター	(1)
27		400-17624	MAGNET FITTING BASE A ASM.	マグネットトリツクダ イクツコウ	(1)
28		400-17625	MAGNET FITTING BASE B ASM.	マグネットトリツクダ イクツコウ	(1)
29	*	SM-8061612-TP	SCREW M6X16	トメネシ M6 L=16	(2)
30		SS-6111210-SP	SCREW 11/64-40 L=12	ヒラネシ 11/64-40 L=12	(2)
31		WP-0450801-SD	WASHER 4.5X10X0.8	ヒラネシノカネ 4.5X10X0.8	(2)
32		229-37965	DYNAMO STATOR	ハツデノキステーター(クミ)	1
33		SL-4051001-MZ	SCREW M5 L=9.6	チノカネキナハコネシ M5 L=9.6	2
34	04	400-32142	SENSOR_SUPPORT_SHAFT_ASM	ケンシユウキチエシク	1
35		400-29048	ASSY MAINSHAFT BEARING_2	ウツクノクサハノアソクノクミ	1
36		400-28116	MAIN_SHAFT_SPROCKET	ウツクノクサノロケツト	(1)
37		SB-1200025-00	BEARING	コロカノリツク	(1)
38		SM-8060612-TP	SCREW M6 L=6	トメネシ M6 L=6	(2)
39		400-29047	ASSY MAINSHAFT BEARING	ウツクノクサハノアソクノクミ	1
40		SM-8060612-TP	SCREW M6 L=6	トメネシ M6 L=6	(2)
41		400-28652	TIMING BELT	タイミンクノベルト	1
42		TA-0490601-RO	PLUG D=4.9X5.5 L=6	トメシ D=4.9X5.5 L=6	1
43		400-29049	ASSY MAINSHAFT BEARING_3	ウツクノクサハノアソクノクミ	1
44		400-33667	BEARING_BUSH_C_ASM	ベアリングノブッシュノクミ	(1)
45		SM-8060812-TP	SCREW M6 L=8	トメネシ M6 L=8	(2)
46		SB-1200002-00	BEARING_20X42	ベアリング 20X42	(1)
47	04	400-26920	SYNCHRONIZER ASM	シンクロクミ	1
48		400-26395	NEEDLE BAR ROCKING_BASE_ASM	ハリネウツクノウタノイクミ	1
49		400-26394	NEEDLE BAR ROCKING_BASE	ハリネウツクノウタノイクタハリナシ	(1)
50		400-25329	NEEDLE BAR SHAFT	ハリネウツクノウツク	(1)
51		PT-0502700-S0	TAPERED PIN	テーパードピン	(1)
52	03	B1438-512-A00	WASHER T=1.35	ヨトノシノクミノカネ T=1.35	1
53	03	B1438-512-B00	WASHER 17.1X28X1.5	ヨトノシノクミノカネ T=1.5	1
54	03	B1438-512-C00	WASHER	ヨトノシノクミノカネ	1
55		400-23568	BUSHING	ユツトノウマエタ	1
56		400-23569	BUSHING	ユツトノウツクノマタ	1
57		400-31862	ASSY NEEDLE BAR CONNECTION	ハリネウタノキクミ	1
58		SM-4041055-SP	SCREW	ナハネシ M4 L=10	(1)
59		CQ-2520000-00	OIL WICK	ユシ	(0.04)
60	03	232-04506	ROCKING ROD SQUARE BLOCK A	ハリネウクランクノツクノカクノVA	1
61	03	232-04605	ROCKING ROD SQUARE BLOCK B	ハリネウクランクノツクノカクノVB	1
62	03	232-04704	ROCKING ROD SQUARE BLOCK C	ハリネウクランクノツクノカクノVC	1
63	05	400-26035	ASSY_NEEDLE_CLAMP(1/4)	ハリネウメクミ(1/4)	1
64☆	03	MDP-500B1400	NEEDLE DPX5 #14	ハリDPX5 #14	2
65☆	03	MDP-170B2100	NEEDLE DPX17 #21	ハリDPX17 #21	2
66		226-06800	OIL GUARD RUBBER	ユツトノウツクノカネ(カサハノリナシ)	1
67	01	400-28666	ROCKING ROD FIXING_BLOCK	コテイトノタイ	1
68	01	SM-6051002-TP	SCREW M5X0.8 L=10	ロツクノカネノカネ M5X0.8 L=10	1
69	01	WP-0550800-SP	WASHER 5.5X10X0.8	ヒラネシノカネ 5.5X10X0.8	1
70		400-33669	ASSY REAR ARM	ハリネウツクノウツクノウツクノクミ	1
71		SM-6061802-TP	SCREW M6 L=18	ロツクノカネノカネ	(1)
72		400-26482	SHOULDER SCREW	ダノネシ	2
73		400-32124	DRIVING ROD ASM	ハリネウツクノウツクノクミ	1
74		400-28853	ASSY DRIVING ARM	ハリネウツクノウツクノウツクノクミ	1
75		SM-6051600-SP	SCREW M5 L=16	ヒラネシ M5 L=16	(1)
76		131-02702	THROAT PLATE COVER	ハリイタフタ	2
77		400-30037	NEEDLE BAR CRANK ROD	ハリネウクランクノツク	1
78		400-28031	NEEDLE BAR	ハリネウ	1
79	*	TA-0500301-RO	PLUG 5X5.8 L=3	トメシ 5X5.8 L=3	1
80	*	TA-0370301-RO	PLUG D=3.7X4.4 L=3	トメシ D=3.7X4.4 L=3	1
		NOTE (注記)	01...FOR LH-3528	LH-3528用	
			02...FOR LH-3528-7	LH-3528-7用	
			03...SELECTIVE PARTS	選択部品	
			04...OPTIONAL PARTS(FOR LH-3528)	オプション部品(LH-3528用)	
			05...EXCHANGING GAUGE PARTS	交換ゲージ部品	
			(SEE.P.30,31)	(30,31ページをご参照下さい。)	

4. HOOK & HOOK DRIVING SHAFT COMPONENTS

釜・下軸関係

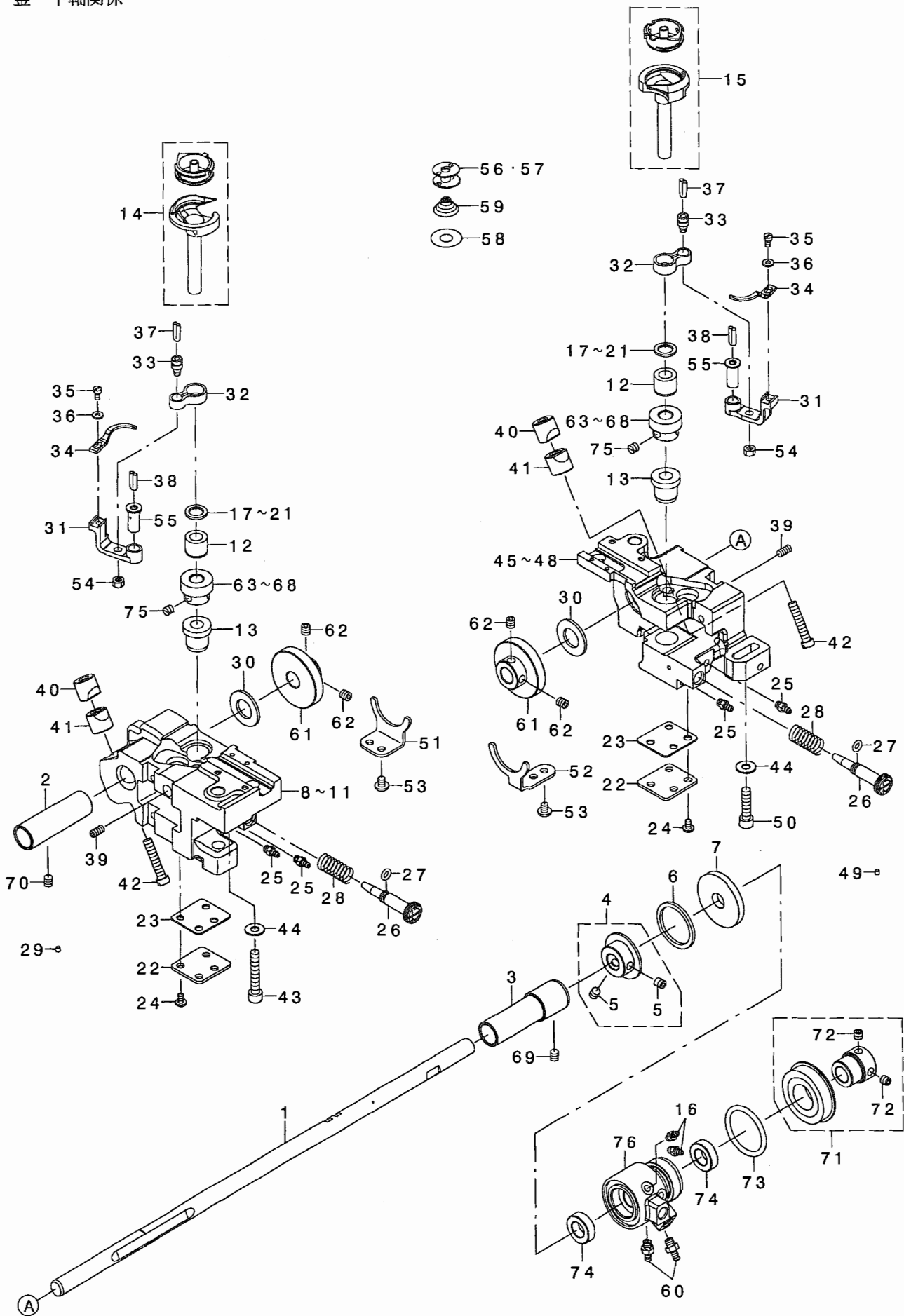

REF. NO	NOTE	PART NO.	DESCRIPTION	品名	Qty
1		400-28271	LOWER SHAFT	シモン ク	1
2		400-28851	LOWER SHAFT_BUSH-F	シモン クマメタル	1
3		400-30915	LOWER SHAFT_BUSH-M	シモン クナメタル	1
4		400-31351	ASSY-LOWER SHAFT_COLLAR	シモン クスラストカマ(クミ)	1
5		SM-8060612-TP	SCREW M6 L=6	トメネジ M6 L=6	(2)
6		400-13061	THRUST WASHER	スラストワシ ガネ	1
7		236-18804	OIL SEAL	シ ヨウガ オイルシ ヨウロオイルシ-ル	1
8	01	400-28485	HOOK_SHAFT_BASE-L	カマシ クダ イ(ヒダリ)	1
9	02	400-28487	HOOK_SHAFT_BASE-L-TRIM	イトキリカマシ クダ イ(ヒダリ)	1
10	03	400-34969	HOOK_SHAFT_BASE L	カマシ クダ イ(ヒダリ)コガ マ	1
11	04	400-34971	HOOK_SHAFT_BASE L-TRIM	イトキリカマシ クダ イ(ヒダリ)コガ マ	1
12	*	400-42121	HOOK_UPPER_BUSH	カマシ クウメタル	2
13		400-28491	HOOK_LOWER_BUSH	カマシ クウメタル	2
14☆	06	400-36682	ASSY-RATCH_HOOK	ラッチカマ(クミ)	2
15☆	07	400-36683	ASSY-RATCH_HOOK TRIM	イトキリラッチカマ(クミ)	2
16		SQ-2050453-MZ	CONNECTING SCREW	ハ イア レンクワネジ	2
17	*05	226-14002	THRUST WASHER, A	カマシ クシ ヨウメタルスハ-チ A	2
18	*05	226-14101	THRUST WASHER, B	カマシ クシ ヨウメタルスハ-チ B	2
19	*05	226-14200	SPACER, C	カマシ クシ ヨウメタルスハ-チ C	2
20	05	101-12605	THRUST WASHER 1.7	カマシ クウメタル スラストイタ 1.7	2
21	05	101-12704	THRUST WASHER 1.8	カマシ クウメタル スラストイタ 1.8	2
22		400-22589	BOTTOM COVER	カマシ クダ イフタ	2
23		400-22590	BOTTOM COVER_GASKET	カマシ クダ イハ ツキン	2
24	*	SM-4050855-SP	SCREW	ナメ ネジ M5 L=8	8
25		SQ-2050453-MZ	CONNECTING SCREW	ハ イア レンクワネジ	4
26		400-16748	OIL ADJUSTING SCREW	カマシヨウチヨウセツネジ	2
27		RO-0442401-00	RUBBER RING	Oリング	2
28		400-29570	OIL ADJUSTING_SPRING	ユリヨウチヨウセツハネ	2
29		TA-0290301-M0	PLUG	トメシ D=2.9X3.2 L=3	6
30		400-28494	GEAR THRUST SPACER	キ ヤスラストガネ	2
31		B1822-051-000	OPENING LEVER CRANK	ナカガ マアノイウチ	2
32	*	B1820-563-000	BOBBIN CASE OPENING LEVER LINK	ナカガ マアノイウチ	2
33	*	B1821-051-000	CRANK SCREW STUD	ナカガ マアノイウチクビ ツ	2
34		226-13509	BOBBIN CASE OPENING LEVER	ナカガ マアノイウチ(コガ マ)	2
35		SS-6090810-TP	SCREW 9/64-40 L=7.5	ヒラネジ 9/64-40 L=7.5	2
36		WP-0371016-SD	WASHER 3.7X8X1	ヒラシ ガネ 3.7X8X1	2
37		CQ-2020000-00	OIL WICK	ユシ	0.3
38		CQ-2020000-00	OIL WICK	ユシ	0.3
39		SM-8051002-TP	SCREW M5 L=10	トメネジ	2
40		101-09908	SADDLE INSTALLING BLOCK, UPPER	カマシ クダ イトメ ウエ	2
41		101-12407	SADDLE INSTALLING BLOCK, LOWER	カマシ クダ イトメ ウダ	2
42		SS-6153040-SP	SCREW 15/64-28 L=30	ヒラネジ 15/64-28 L=30	2
43		SM-6063502-TP	SCREW M6 L=35	ロツカクアノネ 1	1
44		WP-0621016-SD	WASHER 6.2X13X1	ヒラシ ガネ 6.2X13X1	2
45	01	400-28486	HOOK_SHAFT_BASE-R	カマシ クダ イ(ミキ)	1
46	02	400-28488	HOOK_SHAFT_BASE-R-TRIM	イトキリカマシ クダ イ(ミキ)	1
47	03	400-34970	HOOK_SHAFT_BASE R	カマシ クダ イ(ミキ)コガ マ	1
48	04	400-34972	HOOK_SHAFT_BASE_R-TRIM	イトキリカマシ クダ イ(ミキ)コガ マ	1
49		TA-0290301-M0	PLUG	トメシ D=2.9X3.2 L=3	6
50		SM-6062502-TP	SCREW M6 L=25	ロツカクアノネ 1	1
51		400-28495	GEAR GUIDE-L	キ ヤガ イト(ヒダリ)	1
52		400-28496	GEAR GUIDE-R	キ ヤガ イト(ミキ)	1
53		SM-4050655-SP	SCREW M5 L=6	ナメ ネジ M5 L=6	4
54	*	NS-6110420-SP	NUT 11/64-40	ロツカクナツ 11/64-40	2
55		B1823-051-000	OPENING LEVER CRANK PIN	ナカガ マアノイウチ シク	2
56☆	06	B9117-051-000	BOBBIN	ホ ビン	2
57☆	07	102-10805	HARD ALUMITE BOBBIN	コウツクアルミイト ホ ビン	2
58☆	07	226-53802	SHEET	クテシホ ウツシ-ト	2
59☆	07	101-11508	SPRING	クテシホ-ツハネ	2
60		SQ-2060451-MZ	CONNECTING SCREW	ハ イア レンクワネジ	2
61		400-28489	LOWER SHAFT GEAR	シモン クキヤ	2
62		SM-8060612-TP	SCREW M6 L=6	トメネジ M6 L=6	4
63	05	400-28560	HOOK_SHAFT_GEAR-A	カマシ クネジ ハグ ルマA	2
64	05	400-28561	HOOK_SHAFT_GEAR-B	カマシ クネジ ハグ ルマB	2
65	05	400-28562	HOOK_SHAFT_GEAR-C	カマシ クネジ ハグ ルマC	2
66	05	400-28563	HOOK_SHAFT_GEAR-D	カマシ クネジ ハグ ルマD	2
67	*05	400-40549	HOOK_SHAFT_GEAR-E	カマシ クネジ ハグ ルマE	2
68	*05	400-40550	HOOK_SHAFT_GEAR-F	カマシ クネジ ハグ ルマF	2
69		SM-8060612-TP	SCREW M6 L=6	トメネジ M6 L=6	1
70		SM-8060612-TP	SCREW M6 L=6	トメネジ M6 L=6	1
71		400-28656	ASSY-LOWER SHAFT BEARING	シモン クハ アリツケ(クミ)	1
72		SM-8060612-TP	SCREW M6 L=6	トメネジ M6 L=6	(2)
73		RO-2573501-00	O-RING	Oリング	1
74		228-88507	OIL SEAL	オクシレハ-シ クオイルシ-ル	2
75		SM-8060550-TP	SCREW M6 L=4.5	トメネジ M6 L=4.5	6
76		400-11947	LOWER_PLUNGER_BUSH	シモン クア ランシ ヤメタル	1

NOTE (注記)		
01... FOR LH-3528(EXCEPT CHINA)		LH-3528 (中国を除く)
02... FOR LH-3528-7(EXCEPT CHINA)		LH-3528-7 (中国を除く)
03... FOR LH-3528(CHINA)		LH-3528 (中国)用
04... FOR LH-3528-7(CHINA)		LH-3528-7 (中国)用
05... SELECTIVE PARTS		選択部品
06... FOR LH-3528		LH-3528用
07... FOR LH-3528-7		LH-3528-7用

5. FEED MECHANISM COMPONENTS

送り関係

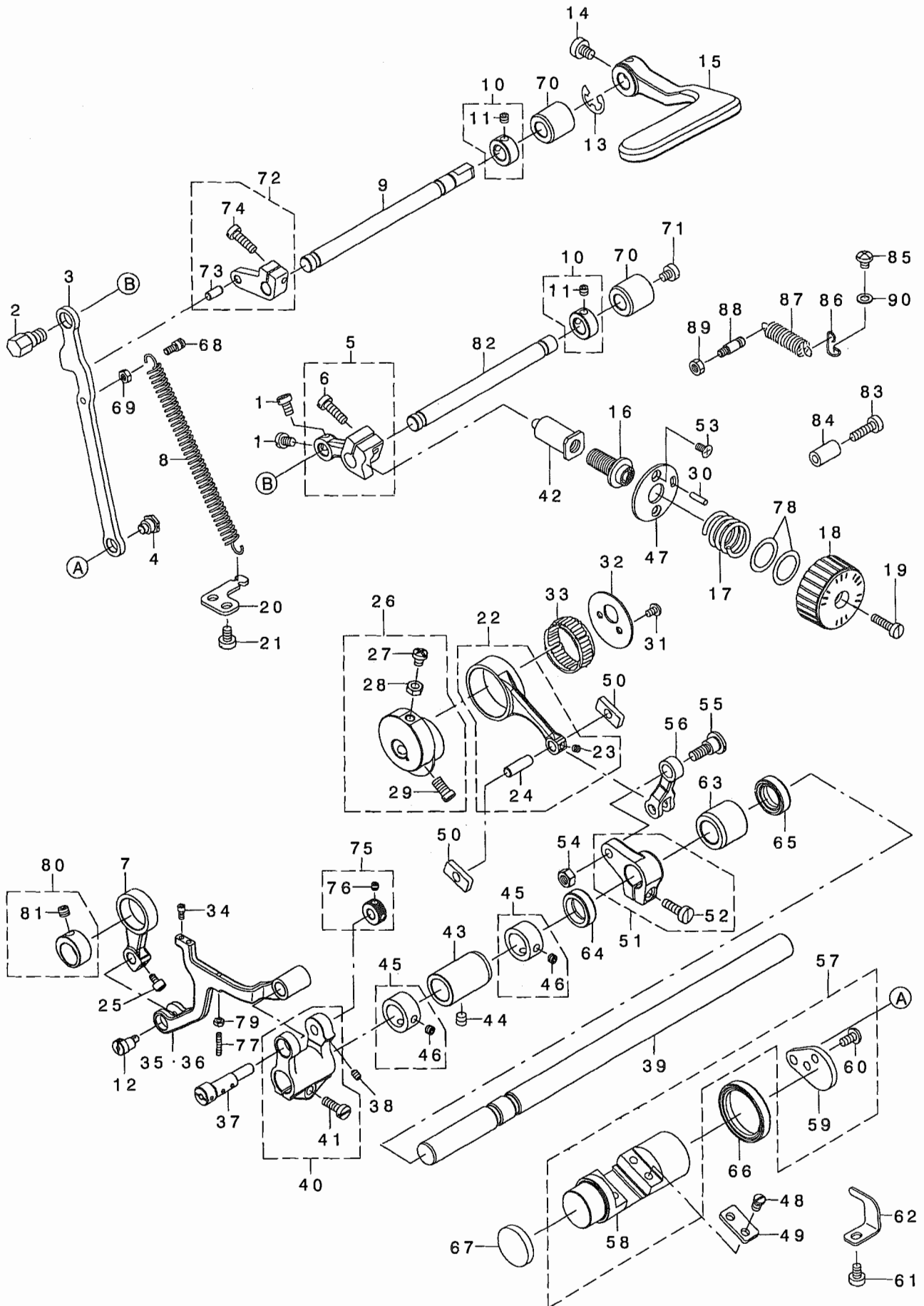

REF. NO	NOTE	PART NO.	DESCRIPTION	ヒソメイ	Qty
1		SM-6050800-SP	SCREW M5 L=8	ヒソメイ M5 L=8	2
2		400-28293	FEED REGULATOR ROD_PIN	ネクリヨウセツダ'ヒソ	1
3		400-28284	FEED REGULATOR ROD	ネクリヨウセツダ'ロッド	1
4		SD-0900426-TP	SHOULDER SCREW D=9 H=4.2	ダ'ソネ' D=9 H=4.2	1
5		400-28854	ASSY FEED REGULATOR	ネクリヨウセツダ'イグミ	1
6		SM-6051600-SP	SCREW M5 L=16	ヒソメイ M5 L=16	(1)
7		400-11935	VERTICAL FEED LINK	ソ'ヨウケ'ネクリリンク	1
8		226-10307	FEED REGULATOR SPRING	ネクリヨウセツダ'イハ'ネ	1
9		400-28286	REVERSE FEED SHAFT	キ'ヤクネクリレハ'-ソ'ク	1
10		400-32269	THRUST COLLAR	スラストカラー	1
11		SM-8050412-TP	SCREW M5 L=4	トメネイ M5 L=4	(2)
12		400-26673	VERTICAL_F_LINK_SHAFT_M	ソ'ヨウケ'ネクリリンク'クM	1
13	02	RE-0900000-KO	E-RING 9	E'ガ'タメウ 9	1
14	01	SM-6051000-SP	SCREW	ヒソメイ M5 L=10	1
15		400-33995	REVERSE FEED LEVER	キ'ヤクネクリレハ'-	1
16		235-33904	FEED ADJUSTING SCREW	ネクリヨウセツダ'イグミ	1
17		235-34506	FEED DIAL SPRING	ネクリタ'イヤルハ'ネ	1
18		400-36433	FEED DIAL	ネクリタ'イヤル	1
19		SS-6121860-SP	SCREW 3/16-28 L=18	ヒソメイ 3/16-28 L=18	1
20		400-29079	SPRING BRACKET	ハ'ネカク	1
21		SM-6050800-SP	SCREW M5 L=8	ヒソメイ M5 L=8	2
22		400-32293	ASSY FEED ROCKER ROD	スイハイネクリロッド'クミ	1
23		SM-8040412-TP	SET SCREW M4 L=4	トメネイ	(1)
24		B1653-470-000	PIN	カクゴ'マヒソ	(1)
25		SM-6750690-TP	SCREW M3.5 L=6	ロツカクナツ'ネ' M3.5 L=6	1
26		400-31348	ASSY FD ECCENTRIC_CAM	スイハイネクリカム(クミ)	1
27		SM-4051255-SP	SCREW M5 L=12.	ナ'ネイ M5 L=12	(1)
28		NM-6050001-SP	NUT M5	ロツカクナツ' M5X0.8 1ソ	(1)
29		SM-6061150-TP	SCREW M6 L=11	ヒソメイ M6 L=11	(2)
30		PS-0300122-KH	SPRING PIN 3X12	スプリング'ピン 3X12	1
31		SM-4040655-SP	SCREW M4 L=6	ナ'ネイ M4 L=6	2
32		400-11906	FD CAM L1D	スイハイネクリカム7タ	1
33	*	B1636-581-B00	NEEDLE BEARING B	ニ-ト'ル'ハ'アリソ' B	1
34		SM-6030672-TP	SCREW M3 L=6	ロツカクナツ'ネ' M3 L=6	2
35	01	400-11946	FEED BASE	ネクリタ'イ(イトキリソ)	1
36	02	400-11934	FEED BASE TRIM	ネクリタ'イ(イトキリ)	1
37		400-11932	FEED BASE SHAFT	ネクリタ'イ'ク	1
38		SM-8040612-TP	SCREW M4 L=6	トメネイ M4 L=6	1
39		400-28279	FEED ROCKER SHAFT	スイハイネクリソ'ク	1
40		400-31349	ASSY FEED BASE_ARM	ネクリタ'イウ' (クミ)	1
41		SM-6051400-SP	SCREW	ヒソメイ	(1)
42		235-33805	FEED ADJUSTING SHAFT	ネクリヨウセツダ'クメタル	1
43		400-11939	FEED SHAFT_BUSH_F	スイハイネクリソ'ク'クマエメタル	1
44		SM-8060612-TP	SCREW M6 L=6	トメネイ M6 L=6	1
45		400-32268	THRUST COLLAR	スラストカラー	2
46		SM-8050412-TP	SCREW M5 L=4	トメネイ M5 L=4	(2)
47		235-34019	FEED ADJUSTING BASE	ネクリヨウセツダ'イ	4
48		SM-7050850-TP	SCREW M5 L=8	マ'ヒソメイ M5 L=8	1
49		400-28277	FEED ADJUSTING_PLATE	ネクリヨウセツダ'イ'フタ	2
50		400-35704	FEED ADJUSTING_BLOCK	ネクリヨウセツダ'イ'ク'クマ	2
51		400-28852	ASSY FEED ROCKER_ARM	スイハイネクリソ'ク'クミ	1
52		SM-6051600-SP	SCREW M5 L=16	ヒソメイ M5 L=16	(1)
53		SM-2040750-TP	SCREW M4 L=7.4	マ'ヒソメイ M4 L=7.4	2
54		NM-6060001-CP	NUT M6	ロツカクナツ' M6	1
55		SD-0900706-TP	SHOULDER SCREW D=9 H=7	ダ'ソネ' D=9 H=7	1
56		400-36679	FEED_RUCKER_ARM_ROD	スイハイネクリソ'ク'クマ	1
57		400-28274	ASSY FEED ADJUSTING	ネクリヨウセツダ'イ'クミ	1
58		400-28275	FEED ADJUSTING	ネクリヨウセツダ'イ	(1)
59		400-28276	FEED ADJUSTING_ARM	ネクリヨウセツダ'イ'ウ'	(1)
60	*	SM-4051055-SP	SCREW	ナ'ネイ	(2)
61		SM-6050800-SP	SCREW M5 L=8	ヒソメイ M5 L=8	1
62		400-28281	FEED ADJUSTING STOPPER	ネクリヨウセツダ'イ'ウ'ク'イタ	1
63		400-28280	FEED SHAFT_BUSH_R	スイハイネクリソ'ク'ク'ク'ロメタル	1
64		400-13362	FEED SHAFT_OIL_SEAL_A	スイハイネクリソ'ク'ク'ク'ク'ル	1
65		400-25316	FEED SHAFT_OIL_SEAL_B	ネクリソ'ク'ク'ク'ク'ルB	1
66		400-28291	FEED ADJUSTING_OIL_SEAL	ネクリヨウセツダ'イ'ク'ク'ル	1
67		400-28294	FEED ADJUSTING_CAP	ネクリヨウセツダ'イ'ク'ク'フタ	1
68		400-11926	SPRING HOOK	ハ'ネカク	1
69		NM-6040001-SP	NUT M4X0.7	ロツカクナツ' M4X0.7 1ソ	1
70		400-28287	REVERSE FEED SHAFT_BUSH	キ'ヤクネクリレハ'-ソ'ク'クメタル	2
71		SM-6050650-TP	SCREW M5 L=6	ヒソメイ M5 L=6	1
72		400-28855	ASSY REVERSE FEED ARM	キ'ヤクネクリレハ'-ウ'ク'クミ	1
73		133-19405	MAIN FEED ROCKER PIN	キ'ヤクネクリレハ'-ウ'ク'ヒソ	(1)
74		SM-6051600-SP	SCREW M5 L=16	ヒソメイ M5 L=16	(1)
75		400-31350	ASSY FEED BASE SHAFT COLLAR	ネクリタ'イ'ク'ク'スラストウ'ク(クミ)	1
76		SM-8040412-TP	SET SCREW M4 L=4	トメネイ	(2)
77		SM-8031612-TP	SET SCREW M3X16	トメネイ	1
78	*	WP-1751616-SD	WASHER 17.5X24X1.6	ヒソイ'ガ'ネ 17.5X24X1.6	2
79		NM-6030001-SN	NUT	ロツカクナツ'	1
80		400-33668	ASSY VERTICAL FEED CAM	ソ'ヨウケ'ネクリカムクミ	1
81		SM-8060552-TP	SCREW M6 L=5	トメネイ	(1)
82		400-28285	FEED REGULATOR_SHAFT	ネクリヨウセツダ'イ'ク	1
83	*	SM-6051850-TP	SCREW M5 L=18	ヒソメイ M5 L=18	1
84	*	229-52501	BACK LEVER STOPPER	ハ'ク'レハ'-ストッパ'-	1
85	*	SM-4050655-SP	SCREW M5 L=6	ナ'ネイ M5 L=6	1
86	*	226-56003	SPRING SUSPENSION	レハ'-ハ'ネカク	1
87	*	400-40924	SPRING	ネクリレハ'-モト'ソ'ハ'ネ	1
88	*	400-29257	SPRING_HOOK_B	ハ'ネカク B	1
89	*	NM-6050001-SP	NUT M5	ロツカクナツ' M5X0.8 1ソ	1
90	*	WP-0520656-SA	WASHER 5.2X9.5X0.6	ヒソイ'ガ'ネ 5.2X9.5X0.6	1

NOTE (注記) 01.... FOR LH-3528
02.... FOR LH-3528-7

LH-3528用
LH-3528-7用

8. AUTOMATIC REVERSE FEED MECHANISM COMPONENTS

自動逆送り関係

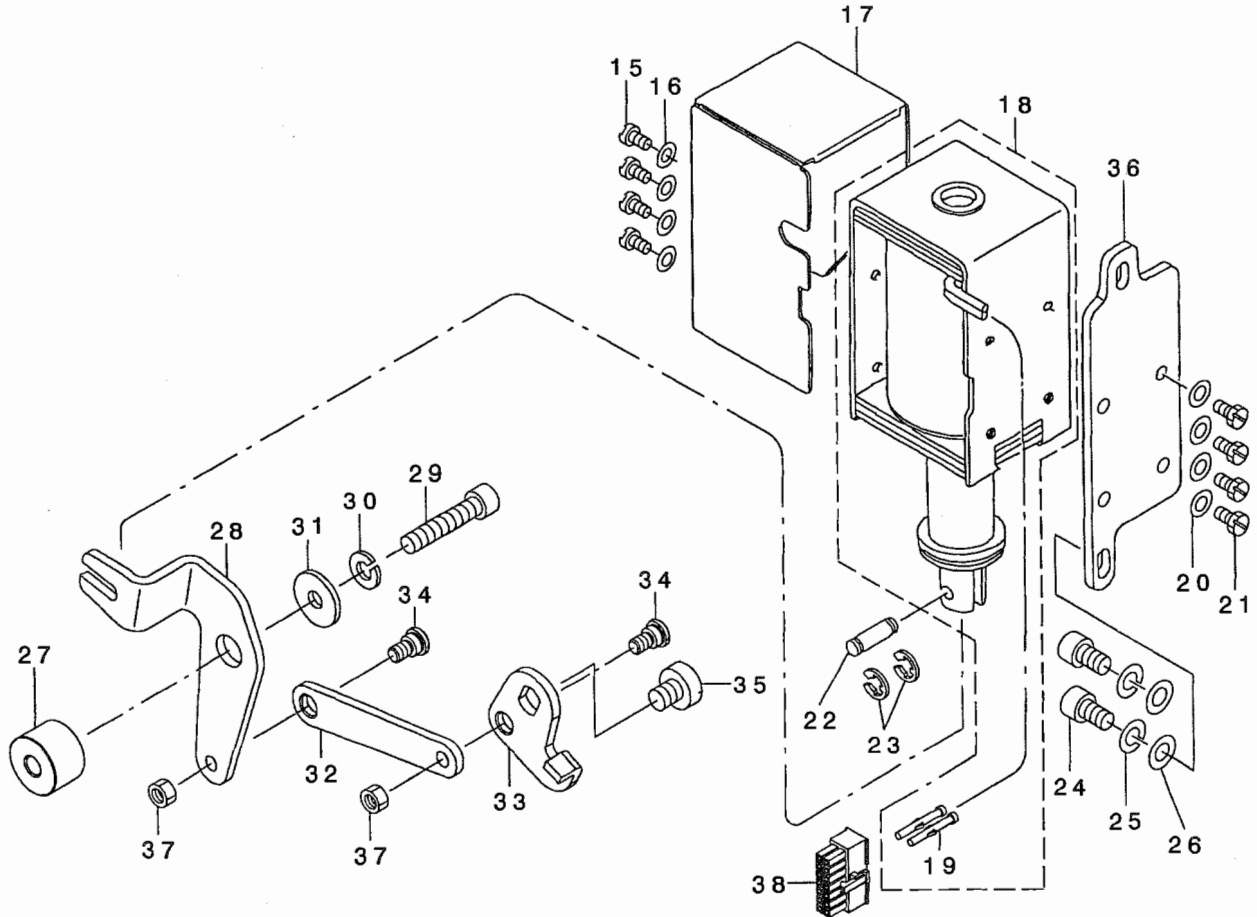
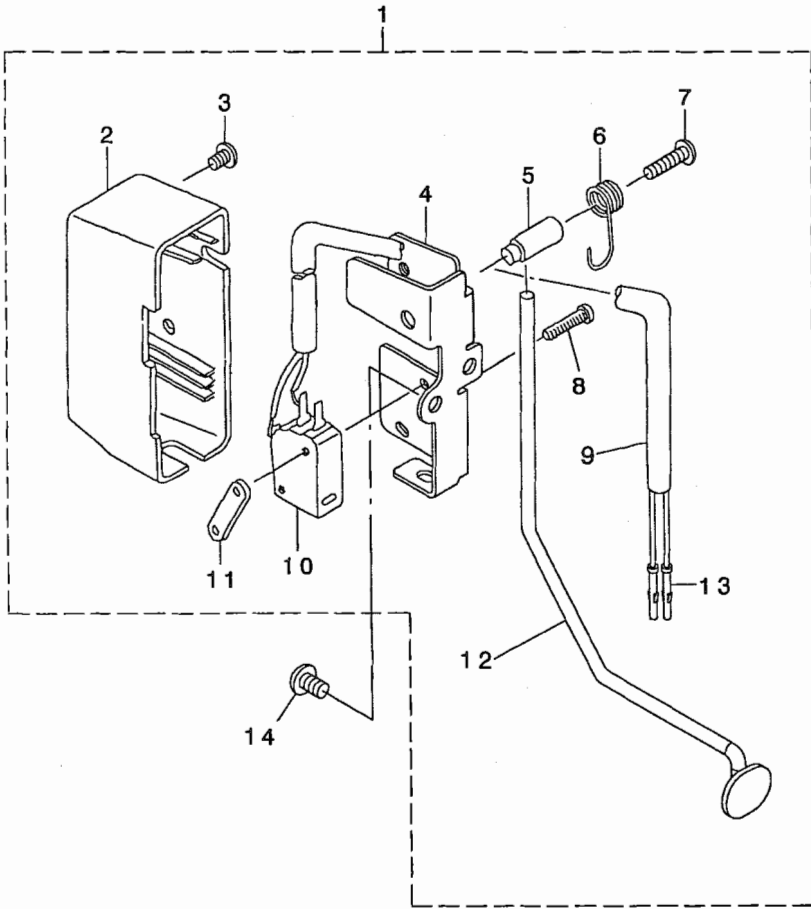

REF. NO	NOTE	PART NO.	DESCRIPTION	ヒソメイ	Qty
1		400-33408	ASSY_REVERSE_FEED_SWITCH_28	キヤクオクリスイッチ(クミ)28	1
2		229-54606	REVERSE_FEED_SWITCH_COVER	キヤクオクリスイッチカバー	(1)
3		SS-4110615-SP	SCREW 11/64-40 L=6	ナハコネシ 11/64-40 L=6	(1)
4		226-56508	REVERSE_FEED_SWITCH_BASE	シヤクオクリスイッチベース	(1)
5		229-54200	REVERSE_FEED_SWITCH_SHAFT	キヤクオクリスイッチシャフト	(1)
6		229-54309	REVERSE_FEED_SWITCH_SPRING	キヤクオクリスイッチバネ	(1)
7		SM-4041655-SP	SCREW M4 L=16	ナハネシ	(1)
8		SM-4031501-SC	SCREW M3 L=15	ナハコネシ M3 L=15	(2)
9		HW-5000700-00	2-CORE CABTYRE CORD	2芯シヤブタイコト	(1.2)
10		HA-0019000-00	MICROSWITCH	マイクロスイッチ	(1)
11		229-54408	STOPPER PLATE	キヤクオクリスイッチストッププレート	(1)
12		400-29027	REVERSE_FEED_SWITCH_LEVER	キヤクオクリスイッチレバー	(1)
13		HK-0346400-0B	PIN CONTACT	ピンコンタクト	(2)
14		SM-4050855-SP	SCREW	ナハネシ M5 L=8	2
15		SS-7110710-SP	SCREW 11/64-40 L=7	マルヒラネシ 11/64-40 L=7	4
16		WP-0501016-SD	WASHER 5X10.5X1	ヒラザカネ 5X10.5X1	4
17		101-61305	SOLENOID COVER	マグネットカバー	1
18		400-36360	REVERSE_FEED_SOLENOID	キヤクオクリソレノイド	1
19		HK-0346400-0B	PIN CONTACT	ピンコンタクト	(2)
20		WP-0501016-SD	WASHER 5X10.5X1	ヒラザカネ 5X10.5X1	4
21		SS-9111010-SP	SCREW 11/64-40 L=9.5	ロツカクネルト 11/64-40 L=9.5	4
22		D2464-555-B00	LINK DRIVING MAGNET PIN	マグネットリンクピン	1
23		RE-0400000-KO	E-RING 4	Eカクタメツ 4	2
24		SM-6061002-TP	SCREW M6 L=10	ロツカクアネルト M6 L=10	2
25		WS-0631510-KP	SPRING WASHER	ハネサカネ	2
26		WP-0621016-SD	WASHER 6.2X13X1	ヒラザカネ 6.2X13X1	2
27		400-30856	LINK_FULCULUM	リンクラテン	1
28		400-29350	REVERSE_FEED_LINK_L	キヤクオクリリンク	1
29		SM-6063002-TP	SCREW M6 L=30	ハンソウタイシクウケトメネシ	1
30		WS-0610002-KP	SPRING WASHER	ハネサカネ	1
31		WP-0612056-SD	WASHER 6.1X18.5X2	ヒラザカネ 6.1X18.5X2	1
32		400-35278	REVERSE_FEED_LINK_B	キヤクオクリリンク B	1
33		400-35277	REVERSE_FEED_LINK_A	キヤクオクリリンク A	1
34	*	SD-0700328-TP	SHOULDER SCREW D=7 H=3.2	ダンネシ D=7 H=3.2	2
35		SM-6050650-TP	SCREW M5 L=6	ヒラコネシ M5 L=6	1
36		101-19204	SOLENOID INSTALLING PLATE	マグネットトリツケダ	1
37		NM-6050001-SP	NUT M5	ロツカクナツト M5X0.8 1シユ	2
38		HK-0346101-40	HOUSING 14P	ハウジング 14P	1

9. WIPER MECHANISM COMPONENTS (FOR LH-3528-7)

ワイパー装置関係 (LH-3528-7用)

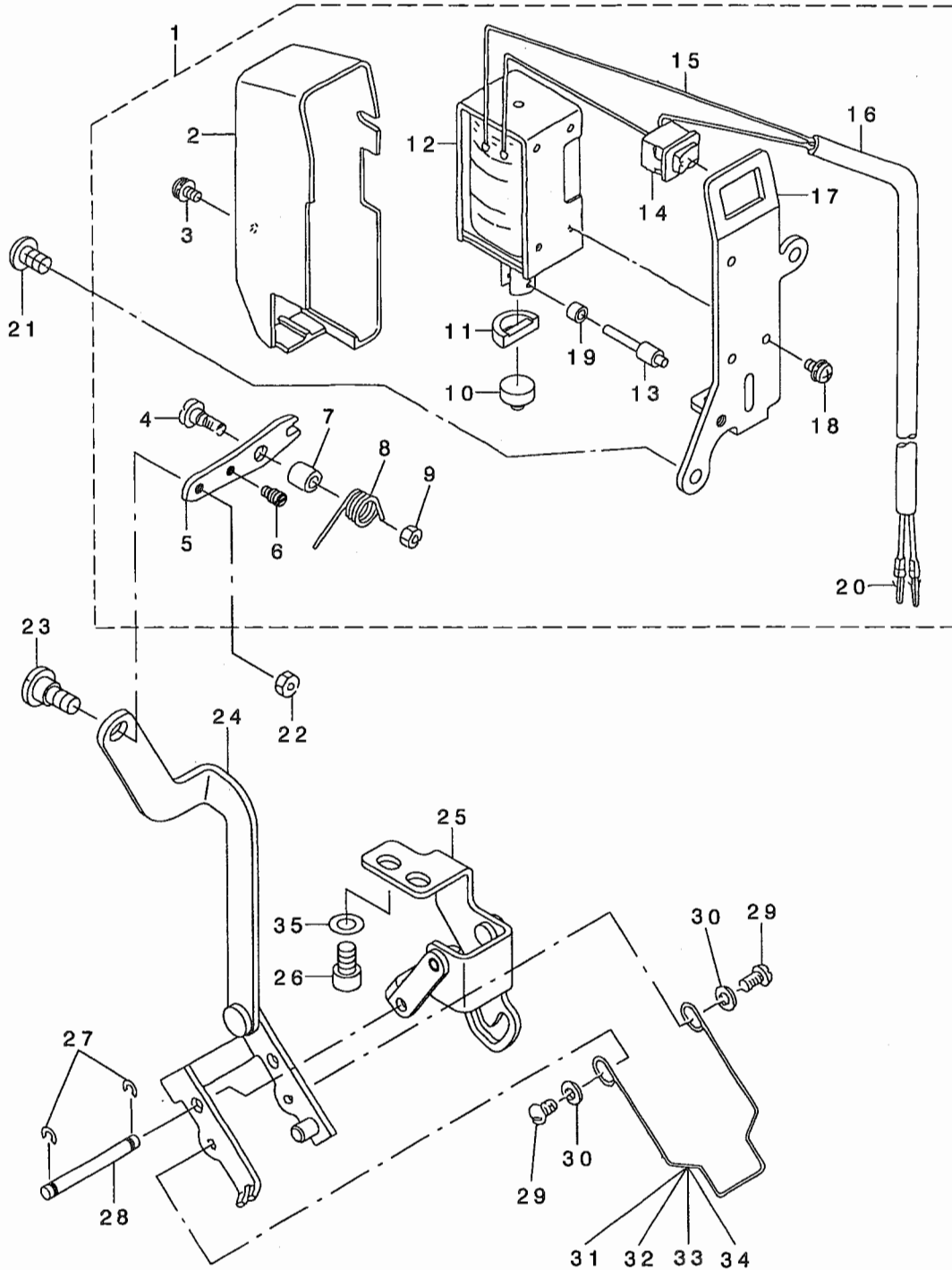

REF. NO	NOTE	PART NO.	DESCRIPTION	ヒョウメイ	Qty
1		400-33437	WIPER_SOLENOID_ASM	ワイパ-ソレノイドクミ	1
2		229-55504	WIPER COVER	ワイパ-カバー	(1)
3		SL-4030631-SC	SCREW M3X6	サカネツキナハコネシ M3 L=6	(1)
4		SD-0650321-TP	HINGE SCREW D=6.5 H=3.2	タソネシ D=6.5 H=3.2	(1)
5		226-57209	WIPER LINK, A	ワイパ-リンク A	(1)
6		400-09196	SUSPENSION SCREW	ウツキリハネカケ	(1)
7		229-56205	WIPER HINGE SCREW COLLAR	ワイパ-タソネシカラ-	(1)
8		226-57308	WIPER SPRING	ワイパ-ハネ	(1)
9		NS-6110310-SP	NUT 11/64-40	ロツカクナツト 11/64-40	(1)
10		229-55900	WIPER RUBBER A	ワイパ-ゴム A	(1)
11		229-56007	WIPER RUBBER B	ワイパ-ゴム B	(1)
12		400-30956	WIPER_SOLENOID	ワイパ-ソレノイド	(1)
13		229-57104	WIPER SOLENOID SHAFT	ワイパ-ソレノイドシク	(1)
14		HA-0005900-00	POWER SWITCH	テソグソスイツチ	(1)
15		HW-2003900-00	ELECTRIC WIRE	ヒニルテソセン 17-0.16 ヅロ	(0.04)
16		HW-5000700-00	2-CORE CABTYRE CORD	2ソソキアタイゴト	(1.04)
17		226-57100	WIPER SOLENOID BASE	ワイパ-ソレノイドタ	(1)
18	*	SL-4030641-SE	SCREW	サカネツキネシ	(3)
19		229-57203	WIPER LINK COLLAR	ワイパ-リンクカラ-	(1)
20		HK-0346400-0B	PIN CONTACT	ヒソソコタクト	(2)
21		SM-4050855-SP	SCREW	ナハネシ M5 L=8	2
22		NS-6090310-SP	NUT 9/64-40	ロツカクナツト 9/64-40	1
23		SD-0500301-SP	HINGE SCREW D= 5 H= 3	タソネシ D=5 H=3	1
24		400-28797	ASSY WIPER_LINK_2	ワイパ-リンククミ2	1
25		400-28799	ASSY WIPER_BASE	ワイパ-トタイクミ	1
26		SM-6050802-TP	SCREW M5X0.8 L=8	ロツカクナツト M5X0.7 L=8	2
27		RE-0320000-KO	E-RING 3.2	Eカトメワ 3.2	2
28		102-08700	WIPER LINK SHAFT	ワイパ-リンクシク	1
29		SS-3090520-SP	SCREW 9/64-40 L=4.5	マルネシ 9/64-40 L=4.5	2
30		WP-0371016-SD	WASHER 3.7X8X1	ヒラサカネ 3.7X8X1	2
31	01	102-09203	WIPER 3/32"-3/8"	ワイパ-	1
32	01	102-09500	WIPER	ワイパ-	1
33	01	102-09807	WIPER	ワイパ-	1
34	01	102-09906	WIPER	ワイパ-	1
35	*	WP-0531000-SD	WASHER M5	ヒラサカネコカタマル M5	2

NOTE (注記) 01....SELECTIVE PARTS

選択部品

10. LUBRICATION COMPONENTS

給油関係

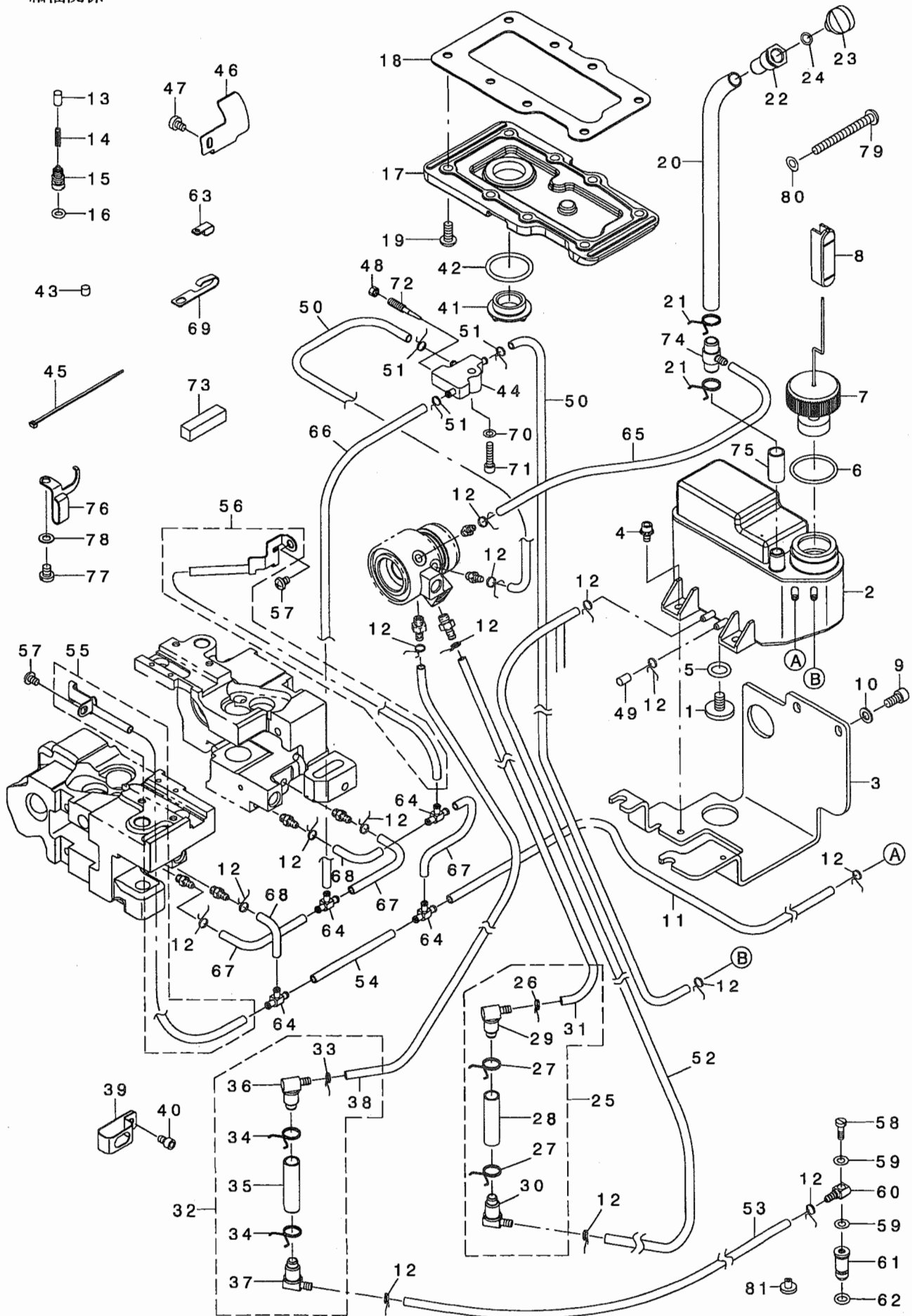

REF. NO	NOTE	PART NO.	DESCRIPTION	品名	Qty
1		400-28689	SCREW	ネジ	1
2		400-34926	OIL TANK ASM.	オイルタンクミ	1
3		400-34649	OIL TANK PLATE	オイルタンクトリツガイ	1
4		SL-6040892-TN	BOLT	ボルト	2
5		RO-0982401-00	RUBBER RING	Oリング	1
6		RO-2192001-00	RUBBER RING	Oリング	1
7		400-28705	ASSY FLOATER	フローター	1
8		400-36167	OIL GAGE	オイルゲージ	1
9		SM-6051002-TP	SCREW M5X0.8 L=10	ロツカクアナボルト M5X0.8 L=10	2
10		WP-0550800-SP	WASHER 5.5X10X0.8	ワシヤ	2
11		236-30007	TUBE	チューブ	0.48
12		236-29306	PIPE STOPPER A	パイプストッパ A	15
13		236-28803	PLUNGER	プランジャ	2
14		236-28902	PLUNGER SPRING	プランジャスプリング	2
15		400-13509	PLUNGER SCREW	プランジャネジ	2
16		RO-0481901-00	RUBBER RING	Oリング	2
17		400-28773	BOX COVER	ボックスフタ	1
18		400-28774	BOX COVER PACKING	ボックスフタパッキン	1
19		SM-4051255-SP	SCREW ,M5 L=12	ナメネジ M5 L=12	8
20		236-30106	TUBE B	チューブ B	0.2
21		236-29405	PIPE STOPPER B	パイプストッパ B	2
22		400-29075	LUBRICATING INLET	キュウコウ	1
23		400-00344	LUBRICATING INLET CAP	キュウコウキャップ	1
24		RO-0481901-00	RUBBER RING	Oリング	1
25		400-22449	SUB ASSY OIL FILTER_S	オイルフィルタークミS	1
26		236-29306	PIPE STOPPER A	パイプストッパ A	(1)
27		236-29405	PIPE STOPPER B	パイプストッパ B	(2)
28		236-30106	TUBE B	チューブ B	(0.04)
29		236-30650	OIL FILTER JOINT ASM.	オイルフィルタージョイント(クミ)	(1)
30		236-30601	OIL FILTER JOINT	オイルフィルタージョイント	(1)
31		236-30007	TUBE	チューブ	(0.05)
32		400-22450	SUB ASSY OIL FILTER_L	オイルフィルタークミL	1
33		236-29306	PIPE STOPPER A	パイプストッパ A	(1)
34		236-29405	PIPE STOPPER B	パイプストッパ B	(2)
35		236-30106	TUBE B	チューブ B	(0.05)
36		236-30650	OIL FILTER JOINT ASM.	オイルフィルタージョイント(クミ)	(1)
37		236-30601	OIL FILTER JOINT	オイルフィルタージョイント	(1)
38		236-30007	TUBE	チューブ	(0.06)
39		400-16749	TUBE HOLDER	パイプホルダ	1
40		SM-6040602-TP	SCREW M4 L=6	ロツカクアナボルト M4X0.7 L=6	1
41		400-34246	OIL SIGHT WINDOW	オイルラジウキマド	1
42		RO-1952401-00	RUBBER RING	Oリング	1
43		B3517-009-000	OIL FELT REAR	オイルフェルト	1
44		400-32804	BASE	ベース	1
45		EA-9500B01-00	CABLE BAND	ケーブルバンド	3
46	*	400-39604	LUBRICATING GUIDE	オイルキュウコウガイド	1
47		SM-6040650-TP	SCREW	ワシヤ	1
48		NS-6110310-SP	NUT 11/64-40	ロツカクナツト 11/64-40	1
49		235-40305	FLOATER CASE CAP	フローターケースキャップ	1
50		236-30007	TUBE	チューブ	0.23
51	*	101-26803	OIL TUBE HOLDER	パイプホルダ	3
52		236-30007	TUBE	チューブ	0.2
53		236-30007	TUBE	チューブ	0.38
54		236-30007	TUBE	チューブ	0.07
55		400-32405	ASSY GEAR OIL WICK LEFT	ギヤキュウコウオイルソクミヒダリ	1
56		400-32406	ASSY GEAR OIL WICK RIGHT	ギヤキュウコウオイルソクミヒダリ	1
57		SM-4050655-SP	SCREW M5 L=6	ナメネジ M5 L=6	2
58		B3525-357-000	CONNECTING SCREW (B)	連結ネジ B	1
59		B3534-012-000	GASKET	パッキン	2
60		SQ-0000401-MZ	CONNECTING SCREW	チューブ連結ネジ	1
61		400-36333	SUCTION	キュウコウ	1
62		RO-0371801-00	RUBBER RING	Oリング	1
63		D2112-555-B00	CORD HOLDER, LARGE	コードホルダ A	1
64		137-65607	OIL CONNEC. ARM	キュウコウ連結アーム	4
65		236-30007	TUBE	チューブ	0.28
66		236-30007	TUBE	チューブ	0.33
67		236-30007	TUBE	チューブ	0.06
68		236-30007	TUBE	チューブ	0.03
69		262-30409	LUBRICATING OIL WICK STOPPER	キュウコウソクミ	1
70		WP-0430800-SD	WASHER M4	ワシヤ	1
71		SM-6041602-TP	SCREW M4X0.7 L=16	ロツカクアナボルト M4X0.7 L=16	1
72		B1834-512-000	OIL ADJUSTING SCREW	オイル調整ネジ	1
73	*	226-03708	FELT	フェルト	1
74	*	400-40809	OIL JOINT	オイルジョイント	1
75	*	236-30106	TUBE B	チューブ B	0.02
76	*	400-35264	SPRING HOOK	スプリングフック	1
77	*	SM-4050655-SP	SCREW M5 L=6	ナメネジ M5 L=6	1
78	*	WP-0520656-SA	WASHER 5.2X9.5X0.6	ワシヤ	1
79	*	SM-4055001-SF	SCREW M5 L=50	ナメネジ M5X0.8 L=50	1
80	*	WP-0531000-SD	WASHER M5	ワシヤ	1
81	*	400-42086	CAP	キャップ	1

11. BELT COVER & BOBBIN WINDER COMPONENTS

ベルトカバー・糸巻き装置関係

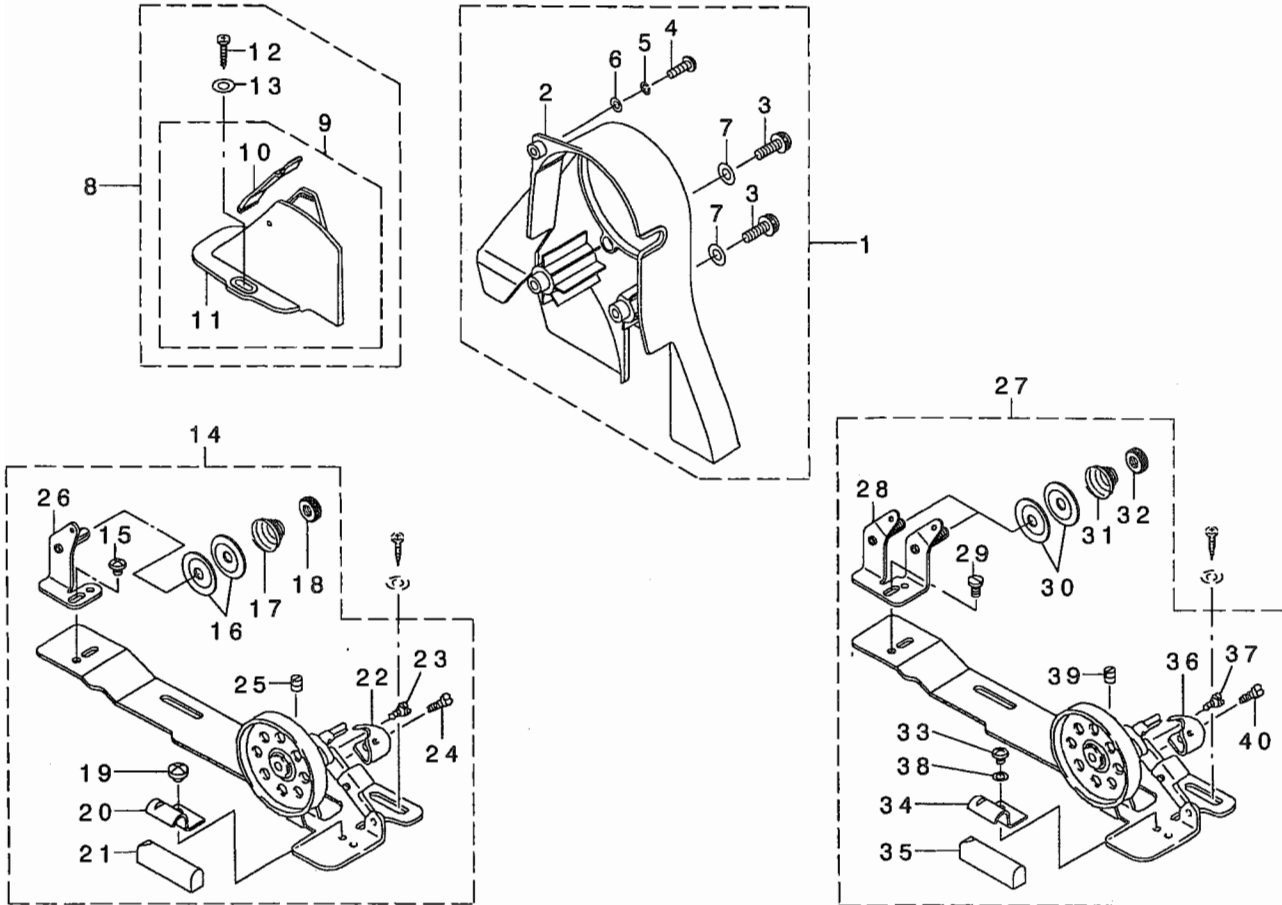

REF. NO	NOTE	PART NO.	DESCRIPTION	ヒソメイ	Qty
1		400-33409	ASSY BELT COVER	ベルトカバー-クミ	1
2		400-29905	BELT COVER A	ベルトカバー-A	(1)
3	*	SM-4062001-SC	SCREW M6 L=20	ナメコネツ M6 L=20	(2)
4		SM-4051601-SC	SCREW M5X0.8 L=16	ナメコネツ M5X0.8 L=16	(1)
5		WS-0521010-KN	SPRING WASHER 5.2X8.2X1	ハネネツ ガネ 5.2X8.2X1	(1)
6		WP-0531001-SC	WASHER	ヒラツ ガネ ミガキマル M5	(1)
7	*	WP-0641600-SC	WASHER 6.4X12.5X1.6	ヒラツ ガネ	(2)
8		400-34267	ASSY BELT COVER B	ベルトカバー-Bクミ	1
9		229-33659	BELT COVER B COMPL.	ベルトカバー-B(クツコウ)	(1)
10		229-33758	BELT COVER B LID ASM.	ベルトカバー-Bフタ(クミ)	(1)
11		229-33600	BELT COVER B	ベルトカバー-B	(1)
12		SK-3412000-SC	WOOD SCREW D=4.1 L=20	マルヒラネツ D=4.1 L=20	(2)
13		WP-0501016-SC	WASHER 5X10.5X1	ヒラツ ガネ 5X10.5X1	(2)
14		229-27354	BOBBIN WINDER COMPL.	イトマキツウチ(クツコウ)	1
15		SS-4110515-SP	SCREW 11/64-40 L=5	ナメネツ 11/64-40 L=5	(1)
16		229-28907	THREAD TENSION DISK	イトチヨウツラ	(2)
17		229-29004	THREAD TENSION SPRING	イトチヨウツラ	(1)
18		229-28808	NUT	イトチヨウツラ	(1)
19		SS-7110350-SP	SCREW 11/64-40 L=3.5	ナメネツ 11/64-40 L=3.5	(1)
20		229-28402	CONTROL RUBBER HOLDING PLATE	セキヨコ ムネツエ	(1)
21		229-28303	CONTROL RUBBER	セキヨコ A	(1)
22		229-28105	BOBBIN PRESSER	ホビンオサエ	(1)
23		SD-0490261-SP	HINGE SCREW D=4.9 H=2.6	クツネツ D=4.9 H=2.6	(1)
24		SS-7081310-SP	SCREW 1/8-44 L=12.5	マルヒラネツ 1/8-44 L=12.5	(1)
25		SS-8110510-SP	SCREW 11/64-40 L=5	トメネツ 11/64-40 L=5	(1)
26		229-28501	THREAD TENSION POST BASE	イトマキイトチヨウツラ	(1)
27	01	226-21155	THREAD WINDER ASM.	イトマキツウチ(クツコウ)	1
28		226-21056	TENSION BAR BASE	イトマキイトチヨウツラ ムネツエ(クツコウ)	(1)
29		SS-7110840-SP	SCREW 11/64-40 L=7.8	マルヒラネツ 11/64-40 L=7.8	(1)
30		229-28907	THREAD TENSION DISK	イトチヨウツラ	(4)
31		229-29004	THREAD TENSION SPRING	イトチヨウツラ	(2)
32		229-28808	NUT	イトチヨウツラ	(2)
33		SS-4110515-SP	SCREW 11/64-40 L=5	ナメネツ 11/64-40 L=5	(1)
34		229-28402	CONTROL RUBBER HOLDING PLATE	セキヨコ ムネツエ	(1)
35		229-28303	CONTROL RUBBER	セキヨコ A	(1)
36		226-21106	BOBBIN PRESSER	ホビンオサエ	(1)
37		SD-0490261-SP	HINGE SCREW D=4.9 H=2.6	クツネツ D=4.9 H=2.6	(1)
38		WP-0480856-SP	WASHER 4.8X8.4X0.8	ヒラツ ガネ 4.8X8.4X0.8	(1)
39		SM-8040502-TP	SCREW M4X0.7 L=5	トメネツ M4X0.7 L=5	(1)
40		SS-7081310-SP	SCREW 1/8-44 L=12.5	マルヒラネツ 1/8-44 L=12.5	(1)

NOTE (注記)

01...FOR JE

JE用

12. BOTTOM COVER COMPONENTS

ボトムカバー関係

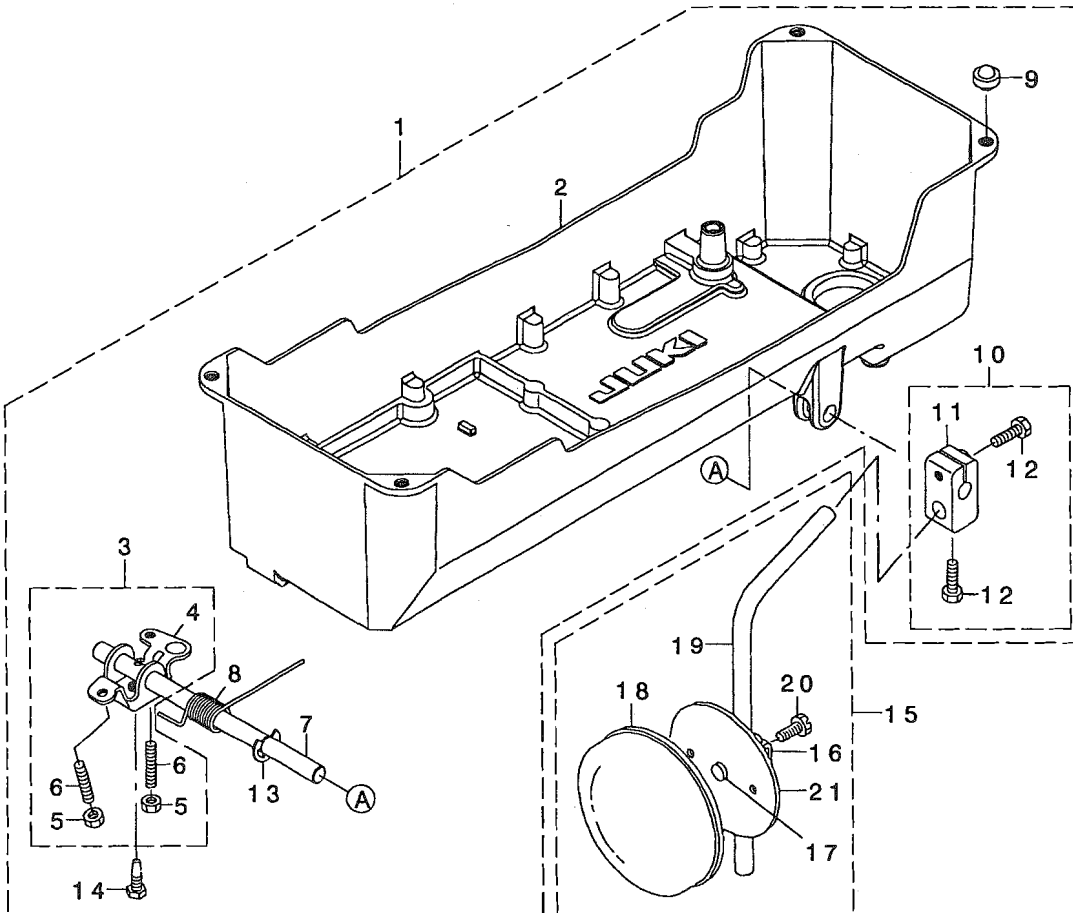

REF. NO	NOTE	PART NO.	DESCRIPTION	ヒョメイ	Qty
1		400-32107	ASSY_BOTTOM_COVER_A	ボトムカバー-Aクミ	1
2		400-28778	BOTTOM_COVER	ボトムカバー-	(1)
3		400-34853	CONNECTING_ROD_ASM	ヒサアケカイトンウテクミ	(1)
4		229-32107	KNEE_LIFTING_ROTATING_ARM	ヒサアケカイトンウテ	(1)
5		NM-6060001-SE	NUT M6	ロツカクナツト M6 1シユ	(2)
6		SM-8063012-TR	SCREW M6 L=30	トメネジ	(2)
7		400-25191	KNEE_PRESS_ROD	ヒサアテヨコシク	(1)
8		229-32206	SPRING	ヒサアケカイトンウテハネ	(1)
9		101-62600	RUBBER_CUSHION	トウフササエゴム	(4)
10		229-32453	BRACKET_ASM.	ヒサアテタテクトリツケウテ(クミ)	(1)
11		229-32404	BRACKET	ヒサアテタテクトリツケウテ	(1)
12		229-34707	SCREW	ヒサアテタテクトリツケウテシメネジ	(2)
13		RE-1000000-KO	E-RING 10	Eカタトメワ 10	(1)
14		SM-9061853-SR	SCREW M6 L=17.5	ロツカクホルト	(1)
15	01	229-34251	KNEE_PAD_PLATE_ASM.	ヒサアテイタ(クミ)	1
16		229-34301	KNEE_PAD_PLATE_SUPPORT	ヒサアテイタササエ	(1)
17		229-34400	KNEE_PAD_PLATE_RUBBER	ヒサアテイタゴム	(1)
18		229-34509	KNEE_PAD_PLATE_COVER	ヒサアテイタカハ-	(1)
19		229-34608	KNEE_PAD_UPRIGHT_SHAFT	ヒサアテタテシク	(1)
20		SM-9061203-SE	SCREW M6 L=12	ロツカクホルト M6 L=12	(1)
21		229-34202	KNEE_PAD_PLATE	ヒサアテイタ	(1)

NOTE (注記)

01...ACCESSORIE PARTS

付属品

13. AK DEVICE COMPONENTS

AK装置関係

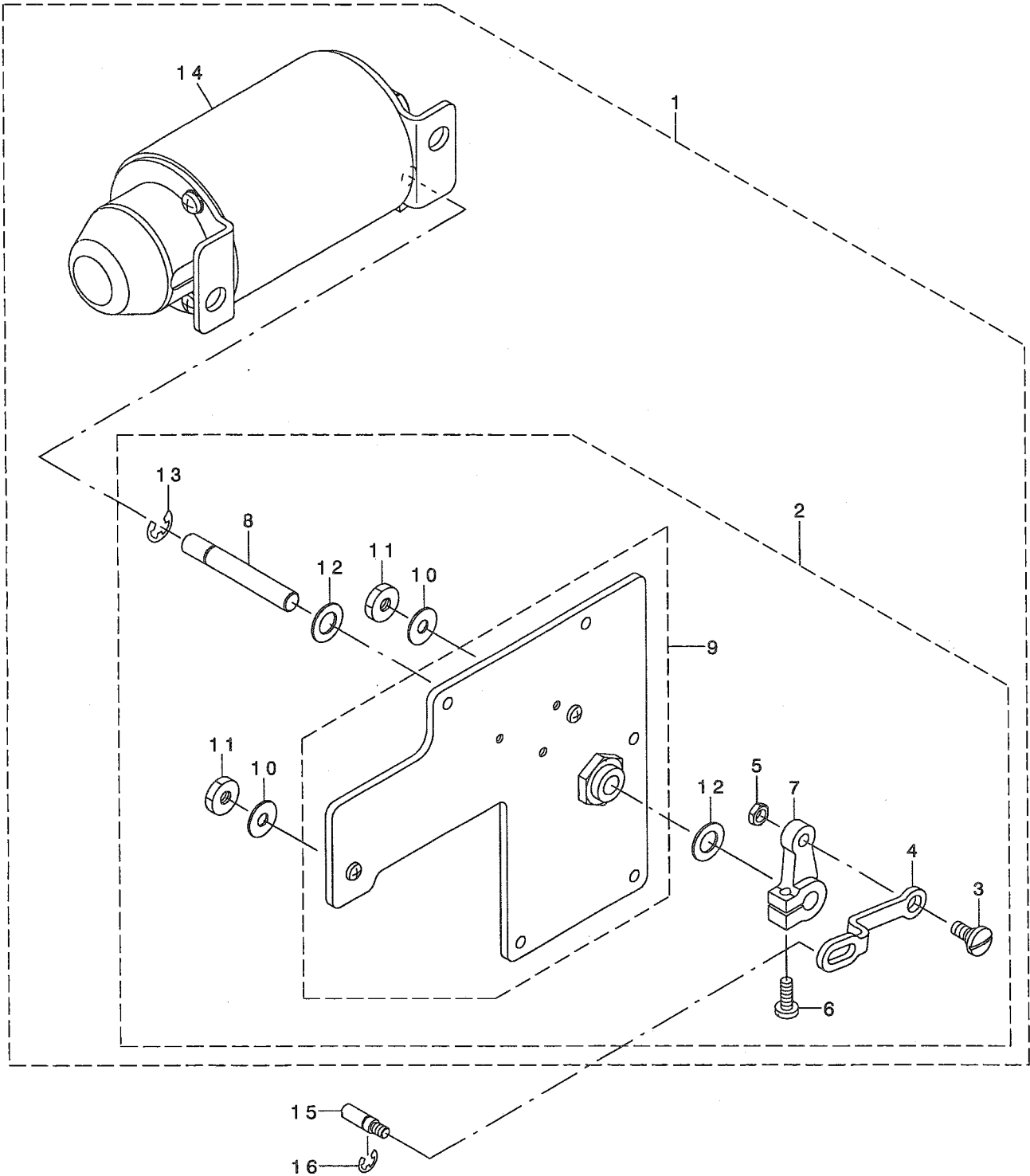

REF. NO	NOTE	PART NO.	DESCRIPTION	ヒソメイ	Qty
1		400-36221	ASSY_AK_DEVICE	AKソウチクミ	1
2		400-36222	COMP_REAR_PLATE	マト'イタクツコ'ウ	(1)
3		SD-0800352-SP	HINGE SCREW D= 8 H= 3.5	ダ'ソネジ' D=8 H=3.5	(1)
4		400-30962	SOLENOID_LINK	ソレノイト'リンク	(1)
5		NS-6150310-SP	NUT 15/64-28	ワッカクナツト 15/64-28	(1)
6		SS-7121410-TP	SCREW 3/16-28 L=14	マルヒラネジ' 3/16-28 L=14	(1)
7		GAK-33027000	SOLENOID ARM	ソレノイト'ウデ' B	(1)
8		229-91400	SOLENOID SHAFT	ソレノイト'シ'ク	(1)
9		400-36223	ASSY_REAR_PLATE	マト'イタクミ	(1)
10		WP-0621036-SP	WASHER	ヒラサ'カ'ネ	(2)
11		NS-6150440-SP	NUT 15/64-28	ワッカクナツト 15/64-28	(2)
12		WP-1021016-SD	WASHER	ヒラサ'カ'ネ 10.2X18X1	(2)
13		RE-0700000-KO	E-RING 7	Eカ'タメワ 7	(1)
14		GAK-A18300B0	AK SOLENOID ASM. , B	AKソレノイト' (クミ)B	(1)
15		400-30954	SHAFT_PIN	ヒサ'アケ'ヨコホ'ウビ'ソ	1
16		RE-0500000-KO	E-RING	Eカ'タメワ 5	1

14. THREAD STAND COMPONENTS

糸立装置関係

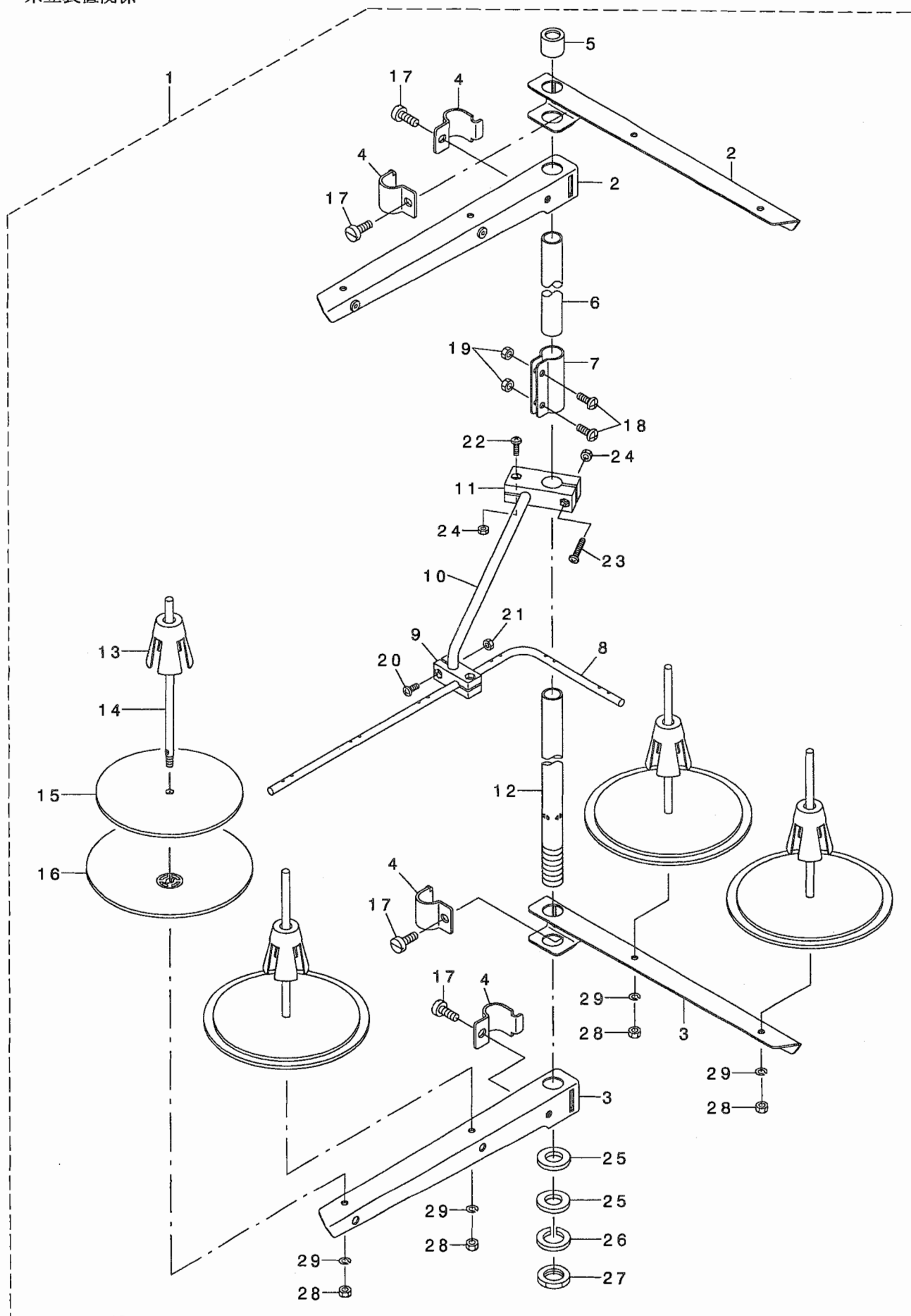

REF. NO	NOTE	PART NO.	DESCRIPTION	ヒソメイ	Qty
1		131-67556	THREAD STANDING DEVICE ASM.	イトテソウチ(クミ)	1
2		229-30556	SPOOL REST ARM ASM.	イトテウテ(クミ)	(2)
3		229-30507	SPOOL REST ARM	イトテウテ	(2)
4		229-30705	THREAD GUIDE ARM JOINT	イトテホ ウツメカナク	(4)
5		229-31406	THREAD STANDING ROD RUBBER CAP	イトテホ ウホコ コム	(1)
6		229-30408	THREAD STANDING ROD, UPPER	イトテホ ウ(ウエ)	(1)
7		229-31307	THREAD STANDING ROD JOINT	イトテホ ウツキテ	(1)
8		131-67903	THREAD STANDING THREAD GUIDE	イトテイトアンナイ	(1)
9		131-68000	THREAD STANDING GUIDE BASE	イトテイトアンナイ(シタ)タイ	(1)
10		131-68109	THREAD STANDING GUIDE ARM	イトテイトアンナイウテ	(1)
11		131-68208	THREAD STANDING GUIDE ARM BASE	イトテイトアンナイウテ タイ	(1)
12		229-30309	THREAD STANDING ROD, LOWER	イトテホ ウ(シタ)	(1)
13		229-31109	SPOOL RETAINER	イトマキフレトメ	(4)
14		229-31000	SPOOL PIN	イトマキウケホ ウ	(4)
15		229-30903	SPOOL REST CUSHION	イトマキウケサ ラクツシヨソ	(4)
16		229-30804	SPOOL REST	イトマキウケサ ラ	(4)
17		SM-6061610-SC	SCREW M6 L=16	ヒラコネジ M6 L=16	(4)
18		SM-4051405-SE	SCREW M5 L=14	ナハコネジ M5 L=14	(2)
19		NM-6050001-SE	NUT M5	ロツカクナツト M5	(2)
20		SM-4041001-SC	SCREW M4X0.7 L=10	ナハコネジ M4X0.7 L=10	(2)
21		NM-6040002-SE	NUT M4X0.7	ロツカクナツト M4X0.7 2ツ	(2)
22		SM-4041201-SC	SCREW M4 L=12	ナハコネジ M4 L=12	(1)
23		SM-4042001-SC	SCREW M4 X 20	ナハコネジ M4X0.7 L=20	(1)
24		NM-6040002-SE	NUT M4X0.7	ロツカクナツト M4X0.7 2ツ	(2)
25		WP-1612616-SE	WASHER 16X30X2.6	ヒラザカネ	(2)
26		WS-1643202-KR	SPRING WASHER	ハネサカネ 16.4X26.6X3.2	(1)
27		NM-6160511-SE	NUT M16X1.5	ロツカクナツト M16X1.5 1ツ	(1)
28		NM-6050001-SE	NUT M5	ロツカクナツト M5	(4)
29		WS-0510002-KN	SPRING WASHER	ハネサカネ 5.1X9.2X1.3	(4)

15. ACCESSORIE PARTS COMPONENTS

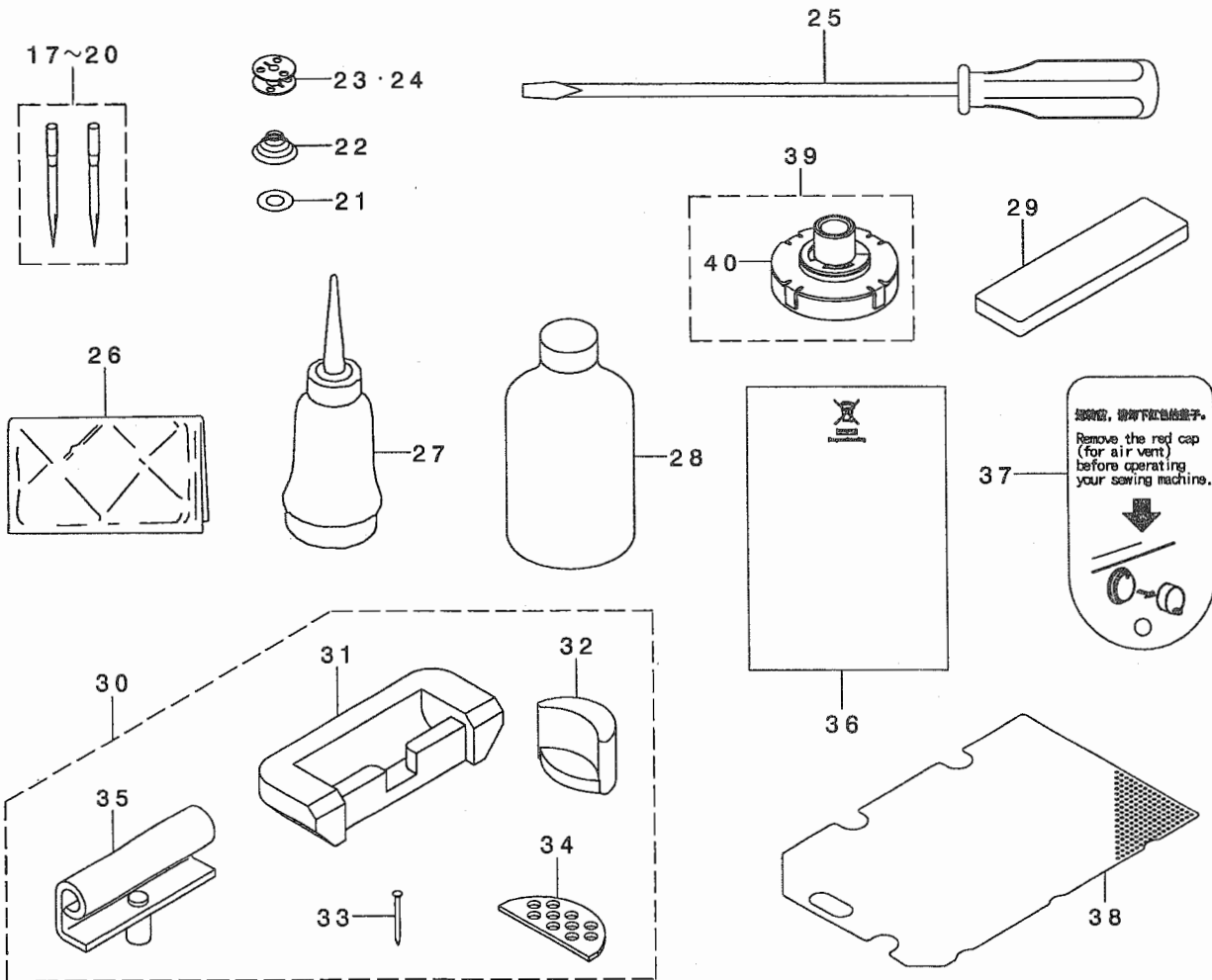
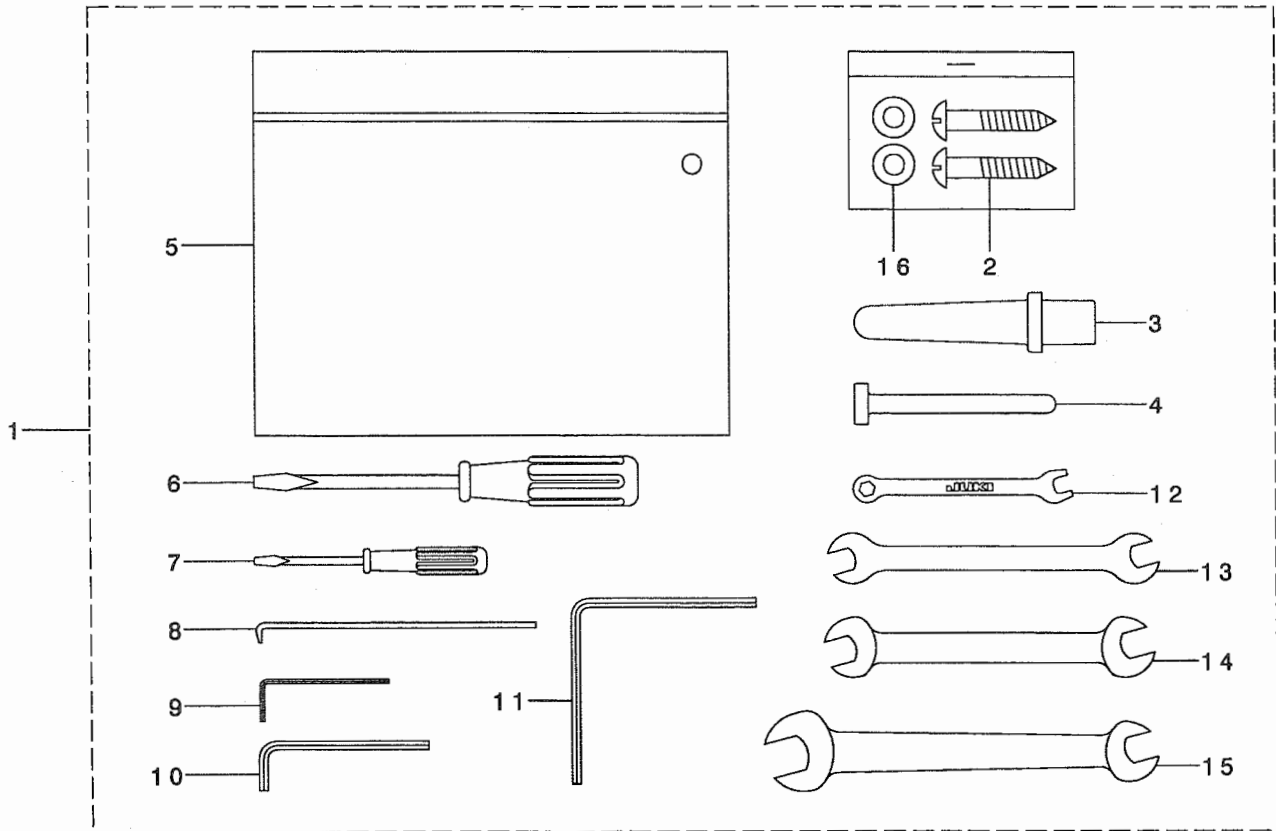

付属品関係



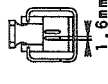
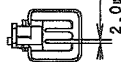
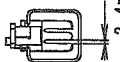

REF. NO	NOTE	PART NO.	DESCRIPTION	ヒンメイ	Qty
1		400-33439	ACCESSORIE BAG_ASM	フツ クヒンハ ッククミ	1
2		SK-3482501-SE	WOOD SCREW D=4.8 L=25	マルモクネツ D=4.8 L=25	(2)
3		229-31604	FRAME SUPPORT BAR	トウフ ササエホ ウ	(1)
4		236-39701	KNEE LIFTER PRESSER ROD	ヒサ アゲ オホホ ウ	(1)
5		229-32800	ACCESSORIE BAG	フツ クヒンハ ック	(1)
6		229-33105	SCREW DRIVER, MIDDLE	ト ライハ -(チユウ)	(1)
7		229-33204	SCREW DRIVER, SMALL	ト ライハ -(ショウ)	(1)
8		B9101-490-000	DRIVER	ト ライハ -	(1)
9		124-55507	HEXAGONAL WRENCH, 1.5	ロツカクレンチ(1.5)	(1)
10		124-55705	HEXAGONAL WRENCH, 2.5	ロツカクレンチ(2.5)	(1)
11		400-36707	HEXAGONAL WRENCH	ロツカクレンチ	(1)
12		131-60106	SPANNER (5X6)	スハ ナ(5X6)	(1)
13		260-34801	WRENCH (7X8)	リョウク チスハ ナ(ショウ) 7*8	(1)
14		262-33700	WRENCH (10X11)	リョウク チスハ ナ(ショウ) 10*11	(1)
15		260-34702	WRENCH (14X11)	リョウク チスハ ナ(タ イ) 14*11	(1)
16		WP-0501016-SC	WASHER 5X10.5X1	ヒラサ カ ネ 5X10.5X1	(2)
17☆	04	MDP-500B1002	NEEDLE DPX5 #10-2	ハリ DPX5 #10-2	1
18☆	03	MDP-500B1402	NEEDLE DPX5#14-2	DPX5#14-2	2
19☆	05	MDP-500B2102	DPX5#21-2	ハリDPX5#21-2	1
20☆	06	MDP-500B0902	NEEDLE DPX5#9-2	ハリDPX5#9-2	1
21☆	01	226-53802	SHEET	クウテンホ ウツシート	1
22☆	01	101-11508	SPRING	クテンホ -シハ ネ	1
23☆	01	102-10805	HARD ALUMITE BOBBIN	コウツツアルマイト ホ ビン	2
24☆	02	B9117-051-000	BOBBIN	ホ ビン	2
25		229-33006	SCREW DRIVER, LARGE	ト ライハ -(タ イ)	1
26		229-33303	VINYL COVER	トウフ ヒ ニールカバー	1
27		B9121-012-0A0	OILER ASM.	アブ ラサシ クミ	1
28☆	*	MML-007600CA	JUKI MACHINE OIL 7	シ ュキマツシヨイル7	1
29		400-35873	FILTER_B	フィルタ-B	1
30		229-26059	RUBBER HINGE ASM.	ラハ -ヒンジ (クミ)	1
31		229-26000	RUBBER CUSHION	ゴ ムヒンジ サ	(2)
32		229-26109	FRAME RUBBER CUSHION	トウフ ササエゴ ムサ	(2)
33		229-26208	NAIL	ゴ ムヒンジ サ ウチクキ	(8)
34		229-26505	WASHER	トウフ クツシヨンサ	(2)
35		229-26356	HINGE COMPL.	ヒンジ クツゴ ウ	(2)
36		CM-6001002-01	WEEE INFORMATION SHEET	WEEE インフォメーション シート	2
37		400-37488	SHEET	エア-ヌキキャップ チュウイシート	1
38		400-30768	OIL_FILTER	オイルフィルタ	1
39		400-36428	ASSY_FILTER_A	フィルタ-エークミ	1
40☆		400-36125	FILTER	フィルタ-	(1)
NOTE (注記)			01....FOR LH-3528-7	LH-3528-7用	
			02....FOR LH-3528	LH-3528用	
			03....TYPE S	S仕様	
			04....TYPE F	F仕様	
			05....TYPE G	G仕様	
			06....TYPE A	A仕様	

16. TABLE OF EXCHANGING GAUGE PARTS (1)(FOR LH-3528)

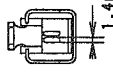
交換ゲージ部品一覧表 (1) (LH-3528用)

Needle gauge size 針 幅		Presser foot asm. 押 さ え(組)					Swivel guide Presser asm. スィフ・ルカ・イト 押さえ(組)	
Code コード					(Tip-divided) (移動式先割れ) 	(Tip-divided) (移動式先割れ) 	(Lower feed) (下送り) 	
	inch	mm	Part No.	Part No.	Part No.	Part No.	Part No.	Part No.
A	3/32	2.4	226-37557					
B	1/8	3.2	226-37656	400-35896		103-91852	226-27251	226-47051
C	5/32	4.0	226-37755	400-35897				
D	3/16	4.8	226-37854	226-40353	228-16557	103-92058	226-27350	226-47150
E	7/32	5.6		226-40452			*01 226-27459	*01 226-47259
F	1/4	6.4	226-38050	226-40551	228-16755	103-92256	226-27558	226-47358
G	9/32	7.1	226-38258	226-40759			226-27657	226-47457
H	5/16	7.9	226-38357	226-40858	228-16953		226-27756	226-47556
K	3/8	9.5	226-38456	226-40957	228-17050			
W	7/16	11.1		226-41054	400-33941			
L	1/2	12.7	226-38753	226-41252		103-92751		
M	5/8	15.9		226-41351				
N	3/4	19.1	226-38951	226-41450	400-33947	103-93056		
P	7/8	22.2	226-39157	226-41658		228-44450		
Q	1	25.4	226-39256	226-41757		228-44559		
R	1-1/8	28.6	226-39355	226-41856	400-33953			
S	1-1/4	31.8	226-39454	226-41955				
T	1-3/8	34.9		226-42052				
U	1-1/2	38.1		226-42151				
Stitch spec. 縫 仕 様	A		★					
	F						★	★(テーフ ^o 付け)
	S			★				
	G				★			
	下送り						★	

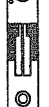
*01.....Special order parts
特別注文部品

Needle gauge size 針 幅		Throat plate 針 板	Throat plate (with Taping) 針 板(テーフ ^o 付)	Throat plate (Lower feed) 針 板(下送り)
Code コード				
	inch	mm	Part No.	Part No.
A	3/32	2.4	226-25008	
B	1/8	3.2	226-25107	226-28002
C	5/32	4.0	226-25206	228-45200
D	3/16	4.8	226-25305	226-28200
E	7/32	5.6	226-25404	228-45408
F	1/4	6.4	226-25503	226-28309
G	9/32	7.1	226-25602	228-45606
H	5/16	7.9	226-25701	226-28408
K	3/8	9.5	226-25800	226-28507
W	7/16	11.1	226-25909	226-28606
L	1/2	12.7	226-26006	
M	5/8	15.9	226-26105	228-46109
N	3/4	19.1	226-26204	228-46307
P	7/8	22.2	226-26303	228-46406
Q	1	25.4	226-26402	228-46505
R	1-1/8	28.6	226-26501	
S	1-1/4	31.8	226-26600	
T	1-3/8	34.9	226-26709	
U	1-1/2	38.1	226-26808	
Stitch spec. 縫 仕 様	A		Spec. common	
	F		Spec. common	
	S		仕 様 共 通	
	G		仕 様 共 通	
	下送り			★

17. TABLE OF EXCHANGING GAUGE PARTS (2)(FOR LH-3528)



交換ゲージ部品一覧表 (2) (LH-3528用)



Needle gauge size 針 幅			Feed Dog 送り歯				
Code コード	inch mm		(Option) (オプション)	(Option) (オプション)	(Option) (オプション)	(Option) (オプション)	(Option) (オプション)
	Part No.		Part No.		Part No.		Part No.
A	3/32	2.4	400-33714				
B	1/8	3.2	400-33715	400-35883	400-33563	400-33563	
C	5/32	4.0	400-33716			400-25784	
D	3/16	4.8	400-33718	400-35884	400-33564	400-25785	B1613-512-00H 400-25801
E	7/32	5.6		400-35885	400-33565	400-25786	
F	1/4	6.4	400-33720	400-35886	400-33566	400-25787	B1613-512-F0H 400-25803
G	9/32	7.1	400-33722	400-35887	400-33567	400-25788	
H	5/16	7.9	400-33723	400-35888	400-33568	400-25789	B1613-512-H0H 400-25805
K	3/8	9.5	400-33724			400-25790	B1613-512-K0H 400-25806
W	7/16	11.1				400-25791	B1613-512-W0H 400-25807
L	1/2	12.7	400-33727			400-25792	
M	5/8	15.9				400-25793	
N	3/4	19.1	400-33729			400-25794	B1613-512-N0H 400-25810
P	7/8	22.2	400-33731			400-25795	
Q	1	25.4	400-33732			400-25796	
R	1-1/8	28.6	400-33733			400-25797	B1613-512-R0H 400-25813
S	1-1/4	31.8	400-33734			400-25798	
T	1-3/8	34.9				400-25799	
U	1-1/2	38.1				400-25800	
Stitch spec. 縫仕様	A		★				
	F			★	★		
	S					★	
	G						★
	下送り						

Needle gauge size 針 幅			Feed Dog (Lower feed) 送り歯(下送り)		Needle clamp ass. 針留組	Sliding plate asm.(Left) 滑り板(左)組	Sliding plate asm.(Right) 滑り板(右)組	Sliding plate asm. (Front) 滑り板(前)組	
Code コード	inch mm		Part No.	Part No.	Part No.	Part No.	Part No.	Part No.	Part No.
	A	3/32	2.4			400-35875			
B	1/8	3.2	232-05107		400-26027				
C	5/32	4.0			400-26029				
D	3/16	4.8	232-05305		400-26031				
E	7/32	5.6			400-26033				
F	1/4	6.4	232-05503		400-26035	226-01058	226-00555		
G	9/32	7.1			400-26037				
H	5/16	7.9			400-26039				
K	3/8	9.5			400-26041				
W	7/16	11.1			400-26043				
L	1/2	12.7		228-48105	400-26045			400-34931	232-06709
M	5/8	15.9			400-26047	226-01157	226-00654		
N	3/4	19.1		228-48303	400-26049				
P	7/8	22.2		228-48402	400-26051				
Q	1	25.4		228-48501	400-26053	226-01256	226-00753		
R	1-1/8	28.6			400-26055				
S	1-1/4	31.8			400-26057				
T	1-3/8	34.9			400-26059	226-01355	226-00852		
U	1-1/2	38.1			400-26061				
Stitch spec. 縫仕様	A								
	F				Spec. common	Spec. common	Spec. common	Spec. common	★(テープ付)
	S								
	G				仕様共通	仕様共通	仕様共通	仕様共通	
	下送り			★	★				

18. TABLE OF EXCHANGING GAUGE PARTS (FOR LH-3528-7)

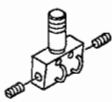
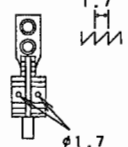
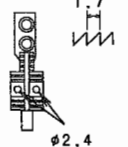
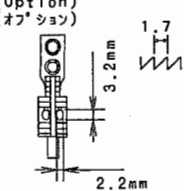
交換ゲージ部品一覧表 (LH-3528-7用)

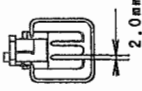
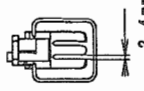
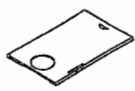
Needle gauge size 針 幅		Throat plate 針 板	Needle clamp asm. 針 留 組	Feed dog 送 り 歯		
Code コ-ト'						
	inch	mm	Part No.	Part No.	Part No.	Part No.
B	1/8	3.2	400-35881	400-26027	400-35890	
C	5/32	4.0	400-25485	400-26029	400-25817	
D	3/16	4.8	400-25490	400-26031	400-25818	400-35891 400-25831
E	7/32	5.6	400-25491	400-26033	400-25819	
F	1/4	6.4	400-25492	400-26035	400-26715	400-35892 400-25833
G	9/32	7.1	400-25493	400-26037	400-25820	
H	5/16	7.9	400-25494	400-26039	400-25821	
K	3/8	9.5	400-25495	400-26041	400-25822	
W	7/16	11.1				
L	1/2	12.7	400-25498	400-26045	400-25824	400-35894 51 400-25838
M	5/8	15.9	400-25499	400-26047	400-25825	
N	3/4	19.1	400-25500	400-26049	400-25826	
P	7/8	22.2	400-25502	400-26051	400-25827	
Q	1	25.4	400-25503	400-26053	400-25828	
R	1-1/8	28.6	400-25504	400-26055	400-25829	
S	1-1/4	31.8	400-25505	400-26057	400-25830	
Stitch spec. 縫 仕 様	S	Spec. common	Spec. common	★		
	G	仕 様 共 通	仕 様 共 通		★	★

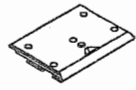
Needle gauge size 針 幅		Presser foot asm. 押 さ え (組)		Sliding plate asm. (Left) 滑 り 板 (左) 組	Sliding plate asm. (Right) 滑 り 板 (右) 組	Sliding plate asm. (Front) 滑 り 板 (前) 組
Code コ-ト'						
	inch	mm	Part No.	Part No.	Part No.	Part No.
B	1/8	3.2	400-35896			
C	5/32	4.0	400-35897			
D	3/16	4.8	226-40353			
E	7/32	5.6	226-40452			
F	1/4	6.4	226-40551			
G	9/32	7.1	226-40759	400-25247	400-25235	
H	5/16	7.9	226-40858			
K	3/8	9.5	226-40957			
W	7/16	11.1				400-31358
L	1/2	12.7	226-41252			
M	5/8	15.9	226-41351	400-25248	400-25236	
N	3/4	19.1	226-41450			
P	7/8	22.2	226-41658			
Q	1	25.4	226-41757	400-25249	400-25239	
R	1-1/8	28.6	226-41856			
S	1-1/4	31.8	226-41955	400-25250	400-25240	
Stitch spec. 縫 仕 様	S	★		Spec. common	Spec. common	Spec. common
	G		★	仕 様 共 通	仕 様 共 通	仕 様 共 通

19. LIST FOR INFORMATION OF CHANGE

変更情報リスト

As to the place changed, refer to the corresponding Rev.No.
 When previous parts (Obsoleted part) and new parts (Added parts) are not interchangeable with each other:
 In this case, even obsoleted parts (D.) can be ordered with the obsoleted part number, so select the parts with changed dates and place your orders.

変更箇所は、該当Rev.No.版をご参照ください。
 部品の互換性がない変更の場合は、削除された品番でも、ご注文できます。

40036442

No.1446-01 Rev.No.

*A: Added parts 追加部品 / D: Obsoleted parts 削除部品 / E: Erratum 訂正

* Rev. No.	Page 頁	Ref. No.	Parts No. 品番	* Rev. No.	Page 頁	Ref. No.	Parts No. 品番
D 00	2	63	SM-4040655-SP	A 01	2	63	SM-6040552-TP
				A 01	2	77	400-22407
				A 01	2	78	TA-0750704-R0
D 00	4	11	400-26998	A 01	4	11	400-29964
D 00	4	23	400-39182	A 01	4	23	400-32993
D 00	4	29	SM-8061550-TP	A 01	4	29	SM-8061612-TP
				A 01	4	79	TA-0500301-R0
				A 01	4	80	TA-0370301-R0
D 00	8	12	400-28490	A 01	8	12	400-42121
D 00	8	17	101-11201	A 01	8	17	226-14002
D 00	8	18	101-09809	A 01	8	18	226-14101
D 00	8	19	101-12506	A 01	8	19	226-14200
D 00	8	24	SM-4050655-SP	A 01	8	24	SM-4050855-SP
D 00	8	32	400-28492	A 01	8	32	B1820-563-000
D 00	8	33	400-28493	A 01	8	33	B1821-051-000
D 00	8	54	NM-6040000-SN	A 01	8	54	NS-6110420-SP
				A 01	8	67	400-40549
				A 01	8	68	400-40550
D 00	10	33	B1636-581-AA0	A 01	10	33	B1636-581-B00
D 00	10	60	SM-7050850-TP	A 01	10	60	SM-4051055-SP
D 00	10	78	WP-1651616-SD	A 01	10	78	WP-1751616-SD
				A 01	10	83	SM-6051850-TP
				A 01	10	84	229-52501
				A 01	10	85	SM-4050655-SP
				A 01	10	86	226-56003
				A 01	10	87	400-40924
				A 01	10	88	400-29257
				A 01	10	89	NM-6050001-SP
				A 01	10	90	WP-0520656-SA
D 00	14	9	RC-0650811-KP	A 01	14	9	400-10434
D 00	14	62	400-35264				
D 00	14	63	SM-4050655-SP				
D 00	14	64	WP-0520656-SA				
				A 01	14	62	SM-6052502-TP
				A 01	14	63	B3538-112-000
				A 01	14	64	SM-6040552-TP

NUMERICAL INDEX OF PARTS

索引

PART NO 品番	PAGE 頁	REF NO	PART NO 品番	PAGE 頁	REF NO	PART NO 品番	PAGE 頁	REF NO	PART NO 品番	PAGE 頁	REF NO
B1104-051-000	2	26	MDP-500B0902	28	20	SM-1030501-SN	14	41	SM-7050850-TP	10	48
B1118-512-000-A	6	40	MDP-500B1002	28	17	SM-1030501-SN	14	44	SM-8030312-TP	14	54
B1438-512-A00	4	52	MDP-500B1400	4	64	SM-1040750-TP	2	21	SM-8031612-TP	10	77
B1438-512-B00	4	53	MDP-500B1402	28	18	SM-1040750-TP	2	25	SM-8040402-TP	2	23
B1438-512-C00	4	54	MDP-500B2102	28	19	SM-1040750-TP	2	30	SM-8040412-TP	10	23
B1501-581-000	12	37	MML-007600CA	28	28	SM-2040750-TP	2	32	SM-8040412-TP	10	76
B1505-227-T00-A	12	36	M4002-110-000	4	26	SM-2040750-TP	10	53	SM-8040502-TP	21	39
B1521-555-000	12	2				SM-4031501-SC	16	8	SM-8040612-TP	10	38
B1636-581-B00	10	33	NM-6030001-SC	14	7	SM-4040601-SC	14	5	SM-8050412-TP	2	19
B1653-470-000	10	24	NM-6030001-SN	10	79	SM-4040655-SP	10	31	SM-8050412-TP	10	11
B1820-563-000	8	32	NM-6040001-SP	10	69	SM-4041001-SC	26	20	SM-8050412-TP	10	46
B1821-051-000	8	33	NM-6040002-SE	26	21	SM-4041055-SP	2	48	SM-8050612-TP	6	48
B1822-051-000	8	31	NM-6040002-SE	26	24	SM-4041055-SP	4	58	SM-8050612-TP	12	18
B1823-051-000	8	55	NM-6050001-SE	26	19	SM-4041201-SC	26	22	SM-8051002-TP	8	39
B1834-512-000	20	72	NM-6050001-SE	26	28	SM-4041655-SP	16	7	SM-8060550-TP	8	75
B3111-126-000	6	33	NM-6050001-SP	10	28	SM-4042001-SC	26	23	SM-8060552-TP	4	14
B3115-552-000	6	32	NM-6050001-SP	10	89	SM-4050655-SP	8	53	SM-8060552-TP	10	81
B3118-552-A00	6	45	NM-6050001-SP	16	37	SM-4050655-SP	10	85	SM-8060612-TP	4	9
B3118-552-F00	6	46	NM-6060001-CP	10	54	SM-4050655-SP	20	57	SM-8060612-TP	4	15
B3120-125-000	6	34	NM-6060001-SE	22	5	SM-4050655-SP	20	77	SM-8060612-TP	4	20
B3126-012-000	6	35	NM-6060003-SC	14	18	SM-4050855-SP	2	1	SM-8060612-TP	4	38
B3132-552-000	6	38	NM-6160511-SE	26	27	SM-4050855-SP	2	4	SM-8060612-TP	4	40
B3214-047-000	6	8	NS-6080210-SP	6	50	SM-4050855-SP	2	6	SM-8060612-TP	8	5
B3517-009-000	20	43	NS-6090310-SP	18	22	SM-4050855-SP	6	57	SM-8060612-TP	8	62
B3525-357-000	20	58	NS-6110310-SP	6	51	SM-4050855-SP	8	24	SM-8060612-TP	8	69
B3534-012-000	20	59	NS-6110310-SP	18	9	SM-4050855-SP	14	14	SM-8060612-TP	8	70
B3538-112-000	14	63	NS-6110310-SP	20	48	SM-4050855-SP	14	26	SM-8060612-TP	8	72
B9101-490-000	28	8	NS-6110420-SP	8	54	SM-4050855-SP	16	14	SM-8060612-TP	10	44
B9117-051-000	8	56	NS-6150310-SP	24	5	SM-4050855-SP	18	21	SM-8060612-TP	14	61
B9117-051-000	28	24	NS-6150440-SP	24	11	SM-4051055-SP	10	60	SM-8060812-TP	4	45
B9121-012-OA0	28	27	NS-6620310-SP	12	27	SM-4051255-SP	2	67	SM-8061550-TP	4	22
						SM-4051255-SP	10	27	SM-8061612-TP	4	29
CM-1001000-01	2	54	PS-0300122-KH	10	30	SM-4051255-SP	20	19	SM-8063012-TR	22	6
CM-2001001-01	2	69	PT-0502700-SO	4	51	SM-4051405-SE	26	18	SM-8081652-TP	4	17
CM-2001001-02	2	68				SM-4051601-SC	21	4	SM-9040603-SC	2	28
CM-2002002-01	2	52	RC-0650811-KP	14	3	SM-4055001-SF	20	79	SM-9050850-SP	14	21
CM-2002002-02	2	53	RE-0320000-KO	18	27	SM-4062001-SC	21	3	SM-9050850-SP	14	31
CM-3002000-01	2	70	RE-0400000-KO	16	23	SM-6030672-TP	10	34	SM-9051003-SD	14	57
CM-3002001-A1	2	49	RE-0500000-KO	12	10	SM-6040552-TP	2	63	SM-9061203-SE	22	20
CM-3011001-01	2	56	RE-0500000-KO	12	13	SM-6040552-TP	12	44	SM-9061853-SR	22	14
CM-3011001-02	2	55	RE-0500000-KO	24	16	SM-6040552-TP	14	64	SQ-0000401-MZ	20	60
CM-6001002-01	28	36	RE-0600000-KO	14	11	SM-6040602-TP	12	7	SQ-2050453-MZ	8	16
CQ-2020000-00	4	3	RE-0700000-KO	24	13	SM-6040602-TP	20	40	SQ-2050453-MZ	8	25
CQ-2020000-00	4	5	RE-0900000-KO	10	13	SM-6040650-TP	20	47	SQ-2060451-MZ	8	60
CQ-2020000-00	8	37	RE-1000000-KO	22	13	SM-6040655-TP	2	31	SS-1090520-TP	14	47
CQ-2020000-00	8	38	RO-0371801-00	12	3	SM-6041602-TP	20	71	SS-3090520-SP	18	29
CQ-2520000-00	4	7	RO-0371801-00	20	62	SM-6050650-TP	10	71	SS-4110515-SP	21	15
CQ-2520000-00	4	59	RO-0442401-00	8	27	SM-6050650-TP	16	35	SS-4110515-SP	21	33
CQ-3030000-00	4	12	RO-0481901-00	20	16	SM-6050800-SP	10	1	SS-4110615-SP	16	3
			RO-0481901-00	20	24	SM-6050800-SP	10	21	SS-4110715-SP	12	29
D2112-555-B00	2	3	RO-0801502-00	2	66	SM-6050800-SP	10	61	SS-4111215-SP	12	31
D2112-555-B00	20	63	RO-0982401-00	20	5	SM-6050802-TP	18	26	SS-5091020-SP	6	49
D2464-555-B00	16	22	RO-1952401-00	20	42	SM-6051000-SP	10	14	SS-6090520-SP	6	53
D3128-555-D00	6	36	RO-2192001-00	20	6	SM-6051002-TP	4	68	SS-6090580-TP	14	48
D3129-555-D00	6	37	RO-2573501-00	8	73	SM-6051002-TP	20	9	SS-6090810-TP	8	35
D3163-555-B00-A	12	30				SM-6051202-TP	14	34	SS-6111210-SP	4	30
D3164-555-B00	12	45	SB-1200002-00	4	46	SM-6051202-TP	14	37	SS-6121860-SP	10	19
			SB-1200025-00	4	37	SM-6051400-SP	10	41	SS-6153040-SP	8	42
EA-9500B01-00	14	59	SD-0470316-TP	6	47	SM-6051600-SP	4	75	SS-7081310-SP	21	24
EA-9500B01-00	20	45	SD-0490261-SP	21	23	SM-6051600-SP	10	6	SS-7081310-SP	21	40
EA-9502B02-00	2	62	SD-0490261-SP	21	37	SM-6051600-SP	10	52	SS-7090910-TP	12	43
			SD-0500301-SP	18	23	SM-6051600-SP	10	74	SS-7110350-SP	21	19
GAK-A18300B0	24	14	SD-0640357-TP	12	14	SM-6051850-TP	10	83	SS-7110710-SP	16	15
GAK-33027000	24	7	SD-0650321-TP	18	4	SM-6052502-TP	14	62	SS-7110840-SP	21	29
			SD-0700328-TP	16	34	SM-6060800-SP	2	12	SS-7121410-TP	24	6
HA-0005900-00	18	14	SD-0700346-TP	14	65	SM-6060800-SP	12	39	SS-8090670-SP	6	19
HA-0019000-00	16	10	SD-0800352-SP	24	3	SM-6061002-TP	16	24	SS-8090670-SP	6	29
HK-0346101-40	16	38	SD-0900356-TP	12	15	SM-6061150-TP	10	29	SS-8090670-SP	6	39
HK-0346400-OB	16	13	SD-0900426-TP	10	4	SM-6061200-SP	14	28	SS-8110410-TP	2	76
HK-0346400-OB	16	19	SD-0900706-TP	10	55	SM-6061610-SC	26	17	SS-8110510-SP	21	25
HK-0346400-OB	18	20	SK-3412000-SC	21	12	SM-6061802-TP	4	71	SS-9111010-SP	16	21
HW-2003900-00	18	15	SK-3482501-SE	28	2	SM-6062502-TP	8	50			
HW-5000700-00	16	9	SL-4030631-SC	18	3	SM-6063002-TP	16	29	TA-0290301-MO	8	29
HW-5000700-00	18	16	SL-4030641-SE	18	18	SM-6063502-TP	8	43	TA-0290301-MO	8	49
			SL-4051001-MZ	4	33	SM-6750690-TP	10	25	TA-0370301-RO	4	80
MDP-170B2100	4	65	SL-6040892-TN	20	4	SM-6850400-SP	14	53	TA-0490601-RO	4	42

NUMERICAL INDEX OF PARTS

索引

PART NO 品番	PAGE 頁	REF NO	PART NO 品番	PAGE 頁	REF NO	PART NO 品番	PAGE 頁	REF NO	PART NO 品番	PAGE 頁	REF NO
TA-0500301-RO	4	79	131-68000	26	9	229-30556	26	2	236-29306	20	33
TA-0750404-RO	4	1	131-68109	26	10	229-30705	26	4	236-29405	20	21
TA-0750704-RO	2	78	131-68208	26	11	229-30804	26	16	236-29405	20	27
TA-0800504-RO	2	9	133-19405	10	73	229-30903	26	15	236-29405	20	34
TA-0950806-RO	2	58	137-65607	20	64	229-31000	26	14	236-29900	2	65
TA-1050504-RO	2	71				229-31109	26	13	236-30007	20	11
TA-1050504-RO	2	72	225-29473	6	9	229-31307	26	7	236-30007	20	31
TA-1250406-RO	2	10	226-00555	2	37	229-31406	26	5	236-30007	20	38
TA-1250406-RO	2	11	226-01058	2	33	229-31604	28	3	236-30007	20	50
TA-1250406-RO	2	73	226-03708	2	44	229-32107	22	4	236-30007	20	52
TA-1250705-RO	2	17	226-03708	20	73	229-32206	22	8	236-30007	20	53
TA-1470704-RO	2	57	226-05307	4	2	229-32404	22	11	236-30007	20	54
TA-1600406-RO	2	15	226-06800	4	66	229-32453	22	10	236-30007	20	65
TA-1650406-RO	2	59	226-10307	10	8	229-32800	28	5	236-30007	20	66
			226-13509	8	34	229-33006	28	25	236-30007	20	67
WP-0350516-SD	6	55	226-14002	8	17	229-33105	28	6	236-30007	20	68
WP-0371016-SD	8	36	226-14101	8	18	229-33204	28	7	236-30106	20	20
WP-0371016-SD	18	30	226-14200	8	19	229-33303	28	26	236-30106	20	28
WP-0430800-SD	2	50	226-19100	2	8	229-33600	21	11	236-30106	20	35
WP-0430800-SD	20	70	226-21056	21	28	229-33659	21	9	236-30106	20	75
WP-0450801-SD	4	31	226-21106	21	36	229-33758	21	10	236-30601	20	30
WP-0480856-SP	21	38	226-21155	21	27	229-34202	22	21	236-30601	20	37
WP-0501016-SC	21	13	226-22401	4	10	229-34251	22	15	236-30650	20	29
WP-0501016-SC	28	16	226-25503	2	35	229-34301	22	16	236-30650	20	36
WP-0501016-SD	16	16	226-40551	12	42	229-34400	22	17	236-39701	28	4
WP-0501016-SD	16	20	226-53802	8	58	229-34509	22	18	260-34702	28	15
WP-0520656-SA	10	90	226-53802	28	21	229-34608	22	19	260-34801	28	13
WP-0520656-SA	20	78	226-56003	10	86	229-34707	22	12	262-30409	20	69
WP-0531000-SD	14	22	226-56508	16	4	229-37965	4	32	262-33700	28	14
WP-0531000-SD	14	32	226-57100	18	17	229-44508	12	28			
WP-0531000-SD	18	35	226-57209	18	5	229-44904	12	26	400-00344	20	23
WP-0531000-SD	20	80	226-57308	18	8	229-45307	6	11	400-04171	4	16
WP-0531001-SC	21	6	226-57803	2	46	229-45307	6	24	400-06323	2	74
WP-0550800-SP	4	69	228-10907	4	8	229-45505	6	7	400-09196	18	6
WP-0550800-SP	20	10	228-11301	6	41	229-45703	6	6	400-09222	6	54
WP-0612056-SD	16	31	228-88507	8	74	229-52501	10	84	400-10434	14	9
WP-0621016-SD	8	44	229-01805	2	29	229-54200	16	5	400-11906	10	32
WP-0621016-SD	16	26	229-07604	12	34	229-54309	16	6	400-11926	10	68
WP-0621036-SP	24	10	229-07703	12	35	229-54408	16	11	400-11932	10	37
WP-0621046-SP	14	17	229-07802	12	1	229-54606	16	2	400-11934	10	36
WP-0641600-SC	21	7	229-08008	12	9	229-55504	18	2	400-11935	10	7
WP-1021016-SD	24	12	229-20201	12	19	229-55900	18	10	400-11939	10	43
WP-1612616-SE	26	25	229-20706	2	18	229-56007	18	11	400-11946	10	35
WP-1751616-SD	10	78	229-21209	6	12	229-56205	18	7	400-11947	8	76
WS-0510002-KN	26	29	229-21209	6	25	229-57104	18	13	400-12403	14	49
WS-0521010-KN	21	5	229-21407	6	14	229-57203	18	19	400-12404	14	58
WS-0610002-KP	16	30	229-21407	6	26	229-62005	6	28	400-12487	14	46
WS-0631510-KP	16	25	229-21506	6	15	229-91400	24	8	400-12488	14	45
WS-1643202-KR	26	26	229-21506	6	23	232-03201	6	42	400-12489	14	55
WT-0530002-KS	2	7	229-21605	6	16	232-03300	6	44	400-12492	14	39
			229-21605	6	27	232-04506	4	60	400-12495	14	50
101-09908	8	40	229-21704	6	17	232-04605	4	61	400-12496	14	56
101-11508	8	59	229-21803	6	18	232-04704	4	62	400-12497	14	38
101-11508	28	22	229-21803	6	22	232-06709	2	75	400-12503	14	35
101-12407	8	41	229-26000	28	31	235-33805	10	42	400-12504	14	29
101-12605	8	20	229-26059	28	30	235-33904	10	16	400-12505	14	19
101-12704	8	21	229-26109	28	32	235-34019	10	47	400-12505	14	30
101-19204	16	36	229-26208	28	33	235-34506	10	17	400-12506	14	20
101-26803	20	51	229-26356	28	35	235-40305	20	49	400-13061	8	6
101-61305	16	17	229-26505	28	34	235-42418	14	6	400-13316	14	60
101-62600	22	9	229-27354	21	14	236-01057	2	5	400-13362	10	64
102-08700	18	28	229-28105	21	22	236-01305	2	64	400-13509	20	15
102-09203	18	31	229-28303	21	21	236-09001	12	41	400-15669	14	24
102-09500	18	32	229-28303	21	35	236-09209	12	33	400-15699	6	56
102-09807	18	33	229-28402	21	20	236-09605	12	6	400-16748	8	26
102-09906	18	34	229-28402	21	34	236-18804	8	7	400-16749	20	39
102-10805	8	57	229-28501	21	26	236-26005	6	13	400-17033	14	51
102-10805	28	23	229-28808	21	18	236-26005	6	21	400-17353	14	1
110-40854	14	10	229-28808	21	32	236-26005	6	31	400-17361	14	13
113-05901	14	27	229-28907	21	16	236-26054	6	10	400-17362	14	25
124-55507	28	9	229-28907	21	30	236-26062	6	20	400-17394	14	2
124-55705	28	10	229-29004	21	17	236-27458	6	30	400-17399	14	8
131-02702	4	76	229-29004	21	31	236-28803	20	13	400-17400	14	12
131-60106	28	12	229-30309	26	12	236-28902	20	14	400-17401	14	15
131-67556	26	1	229-30408	26	6	236-29306	20	12	400-17402	14	16
131-67903	26	8	229-30507	26	3	236-29306	20	26	400-17403	14	23

N U M E R I C A L I N D E X O F P A R T S

索引

PART NO 品番	PAGE 頁	REF NO	PART NO 品番	PAGE 頁	REF NO	PART NO 品番	PAGE 頁	REF NO	PART NO 品番	PAGE 頁	REF NO
400-17624	4	27	400-28730	2	27	400-34675	2	42			
400-17625	4	28	400-28766	2	2	400-34840	6	52			
400-21883	14	40	400-28773	20	17	400-34853	22	3			
400-21898	14	43	400-28774	20	18	400-34926	20	2			
400-21899	14	42	400-28778	22	2	400-34931	2	40			
400-22407	2	77	400-28797	18	24	400-34969	8	10			
400-22427	6	5	400-28799	18	25	400-34970	8	47			
400-22449	20	25	400-28851	8	2	400-34971	8	11			
400-22450	20	32	400-28852	10	51	400-34972	8	48			
400-22589	8	22	400-28853	4	74	400-34974	12	32			
400-22590	8	23	400-28854	10	5	400-35151	12	11			
400-22678	4	6	400-28855	10	72	400-35180	2	51			
400-23568	4	55	400-28868	12	5	400-35181	12	16			
400-23569	4	56	400-29027	16	12	400-35264	20	76			
400-24093	4	4	400-29047	4	39	400-35277	16	33			
400-24436	4	18	400-29048	4	35	400-35278	16	32			
400-25191	22	7	400-29049	4	43	400-35298	12	21			
400-25235	2	38	400-29075	20	22	400-35298	12	23			
400-25247	2	34	400-29078	2	20	400-35394	12	4			
400-25316	10	65	400-29079	10	20	400-35704	10	50			
400-25329	4	50	400-29257	10	88	400-35828	12	22			
400-25492	2	36	400-29347	2	22	400-35873	28	29			
400-26035	4	63	400-29350	16	28	400-36125	28	40			
400-26394	4	49	400-29570	8	28	400-36167	20	8			
400-26395	4	48	400-29641	2	16	400-36221	24	1			
400-26482	4	72	400-29905	21	2	400-36222	24	2			
400-26673	10	12	400-29964	4	11	400-36223	24	9			
400-26811	2	60	400-30037	4	77	400-36333	20	61			
400-26920	4	47	400-30298	2	14	400-36359	14	4			
400-27099	4	25	400-30768	28	38	400-36360	16	18			
400-28031	4	78	400-30856	16	27	400-36428	28	39			
400-28116	4	36	400-30915	8	3	400-36433	10	18			
400-28117	4	19	400-30954	24	15	400-36446	14	36			
400-28245	2	13	400-30956	18	12	400-36679	10	56			
400-28250	6	4	400-30962	24	4	400-36682	8	14			
400-28264	12	8	400-31348	10	26	400-36683	8	15			
400-28268	12	17	400-31349	10	40	400-36690	2	61			
400-28269	12	40	400-31350	10	75	400-36707	28	11			
400-28271	8	1	400-31351	8	4	400-37488	28	37			
400-28274	10	57	400-31352	14	33	400-39604	20	46			
400-28275	10	58	400-31358	2	39	400-40549	8	67			
400-28276	10	59	400-31862	4	57	400-40550	8	68			
400-28277	10	49	400-31864	4	13	400-40809	20	74			
400-28279	10	39	400-32107	22	1	400-40924	10	87			
400-28280	10	63	400-32124	4	73	400-42086	20	81			
400-28281	10	62	400-32142	4	34	400-42121	8	12			
400-28284	10	3	400-32268	10	45						
400-28285	10	82	400-32269	10	10						
400-28286	10	9	400-32272	12	38						
400-28287	10	70	400-32293	10	22						
400-28291	10	66	400-32405	20	55						
400-28293	10	2	400-32406	20	56						
400-28294	10	67	400-32707	6	1						
400-28485	8	8	400-32708	6	2						
400-28486	8	45	400-32709	6	3						
400-28487	8	9	400-32804	20	44						
400-28488	8	46	400-32896	2	43						
400-28489	8	61	400-32987	4	21						
400-28491	8	13	400-32993	4	23						
400-28494	8	30	400-32994	4	24						
400-28495	8	51	400-33160	14	52						
400-28496	8	52	400-33408	16	1						
400-28545	12	12	400-33409	21	1						
400-28546	12	20	400-33434	12	24						
400-28555	2	41	400-33435	12	25						
400-28560	8	63	400-33437	18	1						
400-28561	8	64	400-33439	28	1						
400-28562	8	65	400-33667	4	44						
400-28563	8	66	400-33668	10	80						
400-28652	4	41	400-33669	4	70						
400-28656	8	71	400-33995	10	15						
400-28666	4	67	400-34053	2	47						
400-28689	20	1	400-34246	20	41						
400-28705	20	7	400-34267	21	8						
400-28706	2	45	400-34649	20	3						
400-28707	2	24	400-34660	6	43						

JUKI®

JUKI CORPORATION

MARKETING & SALES H.Q.
8-2-1, KOKURYO-CHO, CHOFU-SHI
TOKYO 182-8655, JAPAN
PHONE : (81)3-3480-2357 . 2358
FAX : (81)3-3430-4909 . 4914

Copyright © 2005 JUKI CORP.
本書の内容を無断で転載、複写すること
を禁止します。
All rights reserved throughout the world.

JUKI 株式会社

〒182-8655 東京都調布市国領町8-2-1
TEL. 03-3480-1111(代表)

営業本部
TEL. 03-3480-2357(ダイヤルイン)

お問い合わせ、ご相談は
To order or for further
information,
please contact :

※このパーツリストは商品改良のため予告なく変更する事があります。
* The description covered in this parts list is subject to change for improvement of the commodity without notice.
※このパーツリストは、2005年11月現在の商品仕様で編集したものです。
* This parts list is edited in accordance with the product specifications as of November 2005.